

UMASS/AMHERST



312066 0333 3280 3

LIBRARY

OF THE



MASSACHUSETTS  
AGRICULTURAL  
COLLEGE

NO. 67

1.

SOURCE

---

E

3







LIBRARY

UNIVERSITY OF  
MASSACHUSETTS  
AMHERST, MASS.

THE  
**British Bee Journal,**  
AND  
BEE-KEEPER'S ADVISER.

EDITED BY  
THE REV. HERBERT R. PEEL,  
LATE HON. SECRETARY OF THE BRITISH BEE-KEEPERS' ASSOCIATION.

VOLUME XII.

JANUARY-DECEMBER, 1884.

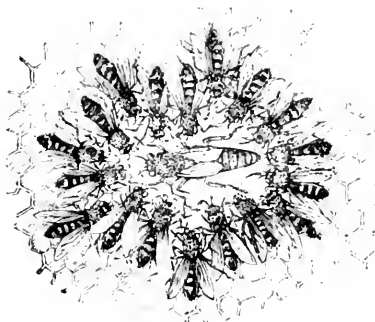

PUBLISHED BY JOHN HUCKLE, KINGS LANGLEY, HERTFORDSHIRE:  
AND BY  
KENT AND CO., 23 PATERNOSTER ROW, E.C.









# THE BRITISH BEE JOURNAL

Communications to the Editor to be addressed 'STRANGEWAYS' PRINTING OFFICE, Tower Street, St. Martin's Lane, w.c.'

[No. 137. VOL. XII.]

JANUARY 1, 1884.

[PUBLISHED FORTNIGHTLY.]

## Editorial, Notices, &c.

JANUARY.

THE past year has been a very anxious and arduous one for the British Bee-keepers' Association, but through the exertions and liberality of a small section of its members (we wish we could say by the united effort of the bee-keepers of Great Britain) the storm has been weathered, and the bark of the Association is now in smoother water. It is only right that the generosity of the President and Committee in advancing the sum of one hundred and fifty pounds (for which they have declined to accept any interest) should be publicly acknowledged, as by this means the Association has been saved from collapse and disintegration. Recognising the fact that its main object is to instruct the agricultural and other labouring classes of Great Britain in the most humane and profitable methods of bee-keeping, the Association has found that the simplest and most effective method of accomplishing this object is the establishment of County Associations affiliated with the Central in every County of England and Wales in which Bee-keeping is possible, and where the inhabitants take sufficient interest in this pursuit. It was never supposed when these County Associations were first started that ladies and gentlemen who had joined the Association from philanthropic motives would refuse to continue their very small subscription of five shillings to the Parent Association, because an Association had been started in their own county, and they had felt themselves called to belong to it. Such is, however, the experience of those whose uphill task it has been to manage the affairs of the British Bee-keepers' Association during the last few years. If the Association had died, it would not have died a natural death, but have been killed, like the eagle, by an arrow winged from its own feathers. Those who should have given the Central Association an extra amount of support, because it had been the means of conferring a benefit on their own County, have made that very benefit an excuse for deserting the Old Association, and in many cases, after having enjoyed its privileges for the space of a year without any acknowledgment. The loss upon the Bridge-water and Knightsbridge Shows last year was, no

doubt, a very considerable one, being over 150% ; but this loss was sustained under extraordinary circumstances, which are not likely to occur again. The desertion of our Members because they join County Associations is a far more serious loss, inasmuch as it is constantly recurring; and this must be checked and remedied by every means possible. The Central Association does not increase in members as it should do, because, though new members join us, old members are continually deserting us, on the flimsy excuse above mentioned. It is the punishment of the daughters of Danaus inflicted upon innocent mortals. We are trying to fill vessels from which the water is always running out.

We must turn from such frail, bending reeds as these *sheep* philanthropists to the true supporters of our Association, who have come forward to help it in the day of its adversity, and thank them heartily for the response which they have lately made to the appeal issued on behalf of the Show Deficiency Fund. Valuable as their aid has been in a pecuniary sense, almost doubly valuable is the encouragement which it has given to the President and Committee in continuing the task which has been assigned to them. To feel that they have the sympathy of the members of the Association, and to know that the time, trouble, and money which they have spent on the Association's behalf are acknowledged and appreciated, is worth very much to them. It is an assurance that their task has not been altogether a thankless one.

But to the members who have made no response to the Appeal Circular, and yet belong to the Association, we must make one further appeal, and beg them, if they are resolved to ignore the Deficiency Fund, to consider whether they cannot afford to *double their subscriptions* for the year 1884. There is a great deal before the Association. To say nothing of the Exhibition which is to be held at Shrewsbury in connexion with the Royal Agricultural Society, which is to open up North Wales to a sense of its shortcomings, we ought not to be satisfied unless the British Bee-keepers' Association finds a place in the International Health Exhibition at South Kensington. A display of unadulterated British honey, and of the means of its production or collection, continued during six months of next year, would give an interest in bee-keeping to thousands and thousands of visitors, and give them all some

idea of the work in which the British Bee-keepers' Association is engaged. What an advantage would such a display give to our manufacturers of hives and bee-keeping appliances! How many new editions of *Modern Bee-keeping* and our other publications would it necessitate! How many new Members might we hope to enlist!

Then there is on all sides an earnest expectation of another Bligh Competition, under improved rules, which is likely to attract a much larger number of competitors than those who entered for the first experiment. Nor must we forget that the supply of medals for the Annual Shows of the County Associations must be kept up, and that Bee Tents must be lent out for these occasions; that the Quarterly Conversaciones must be continued, and the papers then read printed and circulated among the members; that Experts are to be sent out with the Bee Tents throughout the length and breadth of England and Wales, and Judges supplied for the County Shows. This year also must advance, if not achieve, a solution of the Honey Market Question, and of the establishment of a Central Depot, perhaps in connexion with a Museum and Reading Room. And there is an even more important task looming in the future with regard to the Adulteration of Honey, and the prosecution of those who persist in attempting to palm off upon the British public some spurious article (glucose or other) bearing the name of honey, but of which it may be truly said—

'Plus alois quam mellis habet.'

With all this before us, no one can say that the Central Association will not have abundance of work upon its hands during the year 1884; and we hope that its members will be ready to afford it additional support, in view of the additional labour which it has undertaken in the last few years. This is the season at which we forget all that it has been hard to bear, and devote ourselves to good wishes and anticipations of blessings and happiness in the coming year. In offering our accustomed greetings to all readers of the *Journal*, we take the opportunity of reminding them that Christmas is a season in which the hearts of men are naturally enlarged, and are more accessible to appeals for help and assistance from those who need and deserve it. We think that the British Bee-keepers' Association has shown itself *deserving* of help at this particular stage of its history. That help is *needed*, must be obvious to all. We have many new Life Members, but we must remember that the greater number of these have hitherto been Annual Subscribers, and that these subscriptions, amounting to 10*l.* or more, have been lost to the Association, and its income diminished in proportion. If those who have as yet done nothing to help us will double their subscriptions for 1884, this loss will be remedied, as well as that entailed by desertions, and the Association will enter upon the new year with renewed confidence, more determined than ever to accomplish the task which it undertook ten years ago.

#### ASSOCIATION DEFICIENCY FUND.

The following is a list of new Life Memberships and of Donations to the Fund:—

J. N. Bower, Esq.; E. Bostock, Esq.; H. Bostock, Esq.; Duke of Buckingham and Chandos; A. H. Heath, Esq.; C. H. Hodgson, Esq.; Rev. F. G. Jenyns; Rev. W. E. Medlicott; T. Nottidge, Esq.; C. P. Ogilvie, Esq.; Col. Pearson; Col. E. Smyth; Mrs. Thos. Wain; Captain C. D. Campbell; Mrs. Meeking; J. Marten; C. E. Fletcher; Colonel C. T. Caldecott	£90	0	0
W. Cartmel	2	2	0
F. L. May	2	2	0
T. W. Cowan	2	0	0
Hon. and Rev. H. Bligh	1	1	0
Cray Valley Bee Farm	1	1	0
Col. Pictou-Turberville	1	0	0
Thomas F. Ward	1	0	0
J. Noble	1	0	0
Miss E. Preston	0	10	6
Rev. F. S. Selator	0	10	6
D. Stewart	0	10	6
Captain Bush	0	10	0
W. H. Phillips	0	10	0
Col. Merrick	0	10	0
Isaac Rodham	0	7	0
G. H. Gadd	0	5	0
J. C. Arber	0	5	0
Miss Octavia Peel	0	5	0
F. Leete	0	5	0
A. Rusbridge	0	5	0
W. H. Dunman	0	5	0
Miss Gayton	0	5	0
W. Soar	0	5	0
W. H. Williams	0	5	0
G. Drinkwater	0	5	0
W. Hollands	0	5	0
Rev. P. M. Fillent	0	5	0
S. J. Baldwin	0	5	0
Rev. H. R. Peel	5	0	0
G. Neighbour and Sons	5	0	0
W. Kirchner	0	10	6
G. H. Aubrey	0	10	6
C. Tite	0	10	6
S. Stutter	0	10	0
Rev. Norman Ogilvy	0	10	0
J. Walton	0	5	0
Rev. J. Evans	0	5	0
H. E. Roberts	0	5	0
Mrs. Goodhart	0	5	0
Rev. W. E. Burkitt	0	5	0
J. R. Truss	0	5	0
	£122	1	0

With the assistance of our friends who have not yet subscribed to the above Fund we hope in our next issue to have the satisfaction of announcing that the whole of the debt (150*l.*) has been cleared off.

#### APICULTURE IN 1883.

During the past twelve months apiculture has made marked progress. This is evidenced by the great increase in the number of those who have taken up bee-keeping either from the fascination connected with it as a pursuit, or from the profit arising from it as an occupation; by the formation of several new County Associations, and the prosperous condition of those which have been established; by the increased interest taken in bee literature; by the development of the business of the pur-

voyors of bee-appliances, and by the general spirit of inquiry which has been evoked respecting the management and the economy of the honey-bee.

During the past year the work of the British Bee-keepers' Association and that of the affiliated associations has been very arduous; but great and lasting results have followed their exertions. A large increase in the number of members has taken place, and the work of several Associations has been rendered more perfect by being enabled to employ experts for the examination of the hives of the members.

Let us endeavour to particularise some of the work of the Central Society.

**NEW MEMBERS.**—Nearly 100 new members have joined the Association during the past year. It is to be hoped that the example of those who have become Life Members during the last few weeks will stimulate others to do likewise.

**BRIDGEWATER SHOW.**—Though the Committee were unable to obtain a grant from the West of England Agricultural Society, it was deemed desirable, in the interests of bee-keeping, to hold an exhibition of hives, honey, &c., at Bridgewater while the Agricultural Show was in progress. Much good was effected to the bee-keeping cause by this Show, but financially the Parent Society suffered severely, having incurred a loss of upwards of 70*l*.

**KNIGHTSBRIDGE SHOW.** The Annual Show was held at Knightsbridge in the Duke of Wellington's Riding School, the South Kensington Horticultural Gardens being occupied by the Fisheries Exhibition. This was undoubtedly the most successful Show that has been held by the Association. It is, however, much to be regretted that an exhibition, so desirable from a bee-keeping point of view, should have proved so disastrous as a financial speculation. For special reasons the exhibition was held much earlier in the season than usual, and it was much feared that there would be but a small display of honey. However, these fears were not realised, for the show of honey was exceedingly good. The sales effected amounted to nearly 200*l*., being 50*l*. in excess of any previous year. In the honey department, it was gratifying to find that a cottager, one of the class that the Association seeks more especially to benefit, far outdistanced all other competitors both as regards the prizes of honey and sales effected: he received upwards of 20*l*. from these two sources. Though there has been so considerable a loss on the Bridgewater and the Knightsbridge Shows, it has produced a kindly feeling towards the Parent Association, and there has arisen a spontaneity of feeling among bee-keepers that no ill results should happen to it or retard or impede the progress of the great work it has in hand. Up to the present time upwards of 120*l*. has been subscribed towards the liquidation of the Deficiency Fund.

**THE YORK SHOW.** As in former years, the department of the Royal Agricultural Society Show was a great success, and showed a decided advance on those which preceded it. The interest taken in the various bee-appliances, manipulations, and

lectures, was very great. Many persons travelled long distances to learn all they could about bees, and remained in the bee-tent nearly the whole day. The sale of bee-literature at the Show at York was also most encouraging.

**COUNTY ASSOCIATIONS.**—Three new County Associations have been established during the year. The number of affiliated Associations is now thirty-four. It is to be hoped that Associations may be speedily formed in the remaining counties of England and Wales that are not represented, and that those in which they have been established may continue to increase in numbers, and be able to provide experts, bee-tents, and other auxiliary adjuncts. Lecturers have been sent free of cost to Northants, Bucks, Somerset, Carmarthen, Brecon, Bedfordshire, Staffordshire, and Hunts.

**BEE LITERATURE.**—The fourth edition (the 24th thousand) of *Modern Bee-keeping*, was issued in the month of July; and already a considerable portion of the edition has been disposed of. The Association have also compiled a pamphlet on the management of 'Skeps,' which has met with a large and ready sale.

**EXAMINATION OF CANDIDATES FOR CERTIFICATES OF COMPETENCE IN BEE-CULTURE.**—The candidates at the Knights-bridge Exhibition amounted to ten in number, but only seven presented themselves for examination. This number was not so great as in the previous year; which may be accounted for by the subjects being more extensive and difficult. It was gratifying to find among the candidates one clergyman and several schoolmasters.

**HONEY FAIR AT GRANTHAM.** This fair, which was established in 1867 by the Lincolnshire B. K. A. under the auspices of Mr. R. R. Godfrey, was a great success this year. Above 5000 lbs. of honey were staged, and almost all of it was sold. The example shown by the Lincolnshire, and proved by that Association to be successful, should be adopted by every county possessing a Bee-keepers' Association.

**HIGH COMPETITION.**—One of the chief features of the past year has been the experiment which has been entitled 'the High Competition,' a competition which had its origin in the desire of the Hon. and Rev. H. Bligh that there should be some authentic information as to the cost and profit of bee-keeping, and that there might be some comparison between the various systems now in use. The value of the results has been very beneficial, and will prove of great service to intending bee-keepers. But as the competition was very limited, there has been a general expression of opinion that there should be a repetition of the experiment, and that it should be conducted on a broader basis and with amended rules.

**CONVERSAZIONI.**—Two conversazioni have been held during the year; at the first, the Rev. H. R. Peck read a paper on 'Who is the *bona fide* Cottager?' and at the second Mr. Otto Hehner delivered a lecture on the 'Chemistry of the Hive;' these were followed by very animated discussions.

At the Knightsbridge Show, Mr. Cheshire delivered a very interesting lecture on 'Bees as

Hybridizers and Fruit-producers; or the Dependence of Orchard Crops upon Bees.

**BRITISH BEE JOURNAL.**—The fortnightly issue of the *Journal* since May has met with great acceptance. Its circulation amongst County Associations, clubs, &c., is constantly increasing. The number of readers now probably amounts to 10,000. One correspondent writes: 'It will be encouraging to know that six *Journals* are taken in this parish, the population being only 560.' All those interested in the future of bee-keeping should seek to increase the circulation of the *Journal*, and we venture to solicit a renewal of the support of our readers for this new volume.

**HONEY AND WAX.**—We are much indebted to E. H. Bellairs, Esq., of Christchurch, for the trouble he has taken in furnishing our readers with the monthly value of the honey imported into the United Kingdom. We find that in the first eleven months of the year 1883, the value of honey was, from January to November, £32,616; being a monthly average of about £3000. The following tabular statement shows the amount of wax imported, and its value for the year 1882, with the names of the countries whence it was exported:—

	Cwts.	£
Germany ... ..	11,090	30,015
Portugal ... ..	4,243	24,064
Japan ... ..	7,337	16,910
United States ... ..	4,213	16,626
British East Indies ... ..	1,025	6,758
British West Indies ... ..	1,194	7,378
Other countries... ..	5,736	25,175
	35,528	126,926

From the preceding figures it would appear that nearly £160,000 per annum is expended in honey and wax; the bare mention of this fact ought to energize the bee-keepers in the United Kingdom, so that so large an amount of money should not be spent for those articles which it is possible for them to raise in their own land.

**THE HONEY SEASON.**—In the various shows throughout England, there has been a good display of honey. In some counties the produce has been fairly good; but from others—Cornwall for example—the reports have been very disheartening. In Scotland the yield has been very small; in Ireland under the average.

**INDIA.**—The attention of bee-keepers has, during the year, been directed to India, and the possibilities of the cultivators of the soil in that large country taking a greater interest in the promotion of bee-culture. Various interesting reports have been made at the instance of the Agricultural Department of the Government of India; and though the Government have declined to give any direct aid to bee-keeping, yet the information respecting the bees of India which has been educed will not fail to stimulate many to take a greater interest in bee-keeping.

We should not omit to mention in this review of the year, the admirable lecture given by Mr. H. Jenkins, on 'Some of the duties of a Farmer's Wife,' the object of which was to stimulate the wives and daughters of farmers to undertake bee-

keeping with a view to increase the income of the family.

We have thus taken a cursory glance at the principal events of bee-keeping of the year 1883; and we hope that with renewed zest, and increased energy and interest, bee-keepers may proceed with their labours during the coming year, and that these labours may be crowned with great success.—G. H., *Ealing*.

#### USEFUL HINTS.

**STORES.**—The weather during December has not been altogether unfavourable to bees. The temperature has not been so high as to cause much consumption of stores, while there have been sufficient opportunities for cleansing flights. Still, there may be some stocks which, in the probable event of a long frost, may find themselves within measurable distance of starvation. Therefore, our hints for December still hold good. Those stocks which appear active on days when all others are quiet should be specially attended to, as this may be taken as a probable sign of approaching famine, and a forlorn hope of foraging.

**DAMPNESS.**—Remove all causes of this deadly enemy to bees. Many hives are sent out, in which the body rests on the floor-board. This is a fruitful source of dampness; the wet draws under, spreads over the floor-board, and causes any dead bees or chippings of comb, or other rubbish, to become mouldy, and the whole hive damp and unhealthy. The best remedy is to screw fillets to the edges of the hive body, and if these are smeared with white lead before fixing, a good water-tight joint is formed. The hive sides in every well-made hive should be outside the floor-board.

**ENTRANCES.**—See that these are not in danger of being choked with dead bees. Search with a bent wire, and withdraw all dead bees and rubbish within reach.

**EXAMINATIONS.**—After examining a stock, be very careful to replace the quilt to avoid any draught. It is a good plan to pass a warm flat-iron over the undermost layer to re-seal the propolis.

**TOM-TITS.**—These birds are troublesome enemies. They tap at the entrances until a bee appears to see what is the matter, when she is instantly snapped up. The remedy is to put a piece of wire netting over the front of the hive, so that Tom cannot get to the alighting board.

**HIVES AND APPLIANCES.**—Now is the time to order these, with the prospect of being better served than in the height of the season. An order for bee appliances in January is like the quality of mercy, 'Tis twice blessed; it blesses him that gives, and him that takes.' Look over all spare tackle, paint, repair, and put in order.

**COMBS.**—Look over your stock of combs removed from hives when reducing for winter. Those containing stores will be useful to give to needy stocks. Before doing so, however, let the comb be warmed to the temperature of the hive. To introduce a mass of sealed honey without warming is like putting a block of ice into the hive. If there is

any trace of moth in the spare combs, cut out the trails and submit the combs to the fumes of burning sulphur in a box. Melt down all useless combs. Clarify the wax, and send it to be made into foundation, now, while you can get it done without delay.

**SKERS.**—The remarks above as to clearing entrances and prevention of dampness, apply to skeps as well as bar-frame hives; the roofs of skeps should throw the wet quite clear of the floor-boards.

### BLIGH COMPETITION.

May I be allowed to write a few words in answer to Mr. Hewitt's criticism on the competition to which the bee world has kindly attached my name. I note with pleasure the high compliment which he pays to the scheme generally, and trust that it may prove, as he puts it, a very good thing for the advancement of bee-keeping.

With regard to the rules, I think I may say on behalf of the B. B. Committee, who framed them, that they were the best which suggested themselves at the outset of a novel experiment; but as one of the judges, I may add that we certainly found them faulty. If a fresh competition is decided upon, the judges would advise that the rules should be amended.

Mr. Hewitt's suggestion that the time spent in the apiary at each visit should be recorded, seems to be a very good one, but I do not quite agree with him as to the advisability of making a charge for the time occupied by the competitor in his apiary. Our theory is, that every cottager and his wife between them have some leisure, some time in which to avoid the dullness which befell 'Jack,' who had 'all work and no play.' We accept it as an established fact that every cottager who has a comfortable home has some leisure (playtime we may call it) which he gives to his garden, his living pets, some handicraft or book on the winter's evening, a gossip and pipe with his neighbours, or a walk abroad in summer. His wife, whose time is generally at her own disposal, probably has more. I think all bee-keepers will agree that we could not find our cottager a more interesting and pleasure-giving recreation than bee-keeping. This is what we offer him in return for the time which he is willing to devote to bees. But then we go on further to show him that he can enjoy this pleasure free of cost, that it is not necessary for him to lay out a great deal of money as the squire at the hall does on his pets, his poultry and pigeons, and bees too, which may not appear to give him much return. A small capital only is necessary, and he may expect to have it soon returned to him, and may further expect his bees to pay his rent, and provide, perhaps, some other comforts also. Surely he would not set a price on the leisure time devoted to an interesting pastime which should produce such a result as this.

Rule 6 certainly was improperly worded, and we must ask pardon of those competitors who were misled, and thus, perhaps, kept back from a higher place in the prize list. Our real object was, I believe,

to bar the introduction into the apiary, whether by a system of credit or otherwise, of anything more than the 2*l.* capital would cover. Profits, however, passed to capital account I, for my part, always intended to allow, and still think that it would be unwise in a business competition not to allow the extension of the business by capitalising a portion of the profits.

In estimating the value of the honey produced it will probably be found best to have a fixed price for all, so much per pound for comb-honey and so much for extracted. In the table of comparative results of the past competition, no attempt was made by the judges to do more than register the number of pounds produced.

We should gladly have published a record of the failures of the unsuccessful candidates, but none volunteered to produce their diaries. The Rules required all competitors to produce them, but as soon as they retired from the competition no further pressure could be used.

In conclusion, let me state my belief that neither the Committee nor the judges are at all impatient of such friendly criticism as is contained in Mr. Hewitt's letter, but rather invite it, and trust that the wisdom of many experienced bee-keepers expressed in letters to the *Bee Journal* may help towards the framing of much more perfect rules for the next competition.—HENRY BUGH, *Hampton Hill*.

P.S. It is very desirable, if the next competition is to commence in May 1884, that those who wish to promote it should announce the donations which they intend to make towards the prize fund, as, owing to the deficiency upon the two shows held in the year 1883, the Committee of the B. B. K. A. may not feel justified in embarking upon such a competition unless the prize fund is fully guaranteed.

## BEE-KEEPERS AT HOME.

NO. IV.—THE REV. GEORGE RAYNOR, AT HAZEL-LEIGH RECTORY, MALDEN, ESSEX.

The subject of our present sketch was born on the 2nd of August, 1819, at Cropwell Butler, in the county of Nottingham, the eldest son of John Raynor, Esq., of Cropwell, and Ganthorpe, in the same county; sprung from a family possessed of considerable landed estates in various parts of that county, and one of whose members was High Sheriff in 1660, and a staunch Royalist, who proclaimed the Restoration of Charles II. in the ancient borough of Nottingham in that year. On the mother's side his descent was from the Innocent family, also possessed of landed property at Cropwell at that time, and of the same stock as the noted Dean of St. Paul's, the master of the Hospital St. Cross, Winchester, and the founder of the 'Free Schole and Chauntry in Barkhamptstoble,' in the year 1541.

Left an orphan at the early age of five, during a long minority Mr. Raynor's interests suffered considerably. In consequence of a delicate con-

stitution, his education was conducted privately; and it was not until the year 1845 that he finally selected the Church as his profession; and in the autumn of that year entered into residence at Clare College, Cambridge. Previous to this event, although engaged in country pursuits generally, he had not become a bee-keeper to any extent, though always taking interest in the cottage apiaries; and once in his boyhood having secured a vagrant swarm which took possession of a chimney in the paternal abode, by placing a skep on the top and driving the bees in by means of smoke from below.

It was during his University course that his tutor, the late Rev. W. Williamson—who was second Wrangler of his year, and took also a high classical degree—had occasion to deliver a course of lectures upon the writings of Virgil in general, and the Georgics in particular. This most interesting course closed with the fourth Georgic, when beautifully wrought honey-comb was introduced into the lecture-room, and that abstruse problem, proving the economy of space in the use by the bees of the hexagonal cell, was thoroughly explained and worked out. From this time Mr. Raynor became an enthusiast on the subject of apiculture; and although for some years no opportunity occurred of indulging his taste, he never afterwards lost the interest which had been evoked in this all-absorbing pursuit. At that early period he well remembers the beautiful supers of honey-comb, both in glass and straw, displayed in the shops of several of the University purveyors, and his country walks around Cambridge were often directed to the producers of these. After proceeding to the usual degree, Mr. Raynor was ordained in June, 1849, by Dr. Murray, Bishop of Rochester, to the curacy of Hemel Hempstead, in that diocese; and, after his marriage in the following year, having obtained an appointment in the diocese of Newcastle, Australia, sailed from England in November of the same year.

Having previously made the acquaintance of Bishop Abraham, who left England about the same time for New Zealand, he learned that the well-known apiarian, the Rev. W. Cotton, who, three years previously, had accompanied Bishop Selwyn as private chaplain, had taken out some colonies of English bees to that dependency of the British crown. This fact, together with an assurance that there was no scarcity of the domesticated honey-bee in the Australian colonies, induced him to forego his original intention of carrying out several stocks. On his arrival at Morpeth, N. S. W., the episcopal seat, he soon discovered that his bishop, Dr. Tyrrell, was already a possessor of some half-dozen hives, which, however, were left entirely in the hands of the gardener, and, as we usually find to be the case with the episcopal bees in the old country, brought their owner little profit. This neglected apiary was soon put into shape, a system of supering adopted, sloping hives placed upright, and under cover, and henceforth the Bishop's bees supplied their master's table with many a luscious comb of honey.

The arduous duties of a colonial clergyman—for the office of private chaplain, the mastership of the model school, with the sole charge of Morpeth and two other parishes, fell to Mr. Raynor's share of work—allowed but little time for the pursuit of apiculture. The missionary voyage of Bishop Tyrrell, in company with Bishop Selwyn, to the South Sea Islands, about this time, together with the gold discoveries, and the consequent depletion of the male population of his three parishes, added so enormously to his parochial duties that his health entirely broke down, and eventually necessitated his return to England.

Of the capabilities of New South Wales, Victoria, and South Australia, as a honey-producing country, Mr. Raynor speaks in glowing terms. Its orange groves, its extensive 'bush,' literally covered with magnificent creepers, its myriads of square miles of gum-trees (eucalyptus), forests, mangroves, and numerous other nectar-producing plants and trees, should render it a most extensive honey-exporting country. The bush, in those early times, around the settlements, was well stocked with bees, and from the hollow gum-trees the settler obtained sufficient honey for his own wants.

The climate, together with the receptacles used as hives, conducted to over-swarming. The skeps, imported, of the usual English cottage type, were by far too small for a climate where frost and snow are unknown, and where the country teems with nectar. On the issuing of a swarm, a tea-chest, or other half-froten box, full of chinks,—in fact, any thing which comes to hand, is thought good enough for living the swarm, and is at once set down on the spot, bereft of covering or shade. What wonder that the bees, driven out by the intense heat—at times 120° in the shade—take their departure for the woods!

With our modern system of expanding, or twin-hives, double-walled, and roof protected; with our sectional, and other supers,—in one word, indeed, with all our modern scientific apicultural appliances, what may not be achieved in such a climate?

Here it was, while located in the pretty rural parsonage of Morpeth, covered with its adolichus and westeria, and surrounded by its six-foot scarlet hedge of perennial geranium, that Mr. Raynor obtained his first Australian swarm, vagrant and towering aloft, brought to his feet, apparently, by the 'jingling of the cymbals of Mother Cybele.'

(To be continued.)

#### RUDDIMENTS OF BEE-KEEPING, INTENDED FOR BEGINNERS.

It has been pointed out that much of the contents of the *Journal*, however useful and interesting to existing bee-keepers, can be of little use to beginners, for the simple reason that they require something more elementary. *Modern Bee-keeping*, and similar books, it is true, tell them of the best and most modern methods of management; but to apply the knowledge thus given at proper times and in the best way is a task which all do



not find easy. We therefore propose, from time to time to give under the heading of

#### RECIDIVENTS OF BEE-KEEPING,

a series of short, simple articles, in which the beginner will find woven together the information he stands in need of. Now that the *Journal* is circulated amongst so many cottagers and others anxious to adopt a more enlightened and humane system of managing their bees, we hope that these articles may be specially of service to them.

At the present moment, any one wishing to commence bee-keeping, or wishing to adopt moveable comb-hives, must begin to make preparations for starting off in the spring. If he has no bees as yet, now is the time to try and get hold of bees which would otherwise be killed by their owners, and by making up from them a strong stock, and carefully feeding them, he will find in the spring that with but small outlay he has got the bees necessary to commence with. We suppose either that you know of some one willing to let you drive his bees and take them home with you, and that you have already in your garden some stocks in skeps. The honey harvest is rapidly drawing to a close, and the bees will soon have gathered all the honey obtainable this season. The moment this time arrives, drive the bees in the manner described in *Modern Bee-keeping*, and having united together a sufficient number to make a really strong stock, you must feed them carefully and with judgment, until you are satisfied that they have sufficient food for the winter. If you are afraid of being stung, by all means protect your face with a gauze veil and your hands with woollen gloves. It is easy to make yourself quite safe from stings. We do not, however, recommend gloves, as they are apt to make you clumsy, and the bees dislike the gloves far more than the naked hand. Unless squeezed, they usually will not sting your hand. Make sure, in case you do not wear gloves, that the bees cannot get up your sleeve. Before commencing to drive, get all in readiness: an empty skep, two pieces of wool with a nail in each end to keep the empty hive in position, a skewer, some smoke, and, if you are going to unite, some syrup scented with peppermint. After blowing enough smoke into the hive to thoroughly frighten the bees, allow them sufficient time to fill their sacks with honey, after which they are in a condition for being driven. You must hinge the empty hive on to the full one already turned upside down, sufficient smoke being used to make the bees think of themselves instead of what you are doing. But be careful not to use too much smoke, because should the bees become stupid and inactive, you will find great difficulty in driving them. And now the drumming must begin. You must have taken care to make the hinge in such a position that it comes on one of the edges of the full hive towards which the combs run. This gives a free passage between the combs for the bees to run up into the hive above. You must take care not to hit the sides of the hive so hard that you break the combs, or else you may crush many of your bees, as well as damage the combs. The object of your drumming the hive is to make the combs shake. Hit it as low down as you can, and not harder than required. Once you have the bees in the empty hive, remove and carefully cover the full one, and then proceed to drive any other stocks you may require.

Uniting the bees so as to form a strong stock is the next step. It will be unwise for a beginner to attempt to start driven bees off in a moveable comb-hive at this time of year without a good adviser close at hand. Far better winter them in a skep and then establish them or their swarm next spring. If you have a skep with clean combs in good condition, you might use this for your bees' winter quarters. It will be a great help to the bees to save them the labour of building comb. But be

careful not to give them comb tainted in any way, and be sure thoroughly to air the hive before using it. Now take, say, three lots of driven bees, scent them with scented syrup, throw them boldly all together on a sheet or piece of newspaper, and place the hive you are going to use near by, taking care to slightly raise the edge nearest to the bees to enable them more easily to enter. They will soon do this peaceably, but should you see signs of fighting, or they do not seem inclined to go in the right direction, a little smoke will be of use to keep them peaceable and guide them.

You must now feed them from a hole in the top of your skep with syrup, made carefully according to the receipt in *Modern Bee-keeping*. Be careful not to burn it when on the fire, and do not let it thicken by boiling so as to become thick like treacle. For autumn feeding a good proportion is 5 lbs. of sugar to 1 quart of water. If the bees have to make their comb, you must be very careful not to give the syrup in such quantities as to overweight and break down the tender young combs; otherwise they can be fed pretty liberally. — F. S. SCLATER.

#### AMONGST THE SWISS BEE-KEEPERS.—

##### No. IV.

On my arrival in Montreux, taking an especial interest in bee-keeping, I made inquiries to find out if there were any bee-keepers in the neighbourhood and if amongst these there were any progressive bee-keepers using moveable comb-hives. The landlord of the hotel, whom I found very intelligent, told me there were several, but he only knew of one who had the improved hives and offered to go with me and introduce me to him. This was a chance not to be thrown away, so I availed myself of his offer, and one fine afternoon we started off to Grandchamp, where I was introduced to M. J. von Siebenthal. The conversation immediately commenced about bees, and I soon found that I was in the presence of one who was thoroughly versed in the theory of bee-keeping at my rate. Any doubt as to his practical ability was quickly dispelled when he invited me to see his hives. He said this place was not very good for bees except in the spring, so he only kept some half-dozen hives here to amuse himself with, his principal apiary being some miles distant in the valley of the Rhone at St. Triphon. The hives, although few in number, were, however, immensely strong in bees, Camidan being the sort kept here. On asking if M. de Siebenthal had any difficulty to prevent them from swarming, he told me that he kept these for swarming, but could prevent them doing so in a great measure by giving them plenty of room for brooding purposes. The hives used are the Layens, and are large boxes with twenty frames, the inside dimensions being 20½ inches long by 12½ inches wide, and 16½ inches deep. Could such large hives be filled? This question was soon answered by M. de Siebenthal proceeding quietly to remove the quilt without using any smoke, nor had any of us any protection, but the bees behaved remarkably well and sustained their character for gentleness, and allowed us to handle and examine the combs with impunity. The hive was perfectly crammed with bees, and about sixteen of the twenty combs contained brood. Several of the other hives were also examined and were found equally strong. The neighbourhood, although very lovely as far as regards scenery, being on the borders of the Lac Lemán, close to the celebrated Castle of Chillon, with sloping vine-clad hills surmounted by precipitous crags, is a bad one for bees. Vineyards on the slopes capable of cultivation and woody precipices rising almost from the water's edge do not furnish good pasturage, so the bees have to rise a great height before they can reach suitable honey plants, and amongst these Alpine flowers they revel. There are a few fruit trees and flower-gardens, but these are only available in the spring, after

which time the bees get very little. The hives, however, can be transported, and only a few miles journey will take them into the fertile pastures of the Rhone Valley, where three and four crops of hay are obtained, these pastures being crowded with splendid honey-yielding plants, which we consider valuable enough to grow in our gardens at home, here only food for beasts. Our inspection of the hives completed, M. de Siebenthal invited me to see his apiary at St. Triphon.

Selecting a charming day I took the train from Montreux up the Valley of the Rhone, which at Villeneuve, the first station in the valley, is very wide and uninteresting, being a flat alluvial plain formed by the mud brought down by the river for ages. It is, however, well drained, and cultivated. Vines are still cultivated on the slopes of the hills, but the plain is full of rich honey-producing plants and mellilot clover growing wild in every possible place. The train carries us past Yverne, a small village standing in the centre of vineyards and producing a wine of some reputation, on to Aigle, noted for its black marble quarries. All along the line from here to St. Triphon grow acacias, said to be good honey-yielding plants. A walk of about a quarter of an hour through well-cultivated fields, consisting of clover and esparcet, brings us to M. de Siebenthal's apiary. Here we find eighteen hives of the Layens pattern well filled with bees. Six of these hives are in the open air against a wall, and there not being a passage behind them, the operations had to be performed from the front rather to the annoyance of bees and the discomfort of the operators. But what does a bee-keeper care for stings so long as he is at his favourite pursuit? So, regardless of stings, we proceeded to examine the hives. We found the bees were collecting vigorously, and the glistening honey in the open cells delighted my host. There was plenty of brood in all stages, and the queens were mostly young and vigorous. The other hives were kept in a loft, to which we had to climb by a ladder. Here were kept empty hives and all the requisites of an apiary, including a smoker which was filled with rotten wood and tobacco, lighted, and then we proceeded to examine some of the other hives. Some of these were swarms and were on five to six frames, but all were working as well as they should do, and were making beautiful straight combs. These are started on whole sheets of foundation kept in its place by three wires embedded into it.

M. de Siebenthal considers it advantageous to cultivate crops that are of service to bees, and has here got a plot of mustard which was just coming into seed and had yielded its honey in its season. Esparcet and lucerne were both in full bloom and were covered with bees. The bees kept here are Carniolans and the common black bees and a cross between the two. M. de Siebenthal considers the cross an improvement on the common bees; but they are certainly not as amiable as the Carniolans. From here his brother, M. P. de Siebenthal, who is a bee-keeper and a hive-manufacturer at Aigle, accompanied us for a walk across the fields of a couple of miles, to the apiary of M. Sumi at Grand Pré.

M. Sumi is a German Swiss from the Canton of Berne, and has a proclivity for the hives of his countrymen. There were fifty-five hives, mostly containing Carniolan bees, each hive having from eleven to fourteen frames. These were arranged in pavilions of twelve to sixteen, each having a ridged roof, the hives opening at the back. Some of these hives were opened and examined, all were strong and evidently had been well cared for. M. Sumi, although engaged in farming, does not consider bee-keeping as unworthy of attention, and bestows on his bees the same careful attention that he does to his other farm stock. He has one hive on the Layens principle, but this is a twin hive and contains forty frames. He acknowledges that hives opening from the top have an advantage over the others, and is so well satisfied with this plan that he intends increasing the

number of such hives. Surrounding his hives he has planted borage, on which the bees were very busy, and considers this one of the best honey plants. We then went to his extracting house and saw his extractor, which had recently been used in extracting honey from some of the combs. After this a homely repast under the trees was partaken of. Here milk and honey, both produced on the farm, with good bread and butter, was food good enough for a king, and fortified us for the next journey.

During our conversation I mentioned that I intended to call and see M. Bertrand's apiary at Nyon; whereupon my host told me that M. Bertrand was at that moment at his country chalet up in the mountains at Grion; and that, as we were only a few hours' journey from there, it was a pity to leave the neighbourhood without calling upon him. The distance being beyond a walk, the question was how to get there; and this was soon solved by M. Sumi insisting on taking a holiday and driving us all up to Grion.

A beautiful young horse was soon harnessed to a 'char,' in which we four seated ourselves, and to the merry tune of the bells on the horse's bridle we jogged along across the fields. The fields about here are not separated by hedges as with us, the only boundary marks of the various properties being stones about six inches square, and standing about six inches out of the ground. To remove one of these stones would be in reality 'to remove one's neighbour's landmark,' and would subject you to a heavy penalty.

This truly rural drive before very long brought us to the main road leading to Bex. The road along the foot of the mountains is rather flat, and passing La Gryonne, which is an unwholesome stream charged with sulphur and impregnated with salt, we arrive at the picturesque and favourite village of Bex, remarkable for its salt-mines and works, and as the resting-place of Charpentier the naturalist, who is buried in the pretty little cemetery, his tombstone being simply a boulder. The scenery at this spot is enchanting, in front to the right the snow-capped Dent du Midi, on the left the Dent de Morcles, their bases nearly touching and forming the Gorge de St. Maurice, through which the Rhone rushes angrily at being restrained within such a narrow channel.

At about the centre of the village, we stopped to examine the apiary of M. Borel, who has sixteen Layens hives all well filled. M. Borel not being at home, we proceeded to the end of the village and inspected the apiary of M. P. de Siebenthal, who has here twelve hives on the same principle. We found the bees bringing in honey in large quantities, some of the large frames being two-thirds sealed over. There was one large hive capable of taking three or four colonies of twenty frames each. It contained three colonies, and M. de Siebenthal's idea was to have them merely separated by division-boards, so that they could be joined at any time should they lose queens, and he thought it would be an advantage in wintering to bring the frames close together. The bees were the common black bees of the country, and signified their disapproval of our inspection by a free use of their stings.

Taking our seats in the char, we left Bex and commenced the ascent to Grion, which is about two and a half hours' drive from the former place.

An excellent though narrow carriage-road leads from Bex to Grion for about a mile by the River Avençon; the road here leaves the stream and begins to ascend to the left by numerous zig-zags, partly through beautifully shaded woods of fir, beech, and walnut. A little higher fertile pastures are passed, and all along the road I noticed chestnut-trees, lime-trees, sycamores, and other honey-yielding trees. Fruit-trees of all sorts are also cultivated amongst the pastures, and there was evidence on all sides of its being a land flowing with milk and honey.

As we rose higher and higher, first one mountain-peak, then another, came in view, and M. Sumi pointed out some almost inaccessible crags that he had surmounted in search of chamois, for he, in addition to being an enthusiastic bee-keeper and farmer, was a hardy mountaineer and chamois-hunter.

The scenery of this pass is extremely interesting, above us the liablers with its mountain slip, and below us in a valley surrounded on three sides by mountains, the little village of Freulères. I should have liked to have spent more time in admiring the scenery, but we had to press on, and in due time reached Grion. Here we soon found M. Bertrand's chalet, and I need hardly say that we were most courteously received and heartily welcomed.

There is a sort of freemasonry amongst bee-keepers; and although we had up to this time only read of each other, we were very soon on friendly terms and engrossed in bee talk.

M. Bertrand took us to see his bees, but told us that they were not doing very well, because his man in whose charge they were left during the greater part of the season wished, as he thought, to economise, and last season neglected to purchase sugar to feed them; the consequence being that a large number had died, and those that had survived had not sufficiently recovered to store up a large quantity of provisions. Here was a row, however, of about forty hives of the Dadant and Layens type, two or three of which were examined. I was asked to cut out and taste some of the honey, which I did, and found it of a peculiar smell and flavour. In fact, the same smell was noticed when the hives were opened, and M. Bertrand told me it was because the bees collected the honey from a flower called *Astrantia major*, which is very plentiful in the pastures in the mountains. M. Bertrand stated that he had noticed the peculiar flavour, but did not know whence it was derived, so therefore he watched his bees and found that they flew straight out of the hive in a direct line to the other side of the valley, so he determined to find out what took them there; he descended to the valley, and ascended the other side keeping the bee-line in view. On arriving at the spot, he saw his bees on the *Astrantia*, gathered a flower, smelt it, and there sure enough was the smell of his own honey so familiar to him.

Grion is at an elevation of 5707 feet, and the honey collected here is rather dark in appearance, and the flavour strong, but not at all disagreeable.

After a little more bee talk and a cup of tea, we left, promising to visit M. Bertrand, at Nyon, to see his bees there as well as his apiary at Allevays, where his hives had been cured of foul-brood. It was with great regret that we left Grion and its amiable host; but it was getting late, and we had two and a half-hour journey before catching the last train back from Bex. We followed the same road back, and passed two apiaries; but in these, the bees were kept on shelves in straw hives as well as plain boxes without frames, and trunks of trees hollowed out; and my companion told me that most of the bees were destined to be killed, the natives supposing the winters too severe to allow of any but the heaviest surviving.

The journey to Bex station was soon accomplished, and I parted with my pleasant companions, after having spent a most agreeable day in their company.

In my next I shall describe some of the other apiaries I visited, and what I saw there.—THOS. WM. COWAN.

**THE TWO NOBLEST THINGS.**—Mr. Matthew Arnold, it is said, borrowed his well-known phrase, 'Sweetness and Light,' from Swift. In his *Battle of the Books* the Dean makes Esop say, 'We have chosen to fill our hives with honey and wax, thus furnishing mankind with the two noblest things, sweetness and light.'

## Foreign.

### AMERICA.

#### TORONTO CONVENTION.

(Continued from page 289, col. XI.)

*What is the best time for Increase?*—The question was asked, 'If 100 colonies are to be increased to 150, will I get more increase by making the increase before, during, or after the honey-flow?' Prof. Cook said, before, if possible; if not, afterward; during, never. Miller, Poppleton, and others, strongly favored during the honey-harvest.

*Where shall extra room be given—over a case partly filled, or under it?*—J. B. Hall puts the empty sections under the partly filled ones, in the fore part of the season; but when the crop began to wind up, puts them on top.

*Single-story or Two-story Hives.*—Friend Jones, Prof. Cook, and Poppleton, held to one-story hives with frames spread out horizontally. I objected, and Mr. J. B. Hall was called on; he said he used hives ever so many stories high. There seems to be a wide difference of opinion in this matter.

*What shall we put around the entrance?*—A variety of plans was suggested. I gave our plan; Friend Jones mentioned ashes; but others said it made the grass and weeds grow too well. Mr. Hall prefers a board one foot wide, and two feet long. Although I did not have time to say so, I wanted to object to this board, on the ground that it would foster wasps and other like enemies of the bees.

By a unanimous vote, the Convention on the second day, was devoted to visiting the fair. Mr. Langstroth was among us; and after the building had been viewed and reviewed, Jones and Clark introduced the beemen to Mr. Langstroth. He shook hands with them as long as he could stand it, and then he was taken away to rest awhile. Knots of beemen were scattered about, and only through the honey-house, but among the beehives and implements, and on the grass outside. Small discussions were held around at various points; and such a friendly, pleasant meeting it were hard to imagine anywhere but among a lot of beemen. It seemed to be emphatically a season of giving and receiving knowledge. There was not much chance to argue with our Christian friends, because they had only to point to their piles of honey to back up their special beliefs and ways of doing things; and I verily believe that no one feature on the fair-grounds attracted so much general attention as the apiarian department; and the way the questions were asked by young and old indicated strongly the amount of information that was given to whole crowds of people by the beeshow. In the afternoon we held a session again.

*Bee-veils.*—This matter was discussed at length, and there was a variety of opinions expressed; but I believe it was pretty generally decided that there is nothing yet in the market that is just what we ought to have. Silk and Brussels net, woven of fine thread with a large mesh, makes the best material to put before the eyes; but it is objectionable, because it is so frail. If we had something made of very fine wire, with a mesh so large that a bee could not quite get through it, it would come pretty near filling the bill, although it would probably obscure the vision more than the Brussels net. No such wire-cloth has ever been made, to my knowledge. Somebody called me to order, asking how it was that I had so much to say about veils, when I claimed that I never used them. I replied, that my work and talk were principally for the benefit of the A. B. C. class, and those whom I would not dare to advise to work with bees without the use of the veil.

L. L. Langstroth. At this point Mr. Langstroth was

ush-red into the Convention; and at a signal every member arose to his feet, while our friend was conducted to the Mayor's chair. The afternoon was consumed in speeches of welcome from our Canadian brethren, and responses from different friends. Mr. Langstroth concluded with some interesting facts in regard to his earlier experience with bees and bee-hives. Friend L. was feeling extremely well, and his remarks were given in his happiest vein of humour. Those who have never heard him speak cannot well imagine the kind, pleasant, winning way in which he talks, and no one can for a moment doubt his disinterested love for all of the bee fraternity, as well as fervent and earnest devotion to the great God who gave us this world of wonders. In the evening, business was resumed as follows:

*Clipping Queen's wings.*—This, also, was discussed with much energy; while many prominent bee-keepers declared they would not have an unclipped queen, other apiarists there stoutly maintained that they wanted their queens to have the full use of their wings. I presume each man will have to fix his queens' wings to suit himself, as the matter stands.

*At what age should a Queen be superseded?*—Mr. Hall thought no definite age could be given. Some queens are young when they are old, and others are old when they are young; therefore we should keep queens just as long as they are profitable, and no longer. Mr. Langstroth thought that it seldom paid to keep them beyond two seasons, and also that the Italians generally reared their new queens as soon as the old ones began to fail.

*Best method of feeding Bees.*—Mr. Jones advised granulated sugar, and recommended tilting the hive back and pouring the feed in the entrance in the evening. Mr. Locke recommended the Mason fruit-jar, with the cover perforated with a number of holes.

*Does Foundation deteriorate by being kept?*—Mr. Jones said it becomes hard on the surface, so that the bees find difficulty in manipulating it, but that if the sheets were dipped in water, just as hot as it could be without melting the foundation, they would be annealed, as it were, and would be worked by the bees just as quickly as if it were made the very day it was put into the hive. Others related their experience in regard to using old and new foundation; and while some found it to answer well after it was a year old, others strongly objected. Friend Jones said a bee-keeper could make no better investment than to hang frames of foundation in the hives in fall, so as to get them partly built out, or, at least, to get the bees to go over them before winter; these sheets would then be worth double price for use in the spring. From what experience I have had with this partly drawn out foundation, I should quite agree with friend Jones. The best plan of cleansing wax is to keep it some time melted in deep tanks. The finest wax can be dipped off first, to use for starters in section boxes, and the lower grades for brood-rearing; even that which contains considerable dark matter would answer very well for wired frames.

The third day was commenced by a discussion in regard to moth worms.

*What is the best way of preserving the frames from the ravages of the Moth?*—Many different experiences were given, and some of the Southern friends were inclined to think that the moth worm they have is somewhat different from the one we have. Prof. Cook replied, that only one bee-moth was known to entomology. Different reports seemed to be caused mainly by the difference in temperature. Where the combs are kept a little distance apart they are seldom troubled much, even if left in the open air. Friend Jones suggested, that in building a honey-house the joists be put just the right distance apart, so that combs may be hung between them, resting on strips so placed as to catch the end of the top-bar; then when placed a little apart they are

right under the eyes, or, rather, over the head of the bee-keeper, and he can examine them at a glance, and remove any single one without troubling the others. I agree here, and would warn bee-keepers about leaving combs tumbled around carelessly, or piled up one on top of another. This latter method seems to be the very best way for propagating the moth.

*Right temperature for a Bee-cellar.*—Mr. Jones used to think that 40° was about right, but now prefers from 45° to 50°.

*Water for Bees in Winter.*—Prof. Cook says they tried giving bees water from a sponge in the winter, and colonies so watered were carefully marked, and every one of them had dysentery badly, while others came out healthy. Considerable discussion was brought out in regard to ventilation of bee-cellars.

*Enamel cloth for Bees in Winter.*—This matter was pretty fully discussed. While some think it harmful, others winter with a non-porous cover, without any trouble. Mr. McKnight prefers ground cork for an absorbent, placed over the bees. The general friendly feeling that existed among the bee-friends present found vent in singing the doxology, before we adjourned for dinner. In the afternoon, the subject of—

*Packages for shipping Honey* was discussed. Mr. Muth, with his large experience, gave some valuable facts. He said great losses were constantly being sustained by shipping honey in poor barrels. Second-hand barrels made a large amount of trouble. Friend Jones said he had also been troubled to get thoroughly tight barrels.

The Convention will meet next year in Rochester N. Y. The time is not yet decided on. I predict a larger gathering than we have ever yet had.—A. J. Root (*Proceedings for October*).

#### BURMA.

There are many kinds of honey-bees in Burma, India, both large and small. Every freshly flowering tree or shrub is soon covered with swarms of bees of various sizes and colours, and their humming wings are very musical.

There is little or no effort made to domesticate them, though there would seem to be but little difficulty in doing so. Whatever attempts have been made have been attended with some success. Some tribes of natives care for certain trees where they find swarms housed, stopping up the entrances, save a small place for the bees, to shut out enemies, or surrounding the tree with sharpened sticks to keep away Bruin, who is as fond of honey here as his brother in America.

The bee I am now speaking of, and which I will designate as No. 1, resembles, as far as I can judge, the domestic bee in America very much, speaking generally. It has three yellow bands, is about the size, and as lively and social as the home species. The honey and brood are deposited in any safe hollow place, usually in trees, and, of course, the flavour of the honey depends much on the kind of flower from which it is gathered; but it is very good, and much sought after. The bee is very industrious, and of a peaceable disposition, and will seldom molest one, except its nest be attacked, when it knows how to sting as sharply as its mate over the sea. The natives say, the time for taking the honey is the full moon during the dry season. The swarms are usually small, a few pints only, and a few pounds of honey is the most obtained from any nest. These bees are often seen flying through the air in a bee-line for some distant home, and in old forests are very abundant. The bears often find them, and wrench off, if able, large splints from the tree with their teeth and claws, to get the honey; but many trees, as varieties of the ebony, defy the teeth of the strongest bear.

I see no reason why this species could not be domesticated, and become very profitable servants. The experiment has never been tried, to my knowledge. A swarm

of these bees took up its lodgings under the desk in the office of an agent of a timber company here, and remained there for a long time, troubling no one, though in the same room with numbers of people.

The second kind of bees is similar to the above, though perhaps a little smaller. This variety builds its nest under, or in rocks. The swarms are usually much larger than No. 1, and resemble those at home more in size of the swarms, and kind of honey produced. The honey is very fine flavoured, and abundant. This variety is, however, much less numerous than No. 1.

No. 3, perhaps, ranks first in importance in the province. It is a large bee, about one-half an inch in length, rather small around in proportion to its length, long-waisted, and bright red and yellow. He is a gay fellow, with a fierce sting. He attaches his nests to the under side of great limbs of the dammer-oll tree, and on no other kind that I am aware of. There are often from fifteen to twenty nests on a single tree. As the bees occupy these trees from year to year, the trees become valuable property, and their owners collect only a portion of the honey each year, as, if some nests are left, they will return again to their old home after the rains. During the rains they 'go west,' probably to some dry country, or of less rain. These nests are very large, from two to four feet in length, and one or two feet in depth. The natives climb these grand old trees in the night time, smoke off the bees, and cut off the comb into a basket, and let it down to the ground with creepers or vines—a perilous operation. The honey is rather rank, but is much sought after. The wax has a ready sale.

No. 4 is larger than No. 3, with a similar shaped body. The back is, however, dark brown, and the belly and thorax jet black. The honey of this bee is much better flavoured than that of the above; and one nest of this bee is found in a place, which is usually some giant creeper in a dense thicket of trees. The comb is often from two to five feet in length, and from two to three feet in depth. This bee is very fierce, and woe to the native who dares to attack him without due caution. I saw a native on one occasion assay to riddle one of these swarms, about fifty feet from the ground. The vine to which it was attached was large, and twining in and out from tree to tree. The bees took the initiative in the battle, and the native was soon making the best of his way down the vine to safer quarters. But the bees were too much for him, and he dropped some twenty feet to the soft earth; yet the bees kept his trail and set on him at the foot of the tree. He was nearly naked and they had a fair chance at him. The poor fellow shot out from under that tree with a good deal of agility, and took to a stream of water near by; and only by running and ducking under the water, and splashing it about, did he finally escape.

No. 5 is similar to the above, though not found in such large colonies. Its prevailing colour is reddish, and some parts are light red; sting very badly. The peculiarity of this bee is, that it always places its nest so as to receive the rays of the rising or setting sun. It also builds on large vines. The honey is excellent, and much sought for. Nos. 3 and 4 build only one nest in a place, and do not seek the same place from year to year, as do the second kind described.

No. 6 is a small bee, which selects a small limb on the orange-tree, or the pendulous end of the bamboo, for its home. The swarms are small, and the comb is seldom more than one or two quarts. The comb is irregularly shaped, and a part is placed above the limb to which it is attached, and so shaped as to form a watershed to the brood below. The comb is very white, and the honey sweet and delicately flavoured. The bees are not much larger than rice kernels, and their sting causes very little irritation. They seem to rely on the position of their nests for protection. There are other kinds of this species of tiny bee, each having its peculiar ways, but of little

importance, save as a delightful study to those interested in them. They are found in small colonies only.

The last kind, No. 7, I will mention, seems to be a distinct species of bee from all others. This kind is found in large colonies, and in some parts of the province is very numerous. The bee is about the size of the last variety mentioned, dark-coloured, with white-tipped wings, and has no sting. The wax is very valuable, and forms a considerable article of trade. It is used for stopping leaks in boats, and similar purposes. The honey is acid, and not used. This bee builds covered ways to its nest, and one often meets these tiny covered ways projecting from a few inches to a foot from the tree in which the nest is. The tree most often occupied is the banyan, with its many openings in the trunk and roots. This little fellow, though he cannot sting, is not a favourite; for, attracted, I suppose, by the perspiration of the body, he seeks an entrance into the eyes, mouth, and nose, or crawls over the hands and person most persistently, though lots of his fellows die in the attempt, and the tickling sensation is very annoying.

The bee of the hollow tree is our favourite, perhaps because he reminds us of the dear old home. In any case honey here seldom tastes like that we used to bring away in tubs and pails from some grand old forest-tree in New England, when the golden rod in bloom told us boys that fall was upon us.

January, February, March, and April, are the honey months in this land, as the many forest-trees are a mass of flowers, sweet-scented, till the air is heavy with sweet odours, which are almost overpowering. Then the bees are most lively, and are the one thing that shows enterprise and activity in this beautiful land. — A. B. SKER, *Empire, British Borneo, Oct. 26, 1882. (Gleanings for November.)*

## ASSOCIATIONS.

### BRITISH BEE-KEEPERS' ASSOCIATION.

The next quarterly meeting of the Country representatives will be held at 105 Jermyn Street, on Wednesday, January 16th, at five o'clock in the afternoon. Notices of motions for this meeting must be sent to the Secretary, J. Huckle, King's Langley, not later than Wednesday, January 9th. A Conversation will be held at six o'clock. Subject for discussion, 'Foul Brood,' by Mr. S. Simmins, Rottingdean, near Brighton.

Committee meeting, held at 105 Jermyn Street, on Wednesday, December 19; present, T. W. Cowan (in the chair), Hon. and Rev. H. Bligh, Rev. E. Bartrum, Rev. G. Rayner, Rev. F. T. Scott, J. M. Hooker, D. Stewart, W. O'B. Glennie (treasurer), and the Rev. H. R. Peel (hon. secretary). The finance committee presented a statement of accounts, showing cash in hand, £37/10s. Resolved unanimously, 'That the loan of 10*l.*, due to each member of the committee, be paid without interest.' The Secretary reported that sixty-five persons were still in arrear with their subscriptions for the current year. Resolved, 'That the Secretary make an appeal for the payment of the same, and enclose a post-card requesting each member to state whether they would continue their support to the Association or not.'

The Secretary reported that the exhibition of honey was specially provided for in the Food Section of the International Health Exhibition to be held at South Kensington in 1884. Resolved, 'That the Rev. H. R. Peel, D. Stewart, and J. M. Hooker, do form a sub-committee to consider the necessary arrangements for the exhibition of honey, &c., at the International Health Exhibition, and to report to the next committee meeting.'

The following letter was read in regard to the awards made in the recent Bligh Competition:—

*Silver Street, Lincoln, 21st Nov., 1883.*

SIR,—I am desired by my client, Mr. G. T. Melbourne, of Nocton, to protest against the unwarrantable decision of the Judges in the Bligh Competition, and to inform you that, unless the First Prize is remitted before the 30th inst., he will commence legal proceedings to compel compliance with his request. As Mr. Melbourne assures me that he shall be able to prove that he has fairly won the First Prize, within the limits of the Competition, he feels that, in justice to himself, he cannot tamely submit to Mr. Hooker, though a life member of your Association,\* walking away with honours that do not belong to him, particularly as Mr. Melbourne's results are rather more than twice as successful as Mr. Hooker's, as shown by the balance-sheets published in the *British Bee Journal* of the 1st inst. It is not at all a matter of money, but simply one of justice and prestige, with Mr. Melbourne, who has done perhaps more than any one else to popularise bee-keeping in Lincolnshire. I trust that some satisfactory mode of arranging the difficulty may be hit upon without having to resort to litigation. I have only to add that my client believes that, though the Judges have endeavoured to award the prizes with fairness, yet they have been unknowingly deceived by plausible misrepresentations, or at any rate by a misapprehension of the facts of the case.

I am, your obedient servant,

FREDERICK ANDREW.

Resolved unanimously, 'That the Committee, having appointed judges to award the prizes in the Bligh Competition, and having no reason to doubt either their competency or integrity, regard their decision as final.'

The judges in this competition were requested to revise the rules, with the view to the arrangement of a second competition, and to report to the next Committee Meeting. In order to avoid delay in the transaction of the Association's business, and unnecessary expense in postage, &c., it was decided that all correspondence should be conducted by the Secretary, the Rev. H. R. Peel retiring from the office of Honorary Secretary, and offering himself for election on the new Committee for 1884. All correspondence in the future must therefore be addressed to Mr. John Huckle, Secretary, B.B.K.A., King's Langley, Herts.

*The Librarian.*—The Librarian begs to intimate that he has changed his residence to 'Langholm, Montpellier Road, Ealing,' and that he would be obliged by all communications being directed to him at that address.

#### BEDFORDSHIRE BEE-KEEPERS' ASSOCIATION.

A general meeting of members of the above Association was held at the 'Blue Ribbon Rooms,' Bedford (which had been kindly lent for the occasion), on Saturday afternoon, December 15th.

The Rev. N. Roys, Rector of Little Barford, was elected Honorary Secretary for the county in the place of the Rev. L. R. Whigham, Rector of Millbrook, resigned. Mr. Carter, of Bedford, was added to the committee; and it was decided that the Hon. Secretary should take steps to find how a ready sale for members' honey could be had; and he was empowered, if it seemed desirable to him, to subscribe on behalf of the Association to the central depot for sale of honey. Several skilled bee-keepers present kindly offered to visit gratis such bee-keepers in their own neighbourhood as would welcome them, and give advice upon bee-culture. This, it was hoped, would stimulate interest in bee-keeping and afford valuable information at no cost to the Association. The balance in hand of the Bedford B. K. A. is about 187.

\* The words, 'though a life member of your Association,' were erased in the manuscript.

#### KENT BEE-KEEPERS' ASSOCIATION.

##### DOVER DISTRICT.

A meeting of the Dover Branch of the above Association, was held at West Hougham, on Thursday, 13th Dec., the Rev. E. R. Orger, M.A., in the chair. There were present bee-keepers from Dover, Folkestone, Hougham, and River. The following resolution was carried unanimously:—'That this meeting is strongly of opinion that a bee and honey show in connexion with the Fruit and Flower Show at Dover in the coming summer will tend to promote the cause of Apiculture in this district; and as the bills announcing the Dover Flower Show will be issued in February next, the district Secretary is requested to forward a copy of this resolution to the Secretary of the Kent Association at once.'

An interesting discussion on 'supers' then took place. By the aid of these meetings we may hope for a good honey show at Dover next summer. The next meeting of bee-keepers will take place at St. Margarets if the Secretary get a favourable reply from the Rev. E. C. Huecy, to whom he has written on the subject—This to be decided by the Committee.

A discussion took place on Lectures, and it was decided that a lecture on 'Bees and Bee-keeping' should be delivered in the Schoolroom, at Church Hougham, or elsewhere in the neighbourhood, in the coming spring.—WYATT J. PETTITT, Hon. Sec., Dover District.

## Correspondence.

\* \* All Correspondents forwarding Letters for insertion in the Journal, Reports of Associations, Shows, Meetings, Echoes from the Hives, Queries, &c., are requested to direct their communications to 'The Editor of the "British Bee Journal," c/o Messrs. Strangeways & Sons, Tower Street, Upper St. Martin's Lane, W.C.'

#### OUR HONEY IMPORTS.

The value of honey imported into the United Kingdom during the month of November, 1883, amounted to the sum of £4087.

[From a private return sent by the Principal of the Statistical Office, H. M. Customs, to E. H. Bellairs, Christchurch.]

#### HOW TO PREVENT SWARMING.

Under this heading a correspondent (p. 293, Vol. xi.) inquires whether it be possible to prevent swarming, and also suggests that the queen be confined in a frame of excluder zinc. The only purpose for which perforated zinc can be depended on is that of entrapping undesirable, or confining other drones. Repeated trials have forced me to come to that conclusion. Laying queens will very often pass it, either for swarming or to get to other combs. When confined to a small space, her ovipositing powers are limited, when she soon becomes as small as a virgin queen, and finds little difficulty in passing the barrier. Before swarming too, a queen frequently becomes much smaller, as she lays but few eggs for several days previously.

I have had so many virgin queens pass the excluder, that I never use it for confining them, but hold them securely behind woven wire until I want them to fly: I then know that they fly only as I wish. Another very great objection to the practice of confining fertile queens on one or few combs is, that where they do not manage to escape with the swarm, they are often missing. A young one is found in their place, and possibly another has led off a swarm. As a rule, too, removing the queen does not give satisfactory results. I have tried all ways, and find that the best plan is to keep a good queen always breeding in about nine frames (standard). The colony is then ever ready to take advantage of any

opportunity our variable climate may offer. On the other hand, where the queen is confined or removed, the weather may suddenly change for the worse, and when the next gluck comes the stock will be much reduced, and one week of hard work will so thin their ranks, that the colony will be of little use without the addition of brood from other hives. If on hand, of course another queen could be inserted as soon as the first change occurred, but in all probability the bee-keeper would not give them one, hoping from day to day the weather would improve.

If your correspondent attempts to prevent swarming he will in many cases fail. But though we cannot as a rule prevent it, we can control that desire; at the same time permitting the bees to gratify their natural impulse of starting a new home; and by working together the bee-keeper will find his willing workers pay him much better than if he thwarted their wishes.

My method of 'swarming without increase' is as follows. When a colony working in sections is on the point of swarming, I remove the whole of the brood frames, and shake off every bee into the hive again, and give them nine frames of *foundation only*; replace the sections, which are at once proceeded with, and the colony is as contented as a new swarm. The removed brood combs are given to other colonies that may need them, or are inserted where frames are removed for extracting. Thus others are benefited, while the vagrant colony has settled down to work with even more vigour. When swarms come out they are returned with all the other bees on to foundation as before. When it is not known from which hive the swarm comes (which is seldom), it is united with any other lot, whose combs are first removed and replaced with foundation. Where there are queen-cells on the brood combs, they should be excised before being added to other colonies.

I am very particular to state that foundation only should be given to the newly made swarms, because if put back on brood, the bees will soon want to come out again; and should empty combs be given them, the sections will be neglected for some time, whereas with foundation the queen will occupy the cells almost as soon as drawn out, and all surplus must be carried above.

The fact must not be overlooked that swarming is often brought about by the bee-keeper neglecting to give plenty of room in the sections. By proceeding as I have stated, swarming loses all its disadvantages, and no time is wasted in repeatedly looking for queen-cells on crowded combs, when often the most experienced will overlook one or more.

Referring to perforated zinc, I may say that I never use it to keep the queen from the supers, and never have brood in them.—SAMUEL SIMMONS, *R. Wingham, Brighton.*

#### DO TOMTITS EAT BEES?

There has been a long controversy in our local newspapers about tomtits eating bees, so I sent them an extract from my manuscript bee-book, which conclusively settled the dispute:—

'On November 20th, 1872, I saw on one of my bee-benches a number of wings, legs, stings, and outside-scales of the bodies of bees, I soon said, "The tomtit (*Picus aculeatus*) has been busy here." I had not noticed or seen it before that year; but about four o'clock I saw three tomtits eating my bees. One of them I watched, and saw him fly down on the alighting-board of one of my hives, he began tapping it with his bill. Shortly a bee came out to see who was there, and was immediately snapped up by the tomtit which flew with it into an apple-tree near the hive. He then bent the bee against the bough of the tree on which he stood until it was killed. Then the tomtit, with its right foot and beak, pulled the bee's wings, legs, stings, and head off, letting the rejected parts fall to the ground, and then ate the

dainty parts of the bee. The tomtit was soon down on the alighting-board of the hive again,—tap, tap, tap, and another bee came out to see who was there, then the same process was repeated. I saw him take five bees in this way in seven minutes, when I could stand it no longer. So I frightened the tomtit away, as I was afraid he might have the nightmare with eating such an enormous supper. The tomtits were eating my bees again before ten o'clock the next morning. So I brought out my gun and shot three of them; and in opening their craws I found them nearly filled with bees—one, head, antennae and tongue complete. This bird must have been very hungry, as they generally reject the head. I found no wings, legs, or stings, in the craws. It grieved me very much to have to kill these useful, beautiful, and interesting birds; but it required the patience of Job to see my pets, the bees, so mercilessly destroyed.'

Your experienced correspondent ('G.D.') is quite correct. The tomtit does little harm to the bees in summer, there being at that time such an abundance of insect food which the tomtit prefers. It is only when its natural food fails, that it attacks the bee-hives. Wishing all bee-keepers a very happy and successful new year.—WILLIAM CARR, *Newton Heath, Astoria, near Manchester.*

#### A BEE-KEEPER'S DIARY.

Thinking that you may deem the following worth inserting in your *Journal*, and your readers may consider it worth reading, I beg to send some particulars of my bee-keeping. As you will perceive, it is in diary form, and for about the same time as the diaries of the Bigh Competition. Not having the opportunity of attending to and examining my hives and feeding my bees in spring, I do not think I have succeeded as well as I otherwise might have, but I am satisfied with my success.

*June 20th, 1882.*—Commenced bee-keeping (previous to this year not having known the difference between a queen, a drone, and a working bee), by putting a natural swarm, received from a friend, into a bar-frame hive (10" x 12" x 10"), made out of an apicote-box got from my grocer free, and outside which I put a large box, which also cost nothing; the intervening space, about one inch, being filled with cork-dust (No. 1 hive). Gave bees six frames, two of which were nearly filled with foundation, and fed them with syrup made of 4 lbs. of sugar.

*July 10th of '82.*—Hived another natural swarm; also obtained from a friend a hive (10" x 14" x 14"), same plan as No. 1, but of new timber. The hive holds in frame at back of hive four 2-lb. sections; all my hives being made for working sections in this way (No. 2 hive). Fed No. 2 with 1 lb. of sugar-syrup.

*September 10th of '82.*—Took about 10 lbs. comb-honey from No. 1, but had to put 1 lb. of it into No. 2, which I thought had not sufficient store for winter. (N.B. the difficulty of putting a frame from No. 1 into No. 2 gave me a lesson to have all hives in apiary of such a size as that frames should be interchangeable.) Confined bees in each hive to five frames, and over quilt and fine thicknesses of carpet put a cork-dust cushion about 1½ in. thick; also same thickness of cork-dust cushion at back of division-board.

*April, 1883.*—Gave 1 lb. of a lb. at a time of barley-sugar bought at grocer's to each hive on a piece of excelsior-zinc on top of frames, and it seemed to answer very well.

*May.*—Fed both hives with sugar made into syrup (4 lbs. each).

*June 6th.*—Took 2 lbs. of honey from No. 1.

*10th.*—No. 1 showed strong signs of swarming; and to prevent this I on—

*14th.*—Changed bees, and transferred some combs with brood and honey from No. 1 into No. 3 (a Standard

bar-frame, larger than No. 1), and condemned No. 1, as I resolved to adopt the Standard hive (this hive is long enough to hold seven frames, and three frames for sections); and took 19½ lbs. comb and 3 lbs. run-honey.

19th.—Took 4½ lbs. from No. 2.

End of June.—Had swarm from No. 3 (old No. 1), and put them into No. 4. Fed No. 4 with 4 lbs. sugar syrup. No. 4 and subsequent hives contain ten frames, and three for sections.

July 3rd.—Took 14 lbs. from No. 2.

25th.—Took 8 lbs. in sections from No. 3, and 2½ lbs. from No. 2.

September 3rd.—Took 1½ in sections from No. 3.

October 16th.—Took 3½ from No. 3, and 1½ from No. 2. Found, as I considered, Nos. 2 and 3 then well supplied with storage for winter (a good deal more than they had last year); but No. 4 had not sufficient, and I gave them a frame of candy. (Transferred them to No. 5, as No. 4 had not been painted, nor space between walls filled with cork-dust.) Put cork-dust cushions over quilt and carpets, and at back of division-board, as last year, after confining bees to five frames.

October 28th.—Lifted corner of quilt of No. 5 (formerly No. 4), and found that all candy had been removed into cells, probably owing to mildness of weather, but I omitted to remove empty frame.

December 19th.—Again lifted corner of quilt of No. 5, and found bees hanging like a swarm in empty frame between the two combs. Query—When wintering bees, would it be desirable to give them an empty frame to enable them to cluster in this manner?

#### BALANCE SHEET.

1882.	Expenditure.	£	s.	d.
Two hives (including frames with Dr. Pine's metal ends, carpets, quilts, &c.) Cost of materials only, as I made them myself—				
7s. each	.. .. .	0	14	0
Gloves and veil	.. .. .	0	2	10
Foundation (say)	.. .. .	0	2	6
Sections	.. .. .	0	1	6
Sugar for syrup	.. .. .	0	2	8
Smoker (the Bligh competitors do not calculate this)	.. .. .	0	3	6
1883.				
Foundation (say)	.. .. .	0	2	6
Barley sugar and sugar for syrup	.. .. .	0	6	8
		1	16	2
1882.	Receipts.	£	s.	d.
6 lbs. honey	.. .. .	0	6	0
1883.				
June 6. 2 lbs.	.. .. .	0	2	0
„ 14. 19½ lbs. comb; 3 lbs. run	.. .. .	1	2	6
„ 19. 4½ „	.. .. .	0	4	6
July 3. 4 lbs. sections and 10 lbs. comb	.. .. .	0	16	0
„ 25. 10½ lbs. sections	.. .. .	0	15	9
Sept. 3. 1¼ „	.. .. .	0	2	7½
Oct. 18. 5½ lbs. comb	.. .. .	0	5	6
	Total receipts	3	14	10½
	Deduct outlay	1	16	2
	Profit from honey	1	18	8½
2 hives on hand as good as new (cost of materials)	.. .. .	0	14	0
Smoker, gloves, and veil (say)	.. .. .	0	4	0
Swarm of bees (say)	.. .. .	0	10	0
	Profit (say)	3	6	8½

If carpenter's time were calculated, the profit would be something less; but I have calculated the cost of Dr.

Pine's metal ends, and had I been in the Bligh Competition I would not have used them, as I should have gone on cheap box-made hives, which cost me nothing except the trouble of making. Not having sold any honey, I have put it down at 1s. per lb. for comb and run, and 1s. 6d. per lb. for sections, being the prices for which similar honey has been sold in the neighbourhood by bee-keepers.

The total product of hive No. 3 (formerly No. 1) for the year 1883 was a swarm and 38 lbs. of honey; and of No. 2, 22½ lbs. of honey. Total from two hives—a swarm and 60½ lbs. of honey.

The above result was obtained within five (bee) miles from the residence of your correspondent, Mr. Crosbie Smith; and had the weather been more propitious than it was during the white clover and lime blossom seasons, the product would have been considerably more, as scarcely any honey was gathered from the limes in consequence of continuous rains; and not near as much from the white clover as there would have been during finer weather. Indeed, I think no lime blossom honey could have been obtained from the hives, as near the end of the lime season I inspected the hives, and found all combs, brood-nest included, filled with honey, mostly unsealed, which I would have extracted if I had an extractor, but did not do so; and in about a fortnight, when I thought I could have taken a large quantity, I found all that had been unsealed was extracted by the bees.—Boz.

#### INDIAN AND JAPANESE WAX.

In your article on Bee-culture in British India, you draw a comparison between the export of wax from India and the export of wax from Japan. This is scarcely fair to India without some explanation. All the wax brought from India is, I believe, bees-wax, whilst the greater portion of the wax from Japan is vegetable-wax, the product, I believe, of *Stillingia sebifera*.—THOMAS B. BLOW.

#### BLACK HONEY.

Your correspondent, 'W. Crisp,' asks for confirmatory evidence as to black honey being gathered from the oak. I have no doubt he is quite right as to his conjecture, for last season, some time in August, I noticed the bees frequenting oak-trees in large numbers. I had previously taken some supers of perfectly bright-coloured honey, but two supers from skeps I took later on I found had been finished off with this nasty 'inky-looking stuff' which I must certainly did not find of 'most delicious flavour,' but with me it left a disagreeable and hot sensation in the throat after being swallowed. I therefore cut out the portions containing it, and fed it back to the bees mixed with syrup. The honey season was about over with me when this black stuff was being brought in, and I attributed it at the time to the bees frequenting the oak-trees. I had noticed bees on the oaks the previous season (1882) whilst staying at Ryde, Isle of Wight; but had no black honey in my own hives that year. With regard to bramble honey, I can say most positively that it is not black: my bees frequent the bramble in preference to almost anything, certainly of anything but clover, and from it they obtain both pollen and honey. I have been curious to ascertain the nature of bramble honey, and from my observations with regard to some during the past two or three seasons I think it will be found to be a rather cloudy description of honey, somewhat darker than clover honey, and very much thicker, and more glutinous. It is the very essence of sweetness, but has, I think, no particular flavour to recommend it.—M. H. MATTHEWS, *Food Green*.



## HOME-MADE HIVES.

The possibility of even a 'clever' amateur making a hive has been 'stoutly denied' by one of your correspondents. Without any claim to being 'clever,' I beg to give my experience for the encouragement of those who are inclined to make the attempt. In order to get a good copy, I obtained a hive from Messrs. Abbott, and I have found it in all its essentials a very simple thing to copy. The two sides are 2 feet long by 8½ inches deep, and it has a front end only. The back end is loose, and slides in between the sides, as far as it may be required, thus forming a good dummy. The floor-board is also loose. To prevent the back ends gaping, I put a small wooden bar across. Now, surely, it does not require a very 'clever' amateur to make a box of this sort. I went to a grocer's and bought a good stout box, which had stuff enough in it to allow of its being knocked to pieces, and then put together in its proper form, for which I paid 8d.; and having converted it into a useful hive, I indulged in one a little more expensive, and procured a plank 12 feet long by 3 inches wide and 1 inch thick, for 1s. 6d., which supplied me with sufficient wood to make a real, good hive; and I have several of these hives in use, which have not cost me more than 2s. each for material. I use Abbott's Woodbury broad-shouldered frames, which cost 2s. 6d. per doz., and, as yet, I know of nothing so convenient and pleasant to use. As for supers, I make simple trays to hold seven sections each, three of which trays I place side by side on the top of the frames, and can remove anyone of them without disturbing the others. As my hives are in houses I have no occasion to make covers; but if I had to do so, I should use Crozgon's asphalt roofing, which is both cheap and good. When I began bee-keeping, I got a Langstroth hive, and I found the top bars of the frames were smeared with wax inside, and this was all the guide the bees had for building their combs; and I have never seen more perfectly regular combs than they built in this hive. If, therefore, any cottagers are inclined to make their own wooden hives, I recommend them to buy the frames, and not to go to the expense of purchasing comb-foundation, but simply to heat a little wax and brush along inside the top bar, and I should serve the sections in the same way. I would suggest that all Associations should keep a small stock of pattern hives, frames, sections, trays, and every requisite, to lend out as copies for cottagers to make by, or, if desired, to purchase. There is probably, at least, one advanced bee-keeper in every town who would undertake this trouble, and it would confer a great benefit upon the class, whom, above all others, the Associations are formed to serve.—A SUBSCRIBER.

## FREE OPINIONS.

Will you permit me to make a few remarks: first, I think there is a considerable amount of rubbish put in the *Journal* about double-walled hives, as to packing the sides up with cork-dust or chaff: this is not required, for if you stock two hives with equal number of bees with young queens, one with chaff or cork-dust packing, and the other with only air-space, where is the difference in spring? The reason I mention this is, because I am afraid it keeps people from beginning, as it makes it look a lot of trouble and mess, which I know, and I think you will say, is not required. As to candy, for my part I can't see that there wants any for bees. Packing bees close together, in frames, so that every frame is covered, I do not believe in, for they cannot move in a body as they would do if they had room, for I find if they have a frame or two more than they can cover, that after a cold spell of weather that they all move in a body to a different place of the hive: now don't you think it is for some good purpose on their part for their health? I should

think, in straw skeps for instance, the combs are not all covered, and they winter in them as well as where the combs are all covered. But ventilation I believe in for boxes of any sort, but not as that gentleman spoke of in the *Journal* of the 15th October, 'For a sharp draught to pass through all the winter.' But it would not be so if a small box or feeder were left on for the reek, it would get away in the boxes, and the combs would be quite dry, but, of course, skeps do not want any. I have seen, when a mild day had set in in winter, the sweat or reek from the bees run out of the entrances, and others with a super left on quite dry; I'm speaking of boxes. The less trouble people have the more they will speculate, and it is just so in bee-keeping, for I want to see it flourish, and all we want to try is the things that are really required, and do away with those that are not, for I know bees are very profitable. And there ought to be more encouragement amongst the cottagers: for at the late Ipswich show there was not a prize given for the poor cottagers that made hives, and I think there ought to be more notice taken of them, considering the hours they must have spent over them after their hard day's work.—A WELL-WISHER.

## ROYAL CELLS.—TRANSFERRING EGGS.—ORIGIN OF WAX.

*Royal Cells.*—Throughout last summer I kept a two-framed observatory-hive, always without a fertile queen, and usually queenless, the number of bees being maintained by occasionally substituting for an empty frame one full of brood from another hive. From these frames full of brood the bees constantly endeavoured to raise new queens, and almost as constantly commenced true royal cells, which, however, never got larger than those described by Huber as the sort in which Burnens saw the queen lay eggs. (*Nouv. Obs.* Vol. I, Letter IV.) I did not watch the building of these cells, but am positive they were built in the observatory-hive. I think, too, that on several occasions, after removing a queen from a hive, I have seen the cup-shaped, true royal cells increase in number. Huber mentions a case in which true royal cells were commenced when he made a stock queenless; but he mentions it in such a way as to show that he regarded it as very unusual.

Stocks with unfertilised queens seem also sometimes to commence true royal cells, although they do not wish to swarm. Huber (*Nouv. Obs.*, Vol. I, Letter III.) says that the workers in his hives with queens whose fertilisation had been retarded, frequently commenced true royal cells. And there is also the following note in the *Bee Journal*, Vol. X., p. 60:—'It is not at all unusual for bees, especially with infertile queens, to exhibit their anxiety by constructing queen-cell cups "ready for the egg," which they seem to be hoping for; but on the queen becoming fertilised the idea is abandoned.'

*Transferring Eggs.* Langstroth would have said that the bees sometimes do transfer them: in his work on the Honey-bee, 3rd edition, p. 219, he says, 'Huber has proved that bees do not ordinarily transport the eggs of the queen from one cell to another. I have, however, on several instances known them to carry worker eggs into royal cells. Mr. Wagner put some queenless bees, brought from a distance, into empty combs, which had lain for two years in his garret. When supplied with brood they raised their queen in this old comb.'

Langstroth then unhesitatingly admits the value of Huber's proof, that his bees ordinarily did not transfer eggs, whilst, at the same time, he not only admits that bees do transfer eggs, but even that queenless bees may sometimes transfer eggs to royal cells. Langstroth then clearly allowed that there might be great variability in the instincts of bees.

*Origin of Wax.*—The question of the origin of wax

and fat in the animal body has been taken up by physiologists, and the following instructive passage occurs in Dr. Foster's *Text-Book of Physiology*, 3rd edition, p. 394:—"Long ago, in opposition to the views of Dumas and his school, who taught that all construction of organic material, and all actual manufacture of protoplasm, or even of its organic constituents, was confined to vegetables, and unknown in animals, Liebig showed that the butter present in the milk of a cow was much greater than could be accounted for by the scanty fat present on the grass, or other fodder she consumed. He also urged, as an argument in the same direction, that the wax produced by bees is out of all proportion to the fat contained in their food, consisting, as this does, chiefly of sugar. And Lawes and Gilbert have shown, by direct analysis, that for every one hundred parts of fat in the food of a fattening pig, 472 parts were stored up as fat during the fattening period. It is clear, then, that fat is formed in the body out of something which is not fat."—H.

### HISSING FOR BEES.

The following extracts from an old work on Natural History may be interesting to some readers of the *Bee Journal*. The author was Abbé Le Plouche, born at Rheims in 1688. His *Spectacle de la Nature* was translated into English; the second edition of which was printed for James Hodges, at the Looking-glass on London Bridge, 1749, having as its title *Nature Delinced*.

In the third volume (pp. 25, 26) occurs the following curious allusion to the sense of hearing which bees were generally thought to possess, until a series of recent experiments has proved that as far as can be ascertained bees show no sign of appreciating sound. The book is written in the form of a dialogue between four persons much after the manner of Walton's *Complete Angler*.

*Prior*. . . . The most infertile and northern countries, such, for instance, as Lithuania\* and Muscovy, are peculiarly adapted to the rearing of bees. And though those little animals sufficiently secure to their owners the fruits of their industry, by that excellent form of government, and that exact order and harmony that is invariably preserved amongst them; yet by an instinct of nature they are fond, as it were, of their master's service, are as obedient to his signals, and attend him in as regular a manner, as a herd of cattle obey the directions of their driver. . . . Thus the proprietor of the bee-hives, with one single whistle, can summons all the bees in the village round about him, and by that well known signal conduct them sometime into one large bed of flowers, and sometimes into another, altering their situation from time to time as he thinks most convenient, that the flowers may have sufficient time to recruit their exhausted stores, and by that means afford the bees a fresh supply of sweets. With another whistle he reconducts them home upon the approach of night, or some impending shower.

*Chevalier*.—I can't think 'tis possible, Sir, for a large swarm of bees to be made thus tractable, and obedient to their master's call.

*Prior*.—This was not only a very common, but an ancient Custom in the East: And the Prophet *Isaiah*, when he compares the armies which the Almighty introduces into a Country, when he is determined to punish the Inhabitants for their Disobedience, alludes to a Swarm of Bees, which their Proprietor thus gathers together, or discharges by a Signal to which they are all accustomed: *The Lord*, says he, *shall hiss for the fly that is in the uttermost Part of the Rivers of Egypt, and*

*for the Bee that is in the Land of Assyria*. This Practice subsisted likewise in *Asia* in the fourth and fifth Centuries; and *St. Cyril* takes Notice of it, as a Thing that was no Novelty in his Time, and which he had seen frequently performed.—EDWD. J. GIBBINS, *Neath*.

### MR. HEWITT ON SYRIANS.

There appears to be great difference of opinion amongst those who have tried Syrian bees: one well-known bee-master describing them as 'truculent pests, too fierce for ordinary management,' whilst Mr. Hewitt has been renewing his advocacy of them as paragons of gentleness. This being so, will Mr. Hewitt be good enough to answer two or three questions, and so give the benefit of his experience a little more fully to bee-keepers who like myself are tempted by the prospect of eighteen frames continuously filled all through the summer with solid slabs of brood, and honey to match, but who consider that the acquisition of expensive queens, like the acquisition of a wife, 'is not by any to be enterprised, nor taken in hand, unadvisedly, lightly, or wantonly, especially when assured by many of her ladyship's familiars that she is likely, unadvisedly, lightly, and wantonly, to enterprised and take you in hand.

(1.) Are pure Syrians, upon the whole, when not smoked, as gentle and good-tempered as pure Lignrians? (2.) Are 'Syrian-blacks' (i.e. the offspring of a Syrian queen fertilised by a black drone) as amiable as pure black bees of average temper? (3.) What are the characteristics of the offspring of black queen and Syrian drone, in respect of appearance, temper, honey-getting, and prolificness? (4.) How far are the qualities of the first cross shared by a second cross, i.e. between hybrid queen and black drone, or black queen and hybrid drone?—W.

### BLIGH COMPETITION.

As a young bee-keeper, and a cottager of the labouring class, I would like to thank the competitors in the Bligh Competition, together with its public-spirited originator, for the effort they have made to show the public that bee-keeping is a profitable pastime. At the same time I think there is a great deal of truth in what Mr. Hewitt says. Who is there amongst us who could spare time to attend to artificial swarm-making, queen-raising, &c., as Mr. Melbourne did, or sell them as he did after we had got them;—at least, I could not. My bees have in a great sense to take care of themselves; they are located away from home, alongside of the railway, often not seen by me for days. My hours of work are from six in the morning to 5:30 in the evening, effectually preventing that style of procedure before mentioned, if I had the desire to adopt it. To my mind the production of honey and wax should be the principal thing aimed at. Another thing I should like to speak about concerning County Associations is this. It is well known that the Parent Association does give certificates to qualified experts that can give a stump lecture to a hall full of people. But most labourers would, to say the least of it, feel rather awkward in that position. Would it be practical for County Associations to do something of this kind; say have a private examination at some convenient time and place? Would it not raise Hodge without puffing of him, besides not driving him to the expense of a long journey to I don't know where: sleepless nights, and general fidgetiness for a week! It may be asked what good would it do? This is the answer, in the advancing state of apiculture, when many gentlemen keep bees, it is plain a man with some sort of certificate of competency stands a better chance of getting a good situation. In my own parish I am certain it would carry its weight in a case or two.—PLATELAYER, *Ruckinge, Ashford*.

\* Lithuania and Muscovy now form part of Russia.

## THE HONEY BEE.

The honey bee wanders from flower to flower, her labour begins with the day,

O'er fields of ripe clover: she stops at each bower to carry its fragrance away.

She labours incessant each bright sunny hour, you hear her brisk hum as she flies,

She sips the sweet dew of each opening flower, and carries it home to the hives.

So, you honey bees all, in the gay world of life, just copy this innocent fly.

She toils for mankind without anger or strife, you can all do the same if you try.

She flies far away to the valley below when the early spring flowers appear,

And from cowslip, or bluebell, or white-blossom'd sloe, she sucks the first-fruits of the year.

O'er briar, o'er bramble, through dingle and dell, far away from her home she must go,

And finds in her ramble the gay daffodil peeping out through the hoar-frost and snow.

The sunshine and shower her riches provide, giving sweet honey-dew to the rose,

And the pretty wild flower that decks the wayside receives a sweet kiss as she goes.

In her little green bower she yields up her power at the close of her labouring day,

And through life's sunny hours she has lived for the flowers, and dies when they're fading away.

So, you honey bees all, in the gay world of life just copy this innocent little fly.

She toils for mankind without anger or strife, you can all do the same if you try.

JAMES GOODYEAR.

[The above may be sung to Haynes Bayley's old ballad of 'The Buttery to a Gentleman.' The words have been composed by an aged blind man in the Strand Union, Silver Street, Edmonton.]

**BEE-KEEPING.**—At a meeting of the Natural History Society, held on Wednesday, Dec. 5, at the Institute, Wisbech, Mr. James Dann read a very instructive paper on 'Bees and Modern Bee-keeping.' Mr. Dann first traced the history of bees, showing that they had claimed the interest of man from the remotest age, being mentioned no less than thirty times in the Bible, and pointed out that bee-keeping had been a study for the past 300 years, as he proved, by referring to ancient books. Mr. Dann spoke of the queen-bee, her prolific breeding power, laying as many as 40,000 eggs in one season; he described the working bee, or honey-gatherer, from the laying of the egg to the grub, and the perfect bee; also the drone and its utility. He spoke of the cottager's system of bee-keeping with the old straw-skep and brimstone-pit; then the modern bee-hives and the honey-extractor; and, lastly, of the honey, the old squeezed and strained honey, and the pure extracted honey, comparing the old way and the new. He said it was like putting the nectar of the Olympian gods on a par with forty-rod whisky! He then referred to the various bee-keeping societies, especially mentioning the local Society, and the help it had rendered to the science; also to the grand success of the Lincolnshire Society, and their honey fair, this year pitching two tons and a half of honey. A vote of thanks was unanimously passed to Mr. Dann for his valuable paper. Mr. Dann illustrated his paper by exhibiting a skep, showing the manner in which bees built their comb, and a bar-hive, used in the modern and improved system of apiculture; also some honey extracted with the slinger.

## Echoes from the Hives.

*Rottingdean, Sussex.*—Except for a few days from the 4th of December, the weather still remains mild. On the night of the 6th, a heavy fall of snow occurred with frost, but all was gone within two or three days. On the 21st, the bees were out in great numbers, and though the occasional flights they have had so far have done them no harm, it is to be hoped more reasonable weather will prevent them flying much more until breeding can be safely stimulated. The warmth that has induced the bees to come out occasionally has also enabled them to bring their stores nearer the cluster. They will, therefore, be prepared for a spell of cold weather, should it come, as in all probability it will.—SAMUEL SIMMONS.

*Hunts, Somersham, December 24th.*—The weather during the past month has been very fine, but sufficiently cold to keep the bees in during the greater part of the month. On the morning of the 12th inst. we were visited by a terrific gale. When I went into my apiary, I found a stock topsy-turvy. The examination revealed a ruined stock. Unfortunately, the stock belonged to a friend. It was in a very light hive. I am pleased to say my stocks are in thoroughly substantial hives, such as all hive-makers should supply. Rain has fallen only on four days since November 24th. Snow fell on December 6th, but soon disappeared.—C. N. WHITE.

*Weston, Leamington, Dec. 27th.*—A fortnight ago a friend of mine gave me five stocks in skeps. He did not care to go to the trouble and expense of feeding them, as they were very short of food, he only wanted to keep one stock; so I fetched them home; fortunately, it was very mild weather, and there was no difficulty about the bees taking a little food and storing it. The last fortnight bees have been on the wing very much, and no doubt are consuming their stores fast. Tom-tits are a great nuisance here.—JOHN WALTON.

*Galusha, N.B.*—This has been one of the worst seasons that has been for many a year; a good many stocks brought home dead from the heather, and the most of them almost empty. I got nothing from the straw hives, and just about six pounds from the bar-frame ones.—JOHN ALLAN.

*Tinahely, Ireland, Christmas Eve.*—Bees, all out; their joyous notes of gladness greet your ear at every turn. Very fine, like summer. Some bee-keepers are already thinking of their live-stock for next year. Examined bees, without disturbing cluster, and found supply of candy and honey quite sufficient.—J. TRAYNOR.

## Queries and Replies.

**QUERY No. 729.** (Q.) 1. *Entrance to Hives.* How many inches wide should the entrance to hives be in winter (a) to hives with frames at right angles? and (b) parallel to entrance? The height of my entrances is  $\frac{1}{2}$  inch.—A. The chief requisite, after the hives are closed for winter, is *perfect rest*. The bees must never be disturbed, and all exciting causes must be absent. Now the more air you admit the more oxygen, which is not only an exciting cause to human life, but to bee-life also. When, therefore, we have admitted sufficient air to support life we have done all that is required. We always close our entrances by means of sliding blocks  $\frac{1}{2}$  inch, opening them to the full width of six inches when the weather is sufficiently mild and bright to enable the bees to fly, and closing them again in the evening, after clearing away dead bees and refuse with a long piece of wire. We should make no difference whichever way the frames are placed.

2. *Balling Queens in Uniting.*—A couple of weeks ago I put a lot of condemned bees with a stock of my own without removing any of the queens, expecting that the two queens would 'fight it out,' as stated in recent numbers of *British Bee Journal*. Contrary to expectation, the queens did not fight at all, but the workers in the stock seized the queen of the condemned bees, and formed themselves into a ball round her, and when I released her she was almost dead. I have no means now of knowing whether my own queen was not similarly treated by the condemned bees, as the weather is too cold to permit of any examination of the frames. How am I to know whether the bees may not now be queenless?—A. The queen of the condemned bees was seized by the workers of the hive and encased immediately on her introduction, their own queen being securely protected from harm by closely surrounding guard. This is almost invariably the case on the introduction of strange bees with their queen to an established colony. The encased queen is destroyed by the pressure of the ball of bees and suffocation combined. She is not stung to death simply because the embrace of the encasing bees is so close that they are unable to use their stings. The queen of the hive is safe. You may rest quite satisfied of this. Do not attempt an examination unless you wish to destroy the colony.

3. *Bottom of the Box of Chaff.*—Would you disapprove of boarding the bottom of the box of chaff which covers the quilt in winter? Is there no danger of the bees cutting the quilt and ascending into the chaff?—A. A piece of open meshed canvas forms a better bottom for the chaff-box than boards. The bees will never gnaw through this, nor the quilt either. The latter should consist of several thicknesses of woollen material.

4. *Preventing Dysentery.*—How can one who has no extractor do with frames containing unsealed honey so as to prevent dysentery?—A. Extractors can be obtained at so low a price that we cannot understand why the possessor of a few hives should be without one. If the case you put were our own we should simply leave the unsealed honey, trusting to the chapter of accidents rather than disturb the hive.

5. *Borage.*—When should borage be planted for bees?—A. At any time, from the middle of February throughout the summer and autumn months. It is very hardy, thrives best in a moist soil, should be sown thin, not transplanted, and is about the best bee plant grown.

QUERY NO. 730.—(A. S. J.) *Doubling.*—It seems to be generally admitted that it is more profitable to extract honey than to take it in the comb, and it appears to me that in order to obtain all extracted honey the hives must be on the doubling principle, but I can find very little information on this subject in any of the books on bee-keeping, will you therefore state your opinion on this matter; also describe the process of doubling, and inform me in what books this method is fully dealt with? How is the upper box kept secure; which is the best bar frame-hive for this principle; and from whom may it be obtained, as I cannot find hives adapted for doubling advertised, except those of the Great Hampshire Bee-Farm, near Stockbridge?—A. There is no doubt that a much larger amount of honey can be obtained by extracting than by supering for comb-honey. Professor Cook, in his *Manual of the Apiary*,—which you would do well to consult—asserts that "By the use of the extractor, at any time or season, the apiarist can secure nearly, if not quite double the amount of honey that he could get in combs." We must bear in mind, nevertheless, the difference in price between extracted and comb-honey, the former being worth in the market barely two-thirds as much as the latter. The extra cost in labour should also be considered. With a view to extracting, the doubling system is the best, and it is very simple. You will find it described in Root's *A B C of Bee-Culture* and also in Mr. Cowan's

*British Bee-Keeper's Guide*. These books may be obtained of Mr. Huckle, of King's Langley, Herts. Messrs. Pines and Son, of Maldon, supply a good and cheap hive, worked on the doubling system, and no doubt other vendors of hives do the same. The only thing required is that the hives and frames should be of precisely the same size and shade, in order that all parts may be thoroughly interchangeable. There is no better hive for this purpose than one taking ten or twelve of the British Standard frame. The upper box is quickly proportioned to the lower one by the bees; and the weight of the roof, or cover, renders all secure. The method of doubling usually adopted in this country is to select a couple of strong colonies in equal sized and similar hives, and from one of these to remove all the combs supplying their place with frames of empty comb, or foundation, on to which the bees are brushed or shaken. Their combs, containing brood and honey, are then placed in an empty hive and at once set upon the other selected colony, where, from the brood hatching out above and below, the population becomes enormous, and the upper frames are soon stored with honey. These are repeatedly passed through the extractor, and returned to the hive. Should the queen ascend and deposit brood in the upper hive, the lower one will also require its outside frames, at least, to be extracted. Much, however, will depend upon the influx of honey, the fecundity of the queen, the season, and the locality.

QUERY NO. 731.—(W. ABBOTT.) *Description of Swarms.* Towards the end of July, 1881, I had two swarms, rather small. The autumn being favourable, they collected a little honey, which I supplemented by a constant supply of crushed sugar. In 1882, each cast two swarms, but immediately afterwards they each deserted their hives. Whether they went into their swarms, which were close beside them, or not, I could not discover, but my impression is that they did. Would you kindly say what may have caused them to desert, as each left a quantity of honey after them?—A. It is very probable that the swarms returned to the parent hives. The cause of desertion we cannot state unless the conditions are fully given. It might have been from excessive heat, or want of shade, or from a dearth of honey; they may have been attacked by robbers, and driven from their hives; or, indeed, any one of many other causes may have produced the result. It is always best to place the new swarms at a distance from the parent hives, in order to prevent confusion, disorder, and robbing. If your mishap occurred from robbing, during cold and dull weather, the return of sunshine, and the renewal of income, will account for the honey left in the hives.

QUERY NO. 732.—(E. HOLLIDAY.)—1. *Number of Bar-frames.*—Does the number of frames allowed in a bar-frame hive for breeding depend on the neighbourhood, or on what does it depend?—A. And how many frames would you allow for a cold or uncertain neighbourhood?—A. The number of frames depends upon the locality, and also upon the strength of the stock, and the prolificness of the queen. From eight to twelve Standard frames is about the number.

2. *Excluder-zinc and Drones.*—In the case of Abbott's Combination hive, how is the queen confined to a certain number of frames without confining the *drones* also that may happen to be behind the excluder-zinc?—A. The excluder-zinc which confines a queen will necessarily confine drones, but the combs on which the queen is confined should not contain any drone-cells, and thus no drones are produced to be confined.

3. *Transferring Combs.*—I have some comb, taken from a skep, tied in frames, and wishing to make the most of them, I did very little cutting. Will the bees repair and fill up spaces from  $\frac{1}{2}$  in. to  $1\frac{1}{2}$  in., or should the pieces of comb fit close to each other.—A. In transferring combs from skeps to frames they should be neatly

squared and crowded in tightly, and will be joined by the bees into one comb. Discard all drone comb, except three or four inches in an outside frame.

4. *Syrup.*—Having prepared more syrup than I wanted for supplying sealed store in the autumn, I put the syrup in bottles. Will it do for stimulative feeding in spring? *Denerava sugar* with a little vinegar and salt.—A. Your syrup prepared for autumn feeding must be largely diluted for spring feeding.

5. *Queen Cells.*—When bees build queen-cells, having a queen, is it a sign that the queen is old?—A. Building queen-cells in spring and summer is a sign of swarming being about to take place. But after the swarming season has passed, it is, especially when drones are present, a sign that the queen is worn out.

**NOTICES TO CORRESPONDENTS & INQUIRERS.**

A **YOUNG BEE-FARMER.**—*Bees Visiting Peach-trees in a Green-house.*—If the weather is cold it is not probable that the bees will leave the hive; but if it is warm there will be no difficulty in getting them to visit the flowers, especially if they are enticed by a small piece of honey-comb, taking care that all the windows are open to allow them free egress.

A. F. RAMSDEN.—*Moving Hives.* This may be done at the present time. Care should be taken to fix each frame firmly, so that the jarring in travelling may be minimised; attention should also be paid to proper ventilation. (See index to previous volume.)

BRIAR TOR.—Heather honey can be extracted a few days after it has been gathered by the bees. If not done at that time it solidifies to that degree that there is great difficulty in causing it to leave the cells. It would be advisable to rely on supers for heather-

honey. There is, however, not the same difficulty in extracting clover honey. (See p. 182, vol. XI.)

MONA.—*Transferring.*—The best time for transferring bees from a skep to a bar-frame hive is about twenty-one days after swarming. The amount of food in the combs will determine the necessity of feeding.

C. W.—*Dysenteric Symptoms.*—Your description does not seem altogether to indicate dysentery, especially as the weather has been warm enough to give plenty of opportunities for cleansing flights. Probably breeding is going on in the Ligurian stock, hence consumption of pollen, and more profuse excreta than in other stocks. If on examination (which we should recommend) you find dysenteric stains inside the hive, give a cleansing flight in a warm room, as advised to F. A. G.

F. A. G.—*Mouldy Combs.*—Your combs getting mouldy and your bees dying from dysentery, both arise from one cause, viz. dampness. The remedy is to ascertain the cause, which may be entry of wet or want of exit for the moisture from the bees; and having ascertained it, to remove it by stopping the entry of wet, or giving increased ventilation by more porous quilts; also reduce the size of the hive by removing the outside frames not covered by bees, and close up the division-boards. If you can put the hive bodily into a large box of wire-cloth or perforated zinc, and bring the whole into a warm room, at the same time giving a feed of warm syrup with salicylic acid, it will do the bees a great deal of good.

T. T.—*Mouse in a Hive.* The skeleton is that of a mouse. With your description of the small entrance to the hive, there is a difficulty in unravelling the mystery as to how it got inside.

BEE-SWING.—IN OUR NEXT.

**EDEY & SON'S**  
**Humane Bar-Frame Hives, and Bee-keepers' Supplies,**

MANUFACTURED ON SCIENTIFIC PRINCIPLES,

By an experienced Staff of Joiners,

WITH THE AID OF MODERN STEAM-POWER MACHINERY.

'Hives of carved cork.'—VIRGIL.

**No. 1.—CORK HIVE.**

Cork, from its non-conducting properties, has for centuries been acknowledged the best known material for inner walls.

Price of No. 1 Hive, with all modern improvements, 27s. 6d.

**No. 8.—COTTAGER'S HIVE.**

The cheapest complete Hive manufactured. Has double end walls, 9 Standard Frames, Foundation Guides; Wide Frame containing 6 Sections, with Foundation and Separators; Zinc Queen Excluder, Floor-board, Plinth, Entrance Slides, Poreh and Cover. Price 10s. 6d. Also Hives from 6s. to 30s.

**BEEES.**

Special care is taken to insure Purity and Prolific qualities, in our strain of **LIGURIANS**; they are of remarkable docility, and equal to any imported at the following low prices:—September, 5s. 6d.; October, 5s. **BLACK QUEENS**, 2s. 6d.

**GLASS JARS** specially made for Extracted Honey.

We beg to call attention to our **WHITE FLINT JARS**, they are giving universal satisfaction, and are cheaper than any other make of equal quality. 1 lb. 17s. 9d.; 2 lb. 24s. per gross. Air-tight Cork-lined **STOPPERS**, 6s. per gross.

**FEEDERS.**

The **COVERED SIMPLICITY**, with Glass Slider, 1s. each. **SIMPLICITY**, No. 90, 4d. each. **BOTTLE** and **STAGE**, 1s. each.

**LISTS FREE OF ALL BEE FURNITURE.**

**THOS. EDEY & SON, Steam Joinery Works, St. Neots, Hun's. (19)**

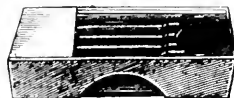

**NEW-YEAR'S GIFTS.**

SOME of the pretty CHINA HONEY BOXES and JARS, as sold at the Knightsbridge Show, may be obtained of Mr. J. HUCKLE, King's Langley. The Boxes are suitable in size for holding 1 lb. Sections, and the Jars about 1½ lbs. of Extracted Honey, both are very ornamental and convenient for the Breakfast Table. Price, Boxes 2/6 (3/0), Jars 1/0 (1/3). Can be forwarded by Parcels post on payment of the cost of carriage, amounting to 6d. for one Box; two Boxes, 9d.

**Bee-keeping as a Business.**

STUDENTS are accepted at any time at the GREAT SUSSEX BEE FARMS on reasonable terms. Almost anyone can keep Bees; but it is a fact that not one in fifty will ever make it a profitable business unless Practical Lessons are taken for at least one Season on a large Bee Farm, conducted on modern principles. Without such instruction, it takes years to acquire the knowledge necessary to ensure success in this most fascinating and health-giving pursuit.

As the Proprietor devotes his time entirely to the production and sale of Honey and Bees, those studying with him will have his undivided attention, and will be qualified to start out at once on a recognised system of management; thus saving much needless expense and labour conducted in a wrong direction. Particulars on application to S. SIMMONS, Proprietor, Great Sussex Apiaries, Rottingdean, Brighton. (47)

Bronze Medal awarded for Straw Skeps at the Great Crystal Palace Show, 1875.

Seventeenth Edition. Price One Shilling.

**SEVENTY POUNDS A-YEAR:**

HOW I MAKE IT BY MY BEES.

By the late J. W. PAGDEN.

Also, by the same Author, price Sixpence.

**EARLY ARTIFICIAL BEE-SWARMING.**

No watching required.

Apply to Mrs. J. W. PAGDEN, The Chestnuts, Alfriston, Sussex, by whom the same manufacturers of 'Economic Bee Furniture' are employed as formerly. (40)

**AGENTS FOR BEE-KEEPERS' SUPPLIES.**

WANTED.—Two or three energetic Men in every County to undertake AGENCIES for the SALE of BEE-KEEPERS' SUPPLIES of the highest class. A rare opportunity for men having spare time and an acquaintance with Bee-keepers. Liberal commission. For terms and full particulars apply to ALFRED H. HAYNES, 125 Houndsditch, London, E. (54)

**METAL ENDS FOR FRAMES.**

NOTICE.—We beg to call the attention of all Bee-keepers to our latest improvement in Metal Ends for Frames, which entirely supersede the use of Zinc Runners and Broad-shouldered Frames, while their weight and fixing keep the Frames perfectly perpendicular.

Price, 10d. per doz., 9s. per gross.

Specimen sent on receipt of two stamps.

All Hives above 10s. each are fitted with these Ends.

Illustrated Catalogue free on application.

Silver Medal, Knightsbridge, 1883.

First and Second Prizes at Angley, Coventry, &c.

**C. G. HARRISON & CO.,**  
Hive Makers and Dealers in all Apianian Appliances,  
HALESOWEN, WORCESTERSHIRE. (60)

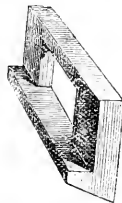

**Imported Cyprians & Syrians.**

THE undersigned will visit Cyprus and Syria this Winter, and bring back full Colonies and Nuclei, with only selected Queens, part of which will be raised by himself in March. Fine Queen sent before June 1st, 22s.; during June, July, or August, 20s.; after September 1st, 18s. These are to be Selected Queens of fine grade. A limited number of exceptionally Fine Queens can be supplied at an additional price of 5s. each.

**Imported Carniolans & Italians.**

Fine Queen before June 1st, 9s.; Extra Fine, 12s.; during June, 8s.; Extra Fine, 10s. I accept and send out none but Choice Queens. The very choicest Selected Queens are those denoted above as 'Extra Fine.'

Any Six Queens, 5% off; Ten Queens, 10% off.

Carriage prepaid. Safe arrival guaranteed.

**A RARE CHANCE!**

Cash orders till Jan. 15th, 10% less than above prices.

FRANK BENTON, Georgen St. 8, Munich, Germany. (50)

**THE BRITISH BEE JOURNAL.**

VOL. XI, MAY—DECEMBER, 1883.

Containing 300 pages of Useful and Instructive Information to all Classes of Bee-keepers.

IT IS ACCOMPANIED WITH A COPIOUS INDEX.

The Contents include Papers on—Hives: Twin, Triple, Stewarton, Observatory, Anglo Cyprian, Cheap, Single and Double Walled, Skeps—Bees: Blacks, Ligurians, Carniolans, Cyprians, Holy Lands, Syrians, Humble and Wild—Honey and Wax—Feeding, Extracting, Queen-raising and Introducing, Nuclei, Uniting, Bee-farming—Bee-stings and their Remedies—Bee Flowers and their Names—Candy, Syrup, Sugar-cake—Smokers and their Fuel—Lectures—Reviews—Useful Hints from Month to Month—Correspondence on all Apicultural Matters—Queries and Replies—Notices to Correspondents—Reports of Associations, Shows, and Honey Fairs—Bee-culture in Europe, America, India, Australia, &c.—Translations of the best Articles in Continental Bee Periodicals—The Zurich Exhibition—Papers read at Conversazioni—Biographies of Celebrated Bee-Masters—Descriptions of Apiaries—History of County Associations—Reports of the Bligh Competition—Presentation of Testimonial to Mr. Abbott, &c., &c., &c.

Neatly bound in Cloth, price 5s.; post free 5s. 6d. Cloth Covers for binding the Volume, 1s. each.

\*.\* All the back Numbers of this Volume are still in print.

Vols. 6, 7, 8, 9, 10, and 11. price 7s. each, post free 5s. 6d., may be obtained of J. HUCKLE, KING'S LANGLEY, HERTS; KENT & Co., PATERNOSTER ROW, LONDON; and all Booksellers.

# THE BRITISH BEE JOURNAL

*Communications to the Editor to be addressed 'STRANGEWAYS' PRINTING OFFICE, Tower Street, St. Martin's Lane, w.c.'*

[No. 138. VOL. XII.]

JANUARY 15, 1884.

[PUBLISHED FORTNIGHTLY.]

## Editorial, Notices, &c.

### INTERNATIONAL HEALTH EXHIBITION.

At the closing ceremony of the very interesting and highly successful International Fisheries Exhibition held last year, the Prince of Wales suggested that the buildings which had been erected should be utilised for holding other exhibitions of an equally comprehensive character. The Prince mentioned three topics which appeared to him to be of the greatest importance. These were health, both bodily and mental, industrial inventions, and the growing resources of our colonies and of our Indian Empire.

To carry out the ideas of the Prince an Executive Council has been formed; and it has been determined that the Exhibition shall be held under the patronage of Her Majesty, and under the presidency of H.R.H. the Prince of Wales; that it will be opened on the 1st of May, and will continue open for a period not less than six months. The classification is very simple. The main divisions are, Health and Education. The first and larger division is distributed into five groups, - Food, Dress, the Dwelling-house, the School, the Workshop, as affecting the conditions of healthy life. These groups again are subdivided into different classes. Under the third of these classes of the first group will be exhibited, 'Food produced by insects, such as Honey, &c.'

This opportunity of exhibiting the produce of bees having been brought before the last monthly meeting of the British Bee-keepers' Association, it was resolved, 'That the Rev. H. R. Peel, D. Stewart, and J. M. Hooker, do form a sub-committee to consider the necessary arrangements for the exhibition of honey, &c., at the International Health Exhibition and to report to the next committee meeting.' Messrs. Hooker and Stewart have had a preliminary interview with the Food Committee, the result of which we hope to give in our next issue.

### ASSOCIATION DEFICIENCY FUND.

The following is a further list of new Life Memberships and of Donations to the Fund:—

The Earl of Harwood; R. J. Hinton; Rev. G. Raynor; Rev. F. T. Scott	£20 0 0
J. R. W. Hale	0 5 0
S. Hart	0 2 6
G. Kettle	0 1 0
G. Wells	0 2 6
Anonymous	0 5 0
R. Thorpe	0 10 0
J. S. Murphy	0 5 0
Miss Beach	0 4 0
Rev. J. B. Humphrey	1 1 0
C. J. Price	0 10 0
Captain Hoysham	0 5 0
J. T. Clarke	0 5 0
W. Woodley	0 5 0
W. T. Joyce	0 5 0
W. Greenbridge	0 10 6
P. H. Phillips	0 10 0
Rev. T. B. Garland	0 5 0
Rev. W. S. Walford	0 5 0
W. Bassano	0 10 0
Rev. E. Batrum	0 10 6
J. T. Harveyson	0 5 0
T. Sells	0 5 0
W. Sells	0 5 0
Oxford-shire Association	1 1 0
W. Dehnan	0 5 0
T. B. Blow	0 10 0
Rev. T. B. Blundell	1 0 0
W. Churchill	0 1 0
Amount previously acknowledged	122 1 0

£152 10 0

Beside the above, many of the Members have intimated their willingness to increase their subscription for the current year.

The preceding result is most encouraging; and it is with no slight satisfaction we announce that the whole of the debt which has been incurred has been fully discharged. Our thanks are due to all who have extended a helping hand to the Association in their late emergency. It proves that the Association have won the confidence of all bee-keepers by the work done by them in the past; and it affords encouragement to them in their labours for the future. These labours will be neither few nor slight. The International Health Exhibition at South Kensington must find Apiculture fully represented in all its branches. The

Royal Agricultural Society at Shrewsbury should also find bee-keepers to the front. There will probably be a renewal of the Bligh experiment. Several counties are still to be opened up by the establishment of Associations. The questions of the Honey market, the Central Depot for hive appliances and bee produce, and the Reading-room, will require solution. Everything indicates that the present year will be one of activity, and we trust of progress.

#### CONVERSAZIONE.

On Wednesday, January 16, a conversazione will be held at 109 Jernyn Street, at six o'clock, after the Quarterly Meeting of the county representatives, when a paper by Mr. S. Simmins, Rottingdean, Brighton, will be read on that scourge of the apiary 'Foul Brood.' It is hoped that the members of the Bee-keepers' Association will assemble in large numbers, as no subject of greater importance to all bee-keepers could be selected.

#### HON. SECRETARYSHIP.

A letter has been forwarded to us for publication in the *Journal* from J. P. Jackson, Esq., of Liverpool, broaching the idea of raising a testimonial to the Rev. H. R. Peel, on his resignation of the honorary secretaryship of the Association; but at the special request of Mr. Peel this has not been carried out.

The Rev. H. R. Peel, having retired from the office of Honorary Secretary, has offered himself for election on the Committee. It is requested that all communications should be addressed to J. Huckle, Secretary B.B.K.A., King's Langley, Herts.

Remittances should be made by Postal Order, Post-office Order, or Cheque; Post-office Orders to be made payable at the King's Langley Post Office. Cheques crossed 'Bucks and Oxon Bank.'

#### ANNUAL GENERAL MEETING.

The Annual General Meeting of the members will be held at 105 Jernyn Street, near Piccadilly Circus, on Wednesday, February 20th. Notices of motions for this meeting must be sent to the Secretary on or before Monday, February 14th.

#### BRITISH BEE-KEEPERS' ASSOCIATION.

Since the publication of our last number voting papers for the election of the Committee for 1884 have been issued to each member of the Association. The number of candidates is in excess of any former year. In addition to the retiring members who have served the Association so well in the past, the list contains the names of several gentlemen well known in the bee world. The retiring members of the committee are the Rev. E. Bartram, Hon. and Rev. H. Bligh, Captain Campbell, T. W. Cowan, J. M. Hooker, H. Jonas, Rev. G. Raynor, Rev. F. T. Scott, and D. Stewart. The Rev. T. B. H. Blundell and Mr. H. G.

Morris again solicit the suffrages of the members, and are ready to take a part in the onerous duties of acting on the committee. The new candidates are Mr. J. N. Bowcr, Hon. Secretary of the Warwickshire Association; Mr. A. H. Heath, Hon. Secretary of the Staffordshire Association; the Rev. F. G. Jenyns, Representative of the Hertfordshire Association; the Rev. H. R. Peel, late Hon. Secretary of the Central Society; the Rev. F. S. Selater, Hon. Secretary of the Buckinghamshire Association; the remaining candidates being Captain Bush, W. Martin, Rev. W. E. Medlicott, and C. P. Ogilvie. As the committee consists of only nine members, it is inevitable that the Association must lose the services of several good men, who would gladly give their time and energies for the furtherance of the Society's work. The manner of voting is easily understood. Members have only to mark the names of the candidates for whom they are desirous of voting.

Members are entitled to one vote for each 5s. subscribed; but no member has more than four votes. Example: A subscriber of one pound per annum, or a life member, is entitled to four votes. If the member marks the names of nine candidates, this counts as four votes to each candidate so marked. In case he only marks the name of one candidate, it counts as four votes to that candidate. The same rule applies whether the member be entitled to one, two, three, or four votes. Members are only entitled to vote whose subscriptions are paid for the current year. We venture to hope that a large number of the members will record their votes in the election, thus showing their anxiety for the prosperity of the Association.

The Voting Papers must be returned to the Secretary on or before the 19th inst.

#### A LOWER GRADE OF EXPERTS.

'A Platelayer, Ruckinge, Ashford,' in your last issue, makes a suggestion to the effect that the County Bee-keepers' Associations should hold private examinations of cottagers and farm-labourers at numerous points in their several districts, with a view to granting them certificates as experts; his idea being that county gentlemen, who take an interest in apiculture, would readily give employment to these so-called experts.

He further states that he is aware that the parent Society give certificates to experts who are qualified to give a stump lecture. Allow me to refer him to p. 62 of your issue of June 15th, of last volume of the *Bee Journal*, where he will find the Syllabus of Subjects for Examination of Experts—a list which, so far from prescribing a stump lecture only, embraces the whole science, theoretical and practical, of modern apiculture. The lecture, indeed, occupies merely twenty minutes, out of two long days' examination, and is entirely optional, save the short explanatory lecture given during manipulation. When I state that the candidates include clergymen of the Church of England, Non-conformist ministers, certificated schoolmasters, and



others of the better educated classes, your correspondent will perceive that the requirements are far beyond the powers of simple 'Hodge,' as he designates, I presume, the countryman or agricultural labourer. The examination-papers contain thirty lengthy questions each, and grammatical construction, and especially orthography, are taken into consideration in awarding the marks.

There is no limit to the number of certificated experts in any particular county, hence it appears to me that, instead of creating a lower grade of experts, it will be more advantageous for each county to increase the number of the present grades, and extend its exhibitions and tent-manipulations to every Horticultural or Cottage-garden Show within its own area, in preference to undertaking the expensive and, in all probability, futile attempt to certificate 'Hodge' throughout the United Kingdom.

If 'Hodge' be intelligent, and really fond of his bees, he will, by the plan above suggested, enjoy every opportunity, at the smallest possible expense, of becoming a skilful, practical expert, under the guidance and teaching of really able men; and his own apiary, with its improved produce, will become a better certificate for procuring apicultural employment from his master, and the country squire in general, than any parchment document he might otherwise obtain.—GEORGE RAYNOR, *His High Rectory, Jan. 14th.*

P.S.—By reference to the Syllabus and rules for Examination, it will be seen that the successful candidates are arranged in three classes, or grades. To descend below this scale would seem to me most undesirable.

## BEE-KEEPERS AT HOME.

NO. IV.—THE REV. GEORGE RAYNOR, of HAZLEIGH RECTORY, MALDEN, ESSEX.

(Continued from page 6.)

On Mr. Raynor's return to England, after holding temporary charges in Yorkshire and Worcestershire, we find him in the autumn of 1853 in sole charge of the parish of Tottenham, near Dunstable, Bedfordshire, with an established apiary, consisting chiefly of bar-hives, and an adaptation of Nutt's hive, with one collateral box only, the communication being by an entrance sunk in the floor-board between the boxes, and which appears to have answered its purpose well. The pretty rural village of Tottenham, standing at the foot of lofty downs covered with wild thyme, was noted for the excellence of its honey; and in those early days one of its cottagers possessed an apiary of thirty skeps, which yielded large supplies of honey, taken chiefly in straw supers of from six to twelve pounds each. These were beautifully woven, owing to the skill of the country-folk in the manipulation of straw for the manufacture of 'straw-plait,' to which the children are trained from early childhood. In those days it was impossible to procure attendance at school except by giving up half the day to straw-plaiting; all other work, including the three 'R's,' being termed 'hinderling work'—hence the skill with which the straw skeps were wrought from the peculiarly fine quality of the straw grown in those parts.

So close was their texture, and so great their strength, that a skep was not allowed to pass muster unless it would bear the weight of the heaviest man. To this day Mr. Raynor obtains his skeps from the same locality. Here he worked also skeps on the Grecian pattern, contracted towards the bottom, with comb-bars and straw cover, and in one of these he kept a colony for fifteen years, working supers and supplying fine specimens of comb-honey from the outside bars. This hive is considered to rank next after the bar-frame for general usefulness, and is, indeed, a moveable comb-hive, in which the bees winter remarkably well. He also used the Huber observatory, or leaf-hive, but from the propolis of its close-ended frames, and the consequent irritation of the bees on opening, with the unavoidable crushing in closing it, he soon discarded this hive, and adopted as an observatory the uni-comb-hive with its glass doors, as used by Huber, and improved by Bevan, Golling, and others, and which still remains the best observatory-hive we possess, all points considered.

The *laves et panes* were removed from Bedfordshire to Essex at the close of 1856; a dozen hives of various construction, well ventilated, and carefully packed in road-van for a journey of more than fifty miles, and which safely arrived, without a broken comb, or severely the loss of a bee, at their destination of Kelyedon Hatch, to the sole charge of which Mr. Raynor was now appointed. Here he remained for a period of ten years, during which he was as ardent in his apicultural pursuits as ever, and became a correspondent to the *Journal of Horticulture* and the *Field* newspaper, the only organs of the science at the time in this country. In their columns, amongst other interesting matter, the Stewarson system was fully discussed, and many colonies at Kelyedon were placed in these hives—hives which, although yielding large amounts of honey, did not satisfy the aspirations of a keen observer, as affording but little or no acquaintance with the internal economy of the commonwealth of the honey-bee.

Although the Italian bee had been introduced into England in 1851 the supply was very limited, and it remained in few hands for ten or a dozen years after its introduction. It was not until 1865 that Mr. Raynor had any thought of making trial of the golden-banded bee, when he corresponded with that father of apiculturists, Mr. Carr, of Newton Heath, respecting its merits and demerits, and being favourably impressed with the views of this gentleman, and those of Messrs. Woodbury, Neighbour, and Pettitt, he determined on the first opportunity to give it a full and fair trial. Being on the point of leaving Kelyedon, he was unable at that time to experiment upon the introduction of a new race of bees to his apiary. The singular circumstance of the loss of one year's entire harvest of honey, occurring at Kelyedon, deserves notice here. For some time during the summer of 1860, a remarkably strong scent of onions was noticed when near the hives, and the flavour of honey-comb taken from a hive was found to be equally strong. The cause was not far to seek. Within a mile of the apiary was discovered a quantity of wild garlic in full bloom, with numbers of bees busily at work upon it; a sample of this honey was submitted to Messrs. Neighbour, who pronounced it worthless, and quite unadventable.

Removing to Tonbridge in 1860, some two dozen colonies were placed in an out-house adapted as an apiary at Kelyedon, where they remained the whole of the summer without supervision of any kind, filling spacious supers and not a single stock having given off a swarm.

Then came another transit, the whole being removed to Tonbridge, by van, without loss. And here the wished-for opportunity of Italianising his apiary was afforded to Mr. Raynor. Having paid a visit to Mr. Pettitt's apiary at Dover, he was introduced to some of the most beautiful specimens of Italian queens he ever remembers to have seen, and speedily became possessed

of several, which, with one or two losses, were placed at the head of strong colonies, whose dusky population soon changed to the golden-striped Italians. Several colonies were now transferred from straw skeps to Pettitt's Woodbury bar frame-hive, and the skep all but disappeared from the apiary, displaced by the moveable-comb hive with all its advantages of facility of manipulation and interchangeability of combs.

During his five years' sojourn at Tonbridge, Mr. Raynor continued to make the acquaintance of apianar notabilities, and the proofs of Major Munn's edition of Dr. Bevan's 'Honey Bee' were submitted to him for correction and suggestion. He also carried on a correspondence with Mr. Woodbury, and received from him a considerable number of Italian queens, for experimental introduction, and for other purposes. His plan of introduction, at this time, was chiefly that of Mr. Woodbury, by means of the German pipe-cover cage, and which he still practises, and strongly recommends in his second edition of *Queen Introduction, or the Ligurian Bee*, &c., the only exception being that of stupefying the bees by the fumes of puff-ball, as described by him in the *British Bee Journal* (Vol. I. page 1035), before introducing the alien queen. That history repeats itself is clearly shown from the favourite plan of D. A. Jones, the most prominent apiarist probably of the new world, coinciding entirely with Mr. Raynor's, the anæsthetic used being chloroform instead of puff-ball. By this means Mr. Jones claims to have introduced successfully fifty queens in fifty minutes.

Early in 1870 Mr. Raynor was presented to the Rectory of Hazleleigh, Essex, but, in consequence of a new Rectory-house being required, he obtained a year's grace before going into residence, and it was not until August 1871 that he quitted Tonbridge to return to his old county of Essex.

The site chosen for the Rectory was the apex of a hill, commanding extensive views of the whole of the surrounding country, including the ancient borough of Maldon and the estuary of the Blackwater. The apiary, which had to undergo another removal, was not forgotten in the laying-out of the Rectory grounds, and, although at first the fostering shade of the sheltering tree was sadly missed, the bees now enjoy a most picturesque and protected position, and in good seasons the yield of honey from 30 to 40 hives has been from 10 to 15 cwt., one season's yield alone having produced a nett result of 7½.

On the establishment, by Mr. Abbott, of the *British Bee Journal*, in 1873, Mr. Raynor became a contributor, and his connexion therewith has continued to the present time. On the holding of the first show of the British Bee-keepers' Association—of which he became a member from the first—at the Crystal Palace, Mr. Raynor was an exhibitor and a judge, the first prize of 3*l.* being awarded to him for 'the best exhibition of super-honey from one apiary.'

It was here that the acquaintance of all the prominent bee-keepers of the time was made; that general feeling of friendliness, which obtains amongst all really earnest cultivators of the bee, conducing to the formation of sincere and lasting friendships, not a few of which have, alas! been severed by the hand of death. The Hazleleigh apiary has now become an established institution of the Eastern Counties generally, and numerous are the visits paid to it by all classes interested in the subject during the summer months. Here every known variety of the domesticated honey-bee may be seen, located in almost every kind of modern hive. Three houses, containing an aggregate number of twenty-six hives, and as many more on separate stands—tastefully interspersed with evergreen bushes—bearing supers, sectional, glass, and straw, of varied form and style—queen-railing nuclei, and, indeed, all the appliances of a modern apiary, may be seen here, and explanations and advice are freely given. A hearty

welcome is accorded to all interested in apiculture; and we cannot better conclude this sketch than by wishing its subject many years of health and happiness in the prosecution, amidst the duties of his sacred calling, of his long-loved and cherished pursuit of apiculture.

#### MR. SIMMINS'S ECONOMIC OR BUSINESS HIVE.

There has been so much said about 'cheap' or 'make-shift' hives, that I think it is time to consider whether true economy is really studied by those who advocate and make them. Many such cost in the end more than a good substantial hive made from even timber; and while one is about it, he may just as well have a good article, which can be made from even stuff in less time, with less labour, and very much more credit to himself. Make-shift hives, too, are often unsuited to the best methods of working, and by using them the bee-keeper may soon lose several times the value of a good article. If the price of wood is considered, it will be found that the cost of the material used in my hive as presently described comes to little more than the amount that would have to be paid for old boxes, without the 'tinkering' and loss of time necessary with the latter.

The hive now used in my apiary is the result of much study and practice. I have been endeavouring to obtain that which would give the best results under all conditions, and have produced it with the greatest economy of labour and material that could be represented in a complete but substantial hive. If a hive be made from ordinary 9-in. boards, after planing both edges, the width will be barely 8½ in.; and as the wood will in time shrink quite ¼ in. more, we shall then have the frames resting on the floor-board, which for many reasons is not desirable. Therefore I use 11-in. boards, ripped down to leave 9½ in. for the two sides; and when the edges are planed we have left 9 in., or ½ in. under the frames, which are 8½ in. deep. This ½-in. space will allow for any shrinkage that may occur.

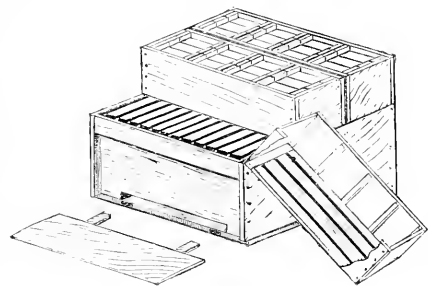

Fig. 1.

I have found ¾-in. material quite thick enough, but should not care to use thinner, or the work would not be rigid. For the body-box, floor, &c., white deal is used, being cheaper and lighter to handle than yellow deal; but for the covers I have found no economy in using anything but the best yellow pine. This wood is less likely to crack or shrink, and though expensive, I can make my covers (fig. 4) cheaper and quicker with that wood than the ordinary cumbersome covers, having super rims, and made of common wood.

The floor-board is made of two pieces 17½ in. long; one 11 in. wide and the other 5 in.; halved together at the joint, and prevented from warping by two strips screwed across underneath. For this purpose the pieces are used which have been cut from the 11-in. boards to

reduce them to the necessary depth for the side walls. The landing-stage is the same length, and  $5\frac{1}{2}$  in. wide, slanting off at 3 in. from the inner edge, and is moveable, being held to the floor-board proper by two tenons or tongues, set 3 in. from either end, each being  $1\frac{1}{2} \times 2$  in., and projecting 2 in.; with a corresponding mortise in the floor-board to receive them. The 3-in. space is left flat, so that the draught-preventer (fig. 2), presently to be described, can be fastened securely there, and when not required, the alighting-board is simply reversed, and the full summer entrance given. I have no porch or entrance-slides to my hives, considering them useless incumbrances, and submit to the draught-preventer only while building up in spring, because actual practice has convinced me that it is invaluable at that time. Bees can put up with any amount of cold if not in the shape of damp or draught; and since using the wind-break, I have been able to build up much faster, and at the same time have had no chilled brood, while many others have suffered from that cause during the disastrous sales that have visited us in the spring of late years. My draught-preventer as now made has 3-in. passages, and gives all the space necessary as an entrance until the bees are strong enough to protect themselves from a sudden change in temperature.

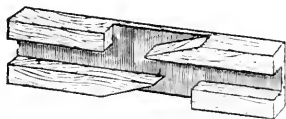

Fig. 2.

A board placed slanting before the entrance has been recommended, but that is not of the slightest use for preventing draught, and though acting as a shade from the sun, it has the disadvantage of destroying the 'site' of the entrance. I have used the 'draught-preventer' extensively, sometimes leaving it on all summer as a test, and never have it blocked with dead bees. In fact, as I now make it, it is practically as good as a plain entrance, and has the great advantage of stopping all draught.

The body-box (fig. 1) has two plain sides  $17\frac{1}{2} \times 9$  in., which are nailed on, and project over the back and front  $\frac{1}{2}$  in.; the latter being  $16 \times 8\frac{1}{2}$  in., the top edge of each being rabbeted out  $\frac{1}{2}$  in. deep to form a narrow ledge on the inner side for the frames to rest on; said runner being  $\frac{1}{2}$  in. lower than the sides to take the thickness of the lugs or ears of the frames. The pieces cut off to reduce the back and front boards to the right width then come in to fill out the space left above them. Thus we have a body-box square outside ( $17\frac{1}{2} \times 17\frac{1}{2}$ ), but inside  $14\frac{1}{2} \times 16$  in., taking eleven frames for ordinary use. In spring, however, I build up to twelve frames in that space (16 in.), and reduce to nine before placing on supers, crowding the bees into the sections at once.

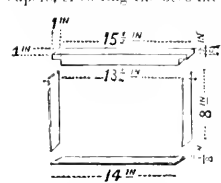

Fig. 3.

bottom rail is  $\frac{1}{2}$  in. thick, all one inch wide.

I use no distance-pins, broad, or under-shoulders as guides, as I can manipulate much quicker without them, and would not use them again for any consideration. The

illustration will show the form and dimensions of the frame better than can be described; and let me here suggest that the Association have some similar standing illustration of their 'Standard frame' in the advertising (or other) columns of the *British Bee Journal*. I am of the opinion that this would as much as anything tend towards the universal adoption of the Association frame.

The long top bar (17 in.) now made to Standard frames not only looks but is awkward, and necessitates a waste of material in making hives to accommodate it. Presumably it is so made to be altered to, or to fit where wide-shouldered frames are in use. The originators of the idea seem to have ignored the fact that the more economic shorter top bar will go in anywhere, while the long bar must be shortened before it will fit in with those of the more sensible length. Those who must have guides can use nothing better than wire nails or staples, and before adopting broad shoulders will do well to remember that the latter are subject to every change in the weather; shrinking and leaving space for propolis in summer, and expanding to such an extent at other times as to be extremely difficult to remove or replace, and after long use are so propolised as to greatly impede manipulation.

There are two dummies for use with each hive. A frame of .in. stuff,  $14 \times 8\frac{1}{2}$  in., is first made,  $1\frac{1}{2}$  in. wide. A board of suitable thickness is then tacked inside the rim, flush to one side, giving it a neat appearance. Thus when the nine frames are used in supering, the hive is reduced to the correct space by inserting the two dummies—one at either end. For small colonies, or for wintering, a dummy is kept close to one side, while the other is brought up towards it, according to the number of combs in use. I know I am here trespassing on present theories, but I have given tight, and partly tight-fitting dummies a lengthened trial, and am glad to come back to one that is so easily moved, and answers every purpose of my own management. Even when used, fitting tight to the sides, it is bad policy to have them close down to the floor-board, as should any stray bees get behind their doom is sealed, as they cannot regain the cluster. For various other reasons I have often found it desirable to have a space under the division-board. Of course when used for dividing colonies, the board must fit close all round, though I must say I find I can work independent colonies to much greater advantage.

The roof next claims our attention (fig. 4). As will

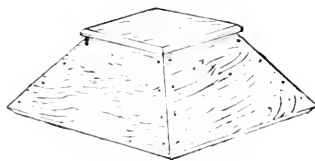

Fig. 4.

be seen, it is very simple in construction, takes little wood, fits almost any hive, and throws off the water better than any cover I have been able to make, and though comparatively light its shape makes it almost impossible for wind to blow it off. It has stood the severest gales without moving, but to make assurance doubly sure, a kiln brick can be fastened at the top of the roof, inside, with two little rafters screwed across.

For covering the square hive, each side is cut out exactly the same, from 11-inch pine, in the manner shown by the accompanying sketch, and there is, as will be noticed, barely any waste of material (Fig. 5).

To make the corners fit true, for  $\frac{1}{2}$ -in. boards, each edge is gauged at  $\frac{1}{2}$ -in. on the under side, and planed off, slanting to that. For greater accuracy I have a gauge-

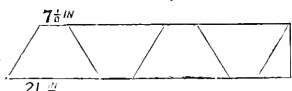

Fig. 5.

to lay the boards against, at the proper angle, on my circular saw bench. The narrow (top) end of each side should have a shallow piece  $\frac{1}{2}$ -in. wide cut out at the centre for ventilation. The top board is 9 inches square, and having its edges chamfered off is set on the centre and held secure by screws from underneath. Besides being painted well outside, the covers are given at least two coats, three inches up all round, inside.

It will be observed that the customary plinths around the joints are dispensed with. This is one point I have always aimed at. The shape of the cover does away with the necessity of them where it fits over the body, and there are none attached to the super crates, simply because they are never on long enough to need any; of course they are only in use during the summer months, and I have in no single instance found the wet enter the hive while they were on. As to having plinths to protect the floor-board, I never could see the use of having them on three sides, while the fourth (front) had none, where the water could soak under without hindrance. Again, wherever I have seen them they have not been painted *inside*, thus permitting any wet, after reaching the bottom edge, to be drawn up by the bare wood, and thence to the quilt. Plinths do not by any means add to the appearance of the hive, and besides, causing extra labour and expense; I find that, however well fastened in the first place, they are often getting out of order, warping slightly from the main walls, and water soaks between. The bee-keeper need fear little from dampness if the floor-board is well painted, if not all over, at least three inches in all round, painting also the bottom edge of the hive. It is the bare wood just inside that attracts the water, and a little more paint properly applied will enable us to do away with such useless incumbrances. For simplicity in management, I say, therefore, have neither bevelled, rabbeted, nor plinth-covered joints, where hives or covers rest on each other, or the floor-board. Our desideratum should be a hive, permitting any number of them or their crates, to be readily piled, one above the other, to an unlimited extent.

Where one intends to make a number of hives, a saw-bench is a necessity, and if not too expensive, will soon pay for itself. If properly constructed, it should be made to cut all the boards from the plank, do all the grooving, and rabbeting throughout the hive; and, consequently do all its work to proper gauge.

The reader will probably smile when I state that the whole of my work is done on a small bench fitted up by myself, over, and driven by, the power obtained by turning an American grindstone. The bench, which can be readily lifted off, when the stone is required for grinding, has a shelf arranged to carry the sawdust away from the bearings.

#### THE SECTION AND CRATES.

I make all my own sections, and they cost me less than the American 'one-piece.' The illustration (Fig. 6) gives the section fitted together, being for 1-lb., and is  $4\frac{1}{2} \times 4\frac{1}{2}$  inches. The sides are each  $\frac{3}{4}$  inches long by  $\frac{1}{2}$  inches wide, cut from  $11 \times \frac{1}{2}$  in. stuff into pieces of that length first being planed on one side. These pieces ( $11 \times \frac{1}{2}$  inches) are next grooved half-through on one side at  $\frac{1}{4}$  inch from each end, for receiving the top and bottom rails, which are of the thickness of the width of the groove, so that they may fit tight. By



Fig. 6.

arranging a saw of suitable thickness, each board cuts into exactly six pieces. The bottom rail is  $1\frac{1}{2}$  inches wide, and  $1\frac{1}{2}$  inches long. The top is composed of two pieces, each being barely half the width of the bottom rail, but of the same length. The upper rail is made in this manner for the insertion of foundation between; and I find this the neatest, quickest, and most accurate way of fastening the starters; the two halves being simply pressed together on to the foundation, holding it securely in a perpendicular position. I have neither made nor used any other sections for several years, and all who have seen them have been greatly pleased with their excellent appearance, and, what is more, they are preferred to any other in the market.

Though in several pieces, the section is more rapidly put together than the 'one-piece,' and there are no joints to nail or glue, as with that section, which often breaks at the corners.

I use no such impediments as separators or blocking arrangements. For straight combs I depend upon the following conditions being present:—A *narrow* section; the foundation hangs exactly *perpendicular* from the centre of the section; while supering, the hive is set upright. I use only three sections across the crate, and keep all partly worked sections together.

My crates (Fig. 1) are not simply racks, but are made of  $\frac{1}{2}$  in. stuff with sides the same depth as the section. Three crates are used on top of the hive, each holding four rows of three sections. Thus there are *thirty-six* sections on at one time, arranged in three crates side by side, either of which can be removed independently of the other, giving the best possible arrangement for working the supers on the correct principle of bringing all partly worked sections to the *centre* according as full ones are taken out. Of course if the thirty-six do not give the colony sufficient space, other sets of crates can be placed above to an unlimited extent, though, if properly worked, the three will often be sufficient. The crates being the full depth of the sections, does away with the necessity of a super rim to the cover of the hive, making the whole arrangement more compact, simple and less expensive.

The bottom of the crate is composed of four laths, with another  $\frac{1}{2}$  in. wide at the ends to hold them together. The centre two are  $1\frac{1}{2}$  in. wide, while those at the sides are only  $\frac{1}{2}$  in. wide, giving three spaces of nearly  $\frac{3}{4}$  in. between them. The laths are cut from  $\frac{3}{4}$  in. wood, and planed on the under side, and when fastened together, they are secured inside the rim, flush with the bottom of the crate.

These are set *close* on the top bars of the brood frames with the slats at *right angles* to them. There is then no space for combs to be built above the frame-bars, which with other crates or racks so impedes manipulation. Of course slight propolis takes place, but I have found this far preferable to having pieces of comb built in the usual  $\frac{1}{2}$ -in. space above the bars. If I want to examine the brood frames while working the supers, I take off each crate just as easily as I can remove a frame; they are then stood down at the side on end, leaning against the hive, and when I am ready are replaced with as little trouble without crushing a bee.

My sections give their own bee space under and above, there are therefore no laths required for raising either them or the crate. *By no means* should the slats at bottom of the crate be placed on the hive *parallel* to the bars of the frames, or it can not be removed without lifting the frames under it. Neither would it be possible to use a full-size crate with the bars crossed as with the narrow crates, or the whole of the frames would lift when the attempt was made to remove it. As before stated the sections are  $1\frac{1}{2}$  in. wide. The three therefore occupy a space of  $5\frac{1}{2}$  in.; but if this were to be the width of the crate, it is evident that the middle section would be much heavier than the two outside ones, each of which

would have one side to the wall of the crate. To correct this, and to obtain combs as even as possible, strips  $\frac{1}{2}$  in. thick, are tacked on the inside of the crates where the sections meet (Fig. 1), making the width of the crate  $5\frac{1}{2}$  in. (inside). The sections fit nearly tight, and I have never yet found the necessity of wasting space on wedging arrangements. The length of the crate, inside, is of course 18 in., taking four  $4\frac{1}{2}$  in. sections. The strips tacked to the side are sawn from the  $\frac{1}{2}$ -in. pieces taken from the floor-boards where halved together, and other similar pieces, which otherwise would be useless. They are rapidly tacked in place by the aid of a board 18 in. (nearly) long, having slots cut on one edge, at the proper distance, to run over and guide the several pieces.

For the purpose of observation during summer, the top and bottom rails are of glass; and nothing can be more interesting, especially to visitors, who like to see the bees actually at work. No other arrangement will permit such a thorough insight into the ways adopted by the bees in building their combs, and storing the honey. With their feet to the glass, the little scales of wax can be readily perceived, as they are being moulded into shape with such wonderful precision. The honey-laden bee is also to be seen placing its store in the delicately formed cell, with its little red tongue systematically moistening the side walls to make the honey adhere, while at the same time it is gradually relieving itself of its load.

For this purpose, the top rail (halved to receive foundation) should be of equal width with the sides. With glass the cost will be considerably more than the American section.

Many minor particulars have of necessity been omitted, but I shall be happy to supply any further information on receipt of stamped envelope.—SAMUEL SIMMS, *Rollingdean, Brighton.*

## RUDIMENTS OF BEE-KEEPING.

(Continued from page 7.)

It is of the greatest importance that all feeding with liquid food should cease early enough in the autumn to enable the bees to seal it over. Otherwise, the watery syrup may cause disease in the hive. If additional store is required late in the autumn, or during the winter, candy should be used. Sufficient autumn feeding is of the utmost importance, for the loss of most of the stocks which die during the winter is occasioned by sheer starvation. It is so easy to ascertain how much food a hive contains, and it is so easy to supply any deficiency, that starvation should not occur, and bee-keepers who allow their bees to starve are as culpably negligent as they would be if they neglected to supply their domestic animals with sufficient food. As a precaution, a cake of candy, either inside the hive in a frame, or above it, can be used. *Modern Bee-keeping* tells of the way to make such candy. Never feed with syrup or candy in the entrance or on the floor-board inside, for, if you do, robbing will be encouraged; and, in winter, your bees must also run the risk of being chilled in getting to their food.

There is a great difference in the winter consumption of food in different hives, and it is impossible to lay down any hard-and-fast rules as to the amount required. However, no risk should be run. Bee-keepers generally consider that a hive containing 20 lbs. of stores need cause no anxiety. Whilst feeding bees, and throughout the winter, the entrance of the hive should be made smaller. In the case of old-fashioned skeps with high semi-circular entrances, this can be done by a well-fitting plug of wood with a hole in it three-eighths inch high, and broad enough to allow two bees abreast to pass through. If your skep has a wooden band on its lower edge,—as it should have,—you will then be able to narrow the low entrance cut in the wood much in the same way as the entrances of frame-hives are con-

tracted by wooden slides. Special care must be taken to thoroughly confine the heat in the hive. In skeps, the hole in the top should be securely plugged with some old piece of rag. In moveable-comb hives a sufficient thickness of quilts must be used to check the radiation of heat. Chaff-cushions or cork-dust are very useful for the same purpose. The use of winter passages either above the frames (between two slips of wood placed under the quilt), or passages cut in the combs themselves, is very desirable to enable the bees to move safely from one part of the hive to another as occasion requires.

This done, you should keep your hive carefully shaded from the sunshine, and at intervals satisfy yourself that the entrance is not blocked by an accumulation of *Bees* which can be done by using a wire rake. And now, like a dormouse, the less your bees are disturbed for a time the better. Keep a careful look-out to see that no mouse establishes himself inside your hive, or a slug. In fact try and guard against all enemies, —wind, damp, draughts, mice, slugs, moth. Now, too, is the right time to prepare for the early spring. Too often necessities are not thought of until required, and then delay and consequent loss of valuable honey follow. Let the beginner ascertain what he is likely to require at the commencement of the season,—supers, sections, foundation, artificial pollen (pea-flour), additional hives, &c. These should all be in readiness for use by the time the season commences. Old appliances also should be thoroughly overhauled and cleaned, and salicylic acid solution freely sprinkled over everything connected with the apiary with a spray diffuser.—E. S. SLATER.

## ASSOCIATIONS.

### COUNTY ASSOCIATIONS.

About this time of the year the annual meetings of the County Associations are held, when the balance-sheets are presented, and reports of the preceding year are read. We shall be pleased to have condensed reports from the secretaries of the respective Associations, and to the extent of our ability give insertion to them.

#### BUCKINGHAMSHIRE BEE-KEEPERS' ASSOCIATION.

We are informed that the General Meeting of the Buckinghamshire Bee-keepers' Association will be held at Aylesbury on the 17th inst.

#### CORNWALL BEE-KEEPERS' ASSOCIATION.

The Annual Meeting of Members will be held at the Town Hall, Truro, on Wednesday, January 2nd inst., at 3 p.m.

#### DORSETSHIRE BEE-KEEPERS' ASSOCIATION.

The Report and balance-sheet of the Dorsetshire Association for 1883 are to hand. It is satisfactory to note an increase of 75 new Members, the total number being 177. We also notice with much satisfaction that the list includes the names of 57 *bona fide* cottagers and labourers.

We regret to observe that the balance-sheet shows a deficiency of upwards of 14*l.*; the cause is clear: several shows were held at which prizes were awarded to the amount of 30*l.*, the expenses of these shows amounting to an additional 20*l.* We venture to suggest to our

Dorset friends the advisability of their offering a certain amount in prizes for honey, &c., at various Horticultural Shows. The small amount of space required for this purpose would be gladly provided by the local Society, and the County Bee-keepers' Association would thus be relieved of a considerable item of expense.

A small charge for admission to the Bee Tent, which should be erected in the Show Ground, will generally bring a small addition to the funds.

#### STAFFORDSHIRE COUNTY BEE-KEEPERS' ASSOCIATION.

This Association is to be congratulated on its first year's work. The annual meeting was held on the 2nd of January at Stafford—Mr. Thos. Salt, M.P., in the chair, when forty-eight members were present. From the report of the hon. secretary, it was shown that there were in the Association upwards of 220 members, and although there was shown to be a deficit in the accounts to the extent of 11*l.*, the treasurer explained that the amount was easily covered by the assets, and gave promise that within another year the expenditure would be covered by the income. The Bee Tent belonging to the County Association has been hard at work; and the expert, Mr. A. W. Rollins, has given great satisfaction in attendance on it. Mr. Rollins paid a visit, during twenty-seven days in the autumn, to more than one hundred members, and is to have another tour in the ensuing spring. The old committee were re-elected for the ensuing year, with some addition; and Mr. A. H. Heath was re-elected hon. secretary and treasurer.

#### LEICESTERSHIRE BEE-KEEPERS' ASSOCIATION.

This Association have forwarded their second annual report. The committee feel that they may fairly congratulate the members on the success of the Association during the past year. There has been an increase of members, and the interest taken by all classes in the work of the Association shows no abatement. Shows have been held during the year at Malton and Lutterworth. The financial position of the Society is also good. The vacant vice-presidency, caused by the death of Major-General Burnaby, M.P., has been taken up by his successor, Major Montague Curzon, M.P.

#### KENT ASSOCIATION.

This Association held its Annual Meeting on Wednesday, January 9th, at the rooms of the Royal Society for Prevention of Cruelty to Animals at Jermy Street, Samuel Morley, M.P., in the chair.

#### AMONGST THE SWISS BEE-KEEPERS.

##### No. V.

The day was bright when I took the train from Montreux about eight o'clock one morning for a three-hour's journey to Yvon, to pay my promised visit to M. Ed. Bertrand. The railway keeps along the shore of the beautiful Lake Lemman the whole way, passing amidst the vine-covered slopes which rise from the shore towards the Jura mountains to the north, and forming a strong contrast to the abrupt, rocky precipices of Savoy on the opposite side. Picturesque villages and thriving towns are passed on the way, as well as many spots of historical interest; but space will not allow me to enlarge on these, and I would advise all those who take an interest in beautiful scenery and antique buildings to pay Switzerland a visit. The buildings in many towns are found unchanged since a very early period, and the

Swiss have a respect for antiquity which we in England should consider decidedly aristocratic. Passing through Vevey, about four miles to the right stands the Castle of Blonay, which has belonged to the same family for 700 years, and which I mention because its present proprietor, M. Henri de Blonay, is an ardent bee-keeper, and by his invitation we spent an agreeable afternoon at the castle discussing bees. M. de Blonay was one of the judges at the Zurich Exhibition, and takes an active interest in the *Société Romande d'Apiculture*, as a member of the committee. His bees are kept at his town residence at Lausanne, but it is his intention to establish an apiary here, the sloping grounds exposed to the south, and well sheltered from the cold north winds, being admirably suited for this purpose.

In contemplating and admiring the scenery the time passed quickly, and before I had time to tire of the journey the train stopped at Yvon, where my host was waiting to welcome me. A quarter of an hour's drive brought us to his residence, charmingly situated on the borders of the lake opposite to the gulf of Thonon, with the snowy peak of Mont Blanc plainly visible peering over the heads of all the other mountains, and presenting a scene of sublime grandeur impossible to describe. It was arranged that after lunch we should go to see the apiary at Allévays, and in the meantime I was introduced to Madame Bertrand, whom I found in sympathy with her husband on the subject of bees, and encouraging him in his work of spreading a knowledge of bee-keeping in the country. An inspection of the apiary here was reserved until the next day, so we walked in the garden, and admired the view and the flowers. My host, in addition to being an ardent bee-keeper, was also an excellent botanist, and the garden was full of interesting plants. At every turn of the winding paths one came upon something to arrest one's attention; here, amongst some stones, the different varieties of cyclamen; a little further various primulas and Alpine plants, amongst which a natural stream trickled its crystal drops, moistening their leaves, and glistening like diamonds in the sun. Well-known bee-flowers were seen in different spots, as well as many not so well known, and some said to be good honey-yielding plants in America, but as we saw in Scotland 'not proven' yet here, but whose good or bad qualities were before long determined by M. Bertrand's persevering observations. It frequently happens that if a bee is observed on a particular flower, it is at once set down as a good one for bees, and in this manner a number of flowers are included in our list of honey-yielding plants, which have no right to be there. I was particularly struck as to the necessity of a careful observation by the following account of a plant (*Eryngium planum*), of which there was a large patch growing in a bed close to the lake. It was said that this plant was a rich honey-yielding plant, and in 1851 M. Bertrand procured some plants, and commenced its cultivation to determine its qualities with certainty. The plant is a perennial of easy cultivation, attains a height of from 3 to 5 feet, and has from 15 to 25 large, hazel-like flowers of a light blue tint. The plant blooms in July, and every flower is literally covered with bees from early morning until late in the evening; frequently as many as twelve to fifteen bees being counted on one flower. Here then was a flower which an ordinary observer would put down as a good honey plant, and would probably write off immediately to the *Bee Journal*, giving the supposed quantity of honey each flower contained, and by an intricate and ingenious mathematical calculation would tell us that by planting a certain number of acres so many thousand stocks of bees could be kept, and at least so many hundred pounds income could be obtained. M. Bertrand is, however, not an ordinary observer, and does not rush at such hasty conclusions, but is content to go the slower but surer way, of systematic observations

extended over a considerable period. It is only such observations that are of any value, and it is not astonishing to find that M. Bertrand would not commit himself as to the value of this flower as a honey-yielding plant. He had cultivated it for three years, gradually increasing the quantity of plants, and his conclusion now is that it is not a good honey-yielding plant at all, and that previous observers had been deceived as to its quality. There was a long border, with about 300 plants that had flowered abundantly, and the thousands of heads of bloom produced by them had been literally covered with bees from morning till night, without making any difference to the stores in the hive. In fact, after a bee had walked over the whole head of blossom, and had dipped its tongue into every separate nectar-tube, it took a turn upon a neighbouring one and amused itself there in the same manner. A bee was marked and was attentively watched, and after it had remained on the same flower for fifty minutes, it passed on to the next, where it was watched for another twenty-five minutes. Wearied by such constant watching Madame Bertrand took her turn to watch, and came to a conclusion which brought forth the appropriate remark that 'this flower is the public-house of the bees; they amuse themselves there, forget themselves, and return home in the evening with empty pockets.' After three years' experiment, M. Bertrand has decided not to cultivate *Lycium plum* any more, although it was a great favourite with the bees. I think a great many others, said to be good honey flowers, would have to be excluded from our lists if they were subjected to similar careful observations.

Even bee-keepers require refreshment, so after partaking of lunch we started for a drive to the apiary of Allveys, which I was very anxious to see. Allveys is situated at a height of 2112 feet, and is distant about six miles from Yvon, on the road to St. Geroges on the Jura mountains. The drive was very picturesque, and as we rose higher and higher, in time parks and then another of the Mont Blanc range came in view. On our arrival at Allveys, we were met by two English gentlemen who had been attracted thither by seeing the view of the apiary which appeared some time since in the *British Bee Journal*. This apiary, as will be seen by referring to the accompanying picture, is situated on the borders of the forest, and enclosed in the American style. The hives are detached, each being on its own stand, the floor-boards close to the ground, similar to the hives used by me. They are well sheltered from the winds by the forest which extends on three sides. The hives are about six feet apart, in rows, the distance between each row being about ten feet. In front of the hives, bees and there are planted plants which serve as guides to the bees to mark their routes. In the centre of the apiary is a round shed, which is used for manipulation, and a sitting and extracting room. It contains frames, a comb for combing, and a can on the right side is a bed which has been useful to it, when he has been kept late at work with his bees.

From the windows there is a splendid panorama of Lake Lemano and the Alps. These windows are of peculiar construction, being made to revolve on pivots at the top and bottom, so that by merely turning them any bees that had got inside the shed and flown on the glass, could be turned out without any difficulty. A wide path divides the apiary, Laysons hives being on the left, and Dadant hives on the right, so that by working the two systems together a comparison might be made; there being about fifty hives in the enclosure. In front of the apiary are small hives destined to attract the swarms, and borders containing experimental plantations of honey-yielding plants, such as, seraphim, yellow and white melilot, honey phacelia, adonis clover, and others.

This is a good neighbourhood for the bees, for in

the spring they find pollen on the willows, maples, nuts, and coltsfoot, and honey on the maples and wild cherry trees; later, on the cultivated espartet, wild sage, and the flowers of the pastures. After the grass is mown, there are the lime-trees, asphodels, wild thyme, golden rod, astrantia, and others. This apiary is one of the few

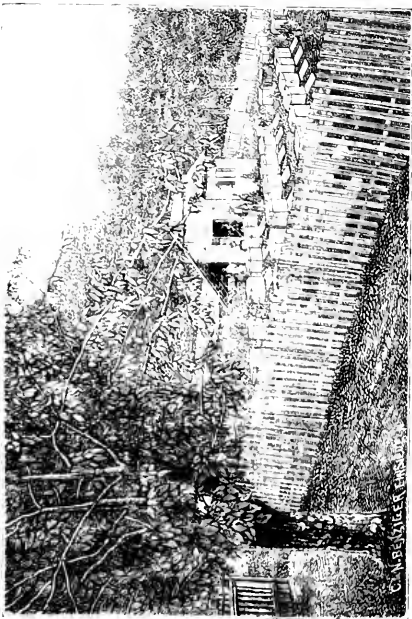

any other place, and certainly not before, it is, however, a then highly practical as well as scientific apiary.

M. Bertrand is the editor of the *Revue d'Apiculture pour la Suisse Romande*, which is, without exception, the best and most progressive journal in the French language, devoted to modern bee-keeping in movable-comb hives. Being such a master and authority, it was natural to expect that his apiary would be worth visiting, nor was I disappointed, for here was really a model apiary in every sense of the word; perfect order reigned everywhere, there was a plan for everything, and everything was in its place.

We proceeded to examine some of the hives, and found them well stocked with bees, and remarkably strong.

M. Bertrand has a valuable and able assistant in the person of M. C. Anderson, who is a schoolmaster at St. Geroges, three-quarters of an hour's walk above Allveys, who, in addition to looking after his own bees, undertook to assist M. Bertrand at a time when they were stricken by foul-brood, and when constant supervision was necessary to stamp out the disease. M. Bertrand's residence being at too great a distance from Allveys to give the bees the necessary attention. As the subject of foul brood was one of particular interest to me, having some years ago had to battle with this disease myself, and knowing that it was only by perseverance and great care that I got my bees cured of it, I was anxious to know how M. Bertrand had proceeded,

When I cured my bees, fumigation with salicylic acid according to 'Hilbert's' method was not known, and it was much more trouble than now. Experiments made on foul-broody hives during the last two years, however, convinced me that fumigation, if properly done, was the simpler process. I was not satisfied with my way of fumigating, therefore was curious to see how M. Bertrand acted; and his method is so simple that, for the benefit of those who have foul brood, I will give a description of it, and in doing so will give the French weights so that no mistake should be made. M. Bertrand told me that since the establishment of the apiary he had had foul brood in some of his hives, these at first he burned, but being induced to try to cure them he persevered and never allowed the disease to get to the worst stage, when a cure would be more difficult. The hives were constantly examined, and if the slightest trace of dead brood was detected they were at once operated upon. Most of the hives in the apiary were now perfectly healthy: there was one, however, that had only recently been cured, it is the one standing just behind the gentleman in the wide-awake hat in the engraving, and M. Bertrand and M. Auberson proceeded to operate upon this one in my presence. For fumigating he has had constructed a lamp, which is cylindrical in form,  $6\frac{1}{2}$  ins. diameter, and with an elbow at the top, ending in an opening 5 ins. by  $1\frac{1}{4}$  in. The total height of lamp with elbow being 11 ins. Beside the cylinder is placed a spirit-lamp and above this is a small tin dish about  $3\frac{1}{2}$  ins. above the wick of the lamp. The hive is not removed from its stand, but is raised up at the back off its floor-board by means of blocks of wood, and wedges are inserted at the sides, so that all the space is closed except enough to admit the nozzle of the fumigator. One gramme of salicylic acid is placed in the dish and the flame regulated so that the acid is gently evaporated. Too much flame would cause it to boil over and waste, not enough would not even melt it, so the right amount can be found out by experiment. The nozzle of the fumigator in operation is now inserted in the opening at the bottom and the corners of the quilt turned up so as to allow the vapour of the acid to circulate freely. A few minutes after the acid had all evaporated the hive was examined and the bees did not seem to be in the least inconvenienced by the fumigation. M. Bertrand said that neither brood nor worker bees were hurt, but he was not sure whether or not the queens suffered sometimes as he had lost some. Hilbert says that each hive should be fumigated every six days, four fumigations being sufficient: but M. Bertrand has continued longer so as to be certain of a cure. The operations should be performed in the morning or in the evening when all the bees are at home. Besides the fumigations the entrance, alighting-board, and the ground round hive, and any portion not reached by the vapour, should be washed with a solution of salicylic acid. This is done with an ordinary syringe. The foul-broody colonies receive every other evening one-sixth of a litre of syrup containing 30 to 50 drops of Hilbert's solution No. 1 (8 grammes or cubic centimetres of pure alcohol to 1 gramme of salicylic acid).

A foul-broody hive should be fumigated previous to its being opened, and all diseased brood cut out and thrown away, as few frames left as the bees can conveniently occupy, and if possible the bees should be forced to build new combs. All the hives in the apiary should be fed, at least once a-week with a syrup containing acid while the disease lasts. After this treatment M. Bertrand found that at about the end of six weeks all trace of the disease had disappeared, and the convalescent colonies gave a good harvest of honey. I was glad to see that in all his operations M. Bertrand took the same precautions I have always insisted upon and to the neglect of which so many have failed to cure their hives. After a hive had been examined everything used as well as the hands were washed in water containing 50 drops of solution

No. 1 in 50 grammes of tepid rain water. A special dress made of linen, which can be easily washed, is used in operating; and the great care taken is shown by the fact that M. Auberson, although constantly manipulating amongst the diseased stocks, had not introduced the disease into his own apiary. These operations are very simple, but not one of the precautions taken can be dispensed with. I prefer to scald hives that contained foul brood, and I have my hives constructed with a view to this; but M. Bertrand pointed out that it would be very inconvenient to do so with such large hives as the Layens, and I also prefer to give my bees salicylic acid in their food whenever they have any. It is now several years since I cured my bees of foul brood, but they have always been fed on syrup containing salicylic acid in the proportions set forth in the *British Bee-keeper's Guide Book*, and, although situated in an infected area, I attribute the absence of disease in my apiary to the constant use of salicylic acid in the food.

I have known many persons who had foul brood who would carry out most of the instructions, and yet would fail in every case from neglecting some precaution. For instance, I remember being called in to see a foul-broody hive on one occasion, and the first thing I saw was the smoker on one of the hives—this had been left there after examining the hive—and had not been disinfected, and was there ready to spread the disease. The bee-keeper had taken great care in getting the proper solution, but failed to effect a cure because he neglected to disinfect all his utensils. I could mention a number of similar cases, and I am persuaded that in the majority of cases it is the fault of the bee-keeper if a speedy cure is not effected. Many others who have followed M. Bertrand's instructions in the *Bulletin d'Apiculture* have been equally successful, and it gave me very great pleasure to have the opportunity of seeing his model apiary. I did not mention that in the shed there is a cupboard in which all the frames containing combs are hung, and these are all fumigated before being used again. The afternoon spent at Allévays was both pleasant and instructive; and after parting with M. Auberson, we drove back to Nyon, and reached home as it was getting dark. After dinner we continued our conversation on bees and bee-keeping until far into the night, and reluctantly retired to bed, having spent a most agreeable day.—TITUS, WM. COWAN.

## Correspondence.

All Correspondents forwarding Letters for insertion in the Journal, Reports of Associations, Shows, Meetings, Etc., from the Hives, queries, &c., are requested to direct their communications to 'The Editor of the "British Bee Journal," c/o Messrs. Stearns, Wray & Sons, Tower Street, Upper St. Martin's Lane, W.C.'

### TWIN HIVE.

I beg to offer you my best wishes on the commencement of a New Year and a new volume. May it prove a happy and prosperous year to you, sir, and to the *Journal*, and to the bee-keepers everywhere; and if the new 'tome' contain as many and as practical instructions as those that have gone before, there is not the slightest doubt but English bee-keepers will be in the vanguard of the army of advanced bee-culture.

Having reached the first month of 1884, it is time to overhaul the stock of hives and appliances, and make up one's mind as to the extent of the increase we intend making in our apiaries; and if our means allow us to purchase our hives, &c., ready for use, our orders should soon be given, so that makers may know what style and quantity to produce, and so prevent delay and disappointment by and-have, when orders are given, and expected to be executed, per return, if not of post, by next train;



and to those who have a liking for carpentry, and make their own hives and appliances, now is the time to set about the work, get it well in hand ere the busy season comes, when one's attention is required in the out-door duties of the apiary.

I enclose a rough sketch of a twin-hive, of which pattern I have three in my apiary, containing six

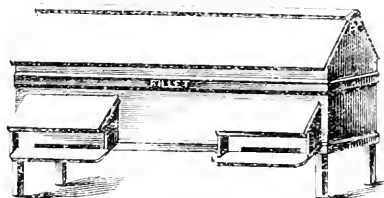

colonies of bees at the present time, packed with only thin  $\frac{1}{2}$  inch division-board between the two colonies in each hive, so that they may cluster as near together as possible for mutual warmth. I have made my entrances both on the side near the ends, with good projecting porches, forming a good shelter from the wind, and also from rain or snow; they open with hinges (doors) over each porch, and the cover when turned up makes a good shelf on which to put anything while manipulating. I find they answer very well, and are, to all intents and purposes, equal to two single hives, and can be made at one-third less cost than two single hives, a considerable item in a large apiary. WOODBRIGHT.

#### CENTRAL SHOW-ROOM AND READING-ROOM.

... I am fond of carpentering, so I make my own hives, and a few other things, but some things I can't make, and others give me more trouble than I care for. When I happen to be in town I find it some little undertaking to go down to Abbotts' and carry all my things back with me, nor do I like to give him the trouble to show me things that perhaps I do not care to have after seeing them, besides, possibly, both he and his son are out. The only bee-shop I know in London is Neighbour's. If you want a well-known thing, and he happens to have it, all very well, but it is hardly the plan to look over a lot of things deliberately.

Now it has often occurred to me that it would be very nice if the Association had a show-room of their own—a sort of permanent exhibition, where everything connected with bee-keeping is sold. It would be a visible and tangible proof of its existence, and very much help to hold it together, and enlarge it. I should not often go to town without going there to refresh my memory, and see if there was anything I could make use of, and I suppose others are pretty much like myself. The library might be kept there, and would be a considerable attraction.

It need not cause jealousy to dealers, they could send their goods, of course paying a percentage. It might suit a small tradesman doing business in a central part, and having a large room at his disposal. Of course he must be up to the mark, and keep himself well posted up. I can see no insurmountable difficulty, and I think it would pay very well if properly managed. A WORKING BEE.

[The idea of an exhibition of bee-hives and appliances is most desirable, but not quite as proposed in the above letter. A commission on sale would almost certainly provoke jealousy among rival dealers; but an exhibition open to all at a moderate rent, where each article should

bear the maker's name, and address, and selling price, with no profit on sale to *any one in connection with the exhibition*, would be useful to every one. This in connexion with a reading-room and honey depot is what Mr. D. Stewart has long been seeking support for, and it is hoped he will bring the proposal again before the general meeting.]

#### EXPERIENCE OF AN AMATEUR.

Transferring is generally recommended to be done in the autumn, but I prefer the spring; in fact, I have always succeeded at the latter time, but failed during autumn when robbing is so likely to take place, and should the weather become wet the bees cannot prepare properly for the winter. Whereas in the spring robbing is not at all likely to take place, and if done when honey is to be had, no feeding is required. For example: on 16th May, 1883, I drove a stock of bees from a skep into (20 × 14) bar hive, my own make, tied combs with brood from skep into three frames, and gave three frames of foundation; on 18th May, took away tapes, combs all well fastened up, gave one more frame of foundation; bees strong, and at intervals of a few days gave bees as required, and on 29th May, bees were working in sections at back and on top; the following month these bees swarmed, besides giving me several pounds of honey.

In regard to ripe honey, instead of the expensive machine for ripening honey by running it over hot-water pipes, I propose having a spirit-lamp under a large can which will hold fifty or sixty pounds of honey, and under over the top, so that the honey will evaporate in the same way, only of course take a somewhat longer time. E. T. C.

#### SYRIAN BEES.

'W.' asks me a number of questions regarding these bees, which I answer: 1st. 'Are pure Syrians, upon the whole, when not smoked, as gentle and good-tempered as pure Ligurians?' Answer, Yes, and more so, if you only keep off stinging them with smoke or jarring their combs or hives, and I might add crushing them, but they do not seem to resent this barbarism as much as the above. Of course, if you go about your bees smoking a pipe, or are even in the habit of smoking, you had better let the pure ones alone, or you will come to the same conclusion as the 'well-known bee-master' quoted, that is, if I guess rightly who 'W.' means, I have never been able to make or induce these bees to gorge themselves with honey from their own hives. A fine experiment to show the tameness of these bees is to select a comb on which the queen is found in a stock in swarming condition, to leave in the hive, and lift out all the others and put them in a frame-box, fill up the hive with empty combs and cover it up; now get a vessel large enough to hold the bees, lift out the frames from the box one by one, giving each a shake into the vessel, when off will drop the bees. Now when you have done this (providing it is a smushy day of course), you can take off as many garments as you think proper, and just jar or knock them about as you like (they will stand any amount of jarring when not on combs), making them take wing, which they will quickly do, except the very youngest, and go back to their old hive, and if you get a single sting from them, just furnish an affidavit of the fact, attested by two credible witnesses and sworn before a commissioner duly appointed to administer oaths, or a justice of the peace, that it was a Syrian which did it, or I shall not believe it. I will stake my reputation that you will say the bee-master referred to does not understand Syrians; but we must not blame him for not doing so, if it is true he is a smoker and believes in the infallibility of smoke on bees, which quite accounts for his opinion.

I am very sorry that the character for fierceness was

given them by our leading bee-keepers, as it has deterred many from getting these bees, but, like many another truth, it comes out at last; and I venture to think many champions will be found for them, for undoubtedly they only require to be known to replace Italians, except with those who smoke; but then they might keep hybrids. Since I first gave instructions in managing these bees on pages 49, 50, Vol. XI., of the *Journal*, no one has had a word for them either bad or good. Surely those who have them can add their testimony either for or against. I hope to see the Rev. Geo. Raynor again giving his experience of them.

2nd, Are 'Syrian-blacks (*i.e.* the off-spring of a Syrian queen fertilised by a black drone) as amiable as pure black bees of average temper?' Answer, So far as I can judge they are; but their temper varies, one stock was quite as mild and tame as any pure Italians, and another was as cross as hybrids, that is, in the ordinary way; but the moment they had resolved to swarm, even before eggs were laid in the queen-cell cups, they were all of them 'cross' enough, flying at and stinging you when going near their hives, which they never do at other times. I consider this of great practical advantage, for with a stock of these bees with 75,000 brood from the egg up, and double that number of bees in the winged state working in the piles of supers and sections above, it is a great advantage to have a week's notice of their intention to quit, even if it is given with the point of a lance. I once had some pure blacks which I could not look at in the day time, even by peeping at them over a hedge twenty yards off. And which I utilised to prevent some fruit from being pilfered, and right well they did it too. For they would not be 'squared' anyhow, and no fear of being prosecuted for keeping savage animals; and perhaps the queen of the cross-stool of hybrids was mated with a drone of these.

3rd query I can't answer as I have not had or seen any.

4th, 'How far are the qualities of the first cross shared by a second cross, *i.e.* between hybrid queen and black drone, or black queen and hybrid drone?' Answer, between a hybrid queen and black drone the cross seems to be exactly like a first cross of Italians in markings, which are very mixed, and this is one point which seems to show that Italians are not a pure race. As regards other qualities, I cannot give an opinion, as I have reared but one specimen, the queen being only raised last July, and the bees did not get properly to work last year for me to judge. Between a black queen and a hybrid drone, I cannot say, not having had or even seen a specimen.—JOHN HEWITT, *Sheffield*.

#### TOMTITS AND BEES.

Some years ago, I was watching a tomtit tapping for bees and returning each time to a neighbouring post to eat it; on that post I counted seventeen bee-stings which he had pulled out. We are not troubled with them here; but a friend a few miles off catches numbers at his hive-doors in small gins; being a lover of birds he was both to believe what he had heard of these pretty little fellows, till careful observation convinced him that it was no libel.—W. E. BURKITT, *Buttermere Rectory, Hungerford*.

#### OBSERVATORY HIVES.

As 'Ebor's' letter asking instructions how to make a cheap efficient Observatory hive seems in a fair way of being relegated to the oblivion of unanswered communications, perhaps I may be allowed, if not taking up too much of your valuable space, to tell him how I made myself an observatory hive; and I may add it is very interesting to visitors to one's apiary to show them the bees in a normal state. I generally show visitors my

other hives, and then, as a climax, I open my observatory hive where the bees can be seen on all sides and the top at same time,—except, of course, when sections are on.

In the first place, my hive is made to hold ten frames Woodbury size. The woodwork of the hive cost perhaps 1s.; frames, 'Abbott's', 2s. 1d.; glass at 3d. per square foot, about 2s.; making a total of 5s. The outside cover is made of the pattern of Woodbury hives in general use, except that I have made mine with hinges fastened at front, so that the sides of cover and back can swing out of the way, and give a full view of three sides of the hive, viz., the two sides and the back without disturbing the bees. I made the bottom of the woodwork first, mortising the side pieces into front and back pieces, then the four upright corner pieces grooving each with two grooves to take the squares of glass, and mortising the bottom ends through the bottom frame; then the top frame I made to match the bottom frame mortised together, and with mortise holes at the corners to fit on tenons of upright corner pillars; and after placing the glass in the grooves, I put on the top frame, and there was the body of the hive with double glass sides with dead-air space of about an inch between the glass; and to crown all a glass crown board, or rather a glass cover to the hive; and I can assure you, Mr. Editor, that my stock of bees has wintered well in the said hive for two winters, but I have transferred the stock now into a Woodbury to make further improvements in the Observatory hive; and I may tell 'Ebor,' that I intend making a cover similar to the one of 'Gibbons,' advertised in *Journal*, so that I may be able to show visitors to my apiary the queen surrounded with her loyal subjects. Any further instructions 'Ebor' may want, if I have not made everything plain, I shall be only too pleased to give as far as I can.—WOODRIGH.

['Ebor's' inquiries were not altogether without results, having elicited two very simple and practical observatory hives, see Vol. XI.]

#### EDINBURGH INDUSTRIAL MUSEUM.

Allow me through your valuable *Bee Journal* to draw the attention of Scotch bee-keepers to the lack in the Edinburgh Industrial Museum of Scotch-made straw skeps, Stewartons, and modern bar-frame hives, honey, wax, &c. Also to suggest that they combine and furnish such a collection that would both be pleasing and instructive.—PANDY.

#### WILLESDEN WATERPROOF CARD.

In an article on 'Home-made Hives' in *B. B. J.* of January 1st, 'Subscriber' advises 'Crogon's Asphalt Felt' for covering hives. This is all well enough for a time (except that it is very hot in summer), but it must be occasionally tarred to keep it waterproof, and then one cannot touch it in warm weather without tarring one's hands.

The 'Willessden Waterproof Card' (I use 2 ply at 1s. per yard, 54 inches wide) has neither of these disadvantages, is cheaper and neater, and requires neither paint nor tar. I have used it largely for two seasons; some put on hives two years ago is still in perfect order, as good as ever.

QUERY.—Has any one tried the 'Willessden Card' for dividers in section racks? Ordinary card and paste board I know the bees will bite to pieces; but the 'Willessden' is so smooth and hard I doubt if they could. If it answers, it would be the cheapest and most handy article out. I am trying it for the sides of cork dummies. If the bees do not bite it, could it not be punched and used as excluders instead of zinc?—W. E. BURKITT, *Buttermere Rectory, Hungerford*.

## HOW TO PREVENT SWARMING.

Anything bearing on the above has always interested me very much, and at one time I believed it was a workable thing and pretty generally accepted by almost all advanced bee-keepers as a thing easily to be practised in an apiary wrought on modern principles. But as I never could bind my bees to any 'hard-and-fast' lines, I thought it was my inexperience, and as I grew older, and with more experience, I would find out all about it, and be able to do things like other folks. Since I imported into my apiary the Ligurians I have had less faith in preventing swarming than before. I think that blacks well managed could be kept almost on the non-swarming system; I say almost, for I never have been wholly able to prevent them issuing at least once, but after having been overhauled, some frames taken out, and more sections put on, they did not again come forth that season, but I find that no matter what room I provide for Ligurians they still go on to hive.

Mr. Simmins, of Rottingdean, in *Journal*, January 1st, 1884, like many others, only 'darkens counsel by a multitude of words;' for in his paper in the above number he does not teach how to prevent swarming at all, but how to make swarms, or rather by artificial swarming. I confess I like his plan, it is a good one where prevention is a failure, and one advocated long ago by a very thoughtful writer, Mr. Wm. Raitt. The plan adopted by Raitt was not on all points exactly the same as Mr. Simmins', but very much the same. Mr. Raitt at that time (in *Journal of Horticulture*) plainly stated that he had found that rigid non-swarming was a failure in practice, and he then suggested the plan similar to that practised by Mr. Simmins. There is a wide-spread idea abroad that the non-swarming system can be carried out successfully, and I for one do not believe it can with body boxes containing nine or ten standard-frames, and the sooner the bee world is told that the better, so that it may not be fighting against strong nature to a great loss of honey, and disappointment in every way. I would most respectfully say to men of great experience to tell us if bees can be kept from swarming. Then, how? Or, if it would be better to practise swarming, what kind? Or is Mr. Simmins' plan the *very best*? This is a grand time of the year for this discussion, so that we can be prepared for the coming season with our plans laid sure. I having a few hives all very strong in June, say six. They are all supered, and all ready to swarm at any moment. I don't want any more hives, I only want, perhaps, another one to make seven; but to act on Mr. Simmins' plan I could not have less than ten, to remove all brood-combs out of six, and put them into less than four; but he writes as if I would only have one very strong one, and all the rest ready to receive brood-combs from the one being manipulated. This I could not do in my apiary at swarming times, for if not just at the point of swarming the hives are all so full that there is little room for an addition of brood; in point of fact, I would rather take some frames of brood from them to keep them in peace. Long-hivists will smile at all these difficulties of mine, for with their twenty-frame hives they have no such trouble as I speak of, but then I tell them that I go in for sections alone, and these you cannot get off a twenty-frame hive. So that to obtain the two classes of honey it would require two distinct systems of management. To obtain sections under the non-swarming system is no easy matter, and to obtain them and allow the bees to swarm is also no easy matter in districts like this (Llister) where our glut does not exceed five weeks, and little or no heather in these parts. When bees swarm about the first or second week and returned again, they about half work, so that much most valuable time is wasted that might be economised on a better system being adopted. If I could 'master' my bees from June to 1st August I would consider I had gained my most

important point of management of the apiary. I fancy I can bring my army well up to fighting trim, but in action I am a poor general. I ask hints from other better generals through these pages. How would it do to remove the old queen at swarming point, and allow a virgin to take her place?—PADA.

## BLACK HONEY.

'Mr. H. Matthews' and W. Crisp' do not seem to think that this is blackberry honey; the latter seeming to think bees do not go any considerable distance in search of honey. Well, one spring I had a stock, the bees of which were coming in very heavily laden with honey; and no flowers being about I could not make it out where they got it; but as the bees left and returned in one straight direction, I resolved to follow the 'line,' when I came upon a cluster of stone-fruit trees—looked like plums—in a snug corner sheltered from north and east, in full bloom and covered with bees, and this was upwards of half-a-mile off. Again, last year, I had an apiary fully five and a half miles from, and in sight of, the moors in a 'line,' and my bees when they left the hive went and returned that way; the honey they brought in tasted and behaved in every way exactly like heather honey, and the bees dwindled down very much; while in another apiary a quarter of a mile farther off they had none of this honey. Now, no matter in which way I look at it, and bearing in mind many little items, almost too numerous to mention, to prove the contrary, I *cannot believe* they went that distance for honey; but still I believe they go much farther than some people imagine, as I have found my Syrian hybrids working *two miles away*; so very likely Mr. Crisp only failed to find them. Perhaps, it may help to solve the question if I give my way of finding out where any particular honey comes from; viz., I go to the suspected source, catch the heavily loaded bees, kill them and draw out their sacs of honey, which I mix into one, then I examine it for colour, and then taste it for flavour (of course it is thin, but the taste and colour are there); and I have no hesitation in saying the black, inky-looking honey I got, came from blackberries. I have seen bees collecting honey dew from a deceased-looking oak-tree two or three times, but never could catch them at it (owing to the difficulty of getting in the tree), to determine the colour and flavour; but I never saw them working on a vigorous-looking one. However, 'oak dew' may be black also, and there may be several kinds of 'black honey.' JOHN HEWITT, *Sheffield*.

## HOME-MADE HIVES.

'A Subscriber,' on page 45, says, 'The possibility of even a clever amateur making a *hive* has been stoutly denied by one of your correspondents.' Well, as all the correspondence published in the *Journal* is in existence, will he please give the exact particulars where a correspondent has made such an assertion?

I once made a remark to this effect regarding a certain kind of *frames*, to wit, Abbott's wide-ended one (which makes a hive of itself, and can be put into any box which may be large enough to contain it), but never hives, as ordinarily understood, as the context will show on reference to pages 207-1, vol. v. 'A Subscriber' does not appear able to make any kind of frames, but buys them ready made at 2s. 6d. per dozen—neither do I remember any one else saying so; therefore, I am anxious to know where it can be found?

When he has told us, I will tell him how he can make a seven bar-frame, half-inch, walled hive, complete with division board (minus the frames), planed, painted, and roofed all in twenty minutes for *ninepence*—no knock-in pieces, but a hive to be proud of.—JOHN HEWITT, *Sheffield*.

## THE HEATH APIARISTS.

In no other part of the German empire is bee-keeping in such a flourishing condition as in the Province of Hanover, the Dukedom of Brunswick, and some other provinces of Prussia, especially in that portion of the Province of Hanover called the Lüneburger Heide, where are extensive plains covered with the *Erica vulgaris* (*Heide*). Here live in scattered villages a great number of bee-keepers who get their livelihood by keeping bees. They are called the *Heidinker*, heath apiarists, and their bee the *Heidbiene*, or heath-bee. The bee is a species of the common German bee. These bee-keepers winter every year some 50 to 300 colonies, and increase them in the spring 200 per cent, from 50 to 150 stocks. In the fall they kill two-thirds by means of the sulphur pit to get their stores. If the year be a favourable one, the yield from seven or eight colonies will be a barrel of honey of 300 pounds. If you visit the heath apiarist you will see in his honey chamber (a room of his cottage) barrels full of honey from the harvest of the previous two, three, and more years. The greater portion of the honey in Germany is gathered by the heath apiarists. The majority of these men are cottagers and craftsmen. Their bees are their wealth. Their knowledge of bee-keeping has been handed down from generation to generation. In fact, the heath apiarists are so skillful in their management of bees, that the late Baron von Berlepch, one of the greatest bee-masters of Germany, after he had visited the Lüneburger Heide said, 'The most skillful bee-masters in all Europe are the heath apiarists.'

But you must not consider that the home of the heath apiarist is an Eldorado, a gold land for bees and bee-keepers. Nothing of the kind. From the beginning of the spring to the first of July the bees in the heath have not enough to live upon. You ask, perhaps, how is it possible to keep bees in such a country? Our bee-keeper of the heath knows how to shift for himself. Early in the month of March he packs his hives, 50 to 100, on a waggon, as seen in the accompanying illustration.

The *Biennen-tragen*\* (bee-waggon) is very simple, as you will see. The weather being at this time still cool, he conveys his bees during the day, and takes them some twenty to forty miles to the south, where he rents a corner of an orchard. Here he has built a beehouse. In this he places his hives in two or three rows on shelves, one above the other. Having secured his hives he goes home; but visits his colonies in the months of April and May three or four times to feed them if necessary till the beginning of swarming. Some years he feeds very little, when the bee gets plenty of honey from the willows, fruit trees, rape, and other honey plants. This last year he had no occasion to feed.

As soon as the swarming time has arrived, the bee-keeper will sit before his beehouse watching for the issuing of his bees. Every swarm is soon bived, though some days he may get ten to twenty, and even more swarms. At the end of the swarming time he has increased his colonies 200 per cent.

Now the time to go home with his bees draws near; buckwheat will soon begin to blossom, and swarming and the honey-flow in the south are over. Having prepared his bee-waggons, on the evening of a fine day he again packs his bees on them, and goes forth at night to his home in the heath. Should he be unable to reach his village before sunrise he is obliged to take his hives from the waggons, and set them a distance from the road-

side, open the entrances, and let them have a flight. After sunset he repacks the bees, and sets forward on his way. Some of the bee-keepers have their bees transported on the railroad.

Arrived at home, the bees will have a good pasturage from the buckwheat. On the 11th and 12th of August

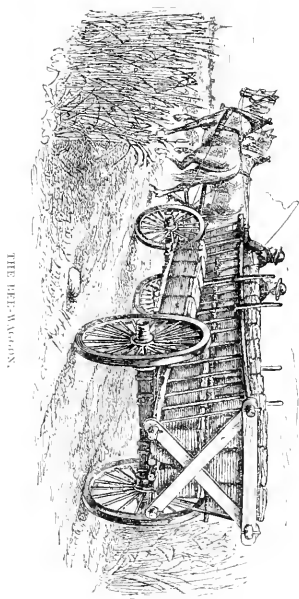

the heath, *Erica vulgaris*, comes into blossom, but this plant does not yield every year a good honey crop. By the end of September the honey harvest is over. As before said, two-thirds of the colonies are destroyed by the sulphur-pit, and one-third is kept for the winter. The way he is able to harvest pays the expenses of transport.

In my next I propose to give you some information respecting the hives in use in the heath. C. J. H. GRAVENHORST, Brunswick, Germany.

## Echoes from the Hives.

*Sheffield, January 10th.*—The weather here is just the wrong way about. Last night the mercury showed 52°, and to-day it is like May. I verily believe it was colder last July than any time yet this year; this month should be the coldest month of all. Crocuses nicely up, and from all appearances will be in full bloom in a fortnight; buttercups and daisies in profusion. — J. HEWITT.

*North Leicestershire.*—December proved on the whole a much quieter month for the bees, though they were on the wing several times, notably on Christmas Eve, when they were in flight from sunrise to sunset. They have been on the wing on the second and sixth of the present month. On examination to-day (9th) one stock was found dead, and several others at starvation point, though

\* The above engraving has appeared in *The Practical Apiarist* and in *Deutsche Illustrierte Bienen Zeitung*, edited by C. F. H. Gravenhorst, of Brunswick. Particulars respecting these will be found in our advertising columns. We are indebted to the kindness of the publishers for the use of the engraving.

they had been well supplied in October. All were remarkably strong in bees. E. B.

*Welling, Kent.*—I have had the whole of my fifteen stocks flying strong this last week; the weather is extremely mild for the time of the year. Of course they came back as they went, except being a little lighter. My bees have done well last season; my best stock, composed of three lots of comb-brood bees put into one hive, produced 76 1-B. sections, besides filling eleven frames. My system of wintering is in double-walled hives, with two dummies, so that I can pack with chaff all round, and five inches deep on top, with a small box four inches square over feed-hole, so that I can place a few pieces of candy on to make sure, or feed with syrup later on, by placing a piece of glass flat on top of the box I can see when they have eaten it, and I find it acts first-class in ventilating and purifying the hive. I put the chaff over the glass when not examining to keep heat in. I have studied and schemed a really fine observation-hive, for four combs, standard size, so that you can see both sides of four combs with bell glass, or super of any sort, in summer, and fine stock hive for winter combined, by changing the combs, double walls all round. I intend to exhibit it at the next show.

ALFRED CLAYTON.

## Queries and Replies.

*QUERY No. 733.*—(BEE-SWING.) *Brood in Supers.*—Will Mr. Samuel Simmins be good enough to state in the next *B. Bee Journal*, how he keeps his queens out of his supers without using perforated zinc? I lost a quantity of bees last summer by their getting through the zinc, and not being able to get back again. This happened in the top and side supers of one hive, in that hive about a pint of bees was thus killed in the middle of the honey season. In another hive with perforated zinc the loss was not so great, but I consider it an abomination in every way, the bees go much better into the supers without it, but how is the queen to be kept out? I lost two supers last summer by the queen filling them with drone-brood. I had 130 pounds of honey from five hives including the two spoil-supers, and three swarms and a cast. *A.* To answer this question fully, would require quite a lengthy paper, as nearly everything depends upon the manner in which the bees are fed and built up previous to the first flow of honey. I will, however, in as few words as possible, give the reasons why I can do without the queen-recluding zinc. The formation and arrangement of my crates and sections have some little to do with it; but whether such crates or the ordinary rack with American sections be used, the bee-keeper should always have his stock combs full of brood *before* they are put on. That is to say, with the exception of perhaps one or two pounds of syrup or honey, and some pollen. When supers are not put on until the hive is in this condition, which should be attained before honey comes in in any quantity, the whole of the surplus is carried above, and the queen is left in full possession of the hundreds of cells daily left vacant by young bees hatching out. Many do not build their stocks up in time, or do not put on sections until much honey has been stored in the stock combs; and when the surplus arrangements are at last in place, the queen will generally go up and spoil some of the new combs, as in both cases of neglect mentioned, the first stop of honey had to be placed in the body of the hive, and when the bees have once commenced to do that, they will do so all the season, because for the same reason they have been unable to breed extensively at the outset, and do not become strong colonies. One other thing I use no drone foundation in my sections. Where this is placed in supers, brood will nearly always

be found there, especially when all the stock combs have been built from worker foundation. I have found it useless to endeavour to exclude drone-comb entirely from the stock hive, as in swarming time the bees will raise drones somehow or other, and by giving foundation of that kind the bee-keeper is simply inviting the queen into the supers. The same management that keeps the queen busy below, also goes away with the necessity of continually extracting honey from the brood-combs, while working for comb honey.—SAMUEL SIMMINS.

*QUERY No. 734.* (BEE-SWING.) *Drilling holes in glass.*—Will you be good enough to tell me how to drill a pin-hole through the bottom of a glass bottle, as recommended by J. C. Douglas in his *Bee Culture in India*, in *B. B. J.* of December 1st, 1883. It is a first-rate idea for simple and cleanly feeding. *A.* Glass may be drilled by a well-tempered drill, such as would be used for drilling metal; apply it very steadily, and in dust, and with a drop of oil of thyme. This process requires great care, but is not otherwise difficult. Members of china and glass would do the work for a mere trifle.

*QUERY No. 735.* (E. T. C.) What capacity does one pound of honey take in cubic inches? *A.* The specific gravity of different samples of unclarified honey varies considerably, in accordance with the ripeness of the honey, or the evaporation of the watery particles; hence it is difficult to state the precise number of cubic inches contained in one pound of honey. As a general average, however, we shall not be far wrong in taking 28 cubic inches as the standard for one pound.

*QUERY No. 736.* (E. P. C.) *Post-war-few, Bivona.*—Bees being quiescent, can I now move hives eight or ten yards at once, and to the other side of a hedge? Would a disused croquet-ground in an orchard be a good place for hives? My gardener is not an enthusiast, and objects to bees stinging him as they did last year, often after they had been annoyed by interference with them, and I could move them out of the croquet-ground if objectionable. There is, of course, no shelter there. *A.* Yes; you may remove the bees, as proposed, with very little loss if the removal be made immediately. Let it be done in the evening, very quietly, with no jarring or shaking the hives. Be careful to place the hives, relatively to each other, in the same position as occupied formerly, and let them have the same external appearance. Remove all poles from the old place. The new position will be an improvement upon the old.

*QUERY No. 737.* (E. V. G.) *Sealed Honey.* Is it possible to leave sealed honey in comb too long to be extracted with Abbott's Little Wonder? *A.* If honey becomes granulated in the comb it cannot be extracted. All honey will granulate during the winter months, unless carefully preserved.

*2. Distance of Flight of Bees.*—What distance are bees supposed to go in search of honey? *A.* There are various opinions on this subject, some maintaining that bees will forage to the distance of six or seven miles; others that two or three is the extent to which they fly. We believe about three miles to be the greatest distance at which they can forage with advantage.

*3. Supercing.*—When is the best time for supercing? *A.* When honey begins to come in freely, and when the hives are full of bees. These conditions vary with the seasons and the locality, rarely occurring before the middle of May.

*4. Feeding.* Which is the best month to commence feeding?—*A.* This also depends on the weather and the state of the bees. As a rule, we never begin syrup-feeding before the end of February, and then only strong colonies.

*5. Card-board.* Will card-board do for separators?—*A.* No; the bees would destroy card-board. Tin, or wood, separators are the best.

## NOTICES TO CORRESPONDENTS &amp; INQUIRERS.

**JEDHART.**—The bees which you send are common black bees. The material is apparently felt, such as is used for covering boilers. It is a good non-conductor of heat and porous. It is an admirable winter covering or 'quilt.'

**INQUIRER.**—It is not advisable to lift out the frames for examination at this time of year. The bees which you found dead or crawling were those which dropped from the cluster and could not regain it and were consequently lost. You can ascertain pretty nearly the amount of stores left by lifting the quilt. At this period there should be three or four frames containing sealed food two or three inches down from the top and the outside combs nearly untouched. Next month breeding will commence and stores very rapidly decrease. Then will be the time to feed. We will refer more particularly to this point in our 'Useful Hints' for February 1st. If, however, you found the stores nearly exhausted, barley-sugar is the most suitable food for present use.

**T. H. VARLEY.**—1. *Pea-flour.*—Dredging pea-flour into empty combs and putting them into the hive is not likely to be of service. Some years ago Mr. Cheshire made pea-flour into a paste with honey and filled combs with it forcing it into the cells. The bees in some cases refused it, and in others accepted it. 2. *Warming Hives.*—If you artificially warm your hives in the house while the weather outside is too cold for flight, you will lose numbers of bees. They will leave the hive supposing warm weather prevails and be chilled and die. 3. *Starvation.*—The cause of some of your bees flying when others are quiet, is apparently starvation, which is also the cause of dead and dying bees on the floor-board. When did you last ascertain that they had 'plenty of store'?

**A. ROWELL.**—*Moving Bees.*—Your question has been several times answered in previous numbers. (See p. 19, and index to previous volume.) The chief concern is that each frame should be firmly fixed; that the hives be subject to as little shaking as possible, and that there should be free ventilation. Bees may be moved at the present time.

**J. P. DOUGLAS.**—For the last two years, examinations have been held at the Annual Show of the B. B. K. A. of those desiring to obtain certificates of their abilities as experts. As the time approaches, place yourself in communication with the Secretary, Mr. Huckle, who will advise you as to the nature of the examination, the books to be studied, and the degree of competency required.

**A. LOVER OF BEES.**—There is no doubt that many parts of Canada are very favourable for bee-farming. Mr. D. A. Jones of Boston, Ontario, who possesses perhaps the largest apiaries in America, is a notable example of a successful bee-farmer.

**N. PHILIPS.**—Is thanked for trouble taken.

**J. DAVIES.**—We are much obliged for extract from the *Illustrated London News* of 1851. We probably shall give it insertion in some future number.

**A. ROBINSON, Doncaster.**—*Bee-houses and Bee-hives.*—The house you describe will, no doubt, answer your purpose well. It should have an eaves-board in front and at back to carry off the wet; and if the entrances were separated by weather-boards, both vertically and horizontally, and painted different colours alternately, you would find it practically a great improvement. As regards the hive, the running floor-board we do not like, since it does not work in practice, becoming a fix-

ture by swelling of the wood, propolis by the bees, and the adhesion of wax-particles. A plain loose floor-board, projecting  $\frac{1}{2}$  inch beyond the hive on three sides, and flush in front, with an entrance cut in it, and one corresponding in the front of the house, is much better. The hive is then pushed close up to the front, and the bees are excluded from the interior of the house, the alighting-board being attached to the house itself. The floor-board should be clamped on the under side. The hive proposed will, doubtless, answer your purpose, but it is more substantive than necessary for use inside a house. The corner posts may very well be dispensed with, and inch-stuff—planed down to  $\frac{3}{4}$ —would be strong enough. If it were desired to place such a hive on a separate stand we should prefer a light outer case, with roof, as a receptacle, allowing three inches of space around the hive for winter packing, with chaff or other material—room being given above the hive for supering. On pages 136 and 137, vol. iv. of the *British Bee Journal*, engravings of these outer cases and floor-boards may be seen in the 'Raynor Hive' there portrayed. The fullest dimensions for hives are given in Langstroth's *Honey Bee*, and Root's *A B C of Apiculture*.

**THOMAS J. CRUSES, Ethard.**—1. *Treatment of Bees in Winter.*—There is little doubt that the Ligurian queen perished from the dampness and coldness of the hive in which you attempted to winter the bees. Glass is the very worst material for a winter hive. The breath of the bees condenses on the cold surface of the glass, and the moisture resulting therefrom causes dampness, dysentery, and mouldiness of the combs. After the catastrophe you did wrong in attempting to unite the bees to another colony. So small a number could have been of little advantage to another hive, and by attempting the union in *mid-winter* you ran the greatest possible risk of losing both colonies. If there is one thing of more importance than another in bee-culture it is this, that *bees should be never manipulated or disturbed during the winter months* in this climate. All unions, feeding, winter preparation, &c. should be completed by the middle or end of October, and from that time the bees should enjoy *perfect rest* until the middle or end of February. All excitement results in loss. To sprinkle your bees with syrup, and thoroughly to rouse them in the months of November and December, when they ought to have been at rest in a state of semi-hibernation, was most unwise, and it is probable that you will lose the other colony also. Your queen died in the hive, and was carried out dead by the bees. After introducing her no stimulation should have been used. A colony breeding through the winter is in an abnormal state, the young bees become dysenteric, the population dwindles, and death is generally the result. *Epericentia doct.*—2. *Bee-keepers' Associations in Ireland.*—There are two branches of the British Bee-keepers' Association in Ireland: (1) The Irish Bee-keepers' Association, Hon. Secretary, E. D'Olier, 9 Eustace Street, Dublin; (2) County Armagh Bee-keepers' Association; Hon. Secretary, Mr. G. Greer, Woodville, Lucan, Ireland.

**POOR BEE-MAN.**—Clarke's American is a cold blast smoker. It is much appreciated by those who use it. Having a large interior, it is chiefly used with pieces of decayed wood.

**E. LE P.**—Abbe Collin's *Natural History of Bees* (Paris: Levraut & Co.), and M. Layens' *Bee-Keeping*, are recommended. They may be procured through Messrs. Neighbour.

**CORRECTION.**—The Honey Fair at Grantham was established in 1877, not in 1867, as stated in our last.

200. 1. 1881

# THE BRITISH BEE JOURNAL

Communications to the Editor to be addressed to 'STRANDEWAYS' PRINTING OFFICE, Tower Street, St. Martin's Lane, W.C.'

[No. 139. Vol. XII.]

FEBRUARY 1, 1881.

[PUBLISHED FORTNIGHTLY.]

## Editorial, Notices, &c.

### PEEL CHALLENGE CUP.

In our last we mentioned that J. P. Jackson, Esq., of Liverpool, had conceived the idea of raising a Testimonial to the Rev. H. R. Peel on the occasion of his relinquishing the hon. secretaryship of the B. B. K. A., and, with the view of directing the attention of bee-keepers to it, had inserted in the *Beekeepers' Record* (the organ of the Lancashire and Cheshire B. B. K. A.) for Jan. 15 the following paragraph:

'Several of us who belong to the Lancashire and Cheshire Bee-keepers' Association have been associated with the "British" from its earliest days, and we look back upon the victories and exploits of its past with a peculiar satisfaction, arising from the fact that we ourselves have assisted in winning, or have been engaged in them. Since its birth, ten years ago, the British Bee-keepers' Association has led a most useful life. It has made considerable progress in the formation of a London Honey Market, it has got together a fine Library of bee-books, it has at its numerous conversations called forth many interesting, and some valuable contributions to our knowledge of bees, and it has bound together British bee-keepers in a common bond of unity and fellowship. What it has most cause to be proud of is, however, its unceasing work. By means of the many Exhibitions it has held, by the free lecturing tours throughout the country of its experts, and by the circulation of some 24,000 copies of its *Handbook for Cottagers*, it has educated the public mind and taste to such an extent, that the few bee-keepers that England possessed in 1871 number now many thousands, bee-keeping has been promoted to a national industry with us, and there are few English counties that have not now an affiliated Bee-keepers' Association of their own. These great efforts have taken place, and this wonderful success has been met with, since the Rev. H. R. Peel took the helm as Honorary Secretary of the Association. It is to his untiring labours, combined with an unlimited expenditure on his part of time and money, that the present position of British bee-keeping may be traced. It is therefore with the greatest regret that we learn that he is retiring from the office of Honorary Secretary, and we feel sure that all who know how he has laboured, and what difficulties he has overcome, will feel that a great blow has thereby fallen on the Association. We think that this occasion of showing in what esteem Mr. Peel is held by British bee-keepers should not be allowed to pass unnoticed, and

we solicit subscriptions towards the presentation to him of a Testimonial, which shall be worthy alike of the donor and the recipient.

This intention having been communicated to Mr. Peel, Mr. Jackson was informed that Mr. Peel declined to accept any personal Testimonial, Mr. Jackson then inserted the following in the *Record*:

'REV. H. R. PEEL, TESTIMONIAL FUND. It being understood that Mr. Peel is unwilling to personally accept anything in the nature of a Testimonial as usually understood, it will therefore rest with the subscribers to decide, as soon as the fund is closed, whether their memorial shall take the form of 1. H. R. Peel Bee Tent; 2. H. R. Peel Loan Collection of Bee Hives, &c.; 3. H. R. Peel Medal (Apary); or other suitable means of increasing the resources and usefulness of the British Beekeepers' Association.'

The proposed Testimonial having thus assumed another aspect, Mr. Peel has felt that he could not refuse to accept any expression of the good will of the bee-keeping world which would increase the resources and usefulness of the British Beekeepers' Association, and it appeared to him the most appropriate and useful mark of good-will would be a 'Peel Challenge Cup' to be competed annually for by County Associations affiliated with the British, the cup to be held annually by the County Association which shall exhibit the best display of sectional honey at a great metropolitan Honey Fair to be held about Christmas, or at the time of the Smithfield Show, or at the annual show of the British Beekeepers' Association.

Mr. Peel has suggested to Mr. Jackson the propriety of conveying a meeting of the county secretaries at the time of the B. B. K. A. General Meeting, Feb. 20th, and discussing the matter with them; forming a committee if the scheme recommend itself to them, and associating with them some members of the Central Committee.

The matter will in this way receive due consideration; and if the idea prove to be desirable, and tend to stimulate the County Associations, we feel assured that it will gladden the heart of Mr. Peel far more than any personal Testimonial possibly could.

## THE INTERNATIONAL HEALTH EXHIBITION.

We mentioned in our last issue that Messrs. Hooker and Stewart, two of the members forming the sub-committee to consider the necessary arrangements for the exhibition of honey, &c., at the International Exhibition, were about to have an interview with the executive department of the class in which Honey, &c., were to be represented. The interview with the Secretary was very encouraging. The space to be appropriated to Honey and Wax, and the various methods which lead to their production, has not yet been determined; though we fear that it will be much less than could be profitably employed by the Association. A guarantee fund has been commenced to guard against possible loss. It would be very desirable that the arrangement of the articles to be represented could be placed in the hands of the Association. If this could be carried out we might rest assured that this portion of the Exhibition would be a success, and that it would be creditable to the Association, interesting to the public, and give a fresh impulse to bee-keeping.

## BLIQH COMPETITION.

As, through the liberality of the bee-keepers throughout the kingdom, the B. B. K. A. has happily been relieved from the incumbrance of debt, it is desirable that the Committee should forthwith direct their attention to consider the best mode of repeating the Bligh Competition. A very general desire has been expressed that this experiment on a broader basis should be once more tried. The rules in the first instance were evidently not sufficiently elastic and explicit; but with the experience gained from the first, it will be the more easy to avoid the same difficulties in the second Economic Apiculture Competition. The committee, doubtless, would be pleased to have suggestions as to improvements in the rules, and the inducements that may be offered that other systems of bee-keeping besides the bar-frame, viz., the skep, the Stewarton, and so forth, might take part in the contest. We conceive that this is an experiment that the Secretaries of the various County Associations might take up with some degree of interest and energy, so that a proper spirit of emulation amongst the counties might be created. The Rev. G. Shipton, of Chesterfield, who has already offered a liberal donation towards the Prize Fund, has, in the present issue, suggested various alterations in the rules for the consideration of the Committee. We are also pleased to hear that several donations have been received towards the same fund. Sufficient progress has evidently been made to encourage the Committee in framing the new rules.

## ADDITIONS TO DEFICIENCY FUND.

W. Seabrook .. .. .	£0 5 0
Rev. W. V. Turner .. .. .	0 5 0
Beecon Association .. .. .	2 2 0
Rev. J. Lawson Sisson .. .. .	0 10 0
G. Hallam .. .. .	0 5 0
	£3 7 0

## COUNTY ASSOCIATIONS.

Reports of several County Associations for the past year are to hand. We purpose giving a statement of the number of Members of each Association. The following is the list already received:—

ASSOCIATION.	MEMBERS.
Buckinghamshire .. .. .	238
Dorsetshire .. .. .	177
East of Scotland .. .. .	144
Herefordshire .. .. .	112
Huntingdonshire .. .. .	69
Leicestershire .. .. .	127

## USEFUL HINTS.

The weather during January having been unusually mild has brought everything forward, and we hear from all parts of the country of birds building nests, spring flowers in blossom, and bees on the wing gathering pollen. But, within the last few days, snow has at last fallen in places, and, while writing, the house is being shaken by a furious gale with hail and rain.

Our first hint is one that may prove very useful, viz., *Do not be in too great a hurry to induce breeding.* We are not out of winter yet, and the advent of a severe frost, with biting easterly winds, would prove most disastrous to a stock with the brood-nest filled with brood, preventing that close clustering necessary in cold weather, and requiring food which the nurse-bees would have difficulty in supplying. The effect of the condensation of the bees to the centre of the hive would be to leave the outer seams of brood to be chilled and die, leading, according to some opinions, to foul brood. Although it is as well not to be too eager to commence, yet towards the end of this month the bee-keeper's season may be considered to begin.

**PREPARATION OF HIVES.**—On the approach of the breeding season a different arrangement of the hives is required. Whereas during the period of rest, our object was to give gentle ventilation, and so carry off the moisture arising from the breath of the bees, we now want all the moisture and heat we can get; a warm, moist atmosphere being essential to the welfare of the young brood. Therefore, always supposing the weather remain propitious, towards the latter part of February remove the porous quilts or trays of chaff, leaving one or two layers only, in which a hole must be cut for feeding, and on which place a board with hole corresponding. Screw the board down, if the construction of hive admit of it, or weight it with stones or bricks, so as to make the top of the hive as air-tight as possible. Remove all combs not covered by bees when at rest. If a hive is opened in the middle of a fine day, the bees will be found spread all over the combs. If the combs removed contain food unseal it, and place them behind the division boards, propping these up  $\frac{1}{2}$  inch, or making a small hole near the bottom to enable the bees to get at the combs. Stop all draughts, and reduce all entrances to allow only two bees to pass. Take every care to preserve the heat in the hive and to prevent robbing. Look to the stands, and if sunk at all, level the hives



before putting on the feelers. If they do not stand quite level bottle-feeders are apt to run.

**FEEDERS.**—Of these there is so large a choice in the market that every one has his favourite. A very good form is the divisional feeder as described in Cook's *Manual*. In this a flat-feeder is contained in the division-board, which is made hollow for the purpose. Abbott's divisional feeder has an inverted bottle instead of the flat. The great advantage of these is that no robbing can possibly take place, and also that no cutting of the quilt is required. Of those feeders to be used on the top the best are those consisting of a bottle having a tight-fitting cover with holes in it, which is inverted over a stage partly perforated, so that by turning it round one or more holes may be exposed. These may be had of most dealers. A simple bottle placed upon the lid of a tin box, with a single hole in it, and the whole quickly inverted, is the cheapest feeder, and with a little care is as good as any. It must be carefully covered so that bees cannot get at the food from the outside of the hive.

When the crocuses are in full bloom, or the latter end of February, may be taken as the time to commence stimulative feeding. It is not because a stock is well supplied with food that no feeding is necessary. It must not be forgotten that bees regulate their breeding, not so much by their possessions, as by their income. In a state of nature breeding would not naturally commence until there was an income of honey, but our bees are in an artificial state of existence, and we want them to be strong and ready to gather a surplus for us when the fruit-blossoms appear. Hence we must cheat the queen into supposing the honey season has arrived by giving food. The smallest quantity regularly given will be sufficient to stimulate her. But this must be steadily borne in mind, that when once feeding is commenced, it must be regularly continued, or more harm than good will be done. The syrup for spring feeding must be much thinner than for autumn. At that season we wished to save the bees as much labour in evaporating it to the proper consistence for sealing as we could. Now we must provide them not only food suitable for feeding their brood, but an excess of water with which to dilute the sealed food to the proper thinness. When breeding is going on a quantity of water is required, and many bees leave the hive in search of this necessary and are lost, or at any rate worn out by their labours, which might remain at home and help to maintain the heat, if they could find water in the form of thin syrup there. To commence, one hole of the feeder is sufficient; in the divisional feeders a gill, or less, given every night will be sufficient.

**ARTIFICIAL POLLEN.**—Although pollen may be had by the bees in almost any quantities for the labour of gathering, we want to save them that labour; and if they can find it in a sheltered spot within a few yards of the hive, many valuable lives will be saved. Almost any meal, if fine enough, will be taken, but pea-meal is the best. A little difficulty is sometimes experienced in getting bees

to accept artificial pollen, but by placing it in the cups of crocuses it will be quickly carried away, and once the taste is acquired the main supply will soon be found.

**APPLIANCES.**—Give your orders early. Manufacturers and dealers are every week becoming more busy.

**SKEPS.**—To prepare these for feeding cut a hole, if none already exist, in the centre of the top, about two inches in diameter, get ready a piece of wood with a corresponding hole in it, make a ring of clay or putty round the hole in the skep, and press the board firmly down, quite level. On this you can put a bottle feeder. If the board is about ten inches square it will serve to place sections upon when the hive cones. The cautions against robbing and draught apply equally to skeps as to frame-hives, as do also the general hints above.

**EXTRACTING HONEY.**—As the time is drawing near for making preparations for the coming season, it is desirable that bee-keepers should take into full consideration the relative advantages of extracted and section honey, and, therefore, we would desire to direct their attention to a well-considered article in another column on 'The Production of Extracted Honey,' by W. Dirty, jun.

#### REMARKS ON BEE FLOWERS.

My experience of bee-flowers, or those reputed to be so, has led me to discard many, and to retain and extend the culture of a comparatively limited number.

I have observed that bees, finding a good honey-yielding plant, in quantity and readily accessible, do not travel widely in pursuit of other flowers, nor do they make experimental essays of the numerous flowers between their hives and this main source of supply. The existence of that supply seems to be communicated to the occupants of the various colonies, for all unhesitatingly direct their flight to it. Masses of trumpet, or kale-bloom, and linnæums, claim, while they last, the almost undivided attention of the bees. It is another matter in early spring, when flowers are scarce and much distributed; then every opening flower is investigated, and the nectar and pollen distilled and exposed by the early Arabes, winter Aeonite, Crocus, and Wallflowers, are eagerly sought for. As the season of preparation is approaching, and it may be desirable to subsidise the natural pasturage with flowers of acknowledged utility, I will name those shrubs, hardy plants, annuals and biennials, which I have found acceptable to bees; and I will add a few remarks concerning those less generally known and cultivated. I will eschew all rare or expensive plants, or any that are not easily managed. Adaptability to various circumstances, a habit of free seeding, and facility of propagation, must be amongst the recommendations of a bee plant for general use.

*Hardy Herbaceous Plants.* Arabis, Aubrieta, Heliodorus niger, Epilobium angustifolium album, Veronica rupestris, Teucrium scrofolonia, Marjoram (knotted).

*Annals and Biennials*.—Clarkia, Borage, Linnaethus, Mignonette, Wallflower, Phacelia congesta, Trifolium (Persian), Buckwheat, Brassicas.

*Balls*.—Crocus, Winter Aconite.

*Shrubby Plants*.—Berberis, Erica carnea, Snowy mespilus.

There are three plants named under the hardy herbaceous heading which are sufficiently common, and are destined to be cultivated by bee-keepers. One has the merit of great beauty as well as utility. *Veronica rupestris*, or dwarf-growing free-blooming Veronica, is always sought for by bees. The next is a plant very common in the north, known as Wood sage, or Teucrium. I collected seed in Scotland, and grew a quantity; and, with the temptation of many brighter and sweeter flowers about, it nevertheless always attracted bees. Unluckily it was greatly in favour with humble-bees also. The third to which I wish to direct attention is the common knotted Marjoram of our herb-borders. No flower was so pertinaciously sought for as this while it lasted, and I have extended its culture. Amongst annuals, Clarkia alba may be mentioned, and my newly-introduced Persian clover, which has the scent of orange-blossom, and seems likely to become a good bee-flower.—W. INGRAM, *Bicester*.

MR. SIMMONS requests us to state that he wishes it to be distinctly understood that he does not deal in hives and appliances. He will, however, be happy to forward a 'pattern' of any article used by him at a nominal sum.

## AMONGST THE SWISS BEE-KEEPERS.

### No. VI.

We got up early the next morning and beheld the sun rise on the snowy head of Mont Blanc; and whilst contemplating the beautiful tints from the balcony, I heard the voice of M. Bertrand, who was ready for breakfast and then to visit his bees.

The apiary here at Nyon consists of Dadant hives, there being about thirty of these placed here and there in the kitchen-garden, including a row of about twenty, having a path behind them and protected from the north by a wall covered with fruit trees.

M. Bertrand has had considerable experience and success with the Dadant hive. This hive is similar to the Langstroth, but is a little larger, the frames being 18½ inches long by 10½ inches deep inside measure, and of which there are eleven. The hive is double-walled, and has a floor-board projecting in front for a distance of about 10 inches, and a porch like the Langstroth. There is a super which is provided with frames just half the depth of those in the body of the hive, and combs built in these are used for extracting. This hive being used principally for extracting, the appearance of the honey-comb is not of first importance, so one super is placed above another as long as the bees will occupy them and collect honey. At the end of the season the supers are removed, all the honey, which by this time is well ripened, extracted from the combs; and these are then fumigated with salicylic acid, as explained in my last article, in a cupboard arranged for the purpose, and are stored away to be used the next season.

If the supers are required to be used for sections, three 2-lb. sections just fill one of the frames, but M. Bertrand, like most of the Swiss bee-keepers, gives his

attention principally to the production of extracted honey. The hives are all raised a few inches from the ground, and the alighting-boards are made to touch the ground similar to the arrangement in my hives.

A building has been constructed and set apart for use as an extracting-house and store for frames, combs, honey, and all the small utensils necessary in the apiary. Here was a good substantial extractor of the 'Excelsior' pattern that had done good work, and a great variety of small apparatus.

M. Bertrand, at his own cost, introduces all the best bee-keeping appliances into the country, and places them at the disposal of the Swiss bee-keepers as patterns, and in this way does a great deal for the advancement of bee-keeping. There were also some very good honey barrels made on the same plan as those used for wine, also some large cans for holding 30 to 50 lbs. of honey.

Amongst various discarded apparatus was the Debeauxville hive, which is claimed by some French bee-keepers to be the first practical frame-hive; but it has nothing in common with our present hives, and is certainly very complicated, and I was not surprised to see it placed amongst the things of bygone days.

M. Bertrand does not consider Nyon a very good place for bees, as it is very exposed to cold winds, and, being close to the lake, they are able to collect honey from flowers on only half the area accessible to others situated further inland; but, notwithstanding this, the yield of honey is very good, averaging from 60 to 80 lbs., showing what can be done by a scientific bee-keeper even under unfavourable circumstances.

Some of the hives here had been transported to Allévays, and had returned bringing foul brood with them; but by taking proper steps the disease had been stamped out. We examined some of the hives and they were remarkably strong, and had no signs of foul brood.

As we were going to visit another apiary that day, we took the precaution to wash our hands in a solution of salicylic acid when we had done our inspection. I found that the same systematic order prevailed here as at Allévays, and came away fully convinced that M. Bertrand was a thorough bee-master, and not being in any way connected with the sale of appliances, his opinion of their merits is perfectly disinterested. May he live long to carry on the work he has so well begun, and by means of the Journal spread a knowledge of bee-keeping throughout the country!

I was very loth to leave, but the steamboat which was to take us to Geneva was approaching, and with a promise to return at some future time I left this hospitable family and hurried off to the pier.

M. Bertrand accompanied me, and our destination was Bessinges, near Geneva, to see the apiary of M. Fusay, who is Vice-president of the Société Romande d'Apiculture, and is an extensive farmer, cattle-breeder, vine-grower, and bee-keeper. The weather was charming, the lake calm, and the scenery sublime, and everything seemed to favour us in our expedition. The northern shore of the lake from Nyon to Geneva is a gentle slope, scattered over with villas and pleasure-grounds—very much like English country-houses, with here and there a large manse, the Jura mountains in the distance forming an agreeable and suitable background. On the southern shore the great charm of the prospect is the Mont Blanc and the range of the Savoy Alps, which, owing to the clearness of the atmosphere, was this day seen to perfection. Our journey to Geneva lasted an hour, but when we landed we felt it had been far too short, and we should have enjoyed staying on the lake the whole day, to gaze at the scenery and watch the picturesque boats with lattice sails, like those of the Mediterranean, moving along the surface of the water; the splashing of the oars and puffing of the steamer only breaking the stillness of the air. As we landed at Geneva, M. Fusay welcomed us, and we were

not long before we were *en route* for Bessinges, which is about three-quarters of an hour's drive from the steam-boat pier. On arriving there we were hospitably entertained at luncheon, and then went out to see the apiary. This is situated in a garden, and the hives, of which there are about fifty, were arranged concentrically, the entrances of the hives facing the centre, so that there were hives here facing every point of the compass being worked side by side. M. Fusay is one of those who has done the most in Switzerland to perfect bee-keeping appliances, and it was natural to expect to find a well-kept apiary. This we found, and we also found him ready to converse and impart his experience freely. I found the Layan-hive was the favourite, and this hive, which had been rejected by previous bee-keepers as being much too large, has, through M. Fusay's perseverance, become the leading hive in this part of Switzerland, yielding the best returns with the least amount of trouble. He has had something to do in improving its manufacture and applying methods which have also reduced the cost of manufacture. One of his improvements consists of an apparatus for fixing the wire gazes for keeping the frames the proper distance apart. Another is his feeder, by means of which any quantity of food can be given to bees very rapidly. This consists of a tin trough, which is let into the back of the hive about half way up, having a tube passing through the hive side, and connecting with it a small trough on the outside, which is fixed to the hive. Hinged to this is a flat bottle made of tin, and constructed in such a manner that when it is filled and turned up against the hive it closes the trough on the outside, the neck of the bottle reaching within about an eighth of an inch of the bottom; this being sufficient to keep the trough inside constantly supplied with syrup as fast as the bees consume it. The bottle can be filled every night, and just the proper quantity given without any danger of loss or robbing. For measuring the proper quantity of food M. Fusay has a graduated funnel with a valve, so that a large number of hives can be fed very rapidly.

When food is about to be administered, a button keeping the bottle upright is turned, the bottle then falls back on its hinge, the funnel is inserted in the neck, the proper quantity of syrup poured into this, the valve touched, which causes the syrup to flow into the bottle, and then by turning it up and fixing it with the button it can be left until more food is required. It takes much less time to administer the food with one of these feeders than it takes to describe the method; and although these simplifications may appear superfluous to those who have only a few hives to look after, the saving of time is of very great importance when it is a question of feeding a large number of colonies. M. Fusay goes in for queen-rearing, but uses small hives containing about twelve frames in each. He has a number of these small hives about, but the trouble is to stock a hive having a different-sized frame to that adapted for general use in the apiary. It is also a question if queen-raised in such hives are not very inferior to those raised in the parent hives. The bees kept here are all Italians, but M. Fusay has another apiary of black bees situated at some distance at Veiron. He makes bee-keeping a regular business, and supplies swarms, queens, hives, honey, and has lately commenced making comb foundation. This district is a good one for bees, living in the midst of well-cultivated farms and mountain pastures rich in honey-yielding flowers. Having a four hours' journey before me, and wishing to catch the last train to Montreux, I was not able to devote as much time here as I should have liked, and having spent a most enjoyable and profitable day, reluctantly took leave of our host, who drove us back to the railway station at Geneva.—THOS. WILKINSON.

## ASSOCIATIONS.

### BRITISH BEE-KEEPERS' ASSOCIATION.

#### ANNUAL GENERAL MEETING.

Members of the Association are requested to note that Monday, February 4th, is the last day for receiving notices of motions for the Annual General Meeting, to be held on Wednesday, February 20th.

Quarterly committee meeting held at 105 Jermyn Street on Wednesday, Jan. 16. Present: Rev. E. Bartrum (in the chair), Hon. and Rev. H. Bligh, D. Stewart, H. Jones, J. M. Hooker, Rev. H. R. Poel, W. O. G. Glennie (Treasurer), and the Rev. W. E. Barkitt (representative of the Wiltshire Association). The balance-sheet for the past year was submitted and read by the Assistant Secretary, and much satisfaction was expressed at the financial position of the Association.

It was resolved, That suggestions should be solicited in the *British Bee Journal* for the purpose of assisting the sub-committee in framing a revised set of rules and regulations for the management of a Second Economic Apiculture Competition. The sub-committee appointed to make inquiries respecting the exhibition of honey, &c., at the forthcoming International Health Exhibition, reported that the sub-committee had an interview with the secretary of the Food Section, and were informed that His Grace the Duke of Buckingham, Chairman of Executive Committee, and the Council, were anxious that an exhibition of honey and the several appliances used in its production, as thoroughly representative of the bee-keeping industry of the United Kingdom, should form part of the International Health Exhibition.

Resolved, That sufficient space be applied for as will enable the committee to arrange for an exhibition which should be thoroughly representative of the bee-keeping industry in all its branches. The following amounts were granted or towards any less that might accrue from this Exhibition, viz.: Hon. and Rev. H. Bligh, 5*l.* 5*s.*; Rev. H. R. Poel, 5*l.* 5*s.*; H. Jones, 5*l.* 5*s.*; D. Stewart, 5*l.* 5*s.*; J. M. Hooker, 5*l.* 5*s.*; Rev. E. Bartrum, 2*l.* 2*s.* The next committee meeting was fixed for Wednesday, February 13th.

At six o'clock the meeting resolved itself into a Conversation. Mr. Jesse Garratt (Secretary of the Kent B.K.A.) was voted to the chair.

The Chairman said that Mr. S. Simmins of Rottingdean, near Brighton, author of the paper to be read that evening, was unavoidably absent, but that Mr. Henderson had kindly consented to read it.

#### A PROVINCIAL EXPERIENCE WITH FOUL BROOD, AND HOW CURBED.

##### INTRODUCTION.

In presenting my experience to bee-keepers, through the medium of the British Bee-keepers' Association, I would draw attention to the infectious character of this disease, especially in the hands of the novice; and the worse than useless plan of endeavouring to cure it by anything less than the *total destruction* of the combs, and reducing the bees to a state of starvation before being placed in a clean hive on foundation.

I have purposely exposed my first blunders and ineffectual attempts to cure the disease, that the beginner may profit by the same, and not attempt to trifle with it.

I shall never forget my first experience with foul brood. It began the second year after I had commenced with the bar-frame hive. I had about a dozen stocks at the time, and its ravages were such that for many months I did nothing but buy new swarms; at first

open a few of the cells, when he will perceive the healthy larvæ within.

#### CHILLED BROOD.

Generally results from a cold snap after the weather has been mild enough to induce the bees to expand their cluster and brood-nest in spring. The sudden change to a lower temperature compels the bees to crowd together for their own protection, leaving the brood at the edges of the combs unprotected. All healthy and strong colonies will remove the chilled brood on the first warm day, and no harm results farther than the loss of that number of young bees. Should an accident occur by which the whole of the brood becomes chilled, as might happen by the hive being turned over, or the cover driven off during a gale, and the combs and bees be saturated with wet, something more serious than simple chilled brood might ensue, especially if the bees were unable to remove all the dead larvæ. Such cases should be watched, and if the brood is not thrown out within a reasonable time by the bees, it should be cut out and so prevent what might in time, if neglected, become foul brood. The beginner, with his first frame-hive, will often keep the combs of brood out from the cluster longer than is necessary, and this is a fruitful cause of chill, especially if his operations be conducted in cool weather. This practice cannot be too strongly condemned. No brood should be exposed to a low temperature, and even during summer all manipulations with brood combs should be carried out with care.

The liquid food surrounding chilled brood is licked up by the bees, and even when allowed to remain in the cells the older capped brood will generally dry up to a white cinder. The uncapped larvæ are removed first, but by keeping some away from the bees I found that it was many days before it would decompose, whereas that dying from foul brood would rapidly change colour and become rotten, adhering to the cell walls.

#### STARVED BROOD.

In spring, and sometimes in summer, it happens that a colony, which to all outside appearances is perfectly strong and healthy, and perhaps on the point of swarming, suddenly exhausts its stores, or the bees are unable through bad weather to gather sufficient for themselves and the daily increasing number of young bees in the larva state. At this critical stage their first impulse is to save themselves. They therefore commence to suck up the juices surrounding the brood, and those cells capped over are torn open, and the young of all stages of growth are then thrown out at the entrance; and if the first sign of the work of destruction is not noticed by the careless owner in two or three days more the whole colony will die.

#### CAUSES OF FOUL BROOD.

Notwithstanding other assertions to the contrary, I am positive that neglected chilled brood will in time create the disease, though perhaps it may be many weeks before it shows itself as such. I shall always consider this was what brought it on in my own apiary. As soon as I discovered my first case, I remembered that one morning of the previous June I had at five o'clock extracted the honey from every comb in the hive, and all contained brood in different stages of growth. Though not actually cold, it was chilly at the time, and the rapid circulation of cold air affecting it while in the extractor must have killed a large portion of the young brood. Probably the bees were not able to remove such a quantity, or perhaps neglected only a few cells, and the brood in time turned putrid, and thus started the fungoid growth of the disease, which spread farther and farther (though unnoticed by my then uninitiated eyes) until nearly the whole of the cells contained nothing but diseased larvæ. From what I afterwards knew of the malady, I was convinced that, considering the state in

which I found the combs, it must have originated some months previously, and, seemingly, at about the time I extracted the honey. There had been no fresh brood started since autumn, and what there was had sunk, and lying at the bottom of the cells so as to be hardly noticeable.

There were previously no other infected hives in the neighbourhood from which this stock could have robbed the honey, neither had the disease been communicated from imported bees, nor were they at any time subject to dysentery, which latter is sometimes considered to be the forerunner of foul brood; though for my part I believe dysentery is very seldom the cause, but more often it is to be traced to careless handling of combs containing brood, and of course in many instances to robbing. Large apiaries have been known to be frequently visited with and partially destroyed by dysentery, and yet foul brood is never seen among them; while in other localities, where the climate is such that bees can fly nearly all the year round, and dysentery is not known, foul brood is rampant, being brought on by the unwise manner of extracting honey from combs containing brood.

When once the disease has made its appearance, no colony in the neighbourhood is safe, as at any time stocks that have dwindled down from its effects are liable to be robbed, and all one can do is to endeavour to prevent its appearance in his own apiary by keeping his stocks supplied with disinfected syrup during spring and autumn, and doing all in his power to search out those of his neighbours that have any sign of the disease, and help them to cure it.

#### FOUL BROOD IN SKEPS.

Cottagers who are so unfortunate as to have the disease in their hives, are strongly recommended to burn every scrap of comb, as well as the skep, block, and huckle, even if they be otherwise in good repair. It will be mistaken economy to think of using such articles again, as the result will be only to perpetuate the disease, and dishearten the owner.

Should bees in these fixed-comb hives at any time become unprofitable, do not swarm, and show evident signs of dwindling, the bee-keeper should have his suspicions, and if, on turning up his hives, he finds few bees, and the combs containing brood, with the cappings black, pierced, and smoken, and giving forth a very bad odour, he can be assured he has the disease in its worst form, and unless he wishes it to spread to all the bees in the neighbourhood he must eradicate it at once. I have in this case supposed that the straw-hivist, having had no experience with it, will not find out the disease until it has reached an advanced state; and as by that time the few bees remaining will be old and worthless, they should be supplanted at night, and everything connected with the hive burnt there and then.

This is the only case in which I advise the destruction of the bees, as what few there are can never be utilised, and by endeavouring to save them the novice will probably cause the destruction of a thousand times their number in the future.

I would advise all who have had one experience to profit by it, and see that their neighbours' bees are healthy, and in cases where they appear not to be doing well, to obtain permission to examine such, and so put an end to the disease at once.

It is only by acting up to these directions that the malady can be stamped out; the greatest caution being absolutely necessary, or it will spread over whole districts, as is the case in some localities at the present time, where, instead of bee-keeping being one of the most profitable and pleasant of rural pursuits, it is rendered a source of constant anxiety and profitless labour.

In conclusion, I again repeat that neglected chilled-brood in the hands of the novice and careless bee-keepers

is the prime cause of foul brood; it is therefore very desirable that the beginner be impressed with the necessity of handling frames of brood with care, and not at all with a low temperature. Neither should he place combs containing brood in the extractor; if not actually chilled under the process, much of the brood is displaced and dies forthwith. In warm weather thin honey can be extracted from brood-frames by an expert without much danger, but a beginner should be imbued with a healthy dread of all such operations, and also be acquainted with the dire consequences of breaking these rules; when we may hope to hear of fewer outbreaks in the future.

[The discussion on preceding paper will be given in our next issue.]

#### WORCESTERSHIRE BEE-KEEPERS' ASSOCIATION.

The Annual Meeting of the Worcestershire Bee-keepers' Association was held on Monday the 20th of January at the Guildhall, Worcester, at 4 o'clock P.M. (Mr. W. B. Williams) was in the chair, and among those present were: Rev. C. W. N. Oulley, J. R. T. Suddon, Mrs. Dealing, Miss Wilson, Mrs. Kingsford, Mrs. Bidd, Col and H. W. P. Gully, Dr. Frank, Mr. C. H. Haynes, Mr. E. A. D'Amico, Mr. W. B. Handley, Mr. E. J. Moody, Mr. M. W. Edwards, Mr. S. T. Fildes, Mr. H. Baddock, Mr. R. C. Fildes, Mr. J. Partridge, Mr. T. Martin, Mr. A. W. R. Bliss, Mr. C. Brown, Mr. A. H. Martin (Hon. Secy.), and others. In all sixty people were present.

The financial statement showed receipts amounting to £132. 8s. 9d., including members' subscriptions, £53. 15s., bee-tent at Shows, £61. 15s. 9d., donations to bee-slavery and prize fund, £14. 9s. 6d., donation to Worcester Agricultural Society, £6., donations to fund the purchase of bee-tent, £13. 12s. 9d.. There was a balance in hand of £67. 11s. 10d.

Mr. A. H. Martin (Hon. Secy.) read the Report, which was most favourably received, and the Secretary was placed upon a firm basis, and assured well for the coming year. Last March the committee appointed Mr. C. Brown, of Dudley, to report to the Association. Mr. Brown has visited a great many of the members of the Association, he has a set of diagrams for besting, and the committee suggest that lectures be given by him in various parts of the county, as by this means great knowledge on the subject of bees and bee-keeping can be imparted. On June 18th, 20th, and 21st, an exhibition of bee-keeping, and apianian appliances, was held in Worcester, in connexion with the meeting of the Worcestershire Agricultural Society. In the month of June, the hon. secretary, after consulting with a few members of the Association, determined to order a bee-tent for its use, and this was obtained at a cost of 21s., and erected for the first time at Eye-horn, Rogatta and Horticultural Show, on July 27th. It visited Dudley and Welland in the same month, and was erected at Pershore, August 6th; Worcester, August 15th and 16th; Kidderminster, August 18th; Tenbury, August 23rd; Aston and Bank, August 25th; and Clipping Campden, September 13th. Mr. Brown conducted the manipulations in the tent on all these occasions, and also gave short lectures; and it was constantly crowded by a most attentive audience, and a great interest in bee-keeping was by this means created in the places visited, and many persons inclined to join the Association. The total receipts from the tent during the season have amounted to £207. 15s. 6d., and from this source and from donations amounting to £13. 12s. 9d., given by the members, the tent has been entirely paid for, and become the property of the Association, and after deducting the expenses at village and other shows, a balance of 157. 9s. 6d. has been added to the general funds of the Association.

Colonel Preedy moved the adoption of the report, which was seconded by the Mayor.

On the motion of Mr. Handley, Earl Beauchamp was re-elected President; Mr. Slatt, Hon. Treasurer; and Mr. Martin, Hon. Secretary.

The Rev. C. W. N. Oulley, in seconding the motion for the reelection of the Secretary, said that to Mr. Martin their thanks were specially due. The work had fallen heavily upon a busy man, and the Society would not have flourished as it had done but for Mr. Martin's assiduous work.

Mr. A. H. Martin said that he must thank them for having re-elected him as Hon. Secretary, and was especially obliged to Mr. Oulley for the kind manner in which he had spoken of the Association, and had referred to the Association. When he first took office he had no idea that it would prosper so well, as it has done, but he had the pleasure of having the objects of the Association had in view, and it had been so encouraged by the assistance he had received from friends, and the great interest and activity of the Association, and he looked forward to his next annual meeting with success in the coming year.

The hon. secretary was then elected.

A vote of thanks was then passed to the Rev. C. W. N. Oulley, and to Mr. W. A. G. Alderton, near Worcester, for their services.

Mr. A. H. Martin proposed a vote of thanks to the Mayor of Worcester for his kind greeting, and stated that his wishful hope was generally of the Association.

The Mayor subsequently thanked the hon. secretary, and the meeting adjourned to the next day, terminated.

#### DERBYSHIRE BEE-KEEPERS' ASSOCIATION.

The annual meeting of the Association was held in the Guild Hall, Derby, on Friday, January 18th, at 4 o'clock P.M. at the invitation of Mr. R. W. Chadwick, hon. Secretary.

The annual report of the Association was read, and received a favourable reception. It was reported that the Association, in Derbyshire, was very successful, and had become such a besting bee-keeping society as to have a membership of 146 members, and 129 colonies had been increased to 172. It was added that in the balance-sheet that the deficit balance was £27. 0s. 1d. In April the committee accepted the services of Mr. W. Handley, of Hereford, as expert of the Association. He had made 82 visits and examined 344 colonies. Birtsmorton, Trent, Leighton, Clay Cross, and Chestfield, were the principal places visited. The annual show was again held, by permission, on the ground of the Derbyshire Agricultural Society (to whom a vote of thanks was done), on September 6th and 7th. Mr. Edwards, who had held the post of hon. secretary for the past 7 years, had resigned, and Mr. Douglas Cooper, Sunny Hill, Nantmanton, had consented to take his place.

The Chairman, in moving the adoption of the report and balance-sheet, said the members of the Association might congratulate themselves upon the satisfactory increase of members, which was very much owing to the appointment and services of an expert. Mr. Handley had secured a good deal of support, and it was to be regretted that though want of funds he had not been able to pay a second visit to the whole of the members.

Mr. Holbrook seconded the adoption of the report.

The Chairman said the existence of the Association was entirely owing to the exertions of Mr. Edwards, to whom the members could not be too sufficiently grateful.

The president, vice-presidents, treasurer, and secretary, were re-appointed, and the committee were also re-appointed, with Mr. Edwards, Mr. Robert Clarke, and

Mr. Smith, of Uttoxeter Road, Derby, to fill the vacancies.

A drawing for two bar-frame hives took place (not reported); winners, Mr. R. W. Chandos-Pole and Mr. J. Cooper.

#### BRECKNOCKSHIRE BEE-KEEPERS' ASSOCIATION.

The Annual General Meeting of members was held at Becon on the 11th of January, 1884, when the Committee presented their second annual report. Two exhibitions of honey, &c., have been held during the past year. The season, on the whole, was a fairly good one, and the honey of superior quality. There is a steady increase in the number of subscribers, especially amongst cottagers, who are beginning to appreciate the profits of the humane system. A vote of thanks was passed to the Parent Association (B. B. K. A.) for their liberality in sending down a lecturer to the district. Mr. Blow delivered his addresses at Balith, Crickhowell, Glasbury, and Delynock. Although the lectures were not as well attended as they should have been, still they have been of great use in diffusing a knowledge of the objects of the Association. Lectures have also been delivered by members of the local Association, which have been well received. The meeting decided to make a donation of two guineas towards the special fund being raised to relieve the Parent Society from debt. A great want is felt in this neighbourhood for a resident expert to visit the apiaries of members at the critical periods of the year. At present there does not appear an likelihood of a competent person turning up in the neighbourhood. At the meeting it was thought that if some one could combine such work with the manufacture of hives and appliances there would be a fair opening for him. The accounts were presented by the Secretary, Miss Swinton. It appears that there is a balance in favour of the Society of about 17*l.* The Association enters on the third year of its existence with increasing hopes of progress.

#### HUNTINGDONSHIRE BEE-KEEPERS' ASSOCIATION.

The first annual meeting of this Association was held at the Fountain Hotel, Huntingdon, on Saturday, January 12th. A. W. Marshall, Esq., ex-Mayor of Huntingdon, presided, and there was between twenty and thirty members present. The annual report was read, and the balance-sheet presented, showing a balance in hand, after a very active year, of 1*l.* 3*s.* 10*d.* The report was adopted, and ordered to be printed and circulated. Mr. Marshall was then re-elected treasurer. The appointment of hon. sec. was next considered, and it was first agreed that district hon. secs. should be appointed, the selection to be left to the committee, and if possible the committee will also appoint an expert. Mr. White, in reply to the Rev. C. G. Hill, said that he felt able to carry on the work of the Association now that district hon. secs. and an expert, would be appointed; and as no one seemed willing to accept the office of hon. sec., he should have much pleasure in meeting the wish of the meeting by accepting the office. Mr. C. N. White was then unanimously re-elected sole hon. sec. The committee was re-elected with the addition of Mr. J. H. Howard, of Holme; Mr. R. Brown, of Earith; Rev. F. W. Crick, of Huntingdon; and Rev. J. W. B. Laurie, of Holme. A hive was then drawn for, the winning paper being drawn by Mr. Woodham.

#### CORNWALL BEE-KEEPERS' ASSOCIATION.

The annual meeting of the members of the Cornwall Bee-keepers' Association was held on Wednesday, January 23rd, at the Town-hall, Truro. The chair was

occupied by the Rev. A. H. Malan, and there were also present the Revs. W. Rogers, C. R. Sowell, and A. R. Tomlinson, Mrs. Polwhele, Mrs. Tom, Messrs. T. R. Polwhele, J. W. Wilkinson, G. H. Chilcott, G. Gradidge, C. Truscott, T. Peters, C. Sandoe, and C. Kent (Hon. Secretary).

The report stated that the committee had the pleasure of announcing a substantial increase in the number of members. There were now on the books of the Association 166 members, compared with 134 in January, 1883, an increase during the year of thirty-two. The total income for the year was 6*l.* 2*s.* 6*d.* Of this there had been expended 6*l.* 15*s.* 10*d.*, but there were still outstanding bills amounting to 1*l.* 7*s.* 10*d.* They commenced the year with a debt of 2*l.* 5*s.*, so that it will be seen they have succeeded in reducing by one-half the debt incurred in establishing the Association. The report having been adopted, the following officers were elected: President: The Right Hon. Earl Mount-Edgcumbe. Vice-President: The Hon. and Rev. J. Townshend Boscawen, Mrs. Collins (Truthan), Sir James McCard-Hogg, Bart., M.P., Rev. A. H. Malan, Mr. T. Martin (St. Austell), Lord Roberts, Sir John St. Aubyn, Bart., M.P., the Right Hon. Earl St. Germain, Mr. A. Pendarves Vivian, M.P., Treasurer: Mr. A. P. Nix, Hon. Secretary: Mr. C. Kent, Assistant Secretary: Mr. G. Gradidge. Committee: Mr. A. Bailey, Mr. W. K. Baker, Mr. J. Bonwell, jun., Mr. G. H. Chilcott, Mr. G. Dixon, Mr. G. H. Fox, Mr. H. B. Neame, Mr. W. N. Griffin, Mr. J. Bondy, Mrs. J. W. Hookin, Mr. J. Rows, Rev. J. A. Kempe, Mr. W. Procter, Mr. T. R. Polwhele, Mrs. Polwhele, Mr. J. Lander, Rev. W. Rogers, Rev. C. R. Sowell, Mr. G. Gradidge, Rev. J. Symonds, Mrs. Tom, Rev. A. R. Tomlinson, Mr. J. W. Willinson, Mr. J. Williams.

#### NORFOLK AND NORWICH BEE-KEEPERS' ASSOCIATION.

On the 23rd of January last the Annual General Meeting of this Association was held at Norwich, R. Harvey Mason, Esq., in the chair. In spite of the very stormy, wet weather, there was a good attendance, some members coming great distances, and from all parts of the county, showing the keen interest they took in the welfare of the Society. The Chairman read the Annual Report, and also the balance-sheet. The number of members appeared on the increase, and the funds proved most satisfactory. Expenditure during the year, 1877, 10*s.* 10*d.*, Receipts, 13*l.* 8*s.* 3*d.*, leaving a balance in the Treasurer's hands of 2*l.* 17*s.* 5*d.*, not including capital consisting of beehives, furniture, books, &c.

On this occasion the new committee were elected by voting-papers, each member present at the meeting taking a paper, and writing down and marking off those persons whom he thought desirable to serve on it. There were nineteen gentlemen nominated. Amongst them were the Rev. J. L. Sisson, Rev. A. E. Booker-Hill, Messrs. S. Barge and J. Rice. The following fifteen were, however, elected to serve on the committee for the ensuing year, viz., W. H. Beck, Rev. R. F. Belhuan, Rev. John Blake-Humfrey, J. O. Cattermole, Rev. H. Collison, Rev. W. H. Cooke, J. N. Eldridge, W. J. Gilbey, Rev. E. Harris, R. Harvey Mason, C. W. Middleton, Rev. J. H. Payne, A. W. Preston, Rev. H. Smith, Rev. W. J. Stracey.

Mr. H. R. Emms was unanimously elected Honorary Secretary in the place of the Rev. John Blake-Humfrey (resigned). Mr. G. H. Littleboy was re-elected Honorary Treasurer. These two gentlemen are, of course, *ex-officio* members of the Committee.

It is particularly requested that all communications should be addressed to the Hon. Sec., H. R. Emms, Esq., The Bank, Haymarket, Norwich.

ESSEX COUNTY BEE-KEEPERS' ASSOCIATION.

The annual meeting of this Association was held at the Corn Exchange, Chelmsford, on Friday, the 19th Jan. Mr. Edmund Durrant (Chelmsford) presided, and there were also present Mr. R. Christy (Boynton Hall, Roxwell), Mr. Robinson (Waltham), Mr. F. H. Mozey (Chelmsford), Mr. G. H. Aubrey (Springfield, Hon. Secretary), Mr. C. R. Finch (Great Baddow), Mr. W. Debanu (Chelmsford), and Mr. Robert (Sissex). The Hon. Secretary read the annual report, which stated—The increase in the number of members has been very satisfactory, fifty-six having been enrolled, while eight have been struck off, leaving a total of 186. In the matter of finances, the Committee have to report a balance in hand of *11, 6s. 2d.*, and, considering that there was a debit of *7, 1s. 5d.* at the commencement of the year, there was now a fair surplus, and, if we include unpaid subscriptions, the position of the Association may be said to be satisfactory. On the other hand, it must be remembered that an Exhibition was not held during the year, which would have considerably reduced the surplus. Lectures were delivered by Mr. E. Durrant at Brentwood, Coggeshall, Ingatestone, and Great Waltham. The expert (Mr. W. Debanu) paid visits to the apiaries of 121 members in the spring and to eleven in the autumn, who he examined 335 skeps, 264 bar-framed hives, and twenty-one box ditto in the spring, and twenty-four skeps and thirty bar-framed hives in the autumn.

The officers of the Association for the ensuing year were re-elected, with the following exceptions: The Right Rev. the Bishop of St. Albans was elected President in the place of the Earl of Rosslyn; Mr. P. Colley (Thoby Priory) and Mr. C. J. H. Tower (Wood Hall) were added to the list of Vice-Presidents; Mr. Edmund Durrant and Mr. G. H. Aubrey were appointed delegates to the British Bee Association, the latter taking the place of Mr. R. Christy; Mr. G. Trimmer and Mr. J. Self were elected up in the committee in the place of Mr. Corber and Mr. Chapman; and Mr. L. Durrant was appointed auditor.

BUCKINGHAMSHIRE BEE-KEEPERS' ASSOCIATION.

The annual general meeting of this Association was held on Thursday, January 17th, at the George Hotel, Aylesbury. In the absence of the president of the Association, His Grace the Duke of Buckingham and Chandos, the chair was taken by the Rev. Herbert R. Ford. The Hon. Secretary, the Rev. J. Selat, of Deponno Vicarage, Mids Hall, read the report for 1883. In it the members were congratulated on the remarkable success of the Association in its first year of existence. The members for 1883 exceed 200. The work of the Association for the past year was described at length. The balance-sheet shows a total income for 1883 of *104, 2s. 7d.*, whilst the expenditure amounted to *102, 10s.*, leaving a balance in hand of *11, 12s. 7d.* A list of names has been purchased at a cost of *28, 1s. 6d.*, without any special fund being raised for the purpose. Bearing this in mind, it will not be surprising to find that the liabilities at present existing exceed the assets by *14, 11s. 8d.* A second year of reduced expenditure will, it is confidently anticipated, remove this adverse balance.

The adoption of the report was moved by the Rev. T. J. Williams, seconded by the Rev. E. K. Clay, and carried unanimously.

Votes of thanks were unanimously passed to the President and Vice-Presidents, who were re-elected. The committee of 1883 were also re-elected, and a vote of thanks passed to them. The drawing for three hives then took place, the fortunate members being L. Harris, Bradenham, 1st prize; Rev. C. G. Hutchins, Dinton, 2nd; W. Oxlade, Cadmore End, 3rd.

GLoucestershire BEE-KEEPERS' ASSOCIATION.

You were kind enough some time ago to insert a notice in the *Journal* inviting any disposed to help in forming a Bee-keepers' Association for Gloucestershire to communicate with me, or with Mr. Slade, of Cheltenham. Only a few offers of co-operation were received by either of us, but I thought that some further effort should be made to ascertain if there was sufficient interest in bee-keeping to justify the starting of an Association in this county. I called, therefore, a meeting at Gloucester on Monday last, the 14th inst., to consider the question. Invitations were, of course, addressed to all who had communicated with Mr. Slade or myself, and to a number of others who we thought might be interested in the movement. Only three besides myself were present at the meeting, and, though we had letters from a few others expressing interest and promising support, we felt compelled to believe that there was not sufficient encouragement to justify us in going further. We should not like to abandon the idea of a County Association, but under present circumstances I fear it must be postponed.

If there are any apiarists in this county who think that there is more promise of success than our meeting of last Monday would seem to show, and who would like to make a further attempt, I shall be glad to co-operate with them, and to place in their hands the letters I have received offering support to an Association for Gloucestershire if it can be established. S. E. BARRITT, *Beckwith, Clebury, near Cheltenham, Jan. 19.*

Correspondence.

1884. Jan. 1. The Editor of the British Bee Journal, London. I have the pleasure to inform you that I have received your issue of the 14th inst. and am glad to hear of the success of your meeting. I have the pleasure to inform you that I have received your issue of the 14th inst. and am glad to hear of the success of your meeting.

IMPORTATION OF WAX.

The analysis of the statement on page 4 of value and quantities of wax imported from various countries does not show so large an amount spent in bees wax as might be supposed.

No less than 18,427 cwt., or nearly 52 per cent of the total, were reported from Germany and Japan. The 11,000 cwt. from the former country are of mineral wax, known as "candle wax," and the value is about 27, 14s. 3d. cwt., while the 7,337 cwt. from Japan consist of vegetable wax, of the value of about 27, 6s. per cwt.

The value of bees wax from the East and West Indies is about 6s. per cwt. That from the United States, which probably includes a proportion of mineral or vegetable wax, shows an average value of 3s. 18s.

Under the modern system of bee-keeping the consumption of wax for foundation-making is probably greater than the product from those combs made naturally by the bees, and thus bee-keepers themselves send money out of the country for wax.

The earth wax from Germany occurs in cakes about two inches thick, and about 18 inches long and 12 wide, of a bright colour, with no particular smell, but the fragrance is very different from that of bees wax. It enters largely into the composition of the so-called bees wax sold in shops. I replied to an advertisement of "Genuine Wax" in a publication devoted to the sale and exchange of articles by private people, and the sample sent me by the advertiser was this earth-wax pure and simple. E. L.





the arrangement which he points out. My improved moveable alighting-board meets the object in by covering the junction at front of hive, and in this way the hive is perfectly protected all round the bottom.—J. R. W. HOAR, *Tarrington, Ledbury.*

### BLIGH COMPETITION.

I regret that there has not been a more liberal response to your appeal for funds, with a view to organizing another Economic Apiaries Competition. But since there seems to be a general wish that the experiment should be repeated, I would respectfully suggest to the Committee that they should at once proceed to revise the rules, and make other necessary arrangements for the Competition, trusting that before the funds are actually required a sufficiency will be at the disposal.

The actual amount of prizes offered might be left uncertain; there ought not to be less than sixty, as before. And even though these prizes should be £5, £10, as could be desired, yet I think many of us would be glad to enter; and in this case the contingencies would amount to something considerable, and I might eventually be divided amongst the winners in due proportion, as in a sweepstakes.

I would suggest for consideration of the Committee the following rules:

Rule II. Each competitor shall be the proprietor of one colony, but in case of making more than one, shall pay entrance-fee for each; and every apiary diary and account shall be kept perfectly separate and distinct; no interchange of hives, bees, or colonies, or bees being permitted.

Rule VI. After 2½ months the prizes shall be finally realised and available.

Rule VIII. Although the sale of honey is not necessary to the rules, yet a preference will be given to those apiaries which show a profit derived either from the production and sale of honey, or from the sale of wax. GEO. SIMMONS, *Chesterfield.*

### 'HOME-MADE' HIVES.

I quite agree with your correspondent, 'A S. Bee-keeper,' that an amateur need not be 'clever' in order to make a really good hive. My experience in hive-making may be useful to some of your readers.

On reading Professor A. J. Cook's *Manual of the Apiary* in 1880 I became so interested in the subject of bee-keeping that I at once decided on making a Langstroth framed hive. Following Mr. Cook's instructions I soon completed my first hive. Having never seen one before I spent more time over it than was necessary; in May of the same year I drove a strong hive of bees and placed them in my new hive. Mr. Langstroth's book falling into my hands I decided on trying his hives, and made two. My 'Cook' hive gave me two swarms in June, which I placed in my Langstroth's.

My next venture was an observatory hive on the Langstroth principle, which I placed in my drawing-room window, and had the pleasure of seeing a queen-cell made, hear her call, and finally walk about on the comb among her subjects.

On the 15th September I took a super off my 'Cook' weighing sixty-five lbs. This ended my first year. Having to leave the north of Ireland, where I was residing at the time, I did not resume bee-keeping till 1882; since that time I have made thirteen hives, five of which are made out of co-operative packing-cases, in which my stores were sent, at a cost of nails, paint, and zinc under two shillings a hive. Cook's hives are 18 × 12 × 12, the wood in these and other cases was generally ½ inch thick, the ends one inch, the width from five to nine inches. It became necessary to build up my hives with many pieces. First I made my hive ½ inch

thick, then I covered it with another coating of ½ inch wood, being careful that the joints of the inner case were covered by the outer one. Very little planing was necessary; putty studded up all nail-holes, sandpaper made all smooth, and finally two coats of paint made it look quite equal to those made of solid inch wood. I have a colony of bees in one of these hives. They are in perfect health, and *quite dry*. The supers are of 1½ inch wood, the roofs of all shapes, being made to suit the width of the wood.—E. H. P., *Gloucester, 29th Jan.*

### SWARMING, &c.

I read with pleasure Mr. Simmons' article on swarming; he is evidently one of our most able and practical beekeepers, as his letters evince. I wish to ask him through the *Bee Journal* a question. I use a hive 25 inches in length, so ten frames or less as desired, and have sections in rear of brood-nest put up by exclusion-board, as well as in rear of frames. Now, I wish to know, if, instead of moving frames of brood to other hives, I could not, by placing the far end of their hive, behind the sections, and driving the front of their place as directed. As sections are of an inverted T, in these rear end ends, such as they had, I suppose could be extracted and placed in front of brood-nest.

As to the question of swarming, I have as desired a number of supers, and could add a number, though perhaps the present arrangement would have a better extra foundation for wax. I shall be very pleased if Mr. Simmons will give me a table on feeding and feeders.

I am, Sir, very truly yours, J. C. LAMBERT.

I point to your correspondent with the variable-sized sections, as a proposed plan. He will simply be enlarging the hive, and combing the wax in the sections placed above the brood-nest, and at once, while those sections in the wide frames shall be being drawn at the centre, with the edge of the sections behind and the frames of foundation in front, they probably be beyond of their contents for the purpose of being so fed and pollen. The returned swarms, if any, would not certainly occupy the brood-nest, as the bees prefer to the foundation, though some portion, and in time the whole, of the latter would be worked out, but all this would be done at the expense of the honey. I will shortly endeavour to show how my method of concentrating the whole working strength of a colony of the supers can be adapted to the requirements of those who can keep only a few hives. S. SIMMONS.

### HOW TO PREVENT SWARMING.

In answer to Paddy in your last issue I beg to give him my experience. In the first place, I don't use exclusion-zinc, neither do I remove or confine the queen at swarming-point. The kind of hive I use for obtaining supers is a common 10-frame, double-walled hive, with the roof in two parts. Towards the end of the month of October I remove two frames from each stock; again about the 1st of April I remove other two. I may also state that it is the outside frames which are taken, two on the right hand and two on the left. Very often we require to feed at this period, and by the 1st of June, if the weather is favourable, our six frames will be filled with brood. Our next work is enlargement; a frame with a sheet of foundation is inserted right in the middle of the brood-nest; in the course of three days another frame is given, and so on until the hive has reached its full size. We have now ten frames filled with brood. Our next work is a crate with fourteen sections (2 lbs. each); this we place on the hive, with what result? Every drop of honey except what is needed to feed the grubs is put right up into the sections. Where else could it be stored? In the course of a short time an-

other crate is required, all finished sections being removed. Very often I have three crates all at work on one hive. In a word, the whole secret is plenty of room, *but not more* than is required. When working sections I never use an extractor, and have no need for one; neither do I interfere with the brood-frames in any way—just let them alone. I might also state that honey is not abundant until about the 20th of June, and the first week of July is the ordinary swarming time. I often wish I lived in a district where swarming takes place in May.

One remark and I conclude, viz. keep super well protected; there should be an outer casing, and two inches of packing all round; this is of much more importance than bee-keepers are aware of.—A. COCKRUX, *Honey Grove, Cairnby Keith, N. B.*

#### PEEL TESTIMONIAL.

I am glad to see that Mr. Peel has 'put his foot down,' and has prohibited the testimonial. There could not be a better opportunity of stopping this nuisance, which has been the means of dis-integrating so many societies, for all would gladly honour our late Hon. Sec., and recognise the value of his incessant and self-sacrificing services, but a testimonial is not the way to show it. A testimonial is usually started by some one who wishes to bring himself into notice; and after a certain number of persons have been drawn into it, others do not see how to say 'No,' however they dislike the project, and when one is over another quickly follows, until the association is wrecked.—MEMBER B.B.K.A.

#### INTERNATIONAL HEALTH EXHIBITION.

I gather from the last copy of the *B. B. J.* that the B. B. K. A. have appointed a Committee to arrange for a display of honey, &c., at the forthcoming International Health Exhibition at South Kensington. Do you think it would be possible to get an exhibit of six 1-lb. sections and six 1-lb. bottles of run honey from every county in England and from various parts of Scotland and Ireland? I think it might be done through the secretaries of the County Associations, and the principal bee-keepers where no such body exists. It would be very interesting if it could be carried out, and I think the general public would take more interest in it than it would if the exhibits belonged to a few persons only, no matter how large they may be. There is one thing against it, viz., the Exhibition opens on the 1st of May, and there would be very little honey of either sort gathered by that time, and I am afraid that nearly all of last year's harvest would have been disposed of.—RICHARD W. LEAON, *Barbinton, Chipperton.*

We think the idea a good one if it could be carried out, but unless every county were represented it would hardly be satisfactory. Six sections and six jars from each would occupy a large space, and there could be no comparison of the respective products except in their appearance to the eye. We hope last season's honey will be admitted until the new can be shown; it will also perhaps be necessary to renew the exhibits from time to time, which might militate against the above suggestion.

#### THE PRODUCTION OF EXTRACTED HONEY.

Some time ago I promised to give the readers of the *Bee Journal*, the benefit of my experience in producing extracted honey, I therefore make the effort in the hope that beginners and amateurs like myself in the pursuit may profit thereby.

I do not intend this article for experienced bee-keepers, as I am quite sure they have other and more satisfactory ways of their own; but at the same time I hope they will compare it with their methods, and that

we may all have an honest, kind, and profitable criticism on the subject.

I am sure you are all agreed, that we can get nearly double as much honey by extracting as when we work for comb-honey, and we can also get extracted honey in some seasons when it would be impossible to secure any comb-honey. It is unfortunately the experience of us all that in some seasons a few days constitute the entire honey-gathering, and such was the case with me the past season. Now when we compare the price of each, 1s. per lb. for extracted, and 1s. 4s. for comb, and also the quantity to be obtained it will be evident that it pays much better for bee-keepers generally to work for extracted honey.

I do not wish to deter bee-keepers from producing those specimens of bee-handwork which we all admire, and which must ever remain a fancy article in our climate. I generally work one or two colonies myself every year for comb-honey, but I find it pays better to produce extracted honey. We then have not a lot of half-finished sections on our hands at the end of the season. How I work my bees then for extracted honey shall be the object of the following. I use a long hive containing twenty frames on the Combination or longitudinal principle, having double sides, and front with one-inch space between the sides packed with chaff and the back of the hive is single. Mr. Abbott who invented this style of hive has properly called it 'The best hive for the advancing bee-keeper.' Some may think a colony of bees would never increase to fill such a hive. My bees have filled twenty-frame hives every season, nay, more I have been obliged to put on a crate of supers to keep them from swarming. I have tried the doubling principle, and put this hive far before any double story hive for extracting honey. It is unnecessary here to state my objections to the double-story system. The great secret in successful honey-getting is to have strong hives ready to take advantage of a flow of honey when the weather answers.

In order to have our colonies strong at the right time each bee-keeper should study his locality and know when the bloom which constitutes his honey flow opens, and commence to stimulate his bees in spring, to have them ready to take every advantage when the elements are favourable. Here in my locality, I get nearly all my honey from white clover, which usually opens about the 1st of June, consequently I commence to stimulate and encourage my bees to rapid breeding between the middle of March and 1st of April. I do not attend to them by fits and starts, but keep up their breeding by feeding in greater or less degrees, according as the weather gives opportunity for gathering from natural supplies. By the 1st of June, I generally manage to have about twelve frames well filled with brood, and as soon as I see the clover out freely, I insert the excluder (described further on) enclosing nine frames as a brood-nest. Before I insert the excluder, I shake off all the drones (if any are present) from the frames I place behind the excluder, and I am careful to see that I have the queen in the front part of the hive. I also only put seven frames of brood in the front part, thus inserting two frames of foundation which gives the bees a little comb-building to do, and has the effect of preventing any inclination to swarm, and in fact in the after management, if I see the bees inclined to swarm, I repeat this operation of substituting a couple of frames of foundation for brood. We now have about five frames of brood behind the excluder, and in selecting these frames, I take those soonest to hatch which can be known by the capping to the cells.

If the weather is now favourable the bees will be storing in the evacuated brood-cells, and when the hive is at all crowded I insert frame after frame of empty comb or foundation until the hive is full of frames. In five or six days perhaps, all the brood will have hatched out behind the excluder, and about this time the honey

season will be at its height, and in the management of the frames in the honey-chamber will depend our success. The bees will generally accept the first empty comb after passing through the excluder to deposit their loads of honey.

As soon as the three frames nearest the excluder are about two-thirds full, I shift them to the back of the hive, and I repeat this until I have about nine frames out of the eleven in the honey-chamber from almost top to bottom—two-thirds full, with perhaps rather more than the half of each capped over. As soon as this is the case I go to the hive prepared with my smoker in full swing, a goose-wing or turkey quill, and we had better take a large table-knife with us. I throw both quilts back as far as the excluder; and here allow me to say, that our interference will be the more acceptable if we give the bees a complete smoking down before we make the first jar. I then take away eight of the fullest combs into our extracting house, thus leaving one comb pretty well filled which is placed again at the back of the hive. This comb together with what honey is in the other two will be a reserve to the bees in case the weather should break. It is not wise to take away all the honey, and if we have eight empty combs we can then trade combs with our colonies and thus be able to open and close the hives at one operation.

In the building into which we carried our combs, we should have a table, a large jug of boiling water, in which to immerse our uncapping knives, a plate or box to hold the cappings; and we might require some water in which to wash the hands from honey, and last, but not least, our extractor, which, if a cylinder machine, should stand on a level basis. Some of our juniors may ask what style of extractor is best to purchase. To those who have six or eight colonies, and who, in the near future, intend to keep more, I most decidedly say, purchase one of the Cowan machines. They are simply all that is required; and every time I extract with my machine I am the more pleased with it. However, there may be some to whom expense is everything, and who have few colonies and are not afraid of a little labour, and have good patience, such I would advise to get Abbott's Little Wonder. After uncapping our combs, we place them in our extractor, and turn just so hard that we can see the upper part of the cages perform a circle. A little practice will enable any one to get over a number of combs rapidly, and the extractor will hold about 10 lbs., the amount contained in our eight combs. When the extractor is filled to prevent working, raise it on a box about two feet from the ground, and tie a dammed strainer-bag on to the valve, and the honey will strain itself into a vessel below, and we can work away and let the honey strain all the time. This is a great saving of time when extracting from eight or ten colonies. I let my honey strain into 500 lb. casks, and when filled I tie the muslin cloth over each cask and store in some warm place. Honey thus treated will improve in condition, as evaporation and gravitation will ripen it considerably. We should skim all the thin stuff off each cask, and leave only a good and reliable article for sale or home consumption. The time required to produce the ripened condition of our honey will depend much on the state of the blossoms, on the atmosphere, and the length of time it has been in the hive. Flowers produce the thinnest honey at the first, and the thickest and best quality even to the stripplings. The experienced bee-keeper knows that when the morning indicates a day of electric conditions his bees will get most honey.

The foregoing management should be repeated just as often as the bees fill the combs; and if inclined to swarm, or place honey in the brood-nest, the bee-keeper must use common sense and take out brood-combs, and insert foundation and cut away queen-cells; in fact, the great aim should be to keep nothing but brood and pollen in the brood-nest, and honey alone in the honey-chamber.

A careful examination once a week of the brood-nest with applied wisdom will be the guide. During the honey-dut keep the entrance (which should be 10 or 12 inches wide open, and if the bees show themselves heated slide the cover of the hive towards the front, which will allow full ventilation, and at the same time the cover will act as a shade from the sun's rays.

All these and several other minor details will suggest themselves to the thoughtful and observant bee-keeper. Some may say that we would get more honey if we did not allow the bees to cap it over. Now in the end there is little difference, as we would then have to apply heat, or allow the ripened honey to settle to the bottom of some tall vessel and then skim off the watery stuff on the top. My plan gives us nearly all the honey in a ripe condition before it leaves the hive; and at the same time as fast as the bees fill each comb they are placed back to allow the heat of the hive to ripen it, and an empty comb is placed up against the excluder to encourage the bees to increased exertion. There is no artificial means yet discovered that will ripen honey as well as it can be done in the hive. It is therefore taken out rich, oily, and agreeable flavour depending to the palate of the British public.

When I am exhibiting honey I always take care that it has been all sealed over, and exposed and messed about in the open air as little as possible.

The excluder is made out of an ordinary dummy, with cross-spaces at the ends to prevent warping. I cut a rectangular piece about ten inches long out of both top and bottom and leave about two inches of wood between the two. I nail on the zinc so that it comes down to touch the bottom board, and the top piece reaches and is nailed on to the top board of the dummy so that the bees have every opportunity of going to and fro.

My favourite time for extracting is about an hour before the sun is on, as the bees are nearly all returned to their hives and are not so troubled with the flying bees from other colonies, and can do our work quicker. Besides, in the evening the bees have ceased to gather for the day, and we thus do not lose a day's work, or they are all settled down before morning; and another reason is the shades of evening prevent any inclination to rob, and we can work quicker, not being exposed to the heat of the sun.

In conclusion, I may say I have obtained in one harvest more than have some of our able-bodied beekeepers who work on another plan, and who have equally as good a locality. I adopted this management three seasons ago and have had success every season, comparing and talking into one out the weather. There is no subject of greater interest to the beekeepers than securing the greatest amount of honey from his bees; and I hope this subject will receive full ventilation in the *Journal* this coming spring, and that we may have a general commingling of the best ideas and modes of procedure to the advantage of us all.

I often think our old and experienced beekeepers are too reticent in communicating their ideas, and that they forget that our ranks are being continually swollen in numbers by beginners. Again hoping that this article will encourage and assist the readers of the *Journal*, and if so, the writer shall feel amply repaid for any little efforts made on his behalf. If there is anything that I have omitted, or that any one does not understand, say so through the *Journal*, and I will try and explain again.—W. DUFFY, JUN., *The Apiary, Mordun, New-towards, Co. Down, Ireland.*

—FRENCH ACTION. Between the 19th and 23rd of January, some evil-minded person or persons destroyed with burning brimstone eleven stocks of bees, cut out the honey-combs which they carried off, and smashed up the other combs and frames belonging to Mr. W. F. Garnett, of 12 Sharrow Street, Sheffield; the motive being, it is supposed, to get the little honey the bees had left.

## Echoes from the Hives.

*Herts, Somersham, Jan. 23rd.*—The weather during the past month has been very fine and mild. Rain has not fallen till to-day, and now it is accompanied by a very high wind. The average mid-day temperature for the month has been 48 degrees, the lowest mid-day temperature was 43 degrees on 18th and 19th. The thermometer was lowest on the mornings of 14th (32 degrees), 16th and 19th (31 degrees). Bees have been out a great deal. Many stocks are at starvation point in consequence of the owners neglecting to feed after such a bad season as we had here last year. I found two crocuses in flower on Monday, and to-day, temperature 52 degrees, I saw about two dozen more. Primroses have already been gathered here. I have quantities of snowdrops in bloom.—C. N. WHITE.

*Devonshire.*—During December the weather was variable, for the most part mild, although we had a few days of frost, there were twelve wet days with a total rain-fall of 2.42 inches; the most in twenty-four hours was on the 10th when .59 inches fell. The corresponding month in 1882, there were twenty-six wet days with a total rainfall of 6.33 inches. The total fall for 1883 was 42.83 inches, which compared very favourably with the previous year; in 1882 we had a total rain-fall of 52.54 inches. Bees have generally been quiet. As I have often remarked there is still a very great deal of ignorance prevailing with the public with reference to apiculture; the other day a lady, whilst buying some comb honey in a fashionable shop in Dublin, remarked that the comb was dark. 'Oh, madam, that is accounted for by the young bees having made it, as it is some time before they are able to make it of a lighter colour.'—W. N. G., *Hon. Sec. D. & E. B. K. J.*

*Leighton Wells, Kent, Jan. 21, 1884.*—No better proof of the abnormal mildness of the season can be given than the fact that the bees in this neighbourhood have commenced breeding. I noticed them to-day at work on the furze-blossom, and found they were bringing home pollen in considerable quantity. Most of my hives are very light. I am feeding with barley-sugar, but entertain a good deal of apprehension as to the state of the strength of the bees by the end of March.—F. STIMMONS.

*Warwickshire, Honey Cott, Weston, Leamington, Jan. 23rd.*—Nearly the whole of the month has been very mild, with two or three foggy and many dark dull days, but fine, so that bees have been very much on the wing, and on the look-out for flowers. I saw a few on some *Arabis alpina*, commonly called here *February-May*. I saw a bee come in loaded with yellow pollen on Sunday, the 13th, which, I expect, was collected from gorse or furze, of which there is a nice lot in bloom round about in waste places. Monday, the 21st, the bees were on the wing very much, nearly all day; they were out so much as to look like swarming—a pretty sure indication of change to bad weather, which began next day with very windy, and to-day very wet and stormy weather. I have not been troubled much with tomits since I shot half-a-dozen of them.—JOHN WALTON.

*West Gloucestershire, Jan. 23, 1884.*—The month of January has been hitherto one of the mildest on record. The first week was very foggy and damp, rounding one very much of November. Since then it has been dull and very mild, with occasional gleams of sunshine. Consequently, bees have been on the wing, more or less, every day. Yesterday, the 22nd, the weather changed, and it rained a regular down-pour for eighteen hours, blowing a gale all the time, which still continues with every appearance of more rain. I examined my fourteen hives on the 3rd, and found all well and healthy, plenty of bees, and a good supply of stores; and although the season has been so mild, I find the bees have not con-

sumed more food than they do in an ordinary season. Shall we suffer for this mild weather as the spring advances? I trust not.—J. B.

*Sheffield, Jan. 28th.*—Since the 10th the weather has been somewhat colder on the whole, though still too warm. Snow has fallen several times the past three days, but quickly disappears; the rule now seems to be strong gales, rain and snow, but the wind is nothing in comparison to the 'blow' which visited us on the 12th ult., and overhauled trees, roofs, stacks, buildings, and all but one stock of bees in one of my apiaries, though I considered they were safe against any wind I ever knew to blow in this country. At first sight I thought they were done for, but those with fast floor-boards were no worse (quilts all in place), while two with loose ones suffered very much—the wind getting between the combs, chilling the bees, and blowing them away, however by warming and uniting I only count one less. A week ago *Arabis alba* was coming in bloom freely, but if we get a little frost it will keep it back until a more seasonable time of the year.—JOHN HEWITT.

*Weyford, Egham, Jan. 30th.*—Weather mild, thermometer at 48. A great number of bees flying about in front of apiary, apparently as busily working as if in mid-summer. *12th inst.*—Thermometer at 50. Not so many bees out as on the 30th, but those which were seen going to, and coming from, a plantation near at hand. Subsequently saw four bees take the pollen. What is the earliest date I could purchase an Italian queen, and from whom? Would she come safely by parcel post?—J. J. CRUICK. If properly packed, the queen could be sent safely by parcels post. Our advertisements will give you the information as to the time and from whom queens can be purchased. It would be invidious on our part to indicate our preferences.

*Newtownards, Co. Down.*—The winter here has been very mild, and in consequence bees have been flying very often, and have consumed a great quantity of stores. I examined one colony early in January, and I found they had used a great deal of food. I would advise bee-keepers to keep a sharp look-out for starved colonies as the season is deceiving from that of previous years. The blacks are wintering best.—Wm. DUFFY, JUN.

*Cork, Jan. 19th.*—The weather here has been extremely mild. To-day and on fine days bees are bringing in pollen, and flying in and out of the hive as if it were summer. On the alighting-board of one hive a number of the bees killed another, one of them flew away with her about ten yards, let her drop and returned to the hive. Could this have been a robber bee? All my hives have honey in the combs and candy on top of frames. I think it is strange that the only hive in which I have noticed any killing of bees, in autumn and now, is my strongest stock and the only one with a zigzag entrance as recommended to prevent robbing. They are, however, a very cross stock, and perhaps fight between themselves.—BOZ.

*Ballaunacra, Co. Cork.*—No echoes from many, as starvation has told its tale on the already diminished number of straw skeps in this country, which have been getting fewer every year. Many of those I transferred to bar-frame hives had not an atom of honey in them. Old-times bee-keepers cannot understand why all their bees have died, so many and so great losses are a strong argument in favour of bar-frame hives, so easily can bees be fed and managed in them. Not having fed up sufficiently early, and from the length of time the rearing of brood was continued, I was obliged to give a cake of sugar over the frames of each hive, that kept them in movement all this fine winter, so that hardly a day passed but some were on the wing. Extraordinary as it may appear, I saw pollen being taken into a hive on Christmas day. On Sunday, 6th January, I saw it being taken into several hives; and on Sunday, 20th, bees were

very busy. I timed nine bees going into one hive with pollen in one minute, while steady work was going on the same day for a considerable time through my apiary; but I fear that should cold, hard weather come it will be injurious to brood that I expect may be in each hive. I did not wish to disturb the bees by looking to see if it was there. Unpropitious as the honey seasons have been of late years we must only hope for better.—J. J. SMYTH.

## Queries and Replies.

QUERY No. 728.—(GEMAN, *Isle of Man*).—1. What are the bees' hours of business?—A. From sunrise to sunset when the weather is warm enough.

2. (a) Does a southerly aspect really get more work out of bees? (b) Is not abundance of light and elbow-room all that is required?—A. (a) No. (b) Yes.

3. When does the second or heather campaign end finally?—A. It depends upon locality and weather; but, generally speaking, from first week in August to second week in September.

4. Would you approve of a triple hive, 6 feet long, entrance to two at the sides and to one in the front?—A. We greatly prefer each stock of bees to be in a separate hive and on a separate stand. For the reason, among others which would take too much space to enumerate, that the manipulation of one lot in a single occupation hive disturbs the others, and if you do not smoke all, you are attacked.

5. Do you think the situation suitable for an apiary, (as sketched); is it the best I can find. A. We would not advise any of the entrances facing due north and due east, as shown in sketch; but should turn them to the south or west giving them as far from the wall as possible.

QUERY No. 729.—(C. W. F.).—1. *C. clypeator*.—Can comb-foundation, obtained first summer, be used this year?—A. Last year's foundation may be used this year. It becomes brittle if in a warm place for a few hours.

2. If so, is it of any use if it has become mouldy? Is there any means of cleaning the mould off?—A. Brush off the mouldiness, and sponge or brush over with weak salicylic solution, which will prevent its forming again.

3. What is the best way of feeding in spring or a round-topped skep?—A. You will find it convenient to fit a square board to the top of each round-topped skep. Put a ring of clay or putty round the top, and pass the board, which must have a hole in the centre, down it. On this you can place your supers or feeders, which may be of similar kinds to those used for bar-frame hives. Take every care to prevent robbing.

4. Is it possible to feed in summer upon the top of a super in bad weather? If so, how?—A. In the event of the weather becoming so bad as to necessitate feeding, remove the super and feed, replacing it on the arrival of better times.

5. What should be the size of the hole in what is considered to be "finely perforated" zinc?—A. Perforated zinc for feeding purposes (on which to stand a bottle) may have holes of any size, small enough to prevent the bees getting out when refilling the bottle.

6. *Sleps*.—Where can instruction be found on the art of skep-making? Would not a paper or so on the subject be a good thing? It is difficult in the country to get skeps made to order.—A. First, get some long trailing hairs. Cut off all thorns—those without side-shoots are preferable—split into three, scrape out the pith, and point one end. But by far the easier plan is to buy some split cane, which cost from 2s. 6d. to 3s. per lb. Next, take some nice, clean, straight wheat straw, cut off all the ears and strip off all the flags or loose hanging pieces; *strip, and wet*, the straw. Next, take a ring of about 1½ inches in diameter (a common curtain ring will answer the

purpose well.) Now take a roll of damp straw, about as thick as your little finger at the thinnest end. Tie a piece of string tight round the level thin ends, slip on the ring; take the roll in the left hand, then



bend the straw round to form a circle thus:—Tie at the junction. This forms the hole in the centre of top. Proceed to sew round with the cane, increasing the stitches each round; after the first increase the straw until the thing is full; gradually twist it away from you. The ring must be kept full, and gradually pushed back as required; when round enough are done to make the top the size you require, thus:—Bend the straw so as to form the first round of side. Continue until the hive is as large as you require it, when the last round must be gradually tapered to make a new level finish, N.B. Each stitch of the cane must be passed through the stitch before it, also a portion of the straw to fill up the crevices, thus:

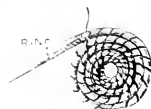

The dots show the underside of cane.

7. *Useful Hints*.—Are the 'Useful Hives' given monthly last year published separately? They would be exceedingly useful to distribute among cottagers, and for insertion in Parish Magazines. A. The 'Useful Hives' are not published separately. We would, however, be very pleased to see them reproduced in the various Parish Magazines. It is our general practice to issue them on the 1st of each month.

8. *Beehive*.—Is there any list in back Numbers of the *British Bee Journal* of bee-keepers with their *comarca* attached? If not, may we have one?—A. Detailed names are useless to those unacquainted with botany. A. In No. 116, Vol. X, p. 176, you will find a complete list of beehives under their common names, with their relative value for beekeeping purposes. Consult also the indices, Vols. X, and XI.

## NOTICES TO CORRESPONDENTS & INQUIRERS.

J. B. *Doobling*.—The doubling system would not answer the way you suggest. You had better make a box to contain the number of frames you propose to use, an extracting and place it and the frames on top of your Combination hive, making a lift to the roof, and deep enough.

D. *Doobling Location of Bees*.—You are likely to do fairly well where you are situated, unless the ground is wholly occupied by market-gardens, which are devoted to vegetables for table. These are the worst crops for bees, not only are they not allowed to blossom, but all weeds are kept down. In suburban London the gardens are so filled with flowers that bees can get a living in summer; but do not store a surplus, and must be fed for winter.

C. W. Do not attempt to give your bees a flight in a greenhouse, very few will find their way back to their hive. You may, with a little trouble, make a flight apparatus, with muslin stretched on hoops, made bee-tight, and fastened over the front of the hive.

J. E. ROSEMAN, *Leatherhead*.—*Skep-Doubling*. We have no experience in the 'doubling' of skeps. In the case of skeps 'doubling' would be merely another name for 'storifying.' The term 'doubling' is applied to movable-comb hives only.

C. POLYAKO, *1. Diminution of Bees*.—Your handful of bees, if they have a vigorous queen, will probably build themselves up into a strong lot, but the cause of their small number may be queenlessness. Leave them alone for the present; reduce the size of the hive by removing side frames, and close up the division-board, and do all you can to prevent loss of heat. 2. *Carrying*

*through Winter.*—Yes, by the addition of a frame of sealed brood when the weak lot have (if they do so at all) increased sufficiently to cover it until hatched. 3. *Old and Young Bees.*—The old bees adhering to the comb will fly home; the young ones will remain.

JOHN J. SMYTH.—Consult Roy. G. Raynor's paper on *Bee-houses*; price, 3d., to be had of Mr. Huckle, King's Langley, Herts.

H. *Bideford.*—Your suggestion will receive due attention. FRANK BENTON, *Manch.*—There was nothing absolute in our statement. Perhaps it would have been more precise to have substituted 'Canada' for 'America.' We can assure our correspondent that the respect in which the hono'ed names mentioned are held by all British bee-keepers is only second to his own.

A SUBSCRIBER, *Quandle.*—1. *Spreading Brood.*—When the bees cover the seven combs you may introduce a comb into the centre of the brood-nest. This will, probably, not be required before the end of March. See Mr. Cowan's book under 'Spreading Brood.' 2. *Spare Combs.* Yes, you may give them to a swarm with advantage.

MONA.—1. *George.*—Gorse, furze, or whin, is a good bee-flower, more useful, perhaps, for its pollen than its honey. 2. *Hawthorn.*—The bees collect from the hawthorn-bloom also, and its nectar is of peculiarly fine quality. 3. *Aspect.*—In Douglas Bay, which we know well, we should certainly prefer a south-easterly aspect, with shelter from E. round by N. to W.

F. F. MCKENZIE.—*Mouldy Combs.*—Keep your combs in a dry warm place—a closet is best—and when given to the bees they will quickly cleanse them.

F. C. W., *Southampton.*—1. *Smoke.*—You can ascertain the amount of stores by just raising the quilt and noticing if the bees are at the top or bottom of the combs. If at the top the cells on which they are clustered are empty, or being emptied. Those combs not covered by the bees you can see whether full or empty. You do not need smoke for this slight examination. 2. *Amount of Stores.* If well supplied, where is the need to give candy? It is too early yet to begin stimulating, but when you do so give them syrup. 3. *Aged Bees.*—The bees which fall are aged and worn out, and have not sufficient vitality to stand the chilly wind. 4. *Examining Hives.*—Not if you are quick about it. Hold the frames over the hive so that any bees which drop may fall into it.

W. J. K., *Firshy.*—*Ripening Honey.*—In order to thoroughly evaporate water from honey, it should be brought up to a temperature of about 200° Fahr. We cannot answer your question as to time required in ripening from experience; but should think several hours would be required, with occasional stirring.

E. C. LAMBER.—1. *Pea-flour.*—You can get pea-flour at most corn-chandlers; you ought not to pay more than 5d. or 6d. per lb. It is generally sold in packets at 1d. and 2d. each. 2. *Feeding.*—Both the feeders you name are suitable. 3. *Excluder-zinc.*—Excluder-zinc should be of such a size hole as to exclude the queen, but permit workers to pass; and if you leave a way round it, it will no longer exclude the queen, and will be useless. 4. *Arrangement of Frames.*—Yes, the arrangement of the frames across the entrance is preferable to the other. 5. *Separators.*—Any veneer, if thin, will do for separators, except woods with a strong odour, such as cedar, &c. 6. *Sections.*—Yes, the only alteration would be in the size.

N. PHILLIS, *Allbourne.*—*Weak Stock.*—Please refer to reply to C. Poland. Your case is similar.

BOZ, *Cork.*—1. *Stored Pollen.*—When the bees have increased in numbers sufficiently to well cover the frames which they already have, you may add those removed in autumn one at a time. Or, if in need of stores, exchange one containing honey and pollen for an

empty one. Owing to the mildness of the season, there are many sources from which bees are now obtaining pollen. 2. *Tussilago.*—*Tussilago fragrans* has some merits which entitle it to the consideration of bee-keepers; it grows wild in damp, waste places, and flowers abundantly, with a pleasant scent, very early in the year, before the crocus comes into bloom. Bees are often to be seen busy on the flowers of the *Tussilago* when no other plants were flowering. Mr. Ingram, a high authority on bee flora, says of it: 'As a plant which produces very early flowers, and may be grown in any wild and unconsidered spot, the *Tussilago* may be mentioned.' *T. farfara* (colts-foot) is the only British species. *T. fragrans* is a species imported from the south of France; is it possible that it is the former which is troubling our correspondent? 3. *Bee Flora.*—We have already complied with your suggestion as to bee flora, and would recommend you to procure No. 116 of the *Journal* from our publishers.

A SUBSCRIBER, *Carlisle.*—*Dark Pollen.*—The dark green pollen (propolis?) is, we think, gathered from pines, or fir-trees, of various kinds. These are frequently infested by aphides from which the bees collect very dark-coloured and unwholesome honey, lusciously sweet, but by no means pleasant in flavour.

SUBSCRIBER, *Etthard.*—1. *Wintering in Glass Hives.*—It is quite possible to winter bees in glass hives; we have done so ourselves, but never satisfactorily, for reasons previously stated. Your colony is suffering from dysentery, induced, probably, by the disturbance caused by uniting. You might, by removing the hive into a moderately warm room, cleanse the combs, frames and bees into a dry, clean hive, as quickly as possible, giving a comb or two of sealed honey on the outside of the cluster, merely unscaling a few cells near the bees, and return the colony to its accustomed stand. If the operation is long in hand the warmth will cause the bees to fly, and loss will result. A clean, dry floor-board and quilts should be given also. 2. *Nucleus Hives.*—To describe the 'nucleus system' would occupy too much space. You will find it explained in our former pages, and in all the modern books, notably in Mr. Cowan's. 3. *Wasps.*—Wasps were more numerous last season than we ever remember them in an experience of forty years, and more destructive to the bees. Nevertheless where colonies were kept strong, and entrances protected, no loss resulted. In our own apiary of forty hives we suffered no loss, although the hives were beset from morn till night. Even on Christmas-day we detected wasps trying to gain an entrance to our hives. 4. *Single Queens and Nuclei in Winter.*—You cannot keep single queens, nor even 'nuclei' without uniting through the winter. Read Cook's *Manual of the Apiary* and Cowan's *British Bee-keepers' Guide*.

**BEE-KEEPERS' GUIDE; OR, MANUAL OF THE APICARY.** 10,000 sold since 1876. Eleventh Thousand and 191 elegant illustrations. Hundreds of copies of this work have been sold in England, and the many improvements will make it even more popular in Great Britain and on the Continent. Price by mail, \$1.25. Liberal discount made to Dealers and to Clubs. Address A. J. Cook, Lansing, Michigan, U.S. Author and Publisher.

State Agricultural College, Nov. 10, 1883.

**SECTIONS, FOUNDATION, SMOKERS,** can now be sent by Parcels Post to any part of the United Kingdom, as follows, for cash with order:—  
Foundation (best rolled), 3 lb. 2/6, 2 lb. 6/6, 1 lb. 10/6, 6 lb. 13/6. Sections, 50, 2 3/4; 100 4/6.  
Bingham Pattern Smokers, 4 6 each.

**W. HOLLANDS, Harrison Rise, Croydon.**  
*Sole Makers of the famous pattern CHESHIRE HIVE.*

Special Prepaid Advertisements.

For Sales and Purchases of Bee Appliances, Honey, Books, Pamphlets, Diagrams, &c., Exchanges and Situations.

Terms: Twelve words and under, Fourpence; for every additional three words, One Penny extra; no extra charge for the words for continuous insertion.

Advertisements will not be received for insertion under this heading from Manufacturers or Dealers in Bee-Furniture, except for the Sales of Honey and Bee-Literature.

2d SPECIAL NOTICE. We cannot under any circumstances be responsible for the truth of statements made in Advertisements, or for the trustworthiness of either Buyers or Sellers.

THE SIMMINS' METHOD OF DIRECT INTRODUCTION. Enlarged to 32 pages. Price 6d. 1 copy 1s. of the Author, Nottingham, Brighton; Messrs. Nisbet & Co., 119 Beaufort Street; and Mr. J. H. Neal, 8, 22, Langley, Herts.

LEONANTHES DOUGLASSI. Plants 1/6 per 100, or 1s. per 1000. Address J. G. COLE, Fairfield, Gloucestershire.

ENGLISH and Lullman Bee-frame Hives for Sale; also several New Bee-frame Hives for 15 in., 10 in. deep, to be sold cheap. Apply T. HUNT, Southlands, Cannock Road, near Wolverhampton.

A FEW Strongly Stocked Hives Wanted by Reuben Twinstead, Sulbory, Suffolk.

OWING to the malicious destruction of my Bees, have about 5 first-class Standard Hives, also some made Extractor for Sale. Will take May Swarms, or Honey, in exchange for several. W. T. GIBSON, 42 Sharkey Street, Sheffield.

WILL some one kindly lend me Vol. II. of the British Bee Journal, or the number containing the Index to that Vol., for a few days? Address C. N. WATTS, Hon. Sec. Hunts B. K. A., Somersham.

EDUCATIONAL.—Quantity useful Essays and Copy Books. Sale or exchange. Want of German and American Bee Journal. Address C. W. ALBRIGHT, Sarnesley.

WINTER LECTURES.

For sale by

ASHTONIAN SLIDES and other objects. For further Particulars apply to

ABBOTT BROS., Southall, Middlesex.

AGENTS FOR BEE-KEEPERS' SUPPLIES.

WANTED. Two or three energetic Men in every County to undertake AGENTS for the SALE of BEE-KEEPERS' SUPPLIES of the highest class. A rare opportunity for men having spare time and an acquaintance with Bee-keepers. Liberal remuneration. For terms and full particulars apply to ALFRED H. HAYNS, 125 Bond-street, London, E. (54)

METAL ENDS FOR FRAMES.

NOTICE.—We beg to call the attention of all Bee-keepers to our latest improvement in Metal Ends for Frames, which entirely supersede the use of Zinc Runners and Broad-shouldered Frames, while their weight and fixing keep the Frames perfectly perpendicular.

Price, 10d. per doz., 9s. per gross. Specimen sent on receipt of 10s. per gross. All Hives these ends, each are fitted with the End.

Illustrated Catalogue in possession of all Beekeepers. Silver Medal, Knightsbridge, 1883. First and Second Prizes at Hamburg, 1884, &c.

C. G. HARRISON & CO., Hive Makers and Dealers in all Apianian Appliances, HALESOWEN, WORCESTERSHIRE. 1779



**HOGES' FOREHOUND HONEY**



For Sale, See Price, Prospectus, &c., Testimonial from the World's Fair, London, 1883. It is the only Honey in the world that I consider genuine. It is a most wonderful remedy. I have ever tried it, possessing properties which are not to be found in any other Honey for the cure of ailments of the Throat and Lungs.

Solely of JOHN BIRN NATIONSON, 11, Abchurch Lane, London, E.C. 4. Wholesale and Retail.

Of all Chemists.

THOMAS B. BLOW, WELWYN, HERTS.

Manufacturer of Bee-keeping Appliances of every Description, AND IMPORTER OF FOREIGN BEES.

BEGS to call attention to the unrivalled quality of his productions. All the appliances produced by machinery, bees can be used to moderate prices with high quality. Merit of his products is not only maintained as accurate fit and finish, all goods being adapted both for the convenience of the Bee-keeper in the use of manipulation to the Bee-keeper.

PRICE LISTS FREE ON APPLICATION.

THE HEREFORDSHIRE SCHOOL OF APICULTURE

SUPPLY BEES, HIVES, and everything pertaining to Modern Bee-culture. HIVES made only of the best well-seasoned wood, a quantity of which is always kept on hand and can be put together. Awarded Honorary Medal for a Hive exhibited at the International Exhibition, 1883, and First Prize at various County Shows. Began on Cardigan in 1884.

J. R. W. HOLE,

Leadbury, Tarrington, Leicestershire.

Address TARRINGTON, LEDBURY.

CHARLES T. OVERTON,

Leadbury, Tarrington, Leicestershire.

THREE BRIGGS, SUSSEX,

Bees and all the appliances for Bee-keeping. NEW STOCK OF BEE-KEEPING APPLIANCES for 1884.

Illustrated Catalogue in possession of all Beekeepers. Silver Medal, Knightsbridge, 1883. First and Second Prizes at Hamburg, 1884, &c.

SPECIALITIES.

The "CROWN HIVE," and 1st class English Smoker, the best in use; superior Honey Bees, and Good Foundation, American 20 and 14 1/2 Section; FLAT TOP STRAW HIVES, with hole in top for forcing and supering, 20 and 14 1/2 of 18 1/2 Section for Straw Hives, &c., &c., &c.

Questions on Bees and the Management of a well-kept colony of 100, 40, 20, or 10 Bees, sent for 10s. per gross. For further Particulars apply to

THE BEST BEE FEEDER for Autumn use is BUTTS' NEW FEEDER, made of White Stone China, the merits of which were fully described by the Editor of this Journal in the issue of June 1st, p. 43. Among other advantages, this Feeder is so constructed as to admit of the Bees feeding readily, and with perfect safety; and the loss of heat to the Hive (a fault common to many Bee Feeders) is entirely obviated. Being made of white ware it can be more easily cleaned than either zinc or tin, and keep the food sweeter and healthier, and cannot rust. This Feeder has been tried by many experienced Bee-keepers and Experts and pronounced perfect. Sent post free to any address for 3s. 6d. Trade price on application. EDWARD J. BUTT, Manufacturer of Bar-frame Hives and Apianian Appliances, Scotland House, Barn-stable. (12)

THIRD THOUSAND.

At all Railway Bookstalls, Booksellers, and Hive-makers.

Large crown 8vo. toned paper. 144 pp. Illustrated wrapper, 27 Illustrations, 1s. 6d.; postage 2d. extra.

## BEE-KEEPING; Plain and Practical: HOW TO MAKE IT PAY.

By ALFRED RUSBRIDGE.

LONDON: E. W. ALLEN, 4 AVE MARIA LANE.

### OPINIONS OF THE PRESS.

All his observations are founded in truth and common sense, and all his proposals are of a thoroughly practical nature. The man who intends to keep bees profitably, and to put all toy systems out of sight, can do no better, in the first instance, than invest 1s. 6d. in Rusbridge's Bee-keeping. — *The Gardener's Magazine*.

Ably and cheerily written . . . Those who wish to go into the interesting speculation are not likely to find a wiser counsellor than our author. — *The Western Times*.

In which the most advanced methods of apiarists are carefully explained. Rustic prejudices, born of ignorance, are heartily laughed at, and the best systems of procedure clearly set forth. — *Daily Chronicle*.

Bee-keepers who wish to make money, and gather honey by the hundredweight, should get the book and be guided by it. — *The Western Morning News*.

Clearly printed on good paper, written in a plain chatty style, and contains many illustrations. — *Journal of Horticulture*.

The author is a well-known apiarian, and this cheap little book is well timed . . . We cordially recommend Mr. Rusbridge's book. — *Horticulture's Science Gossip*.

The low price at which the book is published brings it within the reach of all, and we confidently recommend it. — *West Sussex Gazette*.

The book . . . should be in the possession of everybody who desires to become a practical and skilled apiarian. — *Derbyshire Advertiser*.

Mr. R. goes thoroughly into every part of the subject, and explains it in a plain and chatty style, which makes what he has to say agreeable as well as instructive. . . . The book is essentially practical throughout, and whether a person wishes to take up bee-keeping as a "hobby," or with a view to profit, or with both objects combined, he can hardly have a better guide than Mr. R. in his "Plain and Practical Bee-keeping." — *Gloucester Journal*.

This is a useful and valuable little book.

*The Cambridge Express*.

Well printed, well illustrated, and well written. . . . Interesting even to such as cannot keep bees. — *Isle of Wight Advertiser*.

*Isle of Wight Advertiser*.

Mr. R. is not a new aspirant for literary honours. . . . Apiculturists is not a wish to combine pleasure with profit should study the author's instructions. How to make it pay. — *The Paper and Printing Trade's Journal*.

Those who contemplate keeping bees, as well as those who already do so, cannot have a better qualified guide than Mr. R., nor a better handbook than that which he has just written. . . . Even those who do not keep bees, and never intend to do so, will find much to interest them in these pages: for, besides his instructions about the management of bees, Mr. R. treats of them from a natural-history point of view, and also gives a chapter on rustic superstitions about bees which is very amusing. — *Brighton Herald*.

An interesting work, full of information, and worthy the notice of all persons engaged in bee-culture.

*The Grantham Journal*.

For Review in this *Journal*, *vid.* issue June 1, 1883.

For Contents, see May No., 1883. (56)

FOR FINEST IMPORTED QUEENS, see Jan. No., page 20. FRANK BENTON, Munich, Germany.

NEW ILLUSTRATED CATALOGUE of HIVES, &c., just out, Gratis, and Post free. Address G. STOTHARD, Welwyn, Herts. 1786

BARGAIN, Two HIVES, 10s. each, original price, 15s., Standard Frames, 16 in. Top bar, saw-cut. New Frames, never used, well painted, Address E. JACKSON, The Grange, Welwyn, Herts. 1781

CHINA HONEY BOXES and JARS, as sold at the Knightsbridge Show, may be obtained of Mr. J. HURDLE, King's Langley. The Boxes are suitable in size for holding 1 lb. Sections, and the Jars about 1 1/2 lbs. of Extracted Honey, both are very ornamental and convenient for the Breakfast Table. Price reduced to, Boxes 2 6. Jars 1 0. Can be forwarded by Parcels post on payment of the cost of carriage, amounting to 6d. for one Box; two Boxes, 9d.

### Bee-keeping as a Business.

STUDENTS are accepted at any time at the GREAT SUSSEX BEE FARMS on reasonable terms. Almost anyone can keep Bees; but it is a fact that not one in fifty will ever make it a profitable business unless Practical Lessons are taken for at least one Season on a large Bee Farm, conducted on modern principles. Without such instruction, it takes years to acquire the knowledge necessary to ensure success in this most fascinating and health-giving pursuit.

As the Proprietor devotes his time entirely to the production and sale of Honey and Bees, those studying with him will have his undivided attention, and will be qualified to start out at once on a recognised system of management; thus saving much needless expense and labour conducted in a wrong direction. Particulars on application to S. SIMMS, Proprietor, Great Sussex Apiaries, Rottingdean, Brighton. (47)

Bronze Medal awarded for Show, Skaps at the Great Crystal Palace Show, 1875.

Seventeenth Edition. Price One Shilling.

### SEVENTY POUNDS A-YEAR: HOW I MAKE IT BY MY BEES.

By the late J. W. PAGDEN.

Also, by the same Author, price Sixpence.

### EARLY ARTIFICIAL BEE-SWARMING.

No watching required.

Apply to Mrs. J. W. PAGDEN, The Chestnuts, Alfriston, Sussex, by whom the same manufacturers of 'Economical Bee Furniture' are employed as formerly. (40)

### Imported Cyprians & Syrians.

THE undersigned will visit Cyprus and Syria this Winter, and bring back full Colonies and Nuclei, with only selected Queens, part of which will be raised by himself in March. Fine Queen sent before June 1st, 22s.; during June July, or August, 20s.; after September 1st, 18s. These are to be Selected Queens of fine grade. A limited number of exceptionally prolific Queens can be supplied at an additional price of 5s. each.

### Imported Carniolans & Italians.

Fine Queen before June 1st, 24s.; Extra Fine, 12s.; during June, 8s.; Extra Fine, 10s. I accept and send out none but Choice Queens. The very choicest Selected Queens are those denoted above as 'Extra Fine.'

Any Six Queens, 5% off; Ten Queens, 10% off.

Carriage prepaid. Safe arrival guaranteed.

FRANK BENTON, Georgan St. 8, Munich, Germany. (50)



# THE BRITISH BEE JOURNAL

Communications to the Editor to be addressed 'SILANGWAYS' PRINTING OFFICE, TOWER STREET, ST. MARTIN'S LANE, W.C.'

[No. 140. VOL. XII.]

FEBRUARY 15, 1884.

[PUBLISHED FORTNIGHTLY.]

## Editorial, Notices, &c.

### INTERNATIONAL HEALTH EXHIBITION.

The Sub-Committee of the British Bee-Keepers' Association have applied to the Executive Council for leave to present at the forthcoming International Health Exhibition a collective and comprehensive exhibition of the honey industry of the United Kingdom, and they desire that it should include—

1. Hives of bees at work (behind protecting screens of glass).
2. A show of pure honey (to be supplied in the first instance from the best samples of last season's honey, and to be replaced from time to time by fresh produce of the season of 1884).
3. Specimens of the most approved hives and apparatus for harvesting honey.
4. Specimens of the implements employed in modern bee-keeping.
5. Objects illustrative of the natural history of the honey bee and its kindred varieties and of bee flora.
6. The means of detecting adulterated or spurious honey, with analyses of impure or manufactured honey now sold in the markets.
7. The beverages in which honey forms an important constituent, with the recipes for making them.
8. The delivery of one or more lectures in connexion with the development of honey production of the British Isles and the best means of extending it.

The Committee inform the Executive Council that they have, through the organization of their affiliated County Associations, the fullest communications with the dealers and producers throughout the country, and that therefore they would be enabled to secure a full and representative view of the subject.

In order to make a proper exhibit of the whole subject, the Committee would desire to have an area space of 10 feet by 80 feet, so situated that the working bees could have flight to the open air.

As the honey exhibited would after a time be subject to depreciation in value, the Committee would desire to have liberty to sell it in small quantities on the premises, subject to the due maintenance of a full display of each kind during the exhibition.

The Committee have also applied for liberty to sell their publications, diagrams, &c., and to advertise them and their other exhibits by the issue of handbills.

### BEEHIVE COMPETITION.

Kindly allow me a few words on this subject. The object, if I understand it aright, is to get at the cottager, and to teach him how to improve his condition by a profitable culture of bees. Now are we likely to accomplish this laudable desire by attempting, at the very beginning, to launch him into all the more occult and difficult operations of the art of modern bee-culture, such as queen rearing in nuclei, queen-introduction—for profit from the sale of queens implies all this—artificial swarming, by dividing and by other means—since competition by sale of swarms implies this also—and all the thousand and one scientific methods of practising the art! In the late competition, by admitting into the balance-sheets such items as sale or purchase of queens, swarms, bees by weight, &c., &c., all this is implied without doubt. No, Sir, we must teach 'Hodge' to walk before we can expect him to fly.

It seems, therefore, to me that the only legitimate source of profit to be allowed in this competition, for the present at least, should be derived alone from the sale of comb-honey and extracted. Teach him the use of an improved skep, of the Stewarton hive also, or any other storifying hive, if you will, and, above all, teach him the use and the advantages of the *simplest form* of the frame-hive which admits of doubling for procuring the largest amount of extracted honey—such, for instance, as the one so well described by Mr. Simmins in your issue of Jan. 15th—and from which may be obtained comb-honey also in its greatest perfection and most saleable form, and you will be doing that at which you aim, and performing an excellent and really charitable work.

The work, I know, is beset with difficulties, such as the wide area of many of our County Associations, and their lack of qualified experts, their work being already beyond their powers; all of which entails the necessity of a well-digested code of rules. But if the production of honey be the only allowed source of profit, the matter becomes at once simplified. The one difficulty then would be the price at which the produce is sold, which, no doubt, must be according to quality, but must not be left to the award of the competitor himself, nor to the officials of his County Association. Could not the Central Association decide this point by

undertaking the sale of all the honey produced by competitors, without loss accruing to itself? I merely wish to throw out these suggestions, so pray take them for what they are worth. I certainly have the feeling that the managers of the late competition were drawn into sanctioning many items in the balance-sheets which were never contemplated by the originators and manipulators of the scheme.—GEORGE RAYNOR, *Hazleleigh Rectory, Feb. 9th, 1884.*

#### COUNTY ASSOCIATIONS.

Reports of several County Associations for the past year are to hand. We purpose giving a statement of the number of Members of each Association. The following is the list already received:—

ASSOCIATION.	MEMBERS.	ASSOCIATION.	MEMBERS.
Buckinghamshire ..	238	Kent .. ..	300
Brecon .. ..	72	Leicestershire ..	127
Cornwall .. ..	103	Norfolk .. ..	234
Derbyshire .. ..	170	Shropshire .. ..	52
Dorsetshire .. ..	177	Somerset .. ..	97
East of Scotland ..	144	Staffordshire ..	112
Essex .. ..	186	Sussex .. ..	301
Herefordshire ..	112	Worcestershire ..	173
Hertfordshire ..	295	Yorkshire .. ..	95
Huntingdonshire ..	60		

#### BEE FLOWERS.

In a recent article on Bee Flowers I named a comparatively small number of useful and easily cultivated annuals and perennials, believing that it is not so much in variety as in the greater extension of the special flowers known and recognised as good bee flowers. I also thought it desirable to suggest the names of those plants from which results would be obtained by sowing and planting early in the spring during the first year, and in almost any little piece of garden ground. The list would be greatly extended by indicating the plants which are usually visited by, and are profitable to, bees; and although I will not so much extend it by enumerating all that I have thus noted, there are still some that should not be omitted in any collection of bee flowers, and the value of some of them is in blooming either at a moment when other flowers have not appeared, or successively and after the early summer and the best pasturage have passed away. A plant of easy culture, and perfectly hardy and amongst the first to bloom in the spring, indeed it is now budding, is the blue Lungwort—*Pulmonaria azurea*; it belongs to the Borage family, one of known value in the bee flora.

I did not name an annual or biennial, *Mullein*, *Verbascum phoeniceum*, in my first list, but it is a very pretty garden flower, and one much visited. It goes on blooming throughout the summer if sown at two or three periods. Most, if not all, of the Cruciferous plants are sought out by bees; one of the bitter cresses, *Cardamine rotundifolia*, even at this moment in bloom, is well worth cultivating. Although too late for sowing *Limnanthes*, it may still be planted; those who once possess it are not likely to lose it, as it seeds largely and springs up in myriads for another year. The deciduous shrub

called *Snowberry*—I will not disgust some of your susceptible readers by inscribing its very long name—produces small sweet blossoms, which are regularly investigated by the honey bee; it is a shrub that will grow anywhere, and its white berries are useful for winter decorative purposes. I was tempted to grow what is known as *Canada Balsam* last season; it had great attractions for humble bees, but I do not think it was ever visited by the more profitable occupants of our hives, and I do not recommend it. The advisability of extending the cultivation of fruit trees, and thus to save to the country the money now expended on the purchase of fruit produced by foreign growers, is pretty generally admitted, and it is a course that should be sanctioned, practised, and encouraged by bee-keepers; for apples, cherries, plums, and peaches, in all their varieties, afford good supplies both of nectar and pollen to bees; and gooseberries and currants are not without their value, and bees return the good they gain by setting the blossoms of the fruit they visit. The raspberry is pre-eminently valuable to bee-keepers, and should be encouraged in every direction. While in bloom bees neglect the more brilliant and tempting flowers to visit the obscure and colourless raspberry blossom.—W. INGRAM, *Belvoir, Feb. 9th, 1884.*

#### HARRISON'S REMOVEABLE METAL ENDS.

The Committee of the B. B. K. A., when determining the dimensions of the Standard Frame, did not recommend to bee-keepers, any special method of keeping the distances between the frames. Some experienced bee-keepers by the education of the eye and through much practice, are able to dispense with all supplementary aid. But as  $1\frac{1}{2}$  is a very fine fraction, and great precision being the rule in hives, a variety of methods have been invented to assist the less-practised beekeepers. Distance-pins and staples are rapidly giving way to broad shoulders and removeable metal ends. 'Dr. Pine' was first in the field with his metal ends for frames having an open top; then came Mr. Blow's, with the top closed in. We have received, from Messrs. Harrison, of Halesowen, Worcestershire, samples of their metal ends, which are modifications of the preceding. They are firm and strong, and well adapted to their purpose; and when the ends of the top bars are inserted in the rectangle the lateral and the longitudinal distances are kept without a possibility of derangement.

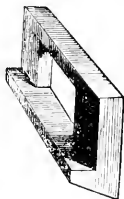

#### AMONGST THE SWISS BEE-KEEPERS.

##### No. VII.

When I was invited by M. Bertrand to accompany him to Zurich to visit the Exhibition there, one of the inducements held out to me was a visit to see the apiary of M. J. Jeker at Subingen, which was but a very little out of our way. Having heard a great deal of this gentleman I was anxious to see his apiary, especially as I was told that it was a model of the German-Swiss sys-

tem of bee-keeping. All arrangements being made I left Montreux one morning in September at about six o'clock; and at Lausanne station, where the line branches off, I met M. Bertrand and M. G. de Layens, who had come from Nyon to meet me there. We then continued our journey together, taking the train from Lausanne, by Yverdon, Neuchâtel, Biemme, and Solenne, to Sullingen. The journey was a long one, taking eight hours; but it was a very pleasant one, the scenery being varied, and always charming; the weather everything that could be desired, and my companions agreeable and chatty. I need hardly say that our principal conversation was about bees, and this subject we certainly failed to exhaust. After leaving Lausanne we lost sight of the Lake Lemano, and passing through some green and pleasant valleys, and then through a couple of short tunnels, the train proceeded, amidst a fertile and thriving country, along the valley of the Thièle, with fine views of the Jura Mountains, and often a view of snow-peaks, which we were now fast leaving behind us. About an hour and a half brought us to Yverdon at the lower end of the Lake of Neuchâtel, and from here the railway skirts the lake as far as the town of Neuchâtel. To the north are the Jura Mountains,

a long chain forming the north-west boundary of Switzerland, and stretching from the Canton Valais to the Canton Aargau. The scenery of the lake is not quite as interesting as some of the other Swiss lakes, and the landscape is composed of undulating country; hills tinted with woods, amongst which are villages; picturesque masses of bare rock projecting at intervals; fertile meadows, which by copious irrigation produce their three crops of grass a-year, presenting a carpet of the liveliest verdure, and nourishing myriads of honey-yielding plants. The frequent hedge-rows and gardens before the cottages remind one frequently of England. The principal produce of the Canton of Neuchâtel is wine, vineyards covering the southern slope of the Jura. Neuchâtel is itself built upon the steep slope of the Jura Mountains, and along a narrow slip of ground between the mountains and the lake. The entire southern slope of the Jura, a limestone formation, is strewn with granitic blocks, which have been derived from the high Alps, and are supposed to have been transported there by the agency of glaciers at a period when these covered a large portion of Switzerland. From Neuchâtel the train passed along the shores of the Lake of Biemme, whose banks are neither bold nor striking, although it possesses much quaint beauty of scenery. This lake as well as that of Neuchâtel have been much spoiled by being lowered, the receding waters having left ugly strands of gravel incapable of cultivation. It is hard to imagine how a people, for the sake of a small gain,

could submit to have these lakes thus disfigured. From Biemme half-an-hour's journey brought us to Solenne, the capital of the canton of that name, and prettily situated on the Aar, at the foot of the Jura range. At this place we changed trains, and in about a quarter of an hour reached Sullingen, where at the station we were met and welcomed by M. Jeker, who conducted us to his residence, a quiet parsonage-house about the centre of the village.

After spending eight hours on the journey we were ready for a wash and brush-up, and then joined our host at lunch. Here we were introduced to M. Jeker's mother and sister, who both not only take an interest in bees, but do much of the work of extracting the honey and looking after the bees. M. Jeker is the parson of the village, and the authority on bees, devoting part of his time to the care of his flock, and the rest to the care of his bees, and neglecting neither the one nor the other.

One could not be long in his society without feeling that to know him was to appreciate him, his remarks being always full of good humour, and at the same time of sound practical sense.

After lunch we followed him to his garden to see the bees, and here we saw an apiary, consisting of about eighty colonies, all in splendid order. By

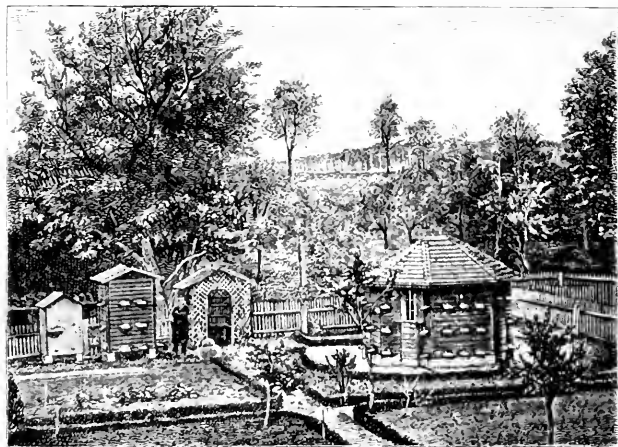

referring to the engraving it will be seen how well the apiary is situated. Sheltered from the north by trees and a forest in the distance stand three pavilions, of which the largest, that on the right-hand side of the engraving, contains fifty-one hives. The pavilion is built in the shape of a federal cross, there being three rows of five hives in the front and two sides, the fourth side of the cross being occupied by the entrance doors, on each side of which are three hives. In the angles are windows closed by shutters inside, and there is also a window in the top for the purpose of giving light and ventilation. The doors at the entrance have also glass let into them, and all these windows are so contrived that they can be reversed at any time to allow any bees flying against them from the inside to escape. Inside is a chamber, large enough to contain several persons, and into this chamber all the hives open. Each hive is provided with a separate door, and on these doors are fixed in frames the photographs of various beekeepers. The hive here used is of the German pattern, improved by M. Jeker, and called the 'Burki-Jeker' hive. It is hardly necessary to say here though what different modifications the hive went through before it reached its present form. Suffice it to say, that as now modified by M. Jeker it has received the approval of most of the members of the Swiss Beekeepers' Society, so that it may be taken as a type of the hive in use in the German-speaking cantons of Switzerland.

The inside dimensions of the hive are 24½ in. high, 11½ in. wide, and 17¾ deep, and contains thirteen frames. It is also provided with a division-board, into which is let in a piece of glass. The frames are made one inch wide, and are kept the proper distance apart by distance-pins placed nearly at the ends of the bars at top and bottom on alternate sides, so that the frames can be turned round as occasion may require. There are three different sizes of frames in these hives, the largest being 18½ in. by 10½ in. inside measure; the smallest, 10½ in. by 5½ in.; and the medium size 10½ in. by 8½ in., all inside measure. The larger frames being used for the brood chamber, and the smaller ones for honey, and are placed on the top.

M. Jeker uses six or seven of the large-st frames for strong stocks, and fills up the hive with the medium and small-size ones. For small colonies he finds the medium and small sizes sufficient, and they can be built up, gradually introducing the larger ones. The frames are introduced from the back of the hive, and are drawn out by means of pieces made for the purpose. When the small frames are not used above the larger ones the space is shut off by means of slips of wood which are placed on the tops of the lower frames forming a roof to the hive, and in winter a chaff cushion is placed on this, and allowed to hang over the division-board. There is a considerable space left between the bottom of the frame and the floor-board, and this is for allowing the accumulated rubbish to be easily raked out by means of a rake made for this purpose.

In the division-board is a small opening at the bottom for introducing a feeder, and all the bees are fed from the inside of the pavilion. The whole thing is very compact, and its advantages are, that it occupies a very small space, that the bees help to keep each other warm in winter, that operations may be performed at all times inside, even during rainy weather, that the operator is less liable to being stung, and danger of robbing whilst operating is obviated. Bees are also said to consume less food during winter, and feeding can be rapidly performed.

On the other hand, the disadvantages are very great, and examining one of these hives is much more troublesome than one opening at the top. Changing the position of the colonies in making artificial swarms, and such-like operations, are much more troublesome, the chances of losing queens from such a close proximity of the entrances is also very great, although this is, to a certain extent, overcome by having the fronts painted different colours. Ventilation is difficult, and in case of foul brood its eradication would be most troublesome.

All these disadvantages disappear when the hives are each on a separate stand, but in this case those with a small space at their command would have to be content with fewer hives. M. Jeker, however, is of opinion that where plenty of space is available hives opening at the top are preferable. A little to the left, in the engraving, standing by a summer-house, is M. Jeker himself, watching intently the bees flying in and out of the entrances of a smaller pavilion containing twelve hives; and further to the left, is a still smaller one, containing only four hives. These two last have no chambers behind them, and have only doors, so that the bees may be locked up as in a cupboard, but otherwise they are similar in construction to the larger one; they are also neatly ornamented, the roofs being covered with the small wooden shingles used so extensively in this part of the country for protecting the outer walls of the houses from the weather. Standing at M. Jeker's feet is one of the large straw hives and cap used by those who do not believe in frame-hives. Besides the hives seen in the engraving there are a number of others, some under a cover to the left, and several single hives placed here and there in the garden.

One of the hives was on a weighing machine, so that its owner was able to register the daily income and expenditure. We were also shown several improvements in apparatus made by M. Jeker, one of which was a double

pipe for smoking bees, similar to, but an improvement on, that figured in Dzierzon's *Rational Bee-keeping*; also a hive with the side walls extended upwards, as some hives used by us, and where frames can be manipulated in windy weather without chilling the brood.—THOS. W. COWAN.

## RUDIMENTS OF BEE-KEEPING.

### THE HIVE AND ITS CONTENTS.

Now that 'our bees' should be keeping as quiet as we can induce them to, by carefully shading the entrances to our hives, the novice in bee-keeping must not be tempted impatiently to disturb or open his hives until warmer spring weather makes it safe to do so. After satisfying himself that his hive is well provided with food sufficient to last until honey can again be gathered, he should use the present season of repose as a time for becoming more familiar with the habits of his bees, and the necessary conditions under which they need to be kept. He will find such information in the numerous books published on bee-keeping.

The hive is a chamber in which the bees make their home, and should be warm, dry, and free from draught. Its size and shape outside may vary, according to the fancy of its owner, although care must be taken that it is neither too small nor too large for its occupants' requirements. Different districts require hives of varying size, according as the honey-yield in the neighbourhood is generally large or small.

As a rule, a medium-sized hive is the best, if you are in any doubt. Moveable comb hives, provided they are large enough for ordinary summer requirements, can at other seasons be reduced in size by dummies when a smaller brood-chamber is desirable. On the ground of expense, hives larger than we are likely to need should not be used. It is most important that the frames in all moveable comb-hives should be exactly of one size, so that they can be used in any hive desired. If this is not the case, the operations of the bee-keeper will be greatly hindered.

In this warm, dry chamber-hive a great number of insects, usually in seeming perfect harmony, all possessing a common mother, the queen, and all working for the welfare of the whole community. In our hives, at the present time (Feb.) we should only find the queen surrounded by her worker subjects, but in summer we shall find in them a third kind of occupant, the drone. The queen's principal duty is to lay the eggs, from which are hatched the succeeding generations of bees. Since incessant work soon weakens, injures, and destroys the worker-bees at the busy time of the year, it is absolutely necessary for success to have in your hive a vigorous, young queen, able to lay a sufficient number of eggs to maintain the colony in a strong condition, full of bees. Each queen's age should be noted, and when she is getting old, and shows signs of failing in her powers of laying, we should replace her by a young queen. The method of doing this will be explained in the course of time in 'Rudiments.' It is described at length in Cowan's *Guide*, p. 115.

The eggs once laid by the queen require the worker's care to bring them to maturity. Food must be provided for the grub's support, both honey and pollen, properly prepared. Water, too, is necessary for the well-being of the hive. When the breeding-season commences all these elements are usually found inside the hive, honey and pollen in the cells, stored ready for use, and moisture, which more or less is to be found in the interior of even the most water-tight hive. It must not, however, be supposed, from water being required to prepare food for the brood, that damp hives are not injurious. The hive should be kept externally as water-tight as possible, and full of bees, to prevent undue condensation of water inside it. Should the bees require more water than the

interior of the hive naturally affords, they will procure it out-side.

By the use of these three essentials, honey, pollen, water, the workers prepare the food for the brood. It is also the workers' task to maintain in the hive the temperature needed to mature the young grubs. Heat is generated in the bee's body, and if increased warmth is required an increased amount of food is consumed to produce it. More heat is consequently generated, and this is supplemented, if required, by the movement of the wings, the exertion of which adds to the heat given off.

(To be continued.)

## ASSOCIATIONS.

### BRITISH BEE-KEEPERS' ASSOCIATION.

We beg to remind the Members that the Annual General Meeting takes place on the 20th inst. There are two very important questions set down on the agenda for discussion, viz. —

1. The formation of a metropolitan depot for the sale of honey, reading-room, and museum.
2. The adulteration of honey, and the appointment of an analyst.

The meeting will be held at 105 Jernyn Street, and the chair will be taken by the Baroness Burlett Coutts, President of the Association.

### DISCUSSION.

On Mr. S. Simmins' paper on 'A Practical Experience with Foul Brood, and How Cured.'

The Chairman, in inviting a discussion on the paper, said that the whole question had been treated in an eminently practical way quite apart from its scientific side. A recent number of the *Bee Journal* contained a report of Mr. Cowan's visit to some apiaries in Switzerland, in which it is explained how the disease is dealt with scientifically. There are two ways of dealing with it, and he hoped that those who were conversant with the subject would express their opinions as to which was the more preferable.

Mr. Baldwin thought Mr. Simmins' plain method of describing the disease of foul-brood and its features, which were pretty well known to every practical bee-keeper, was a serviceable addition to bee literature. When Mr. Simmins recommended that a watch should be kept by every bee-keeper on the condition of his neighbours' bees no doubt he suggested a very practical way of stopping the spread of the disease; but he had found many obstacles during his experience in carrying out this advice. On one occasion he knew that a neighbour had foul-brood to a bad extent, for it could positively be smelt at the entrance to the hive. On getting into conversation with the bee-keeper, he offered to examine the hives and take care of the bees if he liked. Eventually after some further talk and persuasion, he succeeded in showing that the bees were diseased. His surprise could be imagined when the bee-keeper said that this was all brought about by the new-fangled hives in the neighbourhood which were no good to anybody. He had discovered foul-brood in existence in many neighbourhoods where there was scarcely a frame-hive to be found. As regarded cottagers, his experience taught him that the only way to get rid of foul-brood with them was to purchase their stocks, for the cottagers themselves were generally too apathetic to take any measures to stamp out the disease even when assistance was proffered them. He re-

membered an occasion at Haslemere, in Surrey, where he had a bee-stand, and went in search of bees for manipulations. The gentleman on whose ground the tent stood sent his gardener to help him. On visiting some of the bee-keepers, he ascertained that for a long time they had succeeded very well; but during the last four or five years their efforts had resulted in complete failure. The cause of this was soon made apparent, for shortly after he found three or four skeps in the neighbourhood which were positively rotten. He cut out the combs and showed the disease to the owner, who had the impudence to blame the new hives in the locality for all the misfortune. Of course, the only means of curing this ignorance was by education, the importance of which he was glad to know the British Bee-keepers' Association fully recognised. He thought that not a particle of food should be given without the salicylic solution. He fully endorsed Mr. Simmins' remarks to the effect that honey should never be extracted from combs containing sealed brood. To the unpractised eye it was difficult to say what was sealed and what was unsealed brood; and he, therefore, thought it was better to recommend that honey should not be extracted at all from combs containing brood, because even in the case of unsealed brood an unskilled person would very likely displace the larva, or get the brood chilled. Mr. Cowan's plan of treatment, given in the *Guide-book*, he thought sufficient to meet all circumstances. He quite approved of the caution enjoined by Mr. Simmins respecting the necessity of disinfecting hands, gloves, smoker, and indeed every article brought into use. The slightest touch of foul-brood was sufficient to communicate the disease. Water should be used freely, and always have the salicylic solution in it. The disease was often spread in shifting the cushions or quilts from one hive to another. In winter extra cushions and quilts were used. These, perhaps, become slightly tainted without the knowledge of the owner. As the spring advanced, they were disposed of and brought out again the next autumn, of course with most unfortunate results. Quilts were cheap enough, and he recommended that if there were the slightest taint they should be destroyed.

The Rev. W. E. Burkitt was happy to say that he had seen very little of foul brood himself. The only circumstance which had ever come under his own notice happened in 1882. He was at the time doing what Mr. Baldwin and Mr. Simmins had both advised should not be done, namely, extracting honey from a comb that contained brood. The honey was particularly wanted for a show at the beginning of the next week. During the operation he upset the can in which was the capping-knife over a comb containing brood. The hot water was spilt over the comb. He thought, however, the brood would not be hurt. If any harm, however, should result he believed the bees would soon be able to repair it. Three months afterwards, in that hive he found very suspicious-looking cells, and he asked a friend to come, who soon concluded that there was a case of foul brood. He thereupon destroyed every comb that had brood, and thoroughly disinfected the old hive, washing it with salicylic acid. He gave salicylic acid liberally in the bees' food, and put them in winter quarters very much diminished, but quite healthy, apparently. However, after Christmas he found they were all dead. After this the hive was fumigated with sulphur, and purified with lime-wash. During the present autumn he had come across a few cases of incipient foul brood, in which there was no stench, and no decayed brood. The capping was sunk and the brood was dead, but the disease never advanced further than that. He destroyed all he found in that way, and used salicylic acid profusely. He had happily not encountered a single case of foul brood in cottagers' hives.

Mr. F. Zehetmayr was of opinion that salicylic acid

was not an effectual remedy in cases of foul brood. When he was a boy at home the custom was to burn the hive in which there was any taint of the disease, salicylic acid at that time being unknown. Two years ago he had a very bad experience of foul brood. On coming home from a journey he discovered it to be raging in one hive, brought about, no doubt, by making use of an old and tainted comb. He at once began to use salicylic acid, but very shortly two other hives became affected. He reduced the hives to two, burning the combs; but still it was impossible to eradicate the taint. Being loth to destroy them he tried again to save what he could, and reduced the two to one hive, of course washing and purifying it with salicylic acid, etc. However, this last effort failed like all the others, and after a month or two he was compelled to burn everything. He recommended the use of thymol as a powerful disinfectant. He had made a little machine by which he steamed the bees with this substance. It might be used in another way, namely, by placing a little bit of it in a sound hive infection was prevented, because the bees of the infected hive would not come near it. Thymol had a smell which the bees did not like, and they often carried it out and put it before the hive; but when they became accustomed to the smell the objection wore off. It was his opinion (although there might be some cases in which remedies had proved successful), that taking into consideration the risk of infection, the safest plan in all cases of foul brood was to burn comb, hive, and everything; which view was also held by a great German bee-keeper who owned at least 2000 hives. If he had followed out this advice in the first instance he would have saved two hives instead of losing all.

Mr. T. B. Blow had seen a great number of cases of foul brood in Herts., and quite agreed with Mr. Sinamins in saying that half measures employed to combat that evil were of no use at all. Instances had come under his notice in which all the combs had been removed from the bees, and the bees placed in hives on foundation, and then in the course of two or three weeks foul brood had broken out again. The only satisfactory way to deal with the evil was to remove the combs in bars, quarantine the bees for a week, and then place them in a clean hive. Of course, as had been pointed out, great care must be used in this operation to avoid the transference of taint. He recommended that a solution of thymol should be used in washing hives which needed purification, and a few lumps placed therein afterwards would certainly act as a disinfectant.

Mr. Zehetmayr was quite of Mr. Blow's opinion, and suggested that infected hives should be steamed with thymol, which would, no doubt, destroy all bacteria.

Mr. F. Lyon remarked that supposing the disease were of fungoid character there would be a large number of microscopic spores. The difficulty was to get at these. No doubt this could be best done by fumigating. He would like to know whether the vapour of sulphurous acid would destroy these germs. He himself had had no experience of foul brood.

Mr. Zehetmayr replied that the disease was of fungoid growth, but that the vapour of sulphur was not effectual. He recommended steaming with thymol.

Mr. R. G. Hinton explained that there was great difficulty in curing foul brood by means of fumes. If there were any mass of brood at all the outward portion of the mass only became affected by the fuming, which did not penetrate to the minute bacteria inside.

The Chairman believed that all bee-keepers were certain to encounter foul brood at some time or other during their experience. It would undoubtedly be a great gain if science could devise some practical means of preventing the disease, and he wished scientists would direct their attention to this subject. As to the method of dealing with it after it had developed itself, he was

very much inclined to agree with the majority who had spoken that evening. He had had very considerable trouble with foul brood, especially during his first season's experience, and he could suggest no better remedy for it than that of removing the combs, and quarantining the bees before placing them in a new hive. The success of any treatment, however, depended very much on the weather he thought, for the experience of one season was sometimes quite different to that of another. In the case of a hive of his own badly infected with foul brood, he had killed the queen at once, and left the bees to themselves to raise a queen if they liked. That seemed to answer, and as soon as a young queen was raised he drew the swarm and put them into a skep, kept them for two days, and then put them on to foundation. They amply repaid him. The stock was built up very rapidly afterwards, and the weather being fine he got a large quantity of honey from that stock of bees. If the weather had not been good, and there had been a check to breeding, the result would probably have been very different. There was no doubt that foul brood existed a good deal in cottagers' hives, where it spread contagion owing to the ignorance and apathy of the owners. One might offer them advice, but as a rule they would not trouble to carry it into practice. They were quite content to let things be as they were. Any improvements must be carried out by the person suggesting them. He had frequently been obliged to purchase stocks of cottagers, but this involved an expense that could not be continued without limit. Often as much as a guinea was demanded by cottagers for small hives. Foul brood was very often brought about by the injudicious treatment of novices in bee-keeping. The charge against what was called 'the new-fangled hives' might lie possibly in some shallow minds. No doubt if the bees were exposed too much and too often, a bad effect would result. Nobody was so fond of using the extractor as beginners. The beginner set himself up with all the gear necessary, and was not satisfied unless he was using it. The bees were thus too much exposed to draughts in all kinds of weather.

Mr. W. O'B. Glennie quite indorsed the Chairman's remarks respecting cottagers, who, when they got possession of a new hive, were constantly meddling and interfering with the bees, causing them to lead a very troubled life. He had pointed this out to cottagers, and the reply he got was, 'Well, but we cannot tell what they are doing. You made us do away with the skep, which was a sealed book.' He answered that if they did not abstain from pulling them out and looking at them so much the bees would soon die. Referring to the Chairman's remarks, he concluded that when he (Mr. Garratt) drew out his bees, and put them into a skep for two days, that he did not feed them, but acted on the starvation principle. He (the speaker) would like to know whether Mr. Garratt sprayed them in any way, because the bees themselves were apt to take the spores of foul brood on their bodies. He had found it a good plan to spray them with salicylic acid, keep them more than two days in quarantine, and put them into new hives on foundation. He had always been successful with this treatment, and was strongly in favour of spraying.

The Chairman intimated that he did spray, to a slight extent, the bees to which he had referred.

Mr. Blow did not think spraying so good as smoking or steaming, because the sprays would not find their way to every part of the bees' bodies, as would smoke or steam. Thymol was most valuable for steaming the bees while in quarantine. It was extracted from oil of thyme, and was a substance like camphor. It could not generally be obtained of a country chemist.

Mr. Zehetmayr recommended spraying with salicylic acid as well as steaming with thymol. Thymol was more antiseptic than salicylic acid. He did not put his

bees on the starvation principle. If he had treated them as Mr. Simmins recommended, perhaps they might have been saved.

Mr. F. Lyon inquired whether any one present could give any information on the subject of milk-and-egg diet for bees.

Mr. Zehetmayr said that Hilbert, a German bee-keeper, had tried it. Another German bee-keeper recommended flour and water first boiled, and then mixed with the syrup.

The Rev. T. Sissons moved a vote of thanks to Mr. Simmins for his paper. He regretted the absence of that gentleman, who was an ardent bee-keeper. His (Mr. Simmins') apiaries at Rottingdean were among the best conducted in the kingdom, and were well worthy of a visit from any bee-keeper.

The Rev. H. R. Peel seconded the motion, and wished to include therein some acknowledgment to Mr. Henderson for the ready way in which he had supplied Mr. Simmins' place. They had had a pleasant evening, and he thought the gentleman who had enlightened them so much concerning thymol could render them yet another service by contributing an interesting paper at some future meeting.

Mr. Stewart moved a vote of thanks to the Chairman, which was seconded by Mr. Drinkwater.

The Chairman returned thanks, and the meeting was brought to a close.

#### LEICESTERSHIRE BEE-KEEPERS' ASSOCIATION.

The annual meeting of the above Association was held in the Mayor's Parlour of the Old Town Hall on Saturday afternoon, under the presidency of the Rev. A. M. Rendell (Coston). There were also present the Rev. T. W. Goddard, Messrs. T. Carter, Johnson Ward, W. P. Meadows, George Byron, Billson, T. Walker, W. S. Pridmore, J. W. Bickley, J. Newham, H. Bond, Foxon, E. Redshaw, P. Wright, and E. Ball (secretary). The report was unanimously adopted, after which the following gentlemen were appointed to act as a committee:—Rev. T. W. Goddard (Hittlewell), Rev. J. Bird (Walcot), Mr. T. Carter (Leicester), Mr. H. M. Riley (Leicester), Mr. J. W. Bickley (Milton Mowbray), Mr. J. H. Smith (High Croft, Leicester), Mr. T. Walker (Rothley), Mr. W. S. Pridmore (Hinckley), Mr. L. Esbrook (Ashby-de-la-Zouch), Mr. H. J. Goshall (Milton Mowbray), Mr. H. Bond (of Walcot), Mr. Johnson Ward (Quorn), Mr. W. Lowe (Rothley Plain). The following officers were then re-elected: Treasurer, Mr. W. L. Emmerson, Waltham; auditor, Rev. A. M. Rendell, Coston; secretary, Mr. Edwin Ball, Waltham. The question of obtaining the services of an expert was considered, and it was resolved that a circular should be sent to the members inquiring their wishes on the matter, after the subject had been considered by the committee. The thanks of the meeting were tendered to the secretary for his services, Mr. Spencer, of the Market-place, for a gratuitous advertisement, the Mayor of Leicester for the use of the Parlour, the treasurer, and the chairman, after which the members separated.

#### HEREFORDSHIRE BEE-KEEPERS' ASSOCIATION.

The annual meeting was held on Jan. 11th at Howlett's Hotel, Hereford, Dr. Bull in the chair. The report (the substance of which was given in the *B. B. J.* for Oct. 1st) was read, also the report of the expert (Mr. J. R. Hole), stating that, in his autumn tour, he had visited 34 members and overhauled 150 hives. The accounts showed a balance in hand of 117. 7s. 8d.; and

considerable satisfaction was expressed at the fact that the Association, which commenced the year with 12s. 4d. in hand and no property, was now free of debt, the possessor of two bee tents and fittings (value over 45s.), and still with a good balance in hand. The office of President being vacant by the death of Earl Somers, James Rankin, Esq., M.P., was elected to the post. Mr. Alfred Watkins was elected hon. sec. The Rev. J. E. Sale, who first started the Association, and had filled that office, being about to leave the neighbourhood, the Rev. F. S. Stocke-Vaughan was elected Treasurer. A bar-frame hive was then drawn for by the members, in accordance with the rules.

The Rev. J. E. Sale moved the following resolution, which was carried: 'That the medals and certificates given by the British Bee-keepers' Association shall only be awarded to those who have been members of the society for six months previous to the date of the annual show; that they shall not be awarded to the same members oftener than once in three years; and that any member having received the same medals from another Association shall be disqualified from taking them here.' The Committee decided to subscribe for and place the *British Bee Journal* on the tables at the public reading-rooms at Hereford, Ross, and Ledbury.

#### MALVERN BEE-KEEPERS' SOCIETY.

##### IN CONNECTION WITH THE WORCESTERSHIRE BEE-KEEPERS' ASSOCIATION.

This society was formed last year, and held its first annual meeting on the 31st January, in order to receive the Secretary's report. The receipts were 47. 9s. 6d., and the expense 37. 11s. 10d., leaving a balance in hand of 17s. 8d. The principal work done during the year was the visiting (by some of the members) of the cottagers and labourers who keep hives, in order that they might learn to keep their bees on the humane principle, and to show them how to take their honey, and also to introduce the bar-frame hives. As this society was formed to train the poorer classes it has been very successful, and several of them have also now joined the county society, and the committee strongly recommends that similar auxiliary societies should be formed in places distant from the county societies. After the election of officers for the present year a vote of thanks was given to the honorary secretary, Mr. W. Paddison, for his services, and he was unanimously re-elected.

#### GLOUCESTERSHIRE BEE-KEEPERS' ASSOCIATION.

I am sorry to find that Mr. Bartlett could not meet with sufficient encouragement to commence a Bee-keepers' Association for the county of Gloucester. I have no doubt, that if he had courage enough to start it, it would succeed all right, as I think that I could procure ten or twelve members in this neighbourhood, and I have no doubt, but there might be quite as many got to join at Cirencester, and that would be more than the Devon Association had at their commencement, as, according to their Report in the February Number last year, they had only twenty members at starting; but had increased to 200.

Of course, many other towns would be able to do as much as the two named, so that I hope Mr. Bartlett and Mr. Slade will see it right to have a number of prospectuses printed, and send to parties in the different towns who would take the trouble to distribute them amongst the bee-keepers in their respective neighbourhoods. I shall be quite willing to take Lechlade, Fairford, and Cirencester.—JOSPH COOK, *Fairford*.

## NORFOLK AND NORWICH BEEKEEPERS' ASSOCIATION.

### ELECTION OF COMMITTEE.

Some one—not the present Hon. Secretary of this Association—has sent you a misleading and, in some ways, an offensive report of the general meeting. Of the 13 members present there were only 4, out of some 80 members living in Norwich, or close to it. Mr. Booker-Hill, who was the first to propose a Norfolk Association, and myself, who have both worked hard for the spread of bee-keeping in the county, are ostentatiously named in a way which shows a very bad animus in the writer. J. LAWSON SISSON, *Edinburgh*, February 11th, 1884.

## Foreign.

### HOLLAND.

An International Exhibition of Apiculture is to be held at Amsterdam between the 25th of August and the 6th of September next, in which it is anticipated that Apiculture will be largely represented. The following prizes have already been fixed, viz.:—

	1st.	2nd.
No. 322 for bees of different races . . .	50 fcs.	25 fcs.
.. 323 .. beehives . . . . .	50 ..	25 ..
.. 324 .. outdoor appliances . . . . .	50 ..	25 ..
.. 325 .. indoor . . . . .	50 ..	25 ..
.. 326 .. honey (not less than 5 kilos) . . . . .	50 ..	25 ..
.. 327 .. wax ( . . . . .)	50 ..	25 ..

Besides the money, the winners will be presented with a commemorative bronze medal each. All applications for space or information should be addressed to the 'Secrétaire du Comité exécutif de l'Exposition,' at Leerdam, près La Haye, Holland, not later than the 1st of April next. All goods must be delivered, carriage paid, not later than the 23rd of August.

### FRANCE.

The *Apiculteur*, the oldest bee journal in the country, has just entered the twenty-eighth year of its existence.

Owing, probably, to the frequency with which depredations have been committed of recent years in some of the Departments, the practice of setting up man-traps and spring guns round the apiaries has become somewhat general in certain districts. Quite recently, according to *L'Apiculteur*, a landowner of Bienville (Meuse) had recourse to these expedients in order to protect his hives. A man named Raymond, approaching it for some purpose not yet explained, did not see the board notice, and touching the wire connected with the gun, was shot dead. The unfortunate man was the father of ten children.

The analyst of the Municipality of Paris reports having examined, in the course of December last, among other articles, four samples of honey, one of which was found adulterated by the addition of glucose. In connexion with this report it is also mentioned that Paris dealers in colours complain loudly of the quantity of wax now offered for sale in the market.

In the course of last year death has removed two prominent bee-keepers, one being Mr. Antoine Siau, of the Pyrénées-Orientales, and the other Monsieur Doucin, a noted bee observer of Les Rochers.

French bee literature has just received a valuable addition by the appearance of the first number of *Le Rucher*. It is published under the auspices of La Société d'Apiculture de la Région du Nord, and will consequently be the nearest French bee journal to the English coast. It is edited by the well-known apiculturist, M. A. Leroy, whose address is No. 22 Rue Blin-de-Bourbon, Amiens, Somme.

The central French Society of Apiculture and Insectology held a meeting in Paris on the 16th of Jan. last, in order to elect the new committee of management. The following gentlemen will, therefore, constitute the board for the present year, viz., Dr. Marmontant, chairman; M. Vignole, assessor; MM. Maurice Girard and Mallesard, vice-presidents; M. Hamet, general secretary; MM. Delinotte and A. Fournier, secrétaires des séances, M. Sigant, treasurer; and M. Pillain, archiviste. So far all the reports reaching the Association show that bees are wintering well in every part of the country, really cold weather having only prevailed one week.

The honey market has been very quiet throughout last month, and consumption is rather smaller than during the latter part of the old year. It is supposed that this dullness is due to the mildness of the weather. White lots have been quoted from 115 to 170 francs per 100 kilos, according to quality. Chiff from 100 to 125 francs in Paris, and from 85 to 115 at Havre. The price of wax remains steady at previous quotations, viz., 305 to 315 francs per 100 kilos in bulk, in bond.

### SWITZERLAND.

A NEW METHOD OF CURING FOUL BROOD.—So far I had managed to stir clear of foul brood, but at last I brought it into my apiary by the purchase of a stock near Versoix. I was unable to bring away with me the one I had selected in particular, and the man sent me the wrong one. I may mention, by way of explanation, that this hive was not one of the movable-frame principle, and it afforded, consequently, no facilities for examination. However, the stock declined very rapidly, and in the end it was robbed by the others. But when I at last discovered the disease, three out of the eleven stocks of which my apiary consisted had already perished. I then took away from all the others which showed signs of infection, two or three of the worst combs, and then poured repeatedly into the corners of the hives where there were no bees a few drops of pure essence of *Eucalyptus Globulus*, which I receive direct from Grasse, Alpes Maritimes, France. I may say, in passing, that previous to my making this experiment I had made great use of this essence for curing inflammation of the gums and for other operations of a surgical nature. Old combs were all carefully cleansed and dipped into water mixed or perfumed with this essence before being again used. The result was that all my hives revived, and in the course of this year no signs of foul brood have manifested themselves in my apiary.

Acting upon the principle that prevention is better than cure, last autumn I perfumed with the same essence all the syrup I supplied to my bees, and it is to this precaution that I attribute the increased energy and vitality which have distinguished my bees until the end of the season. The perfume thus imparted to the syrup is a most agreeable one. As you probably know, this essence is anti-febrile, anti-scorbutic and anti-inflammatory; it possesses, moreover, the advantage of being neither acid nor poisonous like all the salicylic acids.

I am so pleased with this discovery as an efficient and simple remedy for foul brood that I should like to see it carefully tested by those who have more time than I at their disposal.

The *Eucalyptus* is used in many surgical operations in place of salicylic acids. I have myself used it for the last six years as a disinfectant for the mouth, in fact it was just in using it in this way that I was led to try it as a remedy against foul brood.—H. BAUVEN, (*Translated from the Bulletin d'Apiculture pour la Suisse Romande.*)

### AUSTRIA.

From the *Bienenwatter aus Boehmen* we learn that at the census taken in 1880 in the Empire of Austria (exclusive of Hungary) it was found that 926,312 colonies of bees were kept, which produced 5425 tons of



honey and wax: representing a value of 2,134,272 florins, or about 213,427*l*. There are eighteen large Apicultural Societies, with a membership of 7100, and eleven bee-papers are published. The exports exceed the imports by 384 tons weight of honey and 72 tons of wax.

#### GERMANY.

On the 16th Jan. last Dr. Dzierzon entered upon his 74th year. In 1855 the German and Austrian bee-keepers intend to commemorate the great master's jubilee (fifty years) as a bee-keeper, and for this purpose it is proposed to hold the thirtieth meeting of the German and Austrian bee-keepers in Silesia, Dr. Dzierzon's native province. Every effort will be made, on this occasion, to do honour to this great and well-deserving bee-master on the evening of his life. Mr. W. Vogel, the permanent vice-president of the German-Austro-Beekeepers' Union, and editor of the *Bienenzeitung*, is already occupied in forming a committee to make the necessary preparations for the said commemoration.

#### CUBA: ITS PRODUCE OF HONEY AND WAX.

Amount of honey exported from Havana during 1850-1851, 2,517,360 lbs.; exported from Nuevitas during 1851-1852, 5,100,000 lbs. Amount of bees-wax exported from Havana during 1850 and 1851, 143,775 lbs. Of the above Germany received two-thirds of the honey at the average price of 4*l* cents per lb.; United States, Belgium, Great Britain, and Spain, the greater proportion of the balance at the same price. Of the bees-wax Spain received nine-tenths at an average price of 30 cents per lb., England and France taking most of the balance. The amount of bees-wax exported from Nuevitas has not been ascertained. Nuevitas is the seaport of a country about 100 miles square, having Puerto Principe for its centre, the latter being about 500 miles east, and fifty miles south of Havana. It will be seen that, if instead of bees-wax, honey had been produced, we should have to add to the above over 10,000,000 lbs., making a grand total in two years of 17,617,360 lbs. of honey, not including any bees-wax from Nuevitas, which probably produce a proportionate amount. Now, when we consider that only two parts furnished this amount, and there are three others of about equal importance in the export of honey and wax, we begin to get some idea of this *El Dorado* of the apiarist. Yet before the war had desolated the island, it appears that fully twice the above amount was exported annually. A letter from Mr. Osburn, Cuba, states, "I have been in the bee business for fifteen years, most of the time in Southern California, and thought no other country in the world equal to its black sage honey flows in the immense yield, as well as the quality produced, but now I am compelled to confess that Cuba exceeds all." *The American Bee-keepers' Magazine*.

LECTURE ON BEE-KEEPING.—A lecture on bees and modern bee-keeping, with illustrations, was delivered on the 5th inst. by the Rev. John Kerr, M.A., Dirlton, East Lothian, in Newtowngrange school-room, situated on the Marquis of Lothian's estate, near Dalkeith. The lecturer sketched the history of bee-culture from the earliest times down to the day of modern bee-cultivating societies. Proceeding, he gave a minute description of the bee's different organs, illustrated by diagrams. In the second portion of the lecture Mr. Kerr gave a practical explanation of successful bee-keeping, which was much appreciated by the audience, illustrated, as it was, with a large assortment of hives, feeders, and other apparatus, supplied by two of our local bee-keepers. In closing Mr. Kerr expressed his willingness to assist in the formation of a local society for the promotion of bee-culture. It is hoped that our local bee-keepers will avail themselves of Mr. Kerr's kindly offer.

## Correspondence.

*All Correspondents forwarding Letters for insertion in the Journal, Reports of Associations, Shows, Meetings, &c., should send them to the Editor, 11, Mark Lane, London, E.C.3. The Editor of the "British Bee Journal," c/o Messrs. S. & S. 11, Mark Lane, London, E.C.3.*

#### OUR HONEY IMPORTS.

The value of honey imported into the United Kingdom during the month of December, 1883, amounted to 1230*l*. (From a private return sent by the Principal of the Statistical Office, H. M. Customs, to E. H. Bellairs, Wingfield, Christchurch.)

#### BEEHIVE COMPETITION.

Allow me to suggest, for consideration, another alteration in the rules for the proposed Economic Apiaries Competition; and that is the one which taxes 2*l*. on the limit of expenditure. This sum does not seem to me a convenient one, as it is open to the objection that has been made to a 2*l*. case as a bid for the table. "Too much for one, and not enough for two." Competitors are naturally tempted to start two stocks, if possible, and then, unless the same are very small, or put in the worst make-shift hives without much foundation, the owners are crippled for want of funds, and so may have to resign the competition altogether in order to avoid loss. I suspect that could I see the missing diaries of those who withdrew from the last year's I should find that this was the case in more than one instance. Mr. Kirk Allen's success with a half-pint of bees is very creditable to his management, but it is hardly the way to teach scientific bee-keeping. I would suggest that either 30*l*. or 50*l*. should be the limit; the former sum would perhaps be best as that would limit each entry to one stock of thought desirable the entrance-fee might be proportionally reduced. I do hope, however, that the competitors may not again be limited to one entry. It is very desirable that the different systems, or methods, of honey gathering should be compared together, and if in the same locality and under the same management so much the better. Bar-frame hives—for extracting and supering—Bettignow skeps, and Stewartons, all want testing, and if possible, side by side. I may say here that though in theory I very much object to skeps, in practice I found last year that a large skep gave me a greater profit than any other hive in my apiary, and one of a similar kind belonging to my servant, also, proved more profitable than any of his frame-hives. Referring to Rule II., could not members of Bee-keepers' Associations, who have the misfortune to reside in counties which do not yet possess an Association of their own, be admitted to compete, provided they could induce the Hon. Sec., or expert of some neighbouring county, to visit them in accordance with Rule IX.?  
Geo. SIMMONS, *Cheshamfield*.

#### MRS. SIMMONS' HIVE.

There is much that is useful in Mr. Simmons' very practical article, and I am glad to see he advocates simplicity in hive-making. His protest against the long top bar of the Standard frame is most timely. I have always been of the opinion that the Frame Committee made a great mistake in adopting 17 inches as the length of top bar, for to my mind the practical business hive of the future will be made with stout single sides, and the present standard will not fit it, whereas a 15½-top bar will fit any hive; the sooner the British Association alter their standard in this respect the better. I also cordially endorse Mr. Simmons' opinion as to the useless-

ness of distance-pins and broad shoulders. The roof he describes is a capital one: I have used it for five years, and found it bear the test of time; it was, I think, originally introduced by Mr. Fuggle, of Sussex. I think Mr. Simmins is right in his disapproval of plinths round the roof and floor-board joints of a hive; they are apt to give trouble when the wood swells, and are quite unnecessary if the hive is accurately made.

There is one point in which I think Mr. Simmins' hive is decidedly behind the times. No wonder he requires 'draught-preventers' when his frames run towards the entrance, thus allowing the draught to find its way up each seam. When the combs are placed *across* the entrance, the first comb acts as an efficient draught-preventer. I can speak from practical experience on this point, having used hives on the two systems for several years, and have invariably found that where the combs run across the entrance more brood is raised, and that often towards the edges of the comb, which has never been the case when the frames run towards the entrance. The idea of placing three crates of sections on the top of the hive, instead of having one crate covering the whole of the top, is worthy of a thorough trial.—ALFRED WATKINS, *Hereford*.

#### SIMMINS' HIVE.

The thanks of your readers are due to Mr. Simmins for the lucid directions with which he has favoured them for making a hive; and, if you will allow me to offer a few remarks upon them, I trust he will not consider them in any way personal to him, but as made for the purpose of calling the attention of beginners, who may be attracted by them, to certain alterations which might be advantageously adopted.

I quite agree with Mr. Simmins, that if we are to break up old cases and use the materials as wood, it is far better and nearly as cheap to use new wood; but the ease with which almost any box, if sound and large enough, may be converted into an excellent double-walled hive suited to the best methods of working is so great, that I am sorry Mr. Simmins condemns all makeshift hives. The plan I allude to was suggested by Mr. Abbott some time ago, and is simply to fix two 9-inch boards (8½ when planed) from end to end of the box which I take for granted is at least 10 inches deep, at a distance of 14½ inches apart. The space thus formed between the boards constitutes the hive, those between them and the side of the box may be filled in winter with chaff. An entrance made at one end, the lid covered with floor-cloth, or painted canvas, so as to be waterproof and an excellent hive, only wanting the frames and division-boards, is formed at a very small cost. My object is not, however, so much to defend makeshift hives, as to criticise Mr. Simmins' new one.

My first objection is, to his remark, that the 17-inch top bar of the Association Standard frame 'looks, and is, awkward.' I do not think I am singular in having a dislike to taking hold of the frames by the middle with the danger of crushing a bee, and the nuisance of getting one's fingers smeared with sticky propolis. This is inevitable with Mr. Simmins' short-ended frame; but the Association bars can be lifted by the ends and a heavy frame can be held in one hand with ease, the long ends affording a grasp.

Secondly, I say that those who use guides can use nothing *worse* than wire staples and nails. When wide-shouldered frames are properly constructed with the shoulders flush with the inside of the wall of the hive, far less propolization will take place than when distance-pins are used. The bees cannot get between the frame ends to fix them. I must admit, however, that some of the frames with which hives exhibited at shows are filled, seem as if they were designed for the special purpose of being stuck together. Again when wide shoulders are not used, in order to confine the heat the

quilt must overlap the frame-ends, and rest on the hive side or fillet, thus coming perilously near the driving moisture, and liable to absorb it by capillary attraction. I wonder how Mr. Simmins manages in his breezy situation with one pair of hands to keep his quilts from being blown off while he picks up and puts on his roofs.

The means of preserving the quarter-inch space at ends of the frames is also open to objection, as the frames being made to fit the rabbets in his hives are not interchangeable with other frames from hives, even of the same construction, in which the rabbets happen to be a little broader. Now, if under shoulders are used, the frames will fit any hive of the same internal measure. If I understand Mr. Simmins aright, he makes his dummys for a 14½ inch hive only 14 inches wide, leaving half inch to admit cold air in winter, and to be filled up with propolis or comb in summer, when it will not long remain 'easily moved.' The method of making the frames also involves a great deal of unnecessary labour, and unless the under side which is cut away is perfectly true and parallel with the upper side, the frame will not hang plumb. What objection is there to the heads of the nails showing at the top of the bar that so much trouble should be taken to prevent it?

To turn to the hive; I submit that according to the present generally accepted principles the frames run the wrong way; and if the Standard frame be, as I consider it should, adopted in its integrity, double-walls to admit the 17-inch top bar become a necessity as they are also for successful wintering of bees. Other objections are included in those to the frames.

The roof, which Mr. Simmins recommends, is bad in many ways. The four joints are most difficult for any one but an expert joiner to make true and water-tight, and are almost certain to open with the weather, and admit wet to the quilts. Mr. Barkitt's suggestion of Williseden cardboard is a good one. I have one hive roofed with it to try, and it seems to be unaffected by the weather. In the course of some building operations, a scaffold pole was dropped on to it. It is a good deal out of shape, but not broken. A wooden roof would have been split and admitted wet. It is of 4-ply, the 2-ply is hardly strong enough except as a cover to boards; while on the subject I can tell Mr. Barkitt that bees will bite 2-ply. Last autumn, robbers bit their way to a bottle covered with 2-ply.

To return to Mr. Simmins' hive; by cutting a board as he suggests and using two of the boards so obtained one at each end of the hive, attached to each other at the two top corners and at the two bottom corners by laths, and covered with 4-ply Williseden cardboard, a roof can be made in one-tenth the time occupied in chamfering the four boards, which will be perfectly waterproof and likely to remain so. As to the question of making sections or buying American ones I will not follow him; let those who like to do so make their own, and if they cost less than the American, they must put very small value upon their labour. Mr. Simmins' crates are neat and good. I have only skimmed Mr. Simmins' lengthy paper for the purpose of friendly criticism. Had I noticed it in detail, this letter would have run to almost the length of his paper.—F. LYON.

#### SIMMINS' HIVE.

I fully expected that some of your able correspondents would have drawn attention to the numerous defects in Mr. Simmins' Economic Hive, of which he gives 6-tail in your issue of Jan. 15th. As no able hand has thought it worth his attention allow me to do so.

In the first place, I consider he has killed the hive with economy, as at best it is only a makeshift, as I hold no hive is suitable for wintering that is not at least ½ in. higher than the frames, to allow for the proper

packing of the quilt at the end, the most dangerous part for draughts; nor that does not come down over the floor-board on at least three sides. It can be done without plinths, as I shall hereafter show.

As to his draught-preventer, all I have to say in favour of it is that I do not believe in making my bees take a far-about road for more handliness; and with a small door, a good quilt, and close-fitting dummies, with knife edges, I have never found it necessary. But should any ordinary amateur attempt to make his hives, unless he is an adept at the square and rule, I should not wonder though he should need a few of them.

His bars I consider cumbersome and difficult to make. He objects to the long top bar. Well, I like a long top bar, so that I can get a good hold of it, and can turn it any way while holden by the ends without fear of letting it slip.

Next the roof. He says it throws off the water better than any other he has been able to make. Well, admitting that, which does not say much for him, it is only a cover, and that is all he claims for it. The space within is almost useless for supers. I have only one of that shape, and mine is half checked at the corners, and I have had more trouble to get it water-tight than all my others.

Again he says, 'My crates are not simply racks; but he might safely have added, 'shamply bee-crushers.' I am perfectly astonished to hear of one using such an article, more especially one that terms himself a professional bee-keeper. I am not afraid to assert that not one in twenty could take this sparrow-box he describes off, and put it on a full hive without crushing a great many bees. Now, taking into consideration the super he uses, I fail to see the use of the box at all, as their ends keep them the proper distance from the frames; and to be economic they could be built on the top of the hive like bricks, with simply a board at back and front to close up the open sides. At least, in using a super the same as his, but larger, that was the way I did, but mine was well covered up, and he seems to infer that his does not need covering.

There are a few of his trifling minor details that in order to meet more fully, I would rather, with your permission, describe a hive that is efficient, economic, and simple in construction, that will keep out the summer sun and the winter's cold without a draught-preventer. In doing so, I will get over a few of his difficulties in an easy manner.

For ends of body-box two pieces 1-in. board  $16\frac{1}{2} \times 11$ . I cut a cheek along one side of these  $1 - \frac{1}{2}$  in., for the back one piece  $22\frac{1}{2} \times 11 \times 1\frac{1}{2}$  in., for the front one piece  $22\frac{1}{2} \times 10 \times \frac{1}{2}$  in. Nail the back and front to the ends, keeping the front in line with the top of cheek, so as it will rest level on the floor-board. The floor-board is made thus:—One piece 1 ft. long by  $6 \times 1$ , measure 19 in. from opposite sides, and cut angle. To cover this

$14\frac{1}{2} \times 8\frac{1}{2}$ , run to a knife edge on three sides. Nail a piece  $\frac{1}{2}$  in. square,  $16\frac{1}{2}$  long on top; drive in two pieces of wire into bottom of each to project  $\frac{1}{2}$  in., and file to a sharp point to catch in the bottom board. The bars, of which the hive holds fourteen—but it can be wrought with any number less—are made thus:—Top of bars,  $16\frac{1}{2}$  long by  $1 \times \frac{1}{2}$  in.; ends,  $8\frac{1}{2} \times 1 \times \frac{1}{2}$  in.; bottom,  $14 \times \frac{1}{2} \times \frac{1}{2}$  in. For making the bars, I use a block made thus:—One piece 2 in. thick,  $16\frac{1}{2}$  long by  $8\frac{1}{2}$  in.,  $1\frac{1}{2}$  in. from the ends. I make a groove  $\frac{1}{2}$  in. wide by 1 in. deep. This holds the ends. They are kept in position by two short pieces fastened with a screw that turns on upon them on the top. A piece  $1 \times \frac{1}{2}$  in. is nailed on to keep the top bar in place till nailed; then turn up and put on the bottom rail. The ends of top bar are pointed thus  for convenience in handling. I use no distance-pins, as in winter I set them wide, and in spring closer than usual.

The super-box, which I hold no hive is complete without, to allow of the proper packing of the quilt in winter, is made thus:—Ends,  $16\frac{1}{2} \times 6 \times 1$  in.; front and back,  $22\frac{1}{2} \times 6 \times \frac{1}{2}$  in., nailed together; 1 rip these out of 3-in. wood. The two pieces of the  $\frac{1}{2}$ -in. ripped again goes to form a plinth around the bottom of super-box. This will keep out damp, and any number of them can be piled above one another. From one of the 1-in. pieces I make a guide for the doors thus:—Cut an  $\frac{1}{2}$  in. square cheek along one side; then shape it as shown, bevelling it to throw off the rain; then off the other piece I rip  $\frac{1}{4}$  in. for the doors, and cut it in two, setting them with a shaving underneath them. To make them easy to work, I put on the guide, and fasten it with screws.

For the top take two pieces 2 ft. long  $9 \times \frac{1}{2}$  in.; rip off  $\frac{1}{4}$  in.; then shape them as shown.

This forms the ends; then take three pieces  $24 \times 11 \times \frac{1}{2}$  in.; draw a line  $3\frac{1}{2}$  in. from the end as a mark where to place the ends; then

nail on two of them on the bevelled sides of the end; plane down to level at top; put this on top, and draw a line inside where to drive on stopper. One of the pieces you ripped off ripped again will do for stoppers. Bore a 1-in. hole in each end for ventilation, and put on top board, when you will have a complete and substantial hive, and if kept well painted it will last a lifetime.

I cut all my wood on a block, where the saw works in a groove, so that I get my end perfectly square without planing, and all my ripping is done with a small foot-power circular saw. Parties making a few hives at a time can get all the wood cut to the size at the sawmill at very little more cost.—JAMES SADDLER, *Esq.*

#### EXPERIENCE WITH A STEWARTON HIVE.

Finding one of my Stewarton hives very busy this morning, when the other hives were comparatively quiet, I deemed it well to examine it, and see if the bees required food, or other attention. I was glad to observe that the combs contained an ample supply of sealed stores, and upon taking out the two central frames, was pleased and almost surprised to find them quite full of brood in all stages; many newly-hatched bees were running over the combs, and the queen appeared to be in good laying condition. This hive, and some of the others, contained so much sealed pollen in the autumn, that I rather feared that it might prove detrimental to the future welfare of the colony; but it has been most useful, by enabling the bees to raise a large quantity of brood, at a season when they have been unable to obtain any supplies from outside, and the

194

284

284

194

take two pieces  $\frac{1}{2}$ -in.  $21\frac{1}{2} \times 11$ , and one piece the same length but 9 in. broad. Nail one of the 11-in. pieces on the face of the angles, keeping one at each outer edge, and plane down to the level; then place the 11 and 9-in. pieces on top, and plane off to the angle of front. Set the body-box on this; then for inside take two pieces  $20\frac{1}{2} \times 11 \times \frac{1}{2}$  in.; rip off 9 in.; plane it down to 9 in.; run the top to a knife edge, bevelling from both sides; then out of the two pieces you ripped off rip four pieces  $\frac{1}{2}$  in. Nail these on the back of the outside boards  $\frac{1}{2}$  in. from top and bottom; place these inside, and fasten with four screws each; then cut out your door at front 12 in. long by  $\frac{1}{2}$  in. Dummies, two pieces  $\frac{1}{2}$  in. thick,

combs will now be in excellent condition for the reception of eggs in the ensuing spring. None of my hives have been fed, or in any way interfered with, since October.—J. E. BRISCOE, *Abrighton, Wolverhampton, Jan. 30.*

### SHALL WE PRODUCE COMB OR EXTRACTED HONEY?

On page 48, last issue, Mr. W. B. Carter endeavours to show the cost of producing a pound of comb-honey. Mr. Carter deserves great credit for his careful and painstaking proceeding in endeavouring to get at the exact weights respectively of honey and comb (or wax) contained in the one-pound section. He will, however, I feel sure, on further consideration, admit that his figures require some modification.

In the first place, the value of the honey contained in a section does not represent the cost of production, and therefore to get at the actual cost to the producer when compared with extracted honey, I submit that only the cost of foundation, the section, and additional weight of wax added to the original weight of the starter, should be set against the price to be obtained for the whole. As regards the cost of labour, &c., I can see little difference, whether extracted or comb-honey be produced, so that item need form no part of the bill of expense.

Now if a full sheet of foundation be placed in a section (for which Mr. C. does not forget to charge the account), the weight of that should of course be deducted from the weight of comb after removing the honey.

Again, if we are making a comparison with extracted honey, for which the wholesale price is seldom more than 7d. instead of placing it at 1s. per lb., the former sum should be taken as a guide; and after deducting, say quite half the weight of comb to represent foundation supplied, the statement of cost would read something like this: six ounces honey, used in producing extra wax, at 7d. per lb. = 2½d. Section and foundation, ¾d.; total expense (exclusive of labour), 3½d. The wholesale price of comb-honey averages 1s. 3d. per lb.; the balance of profit to the producer is therefore 11½d.

It has often been stated that one can obtain nearly twice as much extracted honey as comb. That may be the case where bee-keepers extract the honey before it is well ripened; but when we wait for a good article, and have it nearly all sealed, it will be safe to say that one-half more can be obtained.

Against our 1-lb. section at 11½d., we must therefore place 1½-lb. extracted honey at 7d. = 10½d., which still leaves 1d. in favour of comb-honey. This is supposing it takes 20 lbs. of honey to produce 1 lb. of wax. This statement I have always considered an error, but hope soon to put the matter to a practical test. Even if 20 lbs. of honey were consumed while producing it, a deduction would have to be made in respect of the amount taken by the bees for their own support during the time the experiment is carried on.

Beside the slight balance shown in its favour, we can therefore give the comb-honey the benefit of that doubt. We know, also, that it is a much cleaner article to produce, and that it commands a ready sale at all times.

How important is it, too, that we endeavour to supply our sections with foundation having a thin base, but with walls to the cells containing sufficient material to nearly, if not quite complete, their full length; considering that the one-half of the whole weight of comb is supplied by us at one-sixth the cost of that added to it by the bees.

As regards selling extracted honey at 1s. a lb., I must say that those who can get it can do no better than work for that article, and it will pay them well. But can that price be obtained at all times? Most certainly it can not; and when we hear a man saying that he can get that amount for extracted honey, we know at once that either he has a small retail trade at home, or else he

is producing it in very limited quantities. What bee-keepers in general have to consider is the wholesale price of their products where they have a large quantity to dispose of; and that being so, others will find, as I have done, that whether they sell in bulk or go to the expense of bottles and labels, their net returns will be no more than 7d. per lb. for the extracted article.—SAMUEL SIMMONS, *Rottingham.*

### WOODLEIGH'S TWIN-HIVE PORCHES.

Adverting to the 'Woodleigh Twin-Hive,' illustrated on page 31, January 15th, I beg to say that I consider it a mistake to have such porches to entrances as illustrated. I think that whenever the wind may blow towards the entrance, it must accumulate in the porch and enter the hive with greater force than if no porch existed. I have used a draught-preventer, something like that recommended by Mr. Simmons (page 25), which appears more to the purpose.—J. R. W. H.

### LOWER GRADE OF EXPERTS.

I beg leave to reply to the Rev. Geo. Raynor's criticism of my stumbling attempt in your issue for Jan. 15. In common with people who write or speak in public, I have to mourn being misunderstood, possibly from want of clearness or better descriptive powers. Whichever it may be, I must beg of the rev. gentleman to correctly quote what I said: my words were 'convenient time and place' (not 'numerous places'). To be more definite, I would say, whenever the County Show for the time being is held would be a suitable place, and there would ordinarily be no lack of examiners in the craft who would devote an hour or two to putting 'Hodge' through his facings, and that at a trifling cost to all parties concerned, seeing candidates and examiners would be brought together at the show. I may say I read the syllabus of subjects referred to on p. 62, Vol. XI.; likewise I read editor's notes on show and examination of experts, p. 33, same volume, which I would like to refer him to. There he will see that the last straw that broke the camel's back in the case of some of the candidates was the lecture. The fact of my not referring to the examination papers does not prove that I know nothing of their existence; I simply spoke of what appeared the most difficult task. No doubt the rev. gentleman's ideas of the difficulty of public speaking and mine are different, seeing in his professional career he has addressed many concourses of people.

I must apologise for not quite defining the person I meant under the appellation of 'Hodge.' I did not quite mean the ordinary agricultural labourer or teamster, but one very slightly removed from him—a groom or gardener, especially the latter. Who has not been in the habit of associating from their earliest days bees, flowers, and garden produce together? Often a young gardener has to leave his native place and parental roof, where he has had inculcated into him the rudiments of bee-keeping, to go to a situation perhaps fifty miles away. His new employer knows nothing of his apicultural skill. To such a one I believe the much-despised parchment would be useful; and I cannot see as it would in any way interfere with the regular expert. Your esteemed correspondent seems to think it would be a backward movement; I do not, however. It would help to popularise bee-keeping much. Our friend, the veritable Hodge, would not mind stepping across the way to Spire So-and-so's gardener to ask what he should do with his bees when in some minor difficulty. Perhaps it may be said he could apply to a regular expert. To (his I reply, it will be some time (if ever) before experts become numerous enough to be within anything like reasonable distance. And then there is the natural diffidence which we feel in approaching our superiors. And

this "Hodge" blunders along, charged by some, happily not by all, with being dull, ignorant, and a multitude of other similar names; whereas if persons that he could understand were accessible,—what he is capable of the *Journal* has lately given proof,—provided he is sober and temperate, and keeps clear of the paid agitators referred to some time since by, I believe, the Rev. Mr. Sisson in a lecture which he gave,—I argue that hard work and experience will accomplish its end. It is a question with

me which of the two will benefit the intelligent cottager the more,—one of his own class who has made his way and won his spurs by sheer perseverance, or a gentleman who has subjected himself to the cramming process, and thus acquired in a few months what it took the other years to learn.

I hoping I have not uncourteously treated one of the Fathers of Modern Bee-keeping, Hermann, &c., PLATE-LAYER, *Zuchliger*, 1875, &c.



## THE HEATH APARISTS.

### II. THE BEES.

It is a well-known fact in Germany, that the Heath apirists have a special kind of bee, which is different in many respects from the common German bee, and is familiarly known to German bee-keepers by the name of "Heath-bee" (*Heidbienen*). Von Berlepsch, Dath, and other eminent bee-masters, consider it an improved bee.

Of course the heath-bee is a descendant from the common German bee, but it has been reared for many centuries in the same way as the English cattle-breeders rear their famous stock, that is, by selection for special purposes. This circumstance will prove that the Heath apirists have attained a lofty eminence in bee-keeping, inasmuch as they have been successful in rearing a bee which is so suitable in every way to their requirements. The Heath-bee is, in its outward appearance, very similar to the common German bee; but is distinguished from the latter by being a swarm bee, that is, a bee which is prone to swarm, and casts off three or more swarms. The common German bee will give some years one or two swarms or none at all, but will never swarm if its combs do not reach nearly the bottom board of its hive. A first or second swarm will seldom give another swarm in the same year, and a young queen never leads off a swarm in the year of her birth. A colony with such a queen will never build drone-comb in that

year. It is, therefore, with the Heath-bee, it will swarm immediately, even if the combs fill only half the hive. First and second swarms will cast other swarms. A young queen will lead off a swarm in the year of her birth, and her colony will build drone-comb soon after hiving. The Heath-bee will go on brooding to the end of September.

It may be asked, how is it possible to make bee-keeping profitable with such a bee? The Heath apirists are able to do so. Their hives and management and their pasturage make bee-keeping a success. The swarming fever they control at the right time, and the drone-comb they cut out in the beginning.

There is no doubt that the Heath-bee is a most active bee. Its broods from early in the spring to the fall, and brood-rearing is the *modus vivendi* of all activity in a colony of bees.

Our next will give information respecting the hives in use by the Heath apirists. C. J. H. GRAVENHORST, *Brunswick, Germany*.

\* The above spirited engraving has been reduced by zinc-gravure from a sketch by G. Arnold, which appeared in *Das Buch für Alle*. (Hermann Schonlein, Stuttgart, 1877.)

### 'EXCELSIOR' HIVES, OR EVERY COTTAGER: AN AMATEUR HIVE-MAKER.

In giving instructions to make these hives (which are entirely on well-known principles) no doubt many will think they have seen this and that before, or this, that, and the other is not new, &c. My aim will not be to give a perfectly new hive, though many points are entirely so, but rather such directions as will enable anyone who can saw a piece of wood or drive a nail—no matter how clumsily it may be done—to be able to make a bar-frame hive, having at least thirteen frames, for less than 5s., and this after he has deducted the value of his time in making it, and which when done no honest man will be able to say that it is inferior in any respect for practical bee-culture to the most expensive hives extant, while in many respects it will be superior.

There have been many attempts at giving instructions to make cheap hives, but some of these have been given by professional hive-makers, who advise knocking boxes asunder for material; and some by amateurs with expensive tools, who have never experienced the difficulties most cottagers have to contend with, and are therefore hardly qualified to advise.

If we consider that most bee-keepers would prefer making their own hives, and that if apiculture is to be more successful, the capital necessary to carry it on must be greatly reduced; and if I can show how a double-walled, longitudinal hive, with at least thirteen frames, air-tight dummy, sliding entrance, well roofed and painted, with plenty of space above for supering or doubling, and which can vie for durability, accuracy, and facility of management, with any hive made, and all for less than 5s., my trouble in doing so will not be in vain; I shall accomplish what no one else has, and add a new zest to cottage bee-keeping.

The tools necessary are,—a 10 or 12-inch square, cost about 3s.; straight edge, 1d.; hand-saw, 3s.; small saw-pad, 1s.; 8-oz. hammer, 6d.;  $\frac{1}{16}$ -in. gimlet, 4d.; bradawl, 1d.; and smoothing plane, 3s., or a jack plane will do as well; you can manage very well with only one plane, though the set is three, viz.—trying, jack and smoothing. And as I proceed I shall give my reasons for preferring this or that particular thing; but all the directions will be given in such a way that anyone can vary them for himself, and thus be able to make hives that will take frames the same as he may have in use.

The square is the most important article, for on the accuracy of this tool all will depend, so I must first give directions how to tell if it is true. Get a piece of board, A, Fig. 1, with one edge perfectly straight,—which can

some practical man put it so, as it is a very difficult matter to do one's self. If you go to buy one, take the board with you and make sure you get a true one; don't be put off with any other on any account. Most likely the shopkeeper will be surprised he has not one; but never mind, if you can't get one, nail two straight pieces of wood at right angles, drive in first one nail, and when you have got it true (which can be easily done by means of the board) drive in another; this home-made square may be rather clumsy-looking, but if it is true it will be far better than any untrue one.

The next thing is a straight edge, this can be a straight lath or window-blind stick; cast your eye down, and if one edge is straight it will do. The next is a saw, if the teeth are dull or out of set, the price of sharpening and resetting is 4d. Don't do this yourself, but take it to a saw-shop (if possible) or a practical man, it will be well-spent money. The other tools are not so particular, except the plane should be sharp.

If you can't afford to buy these tools you may be able to borrow them, or a number might club together, one buying a saw, another a plane, and so on; other tools can be dispensed with as not absolutely necessary, unless it be a 12-inch rule; so there can be no obstacle for the very poorest setting up hive-making and perhaps earning a few shillings on a rainy day or when out of a job.

In beginning anything it is always best to start with materials that require the least adapting; thus in making a coat it is better to start with the wool, ready spun, woven, and dyed, rather than to take it from the sheep's back; therefore I shall start as far on as possible and use boxes ready-made, which have done duty as cases of goods imported from abroad, numbers of which can be had for nearly nothing, which are quite suitable for hive-making, without having to knock them in pieces.

For the first of these boxes I will take the Assam tea-boxes, being the most plentiful, which are about 22 inches long, 18 wide, and 18 deep, inside measure, and are made from very hard wood about  $\frac{1}{2}$ -inch thick, and well dove-tailed together, and may be got from most grocers at 4d. or 6d. each, who are generally very glad to get rid of them, as they are so difficult to pull in pieces, and so hard to split into fire-wood. These tea-boxes come from India, those from China are smaller, lighter, and not at all suitable; so be sure you get the right ones. Another suitable box is what Wheeler and Wilson's No. 8 Treadle Sewing Machines come in from America; they are 20 $\frac{1}{2}$  inches long, 19 wide, and 11 $\frac{1}{2}$  deep, inside measure, are made from  $\frac{3}{4}$ -inch pine, well seasoned, planed, and are just right to make twin hives, or can be shortened to make single hives; they may be got with the lids from any of their depots for 1s. 6d. each or less; in this town (where there is a great demand for packing-cases), I get them for 15s. per dozen. Ham-boxes will do, but are very heavy, or any other box, if it is, first, wide enough; second, not too short; and third, sufficiently deep.

There is another box imported into this country in very large quantities, made from  $\frac{3}{4}$ -inch white deal, ready planed and painted, just right width and sufficient depth to take Association frames; it only takes me ten minutes to convert one into a make-shift live, and are handy for nuclei, super-cases, swarm-boxes, and a host of odd things in an apiary. They cost 6d. each; but as I do not consider it a hive proper, being single-walled, and only holding seven frames, I will give further particulars of it at the end of this article as a useful thing to get, though I have wintered stocks in them.—JOHN HEWITT, Sheffield.

(To be continued.)

SADDLER'S TABLETS.—Through your columns allow me to thank Mr. J. Saddler for the receipt he gave (in the *British Bee Journal*, August 13th) for making candy and flour-cake. I have made some as directed, and it is the best I have seen. I would recommend all who have any trouble in making candy to use his receipt.—J. BULL.

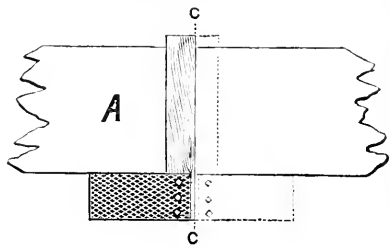

Fig. 1.

be seen by casting the eye down it—and place the square across as shown in the figure, and draw a line c c across the board along the edge of the square; now turn it over as shown in dotted plan, and if the square is true it will lie parallel to the line c c, but if not true it will form more or less of a V, one way or the other up, showing just double the error. If not true it will be as well to let

## BEE-KEEPERS AT HOME.

NO. V.—THE REV. F. T. SCOTT, at HARTLIP  
VICARAGE, SITTINGBOURNE.

We offer no apology to our readers, in the continuance of our sketches of the lives of our leading bee-masters, for introducing another gentleman of the clerical profession—one who has for many years of a long life displayed that enthusiasm which is absolutely necessary for success in apiculture. In this country, in America, and on the Continent, we find clergymen taking a foremost place in the knowledge and study of the economy and management of bees. Apiculture would appear to be in close harmony with the work to which they have devoted their lives. It causes them to love the country life in which, when placed in rural parishes, they are called to pass so large a portion of their existence; it opens up to them a world of innocent pleasures; it affords an occupation to their minds, and saves them from the possibility of *ennui*; it brings them face to face with the wondrous creations of Him Who hath made all things well; and it gives them an opportunity of benefiting their parishioners by introducing to them at once a pleasing recreation and a profitable occupation.

The subject of our present sketch is the Rev. Frederick Thomas Scott, M.A., incumbent of Hartlip Vicarage. Mr. Scott was born on the 6th of March, 1812, in the town and port of Folkestone, where the illustrious Dr. W. Harvey first saw the light of day. His father was John Scott, Esq., Inspector of H.M. Customs and captain of a Volunteer Artillery Corps, at that time stationed at Folkestone. In the year 1821 the family removed from that place to Smooth, near Ashford; in which place his youth was spent, the Grammar School at Ashford supplying his classical education. Mr. Scott was always a great lover of the country, and more addicted to the study of natural history, especially of birds, than boys of his age usually are; but it is somewhat remarkable that during his holidays, which were spent at Smooth, he saw little or nothing of bees; and this can only be accounted for by the fact that no bees, that he was aware of, were kept in the parish.

In the year 1830 he entered at Worcester College, Oxford. During his college life his attention was not directed to the study of bees, except that he understood from his tutor, the Rev. R. L. Cotton, that a cousin of his at Christ Church kept bees in his room. This was the celebrated bee-master of after days, Rev. W. C. Cotton, author of *My Bee-book*, whom he had the pleasure of meeting occasionally at the great Bee Exhibitions at the Crystal Palace. In 1835 Mr. Scott was ordained by the Bishop of Lincoln to the curacy of St. Ives, Hants, where he resided for one year, the only year of his life spent out of Kent. In 1843 he became rector of Eastbridge; and in 1844 we find him perpetual curate of Hythe, Kent, noted for its being the location for the School of Musketry.

It was not till the year 1849 that Mr. Scott took any interest in bees, his attention having been drawn to them by his then curate, the Rev. Matthew Woodward, the present vicar of Folkestone, who had been greatly interested in a swarm which he had seen taken in the garden of his lodging. Mr. Scott was at once seized with the same intense desire that his curate had expressed to know something about bees, and formed a resolution to keep them. No time was allowed to elapse before putting this resolution into effect, for the following year, 1850, found him the possessor of eight swarms of bees, one being placed in a set of Nutt's Collateral boxes, which he had procured from his friend, the Rev. Frederick Freeth; another in a flat-topped hive of Mr. Payne, the well-known author of a book on Bee-keeping.

Like most bee-keepers, Mr. Scott became from this time forth an enthusiast in the science and art of

bee-keeping; and much of his leisure time was spent in obtaining information on the subject. He read all the works he could get hold of, and visited all the apiaries in the neighbourhood, and some also at a considerable distance from home. He was especially interested by an inspection of that belonging to Mr. Golding, of Hinton; where he had the great satisfaction of seeing Huber's leaf-hive in full work, as well as the Grecian hive, which Mr. Golding had done so much to introduce and recommend to the public, and which was being worked with great success by himself as well as by a neighbouring clergyman, who kindly instructed Mr. Scott in the right way of using it. This he felt to be a great step in advance. He had, like others of his time, to begin at the bottom of the ladder in his learning; and the possession of a hive with a moveable top, and bars upon which the combs were to be built removable at pleasure, rendering an examination of the internal state of the hive at any time possible, made him more than ever before master of his bees. With the use of such hives as these (Nutt's Collateral boxes having been some time discarded) Mr. Scott met with a considerable amount of success as a bee-keeper, and had the satisfaction of astonishing and delighting his friends by the sight of some excellent supers of comb-honey in glasses and boxes.

In the year 1855 Mr. Scott was removed from the incumbency of St. Leonards, Hythe, to that of Sibberts-wold, near Dover only, Shepherds-well, to which vicarage his bees were in due time removed, and where he hoped to be able to devote more of his leisure hours to the now very absorbing hobby. It was during a lengthened residence of twenty-one years in this place that a great advance was made in his knowledge of bees and bee-keeping. Here it was that he built, and then discarded as inconvenient and objectionable, a bee-house upon a large scale. He had seen in the vicarage garden of a friend at Aldbourne, in Wiltshire, the model of a Swiss chalet placed as an ornament on the lawn; and he at once set about building one after the same pattern, to serve as an apiary in his own garden. This was figured in the *Cottage Gardener*, and after some years' service discarded for the reasons above mentioned.

Here it was that, having learned from American writers on bee-keeping of the excellent qualities of Ligurian bees, Mr. Scott was one of the first of English bee-keepers to import them into this country. This was effected through the assistance of Mr. Neighbour, of Regent Street, who introduced Mr. Scott to M. H. C. Hermann, apiiculteur of Tamin by Clair, Canton Grisons, Switzerland; with whom Mr. Scott corresponded, and received from him in the month of October, 1859, two cassettes, each containing a Ligurian queen. One of these died on the journey; the other was successfully placed at the head of a strong English colony, and flourished at the commencement of the year 1860. It sent out a strong swarm on the 2nd of July of that year, with which Mr. Scott was greatly delighted, and of which Mr. T. W. Woodbury, of Exeter, afterwards remarked in a letter, 'I should think that this was the *first natural swarm* of Ligurians that had been seen in England.' But to the great regret of Mr. Scott they never swarmed again, for the gloomy summer of 1860 proved fatal to the race in his apiary; whilst Mr. Woodbury's, having been kept from swarming, survived and flourished.

About this time it was that the greatest advance was made in bee-keeping by the introduction of frame-hives; and in this matter also Mr. Scott had the great satisfaction of lending a helping hand. The famous *Practical Treatise on the Hive and Honey Bee*, by L. L. Langstroth, was published at New York in 1860; and came into Mr. Scott's hands in 1862. In the perusal of this most complete and exhaustive work, he became deeply interested, and at once set himself the task of constructing a hive something upon Dr. Langstroth's lines; but, as Mr. Scott thought, more suited in

size to our variable climate and short, uncertain summers, and he hoped also with some improvement of his own. This latter consisted in the tops of the frames projecting about an inch beyond the front and back of the box, so that the frames might be lifted out without having to lay hold of them within the hive. This hive when completed was described in the *Cottage Gardener*, No. 262, and Mr. Scott gave it the name of 'The Sibertswood Hive' and he allowed Mr. W. J. Pettitt, of the Apicultural Institute, Dover, to make and sell them as he pleased; and in the course of a few years many hundreds were sent into different parts of the kingdom with his own addition and improvement of the metal bar rest. A model of this hive, made of polished mahogany and plate-glass, was successfully exhibited by Mr. Pettitt in Paris, and, with equal success by Mr. Scott, at one of the great exhibitions in the Horticultural Gardens, London. A silver medal was awarded in each instance. It was about the same time that Mr. Woodbury brought out the hive which received his name, and which, in Mr. Abbott's hands, became, for a long time, a favourite with the public; but it may be mentioned here that the frame of the Sibertswood Hive was in size nearer the dimensions of the present Standard as determined by the B. B. K. A. than any other that had been before the public; and it is also worthy of remark that Mr. Abbott on one occasion spoke strongly in favour of a top bar which projected beyond the sides of the box, as the Sibertswood hive then did.

Besides these efforts in the cause of an improved system of bee-keeping, Mr. Scott delivered lectures on bees and bee-keeping before the East Kent Natural History Society (of which he was one of the Vice-Presidents) at Canterbury; before the Philosophical Institute at Dover; in the Town Hall of his native place, Folkstone, under the patronage of the mayor for the time being; as well as in his own and a few other village school-rooms. At this time also Mr. Scott became acquainted with all the known bee-keepers in the county, especially two distinguished individuals who were also writers on the subject of bee-keeping, named Major A. Munn, of Throley, and Dr. Edward Scudamore, of Bellevue, Harbledown; besides Mr. Golding, of Hamton, who has before been mentioned. Mr. Scott was also at this time introduced to Lord Keane, of Stetchworth Park, Newmarket, who had built himself a bee-house, which he assured him would accommodate eighty stocks of bees, exactly four times the number provided for in Mr. Scott's.

In the spring of the year 1868 he had a correspondence with Mr. T. W. Woodbury on the subject of a controversy which was being carried on between himself and Major A. Munn as to the first introduction of a frame-hive into this country, as well as of the Ligurian bee.—Major Munn taking credit of the first to himself, and giving Mr. Scott that of the latter, but without any decision having been come to on the former subject. A comparison of dates showed that Mr. Woodbury's first queen was 'despatched by Hermann from Tannin by Chur on the 28th July, 1859, the same day that he sent the first queen to Mr. Neighbour,' whereas Mr. Scott did not receive his until the month of October in the same year. Mr. Woodbury adds, in the letter quoted above, 'My queen lived and did well, whilst Neighbour's died; so that mine was certainly the first successful introduction.'

(To be continued.)

## Echoes from the Hives.

*Croesfield, Salisbury, Feb. 6th.*—The weather of the past two months has been very mild with the exception of a few stormy days. Bees on the wing almost every day, excepting when it was stormy. I took a look into one of my hives on February the 5th, and found several

large batches of brood in all stages and a number of young bees hatched out traversing the combs; the hive examined was a double-walled hive, but without any packing. Crocuses and other spring flowers in full bloom.—T. GILLES.

*East Dorsetshire, Feb. 9th.*—The weather continues here, as elsewhere, very mild and bees are flying most days, though as yet there is nothing for them to gather, snowdrops and crocuses not being open. But little honey, however, has been consumed, and as a rule my stocks have not yet commenced rearing brood, although last year at this time when the weather had been much more severe almost every hive had brood. I account for this by the fact that they are much stronger this year than last; and I have found by careful observation that the earliness of brooding is in inverse proportion to the strength of the stock. I am well aware that Mr. Cowan and other high authorities tell us the contrary; but then, even the highest authorities are not always correct in their statements, but are too apt to take things for granted, as for instance, in nearly every book on bee-keeping that I have seen, we are told that *bees* and poultry must be guarded against, or they will destroy large numbers of bees. Whereas the fact is that neither the one nor the other will knowingly touch a bee.—G. S.

*Sussex.*—Remarkable as was the mild weather of November and December, that of January has been still more so. Very frequently we have had it 50 degrees in the shade, while there has been but one or two slight frosts during the month. On the 24th, we had a heavy gale from the W. S. W., doing considerable damage; the wind lasting with great violence for three days, reaching its height at 8 p.m. on the evening of the 26th, when, as on the previous night at the same hour, it was accompanied with thunder, and vivid flashes of lightning. My simple covers have had a practical test. Though none of them were weighted, or fastened down, not one was blown off, while those of other shapes, with weights, were blown in all directions.—SAM'L. SIMMONS.

*Somerset, Spa Don.*—I think you may be interested to hear that I have a small Observatory hive in a bedroom window containing three bars. They have wintered, so far, exceedingly well, and have now (Feb. 8th) sealed brood in the outer bars and plenty of honey, and the bees are busy carrying in pollen. All the other hives in my apiary, numbering about fourteen, are doing well, plenty of sealed food; and though the bees have been so active all the winter, I think there is a fairly good number in all the hives. I am very much interested in Mr. Ditty's article upon extracted honey, and from my own personal experience of two or three years, find it pays much better than comb-honey.—MELLARTH.

*North Leicestershire.*—During the four weeks ending to-day (9th inst.), bees have been on the wing six times; on several other days, though the thermometer stood at 50 degrees, they remained under cover being probably influenced thereto by the prevalence of rough winds. On Feb. 1st, although the maximum temperature was only 44 degrees, the bees were carrying in loads of pollen of a light colour, most probably obtained from snowdrops. Since that date the weather has not tempted them abroad. Snowdrops, aconites, violets, and primroses, are in full bloom; and crocuses, arabis, and gillyflowers, are beginning to show their colour.—E. B.

*Blair Athole.*—The year 1883 will not be remembered by bee-keepers as one of 'lots of honey,' but as one that gave only a very moderate yield. Apiaries within range of the heather were fairly remunerative—I speak of my own locality—July and August were unusually wet; rain falling on twenty-two and seventeen days, making a total of 5.04 and 3.61 inches respectively. Temperature: July—Mean for month 13.7 C. (56.66 F.); mean highest,



187; mean lowest, 89; August—Mean for month, 13.0C. (56.4 F.); highest, 17.3; lowest, 8.7. January of this year (1884) was very mild; Temperature—Mean for month, 38. C. (98.88 F.); highest, 69; lowest, 0.72; rainfall, 5.13 in. Bees had some twelve days on which they could fly and are in splendid condition.—A. C.

*Cairnie-by-Kelth, N. B., Feb. 8th.*—Two weeks ago we had a sharp snow-storm, most of the snow has now disappeared and bees have been out very frequently. I examined two hives on the 6th inst., and found them just in the very condition I expected, viz., very little stores. I intend to give a 2-lb. cake of candy to each, liquid food is, of course, out of the question. Several people have already lost hives by starvation.—A. COCKBURN.

## Queries and Replies.

QUERY No. 740.—(M. J. ASHLE, *Water Mills.*)  
*Wetted Combs.*—I have five bar-frame hives standing in the garden, next to the mill dam, and owing to a sudden fresh of water, the bank gave way at a weak place, and flooded these five of my hives three inches over the floor-board, and, of course, must have lodged in the bottom of the combs to, at least, the depth of two inches. If the weather had been mild, it would have been an easy matter to get the water out; but the wind was much too chilly to warrant an interference with the frames—the cure would have been worse than the disease; all I dare do was to give them dry floor-boards, which, luckily, I had in readiness. Now do you think that the bees will be likely to suffer seriously from this unforeseen accident, either from dysentery, or mouldy combs? All—with one exception—have a good lot of sealed honey, and syrup, in the tops of the frames. If you could set my mind at ease, I should be thankful, but should, in any case, like to know the worst.—A. The wetted combs will certainly become mouldy, and unfit for use, but you need not fear dysentery in this mild weather, when the bees have so many opportunities of flying. We should take advantage of the first fine day, to open and examine the hives, and cut out the lower part of each comb, so far as the damp has risen, remove all combs not covered by bees, close up the division-board, and feed about a gill of warm syrup with salicylic acid. When the bees get strong, they will soon rebuild the removed portions of comb. It would be desirable that the bees should be shifted into dry hives.

QUERY No. 741.—(STRAWHIVE).—*Supers and Swarms.*—I have a number of bees in bar-frame hives last year's swarms and wish to still increase my stock of bees. Can I put a super on a hive that I wish to swarm artificially; and if so, must the super be put on *before* or *after* the swarm is forced? A. You cannot reasonably expect supers, and an artificial swarm, from one hive, unless very strong. If you can build up a stock so strong as to bear swarming from, and still leave a large population, you may get both. If you can get a super filled before you make your swarm, do so. When you make your swarm, cut out all queen-cells but one, to prevent a cast issuing, reduce the size of the hive by closing up the division-board, and as the bees will have no brood to attend to, and the young bees will be hatching rapidly, you may get another super filled—always supposing plenty of honey is coming in.

QUERY No. 742.—(AMATEUR).—1. *Super Honey.*—Would you kindly tell me the best way to procure super honey from frame-hives without a possibility of swarming? as I have to keep them at a distance from home.—A. We, and most other bee-keepers, would be glad to know how to 'procure super honey without the possibility of swarming.' Your best plan will be to confine the queen on two or three combs, between two sheets of excluder-zinc. Cut out all drone comb from the enclosed combs.

2. *Stewarton Bees.*—Would putting Stewarton honey boxes on an ordinary bar-frame hive prevent swarming?—A. Stewarton honey boxes are not suited to bar-frame hives, a crate of sections would be better.

3. *Salicylic Acid.*—How much powdered salicylic acid should I use (to prevent foul brood) in syrup for spring feeding, and is the enclosed the right sort?—A. Make a solution of 1 oz. of salicylic acid in half gallon of water, with a little borax, without which the acid will not dissolve. Use of this solution 1 oz., or two tablespoonfuls, to each 10 lbs. of sugar used for food. The sample you send is correct.

4. *Sugar for Feeding.*—I notice that one of your experts sells cane sugar for feeding, what do you think of enclosed sample?—A. The sample of sugar you send is not so good for food as the refined lump, or crystal.

QUERY No. 743.—(THEA, *Manchester.*) 1. *Commencing Bee-keeping.*—I am about to start bee-keeping, and propose to have a swarm in May next, and to place it in one of Abbott's Irish hives. Is it necessary to have waxed frames or comb foundation ready fixed in the hives? Will it be necessary to commence feeding *immediately* the swarm is hived? In extracting honey from comb containing brood is there not a great risk in chilling the brood or destroying the larvae? A. By all means use comb foundation, and having hived your swarm continue feeding for several days, when, if the weather prove fine, and honey comes in fast, cease feeding, and place on your hive a rack of sections, which, if the season be favourable, ought quickly to be filled, and sufficient honey for the winter's supply stored in the combs below. By extracting from brood-combs there is a risk of chilling the brood and injuring the larvae. We never practise it, as little honey is stored in the centre combs where brood is chiefly raised, and that little we leave for winter's use.

2. Can you give me the name of any bee-keeper within easy distance of this, who would be willing to let me visit his place, and give me a few hints? A. Perhaps the veteran apiarist, W. Carr, Esq., Newton Heath, Manchester, would not be disinclined to receive a visit from you, and discuss bee-keeping with you.

3. Can you give me the name of the secretary of the Lancashire Beekeepers' Association, or the name of any other officer with whom I can communicate?—A. J. P. Jackson, Esq., care of Gibbs & Co., 4 Moorfields, Liverpool, would give you the information you desire respecting the Lancashire B. K. A.

QUERY No. 744.—(J. W. TOWNSEND.) *Melting Wax.*—Would you be so kind as to tell me the best way to make beeswax from old combs; also the safest way to introduce a Ligurian queen into a high-bred stock, and how soon can this be done safely?—A. To melt wax, if only a small quantity, having broken up the combs, fit them loosely in a bag made of cheesecloth, or canvas, and place it at the bottom of the pot or caldron, with a weight upon it to keep it down. Fill the pot with water, and boil until the wax escapes from the bag and rises to the top. The whole may then be set aside, and when cold the wax will be found in a solid mass and the refuse in the bag below. We do not advise the introduction of queens before April. Consult *Queen Introduction* by Rev. G. Raynor, price 3d., to be had of Mr. J. Huckle, King's Langley.

## NOTICES TO CORRESPONDENTS & INQUIRERS.

R. PIGG, *Norton.*—The sample of honey forwarded has a nice flavour. The process adopted by you may retard, but will not prevent, granulation. Some honeys are more subject to granulation than others. The sample shows signs of granulation. There is nothing, however, in the condition of the honey that renders it unfit for exhibition.

D. H. SIDBALL, *Tadmorden*.—We would recommend for your study Cowan's *Bee-keeper's Guide-book*. You will find in its pages the information you desire respecting the measurement of hives, and the management of bees in bar-frame hives.

E. R. BRECON.—1. *Bees breeding*.—The extraordinary mildness of the season has set all nature, bees included, at work earlier than usual. The scarcity of food is caused by the breeding going on, and you must keep up the feeding, or the brood will be starved and much harm done. 2. *Feeding*.—By all means give syrup. Candy does not contain sufficient water for the sustenance of brood, and the bees are forced to leave the hive in quest of this necessity, and are lost and worn out. Refer to the 'Useful Hints' in issue of February 1st.

SAM'L GILBERT, *Dorset*.—*Monthly Combs*.—You ought to have kept your removed combs in a dry place to preserve them from mildew, but, having become mildewed, you did the best thing you could. You may safely give the combs to your bees. You may do so now, putting them outside the division-board and unsaling the honey. When brood has hatched, and the bees are crowded on their present combs, you can put the spare ones, one at a time, in the middle of the brood-nest. The powdery pollen has probably been attacked by mites, but the bees will clear it out, or you can blow it out. If you intend to extract, your drone-combs will be usefully employed as you suggest. You may commence stimulative feeding now, but read our 'Useful Hints' Feb. 1, and do not be too eager. We are not 'out of the wood' yet.

A SUBSCRIBER.—*Transferring Bees from a Box-hive*.—To transfer bees from a box-hive to a bar-frame, it is not necessary to drive the bees. Open the box, sever the attachments to the sides with a knife, lift out one comb at a time, and brush the bees off it into the box. Tie into the frames, and when all the combs are thus transferred to the bar-frame hive, brush or throw the bees among the combs. The bar-frame hive should be stood upon the stand of the box-hive during the operation, and all the bees which take wing will enter it. Do not attempt it until the weather is warm, and be careful not to chill the brood by having it uncovered by bees too long.

ERNEST HAYWARD.—To transfer bees from a straw skep to a moveable comb hive, the process called 'driving' must be adopted. The mode of driving is explained in *Modern Bee-keeping*, page 55. The best time for a novice to transfer his bees is about three weeks after swarming; the experienced bee-keeper may do so almost at any time with success. For 'Transferring' see p. 59 of above-mentioned book.

SUBSCRIBER, *Etihad*.—From your description of the locality, we think it would supply forage for forty or fifty colonies of bees. Five years' experience with eight or nine hives should well qualify you for the venture, and a successful result. The 'yellow-flowered rape,' of which you speak as growing like a weed amongst corn, is, we imagine, the charlock, or wild mustard, which is an excellent bee-plant, yielding both honey and pollen in considerable quantity. The coltsfoot (*Tussilago farfara*) is also very useful to the bees in early spring.

A. C.—The barley-sugar, as made in accordance with the recipe in pages 67 and 68 of *Modern Bee-keeping*, may be given advantageously to bees for the purpose of eking out their winter stores. This is to be preferred to that obtained at the grocer's, which is very variable.

BRESWING.—*Foul brood*.—The bees Mr. Simmins had at the time of his experience with foul brood, were

Ligurians, hybrids, and blacks, and all alike were victims to the plague. Mr. Root's bees are certainly nearly all Ligurians; but other larger apiaries of all blacks or hybrids are equally exempt from the disease. In fact, the nature of the complaint is such that no variety of bees can be proof against it when the germs of the plague are at hand. Mr. Ditty's bees are the common black bees.

JOHN J. SMYTH.—*Plans for Bee-houses*.—We purpose, in an early number, giving plans and specifications for bee-houses.

A. COCKBURN writes:—*Honey house*.—I intend to build a small house for holding honey, hives, and other appliances. I would be delighted to have a description of the size and shape most suitable. Perhaps some of your readers will give us an article on the subject.

X. Y. Z.—*Transferring*.—In your case we should not transfer at all, since the greater part of the comb will be useless from age, granulated honey, old pollen, &c. Allow the hive to swarm, and place the swarm on the worked-out foundation, feeding it for two or three days; and then, removing the feeder, give a rack of sections in place of it. Twenty-one days after the swarm has issued, drive all the bees out of the old skep, put them on five or six frames of foundation in a frame-hive, and place them on the old stand. With favourable weather they will make you a second good colony. If, however, you determine to transfer, do not attempt it before the end of March or even April. The operation will be much better performed then than earlier, because the combs will be lighter, from the granulated honey and old pollen having been cleaned out. The brood and the worker-comb only should be preserved, and supplemented with frames of foundation to fill up the hive, and later in the season a rack of sections might be given. By the former plan, which we much prefer, you would obtain two good stocks and surplus honey; by the latter, only one in all probability.

F. ZERETMAYR.—*Incredible, and yet True*.—We are obliged by your translation of Dr. Dzierzon's report on the fact of Pastor Schönfeld's observation of the attachment of a drone to a worker-bee, as recorded in the *Bee Journal* for Oct. 15, 1883, and perfectly concur with him that this solitary and imperfect observation 'does not prove anything at all, and much less still will it be able to shake or throw doubt upon the theory of the origin of the drones, established through the experience of practice, and through the minute study of scientific men with microscope and dissecting needle.'

MELLARIUS.—Respecting the proper person to apply to for a black queen, we should prefer your getting the information you desire from those who deal in queens, as we are indisposed to mention the name of any special dealer. We do not recommend the introduction of queens before April.

F. A. GOODALL.—See reply to 'Ernest Hayward.'

T. L. W.—1. *Strength of Stocks*.—If on the 1st of March there are four or five frames covered with bees the stock may be pronounced to be fairly strong. 2. *Climbing Annual Plant for Bees*.—The nasturtium, flowering for a long time, and yielding a large percentage of honey, may be recommended. Bees are very partial to scarlet runners. The sweet pea and convolvulus are not frequently visited by bees.

JOHN BERRY.—If the bee-keeper is not afraid of work he will find that, by the aid of the 'Little Wonder' extractor, he is able to extract all kinds of honey, with the exception of heather honey.

*Some replies are reserved for next issue.*

**Special Prepaid Advertisements.**

For Sales and Purchases of Bee Appliances, Honey, Books, Pamphlets, Diagrams, &c., Exchanges and Situations.

*Terms: Twelve words and under, Fourpence; for every additional three words, One Penny extra; no reduction can be made for continuous insertion.*

Advertisements will not be received for insertion under this heading from Manufacturers or Dealers in Bee Furniture, except for the Sales of Honey and Bee Literature.

**SPECIAL NOTICE.**—We cannot under any circumstances be responsible for the truth of statements made in Advertisements, or for the trustworthiness of either Buyers or Sellers.

**THE SIMMINS' METHOD OF DIRECT INTRODUCTION.**—Enlarged to 32 pages. Price 6d. Post free. of the Author, Rottingdean, Brighton; Messrs. NEIGHBORNS & SOSS, 119 Regent Street; and Mr. J. HECKLE, King's Langley, Herts. (53)

**FULL Pollen in Autumn.**—Sunflower Seed 3d. per packet, post free. Address Mrs. HONY, Bishops Canning, Devizes. (A 60)

**TIN FEEDERS** for placing on hole of quilt. Perfectly safe, no robbing—will take much or little—no loss of Bee-life. Can be filled at any time without annoying the Bees. Post free, 1s. 3d. Address J. KENNEDY, Comber, Co. Down. (A 61)

**NEW PERSIAN CLOVER**, highly fragrant, and a valuable Bee Flower. Very scarce. In small packets, 1s. each. Cash with order. Address R. R. GORDON, Grantliam, A 62

**BEEES (Hybrids).**—Thirty-five strong Stocks for Sale, in Bar-frame and Skep Hives, from 10s. to 18s. Also a few empty Bar-frame and Skep Hives, Bee-houses, and other appliances, to be sold cheap. *British Bee Journal* from the commencement. Address HATLEY BROS., Laurel Cottage, Sheffield, Dasingstoke. (A 63)

**WANTED.**—Abbott's Leads (s. 2, 7, 10, 11, 12. *Bee Journal*, May to September, 1882, inclusive. Address MAJOR, 2 Nicholson Road, Croydon. (A 65)

**WINTER LECTURES.**

For Sale on Hire

A SET of LANTERN SLIDES suitable for illustrating the subject.

For further Particulars and Specimens address—

**ABBOTT BROS.,** Southall, Middlesex.

**CHINA HONEY BOXES and JARS**, as sold at the Knightsbridge Show, may be obtained of Mr. J. HECKLE, King's Langley. The Boxes are suitable in size for holding 1 lb. Sections, and the Jars about 14 lbs. of Extracted Honey, both are very ornamental and convenient for the Breakfast Table. Price reduced to Boxes 2/6, Jars 1/0. Can be forwarded by Parcels post on payment of the cost of carriage, amounting to 6d. for one Box; two Boxes, 9d.

**METAL ENDS FOR FRAMES.**

**NOTICE.**—We beg to call the attention of all Bee-keepers to our latest improvement in Metal Ends for Frames, which entirely supersedes the use of Zinc Runners and Broad-shouldered Frames, while their weight and fixing keep the Frames perfectly perpendicular.

Price, 10d. per doz., 9s. per gross. Specimen sent on receipt of 1s. stamps. All Hives above 10s. each are fitted with these Ends.

Illustrated Catalogue free on application. Silver Medal, Knighted 1883. First and Second Prizes at H. Exhibition, Crystal Palace.

**C. G. HARRISON & CO.,**  
Hive Makers and Dealers in all Apianian Appliances,  
HALESOWEN, WORCESTERSHIRE. 1848



**HOGES HONEYHOUND**

For Coughs, Sore Throats, Hoarseness, &c.,  
Testimonials from the World's Fair, London.  
"I have much pleasure in stating that I consider your Honeyhound Honey to be the most wonderful remedy I have ever tried, in soothing properties which are not only short of many others for the cure of affections of the throat and chest."  
(Signed) "MARIE ROZE MARTELL."  
Price is 1/6 per bottle. Sold guaranteed.  
W. M. HOSE & CO., LEONARD ROAD, LONDON, E.

**THOMAS B. BLOW,**  
WELWYN, HERTS.

Manufacturer of Bee-keeping Appliances of every Description,  
And IMPORTER OF FOREIGN BEES.

**BEGS** to call attention to the unrivalled quality of his productions. By the aid of special power machinery he is enabled to combine moderate prices with high quality. More lowness of price is not so much aimed at as accurate fit and finish, all goods being adapted both for the convenience of the Bees and ease of manipulation to the Bee-keeper.

**ILLUSTRATED CATALOGUE**, 48 Pages, 50 Illustrations, full of interesting and useful information, Free on application.

**THE HEREFORDSHIRE**  
**SCHOOL OF APICULTURE**

**SUPPLY BEES, HIVES**, and everything pertaining to Modern Bee-culture. HIVES made only of the best well-seasoned wood, a quantity of which is always kept ready cut and prepared for putting together.

Awarded *Honourable Mention* for a Hive exhibited at COLEMAN STREET EXHIBITION, 1883, and *First Prizes* at various County Shows. Revised Catalogue for 1884.

**J. R. W. HOLE,**

(Lecturer) H. B. & K. A. & S. & C. & B. K. A.  
4, LITTLE ST.

Address TARRINGTON, LEDBURY.

**CHARLES T. OVERTON,**

President of the Sussex Bee-keepers' Association.

**THREE BRIDGES, SUSSEX,**

Begs to call the attention of all Beekeepers to his **NEW STOCK OF BEE-KEEPING APPLIANCES** for 1884, and hopes to be favoured with their support.

See, and Know, Metals, and other Prices, awarded at *Woolwich, Knighted 1883, H. B. & K. A. & S. & C. & B. K. A.,* and other Shows, to the *Best Bee Hives, Hives, Smoking, Supers, E. Tools, Comb Foundation, &c.*

Orders can now be booked for Prime Stocks, and Swarms of ENGLISH, LIGURIAN and other Foreign BEES, for early spring delivery, also Import of LIGURIAN QUEENS. First consignment will arrive early in May.

**SPECIALITIES.**

The **CROWN HIVE**, and Extra for Bin-dwelling Smokers, the best in use; Supers; Honey Racks; Comb Foundation, American 2 lb. and 1 lb. Sections; **FLAT TOP STRAW HIVES**, with hole in top for feeding and supersing, 2, each; Crates of 18 1 lb. Sections for Straw Hives, &c. each, complete.

Questions of Bees and their Management answered by return of post, 2d. stamps. Send 7d. for *Modern Bee-keeping*, 1s. 6d. for *British Bee-keepers' Guide*. Catalogue free on application.

**THE BEST BEE FEEDER** for Autumn use is **BUTT'S NEW FEEDER**, made of White Stone China, the merits of which were fully described by the Editor of this *Journal* in the issue of June 1st, p. 43. Among other advantages, this Feeder is so constructed as to admit of the Bees feeding readily, and with perfect safety; and the loss of heat to the Hive (a fault common to many Bee Feeders) is entirely obviated. Being made of white ware it can be more easily cleaned than either zinc or tin, and keep the food sweeter and fresher, and cannot rust. This Feeder has been tried by many experienced Bee-keepers and Experts and pronounced perfect. Sent post free to any address for 3s. 6d. Trade price on application. **ERWYN J. BUTT**, Manufacturer of Bar-frame Hives and Apianian Appliances, Scotland House, Barnstaple. (12)

# W. M. HOGE & Co.,

## Dealers in Honey and its Bi-Products.

**I**MPORTERS and REFINERS of FOREIGN HONEY, and Packers of PURE ENGLISH HONEY. Manufacturers of HONEY WINE WAXED PAPER, DENTAL WAX, SHEET WAX for FLOWER-MAKING, WAX FURNITURE POLISH, &c., &c., and Proprietors of

### HOGE'S HOREHOUND HONEY.

ENGLISH HONEY purchased at the highest Market price, and liberal Cash advances made upon Consignments of Foreign Honey and Beeswax. We always have outlets for Honey and Wax.

CORRESPONDENCE SOLICITED.

City Offices: 64 King William Street.  
Telephone Numbers: 242 and 1359.

Honey Refinery: Leconfield Road, N.  
Cable Address: 'Sturdy, London.' (16)

# THE BRITISH BEE JOURNAL.

VOL. XI., MAY—DECEMBER, 1883.

*Containing 300 pages of Useful and Instructive Information to all Classes of Bee-keepers.*

IT IS ACCOMPANIED WITH A COPIOUS INDEX.

The Contents include Papers on—Hives: Twin, Triple, Stewaton, Observatory, Anglo-Cyprian, Cheap, Single and Double Walled, Skops—Bees: Blacks, Ligurians, Carniolans, Cyprians, Holy Lands, Syrians, Humble and Wild—Honey and Wax—Feeding, Extracting, Queen-raising and Introducing, Nuclei, Uniting, Bee-farming—Bee-stings and their Remedies—Bee Flowers and their Names—Candy, Syrup, Sugar-cake—Smokers and their Fuel—Lectures—Reviews—Useful Hints from Month to Month—Correspondence on all Apicultural Matters—Queries and Replies—Notices to Correspondents—Reports of Associations, Shows, and Honey Fairs—Bee-culture in Europe, America, India, Australia, &c.—Translations of the best Articles in Continental Bee Periodicals—The Zurich Exhibition—Papers read at Conversations—Biographies of Celebrated Bee-Masters—Descriptions of Apiaries—History of County Associations—Reports of the Bligh Competition—Presentation of Testimonial to Mr. Abbott, &c., &c., &c.

Neatly bound in Cloth, price 7s.; post free 5s. 6d. Cloth Covers for binding the Volume, 1s. each.

*All the back Numbers of this Volume are still in print.*

Vols. 6, 7, 8, 9, 10, and 11, price 5s. each, post free 5s. 6d. may be obtained of J. HUCKLE, KING'S LANGLEY, HERTS; KENT & Co., PATERNOSTER ROW LONDON and all Booksellers.

**F**OR FINEST IMPORTED QUEENS, see last Number of *British Bee Journal*. Address FRANK BENTON, Munich, Germany.

**Q**UANTITY of BOX-WOOD BLOCKS for Bee-Furniture Catalogue, at half-price. Apply to Mr. JOHN HICKLE, King's Langley, Herts.

**S**UPERIOR BEE-VEILS, Wire Gauze Fronts, 1s.; three for 2, 9d., post free. Splendid BARLEY SUGAR CAKES, in 8 lb. Tins, 3s. 9d. Address W. CRISP, Halstead.

**S**ADDLER'S TABLET is the best SPRING FOOD for BEES, either with or without Flour. 1 1/2 lb. per lb., or 40s. per cwt. With Salicylic Acid to order. Address 31 East High Street, Forfar.

**W**ANTED, a competent Man to MANAGE a BEE-FARM on a large scale. For particulars apply to THOMAS B. BLOW, Welwyn, Herts.

**W**ANTED, an EXPERT for the Hants and Isle of Wight Bee-keepers' Association, to arrange a SPRING TOUR, &c. Good Testimonials indispensable. A permanent Salary could be secured by anyone who would assist in duties of Assistant Secretary, &c. Residence near Christchurch, preferred. Apply to E. H. BELLARS, Hon. Secretary, Wingfield, Christchurch.

### HEAD QUARTERS

FOR

## Comb Foundation, Sections, &c.

For PRICE LIST apply to

WILLIAM RAITT, Blairgowrie, N.B.

**I**LLUSTRATED CATALOGUE Free anywhere. Pure Foundation, 2s. 1/2; 5 lbs. at 1s. 10d. Best Sections, 1s. 10d. Superior Combination Hive, 24 ins. long, 8s. Prizes awarded to G. STOTHARD, Welwyn, Herts, at Fourteen Shows. 1842

### E. M. HART & CO.,

The LONGSTOCK HIVE Manufactory,  
STOCKBRIDGE, HANTS.

#### SPECIALITIES:

HIVES, complete, from 6s. SECTIONS, V-cut, in 6 sizes. FOUNDATION, Flat, or natural based.  
CLARK'S COLD-BLAST SMOKER. 'Far and away the best Smoker.' 3s., post free.  
HART'S SIMPLEX FEEDERS. 'The easiest and best to manage.' 1s. 6d. each, 15s. dozen.  
THE 'SWANMORE' SECTION CRATE. 'The most perfect Crate made.'

**The Trade supplied. Price List on application.**

## BEE HIVES and APPLIANCES

Of the best quality, at the lowest possible price, to be obtained from

**JOHN LEAKE, JUN.**  
BEACON STREET, LICHFIELD.

COTTAGERS' HIVE, made of 1-inch best Pine, planed outside, contains 9 Standard Frames and Dummy, resting on Tin Runners, suitable for Bee-Shed. Price 4s.

ABBOTT'S HONEY EXTRACTOR, best make, 9s. 6d. BINGHAM SMOKER, neatly and strongly made, 3s. 6d. Other Appliances at an equally low rate. 5 per cent. discount of all Orders up to April 1st.

Send Card for PRICE LIST to

JOHN LEAKE, Jun., Beacon Street, Lichfield. 1848

# THE BRITISH BEE JOURNAL

Communications to the Editor to be addressed 'STRANGWAYS' PRINTING OFFICE, Tower Street, St. Martin's Lane, w.c.'

[No. 141. VOL. XII.]

MARCH 1, 1884.

[PUBLISHED FORTNIGHTLY.]

## Editorial, Notices, &c.

### BRITISH BEE-KEEPERS' ASSOCIATION.

#### THE PROPOSED TESTIMONIAL TO THE LATE HONORARY SECRETARY.

Mr. Peel having (as announced in our issue of Feb. 1st) declined to accept any personal testimonial, the Baroness Burdett-Coutts, President of the Association, has expressed her wish, through the Secretary, that the Committee of the British Bee-keepers' Association should, in conjunction with the honorary secretaries and representatives of the several County Associations, take into consideration the best means of complying with the wishes of the members as expressed at the Annual General Meeting, and to make such arrangements for the collection and disposal of the fund as they think will best tend to promote the usefulness of the British Bee-keepers' Association.

### COUNTY EXPERTS.

The President of the British Bee-keepers' Association, the Baroness Burdett-Coutts, called the attention of those present at the General Meeting on Wednesday the 20th of February, to the great importance of maintaining the existing County Associations in full vigour and efficiency, as well as to the importance of forming Associations in the counties which do not as yet possess them. One point connected with these Associations has been, in our opinion, most opportunely brought out recently by a controversy which has been carried on in the pages of the *Journal* between the Rev. George Raynor and a correspondent signing himself 'Platlayer, Ruckinge, Ashford.' The 'Platlayer' suggested, in the first instance, that County Associations should hold examinations at some convenient time and place to labourers who wish to obtain a certificate of competency in bee-knowledge and bee-management. This suggestion was accompanied, unfortunately, by an ill-judged and an deserved fling at the Parent Association. 'It is

well known,' the Platlayer affirmed, 'that the Parent Society does give certificates to qualified experts who can give a stump lecture to a hall full of people.' Why a stump lecture, O Platlayer? and why to a hall full of people? Never before the Knights-bridge Exhibition in the summer of 1883 had the candidates for the certificates of the British Bee-keepers' Association delivered their lectures in public, and then only of their own free will, those who preferred it speaking to the examiners in private. The 'Platlayer's' contention is that labourers who cannot deliver 'a stump lecture' should have certificates of proficiency granted to them. Mr. Raynor very properly points out that the successful candidates at the Examinations of the Central Association are arranged in three grades, and thinks it undesirable to descend below this scale. A labourer who cannot give a lecture, stump or otherwise, may very possibly gain a third-class certificate if he displays a competent knowledge of bees and their management. A third class certificate, if the present Standard of examination is not lowered, should ensure the holder all that the 'Platlayer' asks for, viz. 'a better chance of getting a good situation;' but he must not expect to be engaged to speak in the bee-tent at the county or any other show if he cannot speak in public, and he must leave that office to experts who hold a first or second-class certificate. There seems no reason then for levelling down the certificates so as to include a lower grade of experts. But to our mind there seems great force in the 'Platlayer's' suggestion that examinations should be held at convenient times and places without the candidates being brought up to London for the purpose. A letter, which we publish in this issue, from the Hon. Secretary of the Carmarthenshire Association, seems to point in the same direction. After calling attention to the want of local experts which is so greatly felt by many of the County Associations,\*

\* A letter from a correspondent states:—'I consider that it will be most advisable for the Committee to extend their arrangements for the examination of candidates; the demand for experts is already considerably in advance of

Mr. Oswald Lewis points out that in Wales this want is more especially felt from the fact that a large number of the members of Welsh Associations speak the Welsh tongue, and understand no other language than their own. The gist of Mr. Lewis's letter is that experts are greatly required in Wales as elsewhere, and that these experts must speak the Welsh language. Now how is this difficulty to be met? It is clearly useless for an English expert, even of the first class, to deliver a lecture to an audience of Welshmen who do not understand a word of English. 'He that speaketh would be a Barbarian unto them.' In proof of this we would refer our readers to the letter of 'Iardus,' who, hailing from the dales of Durham, uses a similar argument. He says, 'If an expert from the south were to come up amongst these dales, he would not understand the people, and I don't think they would understand him.' 'Platlayer's' first suggestion seems to come in very opportunely here, and our best thanks are due to him for it. Why should not local examinations in the knowledge of bees and their management be held at convenient times and in convenient places on the principle of the Oxford and Cambridge Local Examinations? In these examinations the papers are set by a central board of examiners, who appoint a local representative to 'invigilate' or superintend the examination, and send back the answers to the central body in order that they may be marked by them according to the standard which they adopt. 'It is important,' writes one well qualified to pronounce on this subject, 'that the questions should emanate from the central body, and that the answers should be marked by them, in order to keep the standard of marks uniform.' Why should not a system of local examinations be adopted by our Central Association? England and Wales might be divided into districts, and experienced bee-masters appointed to receive the papers set by the central committee, and to superintend the examination. The papers might be translated into Welsh for the benefit of those to whom Welsh is the mother tongue, and the *visu et voce* examination could be conducted in Welsh when that was necessary. Difficulties will of course present themselves; but none, we imagine, which will be insurmountable. In this manner the suggestion of the 'Platlayer' may be adopted without lowering the value of the certificates. Examinations might be held at any number of different places at the same time, and an additional impulse given to the County Associations, according to the President's advice, whilst an additional proof will thus be given of their usefulness.

The question as to whether there should be three grades of certificates or only two, we must reserve for another number. At present we see no advantage in altering the existing arrangement.

the supply. Very recently a large fruit-growing farm has been established in Gloucestershire or Warwickshire (I am not quite sure which), and in connexion with it a large bee-farm. The arrangement of the latter has been placed in Mr. Blow's hands; and he has not been able to get a man in England, but has secured one from Ireland.

### COUNTY ASSOCIATIONS.

Reports of several County Associations for the past year are to hand. We purpose giving a statement of the number of Members of each Association. The following is the list already received:—

ASSOCIATION.	MEMBERS.	ASSOCIATION.	MEMBERS.
Sussex . . . . .	301	Surrey . . . . .	160
Kent . . . . .	300	East of Scotland . .	144
Hertfordshire . . .	295	Leicestershire . . .	127
Buckinghamshire . .	238	Berkshire . . . . .	120
Norfolk . . . . .	234	Hampfordshire . . .	112
Wiltshire . . . . .	190	Staffordshire . . . .	112
Essex . . . . .	186	Yorkshire . . . . .	95
Dorsetshire . . . . .	177	Brecon . . . . .	72
Worcestershire . . .	176	Huntingdonshire . .	60
Derbyshire . . . . .	170	Somerset . . . . .	67
Cornwall . . . . .	166	Shropshire . . . . .	52

In order that the volumes of the Reports of the Affiliated Associations may be bound and placed in the hands of the County Secretaries, it is desirable that the following counties should forward their Reports without delay, viz., Cheshire, Cambridgeshire, Carmarthenshire, Devonshire, Hampshire, Lancashire, Lincolnshire, Northamptonshire, Oxfordshire, Suffolk, and Warwickshire.

Persons desirous of assisting in the formation of County Associations in the undermentioned counties are requested to send in their names and addresses as follows:—Cumberland, Mr. J. Bolton, Fairview, Howard Street, Penrith; Mr. T. E. Highton, Keswick; Mr. Drinkall, 57, Castle Street, Carlisle. Pembrokeshire, Mr. H. A. Hicks, Rock Cottage, St. Thomas's Green, Haverfordwest.

### USEFUL HINTS.

With the month of March the active season of bee-keeping, at any rate in the south of England, may be said to commence, and stocks may be stimulated to produce brood, and so be ready for the harvest when (if!) it comes on. Every precaution must, however, be taken to prevent loss of heat and possible chilling of brood. See Hints for February.

EXAMINATION OF STOCKS should be undertaken at the earliest opportunity, choosing a warm fine day with little wind. When lifting the frames hold them over the hive so that any bees which drop may fall among the other combs and not be lost by falling upon the cold ground. Take off each layer of quilting separately, and destroy all grubs of moth which will very likely be found between them as well as upon the frames under the quilt. The clefts made in the top bars to receive the foundation afford special harbours for these pests. Scrape and clean floor-boards from all rubbish and traces of moth grubs. In long hives this can easily be done by shifting the frames to one end and then to the other. In hives which are filled with frames they may be lifted out bodily into another hive by putting strips of wood under the frame ends. Examine the amount of stores, and remember that when breeding commences consumption is very rapid, so that stocks apparently well supplied may in a few weeks' time be starving. Barley sugar is the best food to give newly stocks when the weather is cold.

**WEAK STOCKS.**—Stocks may be found weak from a variety of causes. If drones are found remaining it is a certain sign of queenlessness, and any stock without a queen must be united to another without delay. Also if the queen is known to be an old one it would be as well, if there are but few bees, to unite to another stock. If, however, the queen is young, even a small lot may, and probably will, build itself up into a strong colony. If weakness arises from disease, either foul brood or dysentery, which often leads to it, leave alone for the present, and do not risk spoiling another stock by trying to strengthen it. In all cases reduce the size of the hive by removing superfluous combs, and feed if necessary.

**SPREADING THE BROOD.**—This, if carefully done, will be the means of increasing the amount of brood to an extent almost incredible to those who have not tried it; but it must not be attempted until there is plenty of brood hatching, and a large population sufficient to well cover the brood in case of a cold snap occurring. Many bee-keepers do not rightly understand the theory on which this practice depends. The brood-nest is approximately of a globular form, and if we disturb it the bees will reproduce the globe; *a, b, c, d*, Fig. 1, represent four combs containing the brood-nest, shown by the shading.

If we take *d* and place it between *b* and *c*, as Fig. 2, to preserve the globular form *d* will be



Fig. 1.



Fig. 2.

filled, and *c* will also be partly filled, as shown by the dotted line. When *a*, being placed between *b* and *d*, the same rearrangement will take place on the other side. Thus, by placing the partly-furnished outside combs in the middle, a much larger quality of brood is produced than if the bees are left to their own devices. It is obvious, however, that more bees are required to cover the brood in its altered form as Fig. 2, hence the danger of being too eager in the matter.

**APPLIANCES.**—Give your orders for these this month, if not already given.

**SPARE COMBS.**—These will shortly be required; look over them, and if inclined to be mouldy, spray or brush with salicylic acid solution. Cut out all trails of wax-moth, and submit combs with any trace of it to the fumes of burning sulphur in a box.

**ROBBERIES.**—Prevent, by reducing the size of entrances; be careful not to spill syrup about when feeding, and to cover all bottles so that no taste of food can be got, which excites the desire and the tendency to search for more.

**WASPS.**—Destroy every one seen. Those now found are the queens, and every one allowed to live will be the mother of a colony later on.

**RECORDS.**—Now is a good time to commence to keep a record of the history of each hive. It may be easy to remember all about two or three hives, but not so easy when a large and flourishing apiary is established. Each hive should have a number or letter, and a tablet bearing that number or letter attached to it, on which memoranda may be made of the stock at a particular date, amount of food given, when swarmed from, age of queen, when supered, and so on. The most trivial addition or removal should be entered, and the information thus acquired will some day be found useful and instructive.

#### NEW PERSIAN CLOVER AS A BEE FLOWER.

I have been asked for information concerning the new Persian clover, of which I have already spoken hopefully as a bee flower, and I have much pleasure in complying with the wish of your correspondent. Three years ago I received a small packet of seed from abroad marked 'Persian clover, with the scent of orange blossom.' The description was promising, and the seed was carefully sown in my trial ground in the month of April; and although but few plants were raised, I was encouraged to continue the experiment of its cultivation by the freedom of growth of the plant, and the very marked, distinct, and delightful fragrance of the small pink flower heads, and their attraction to bees was unmistakable. A second trial with increased quantities of seed resulted even more satisfactorily, as the plants continued to produce their fragrant blossoms throughout the summer and autumn months; and although other kinds of flowers of a tempting nature were growing in profusion around, the clover was never without its attendant honey bees. The individual flowers in the heads of bloom are small and open, and accessible to bees. The plant grows rapidly, and produces long succulent stems, which rest on the ground, and seem almost to suggest supports, and this might be done in small gardens where space must be economised; but this I have not tried, independently of the interest of this clover as a bee flower, its fragrance should commend it to all who love sweet smelling plants; and when its flowering season is over, it may be cut and dried and employed to feed stock. I found that my horse evinced a decided preference for it in its dry state. W. INGRAM, *Belvoir*.

BENJAMIN FRANKLIN'S OPINION OF AMERICAN HONEY.—Colonel A. S. M. Morgan, of Pittsburgh, has in his possession the following hitherto unpublished letter: 'Philadelphia, January 8th, 1787. Mr. John Morgan, Sir: I find myself greatly obliged to your good Father for the Hive full of Honey which he has so kindly sent me, and to you for thinking of me and proposing it. I use it as a Part of my Regimen every Morning at Breakfast. It is much the best I have met with in America, and I think fully equals the famous Honey of Narbonne, so much esteemed in France. With my hearty Thanks, please to present him with my best wishes for his Prosperity, and many happy Years to you both, in all of which this Family joins me. I am, Sir, Your most obedient Servant, B. FRANKLIN.'

## BEE-KEEPERS AT HOME.

No. V.—THE REV. F. T. SCOTT, AT HARTLIP  
VICARAGE, SITTINGBOURNE.

(Continued from page 70.)

Having laboured in the cause of bee-keeping for a period of twenty-one years, Mr. Scott exchanged the preferment of Sibertswood for that of Hartlip, near Sittingbourne. His pets, of course, accompanied him in his change of residence, most of them occupying Sibertswood hives, with the exception of one which occupied a frame-hive of Ibscheron, the great bee-master of Germany. This had been successfully worked at Sibertswood, and was used for some time at Hartlip, but finally abandoned for the more simple and easily workable hives that came into general use at this time; amongst which was one of Mr. Scott's own arrangement called the 'Hartlip Hive,' and which was used in some apiaries, but has now yielded to more simple forms.

The Hartlip hive was made by the Messrs. Green, of Rainham, Kent, then ignorant of bees, but now advanced apiarists, hive-makers, bee-masters, and experts; so kindly did they take to the art with very little instruction.

But it is time that some notice was taken of Mr. Scott's connexion with the British Bee-keepers' Association; this dates from the time of its first establishment by Mr. C. N. Abbott, in 1874, who had on all occasions his warmest support. In its days of infancy, when it was glad to receive the patronage even of a country vicar, Mr. Scott figured in its annual report as a Vice-president. He constantly attended and exhibited at its annual exhibitions at the Crystal and Alexandra Palaces. He was intimate with most of the prominent members; and on one occasion, when the health of the then efficient secretary, Mr. J. Hunter, began to fail, Mr. Scott was solicited by him to relieve him of the duties of his office, which, however, Mr. Scott did not either feel inclined or competent to undertake. For some few years after this he was called upon to act as one of the Judges at the Annual Exhibition at the Horticultural Gardens; and for the last three years has been elected, by the subscribers, to fill the honorable office of Committee-man. This he may be said to have been intimately connected with the B. B. K. A. from its very formation, and through its occasional struggles, almost for existence, up to its present flourishing condition, when, under the happy guidance and energetic exertions of the Rev. H. R. Prid, it has spread itself by branch associations throughout the length and breadth of the kingdom.

And here too, last of all, may be mentioned the success of Mr. Scott's efforts in forming an Association of the B. B. K. A. in his native county, Kent, or rather in the Eastern portion of it, for the Western division was first in the field. A bee fraternity, originating in a country parish, and called the Cray Valley District Branch of B. B. K. A., formed in the year 1878, gradually extended itself over the whole district, being called the West Kent B. B. K. A., by which name it was known until October 1881, when a meeting was called by Mr. Scott at the Cathedral library in Canterbury (the use of which had been kindly granted by Dr. Payne-Smith, the dean), which resulted in the formation of a Bee-keepers' Association for the Eastern division of the county. Mr. Scott was ably supported on this occasion by Dr. Parry, Bishop of Dover, Archdeacon Harrison, and several county gentlemen; and no time was lost in uniting forces with the bee-keeping brethren in the Western division; so that, as was well observed by the excellent secretary, Mr. Garratt, in the first annual report, 'what was at first the Cray Valley, and then the West

Kent Bee-keepers' Association, now assumed the full dignity of the Kent B. B. K. A.:' for this, partly Mr. Scott's own offspring, he continues to feel a parental regard, and has acted to the present time as local secretary for the Eastern division.

Mr. Scott looks forward to an early retirement from all offices connected with bee associations, which involve absence from home and parish duties, as well as some amount of correspondence; but he earnestly trusts that, so long as life is spared to him, he may be able, with a little assistance, to attend to the requirements of his home apiary, consisting of twenty stocks, in framed hives of various fashions, and to lend a helping hand to his poorer neighbours by instructing them in 'the better way' of managing their bees.

We trust that the reverend gentleman may be spared for many years in the performance of the duties of his high vocation, and that he may have much pleasure in looking back on the course of an active and useful life.

## AMONGST THE SWISS BEE-KEEPERS.

No. VIII.

After seeing what there was to see in the apiary, M. Jeker took us for a walk in the neighbourhood, and showed us all the sights. We entered several homesteads, and were much interested in the way the people manage here. The buildings are very pretty, and the dwelling-rooms, stables, cow-stalls, granaries, and hay-lofts, are all under one roof. There being no chimneys the smoke has to find an exit the best way it can by door or roof, and the inside of these buildings, which are of wood, are perfectly black, and like polished ebony. A walk in the forest disclosed a large number of bee-flowers, and the pastures were full of dandelions, from which a large quantity of honey is obtained. Our attention was called to an erratic block of granite, of large dimensions; and leaving the forest we inspected the cheese-making establishment of the place. Here we saw a cheese made from the milk of 400 cows, and it was one of the noted Emmenthal cheeses of huge size. We were amused with what ease the man turned these cheeses, weighing 200 lbs. and over each, his strong sinewy arms looking strong enough for any weight. By the way, we looked at several stands of bees, but these were kept principally in the old style, on shelves against the houses, being sheltered by the wide projecting gables of the roofs.

On our return we had supper, and more bee-talk, after which several songs of the country were sung by some of the company, and we retired well pleased with our first day's excursion. The next morning, at five o'clock, the church-bell roused up the whole village for the day's work. We indulged in bed for an hour longer, and then got up, but found M. Jeker gone to the church for morning service. On his return bee-talk was resumed, and another inspection of the apiary was made, as well as the valuable library of the Swiss Bee-keepers' Association. This was kept in M. Jeker's study, from which emanate all those clever articles which appear in the *Schweizerische Bienen Zeitung*, of which he is the able editor. On all sides were signs of literary work: here a heap of letters, there books of reference, and everywhere the same neatness and order that was observable in the apiary. Besides editing the *Journal*, M. Jeker has the additional work of President of the Verein Schweizer Bienefreunde. I have already mentioned that M. Jeker every year gives courses of lectures for the Society during the summer months. These courses are attended by a large number of students, and at the end examinations are held.

At some other time I shall have occasion to allude to these lectures when I am speaking on the state of bee-culture in Switzerland: suffice it to say at present, that it is a plan from which much good has resulted, and that it could be profitably adopted by us, sup-



plementing our examinations for certificates as experts which are held annually. After tasting specimens of honey from dandelions, also honeydew from the pines, we left this charming parsonage and its hospitable occupiers, regretting we had not been able to devote more time than we had, and taking away with us many new notions on the system of bee-keeping in this part of Switzerland. M. Jeker accompanied us to Zurich, which we reached in about three hours. Here we for a time separated, M. Jeker and M. Bertrand going to their duties as judges, and M. de Layens and I as inquisitive visitors to the bee department of the Exhibition. This I have already fully described, so will not weary my readers with a repetition. I can just fancy some saying, 'Have you not yet done with the Swiss bee-keepers?' Wait patiently, I have not much more to say at present, but I should not be giving a faithful description without mentioning two more apiaries we visited, although the description will be very brief.

Before leaving Zurich we conceived the idea of paying a visit to M. Kramer at Fluntern, so we made our way towards his residence. There we found he had not much to show us, as he had only just moved into a new residence and had not yet removed his bees; but he took us to see the bees of a friend of his, a M. Weber, who had twenty-five colonies in a pavilion. My surprise at seeing grape-vines trained over this pavilion can be imagined; and I was wishing those who had written about bees destroying grapes could have been with us. Here hung ripe grapes in bunches all over the pavilion close to the entrances of the hives, and the bees flying in and out in large numbers, yet not a single grape was injured; and M. Weber told us he had never known his bees to injure the grapes. Those who believe the contrary should go and see for themselves. In this pavilion there were five down to the level of the floor. On a king M. Weber if he did not find it inconvenient to manipulate his bees so low, he showed us a trap-door in the floor, by lifting which the operator could descend to another floor on a convenient level for manipulating.

Time was getting short, so we had to leave these gentlemen, return to Zurich, and then we started by train to Lucerne, on our way to see M. J. E. Siegwart at Altorf. Something might be said of what we saw and did by the way; but I shall not have time to describe how we stopped at the Cygne at Lucerne to taste the pure honey we supposed we should get there, and how we were only served with an imitation emanating from a large manufactory at Rapperschwil; or of the excursion by steamer to Altorf on one of the most picturesque lakes in Switzerland; or of William Tell's Chapel we passed, built on the spot where tradition says that this national hero landed when he sprang out of Gessler's boat a myth which has of late years been shown to have no foundation, and which has divested the Lake of Lucerne of much of the romance connected with the history of independence in Switzerland, or of the many other points of interest on the route; but will proceed to say something of what we saw at the apiary at Altorf.

A short conversation with M. Siegwart was sufficient to show that he was a scientific bee-keeper; and being an engineer by profession, he has brought his mathematical talent to bear upon apiculture. He has written several articles entitled *Les Mathématiques au service de l'Apiculture*, on the best form to give to a hive, and treating the subject in a masterly and exhaustive style. There are others also on the origin of the colour in honey; and although one cannot entirely agree in all his conclusions, the articles display an amount of argumentative spirit not frequently met with. In the garden we found a pavilion stocked with forty-five colonies, and about sixty hives in all, well filled with bees. There was one hive, 3 ft. by 18 ins. by 9 ins., once filled but now empty, on a spring balance, which had served its

purpose in demonstrating that hives are rarely too big to be filled by bees. After seeing them, we were shown into a room where comb-foundation was made, and saw a new Dunham machine operated upon. There were sheets of foundation of all sizes, and M. Siegwart told us he was obliged to keep a large variety, as the number of different-sized frames used was Legion. What a pity that our Swiss friends cannot simplify matters by adopting a uniform-sized frame, the same as we have done; it would work as satisfactorily with them, I have no doubt. We then were introduced into a room where the honey and wax were kept. Here were large cans filled with honey, but all of one colour, and that rather dark. M. Siegwart does not believe in separating the different harvests, but prefers to mix them altogether. He told us that the neighbourhood was a good one for honey, and there were several large bee-keepers about. After being hospitably entertained, we had a look round the town and returned to Lucerne, having enjoyed ourselves very much.

The next day we left Lucerne, and by way of Berne returned to Lausanne, where M. Bertrand and M. de Layens and I parted, the two former to go to Nyon and I to Montreux, agreeing that we had passed an agreeable and profitable ten days; and I shall always have a pleasant recollection of the friendly feeling and kind hospitality shown to us by all the Swiss bee-keepers. — THOS. WM. COVAX.

## RUDIMENTS OF BEE-KEEPING.

### THE HIVE AND ITS CONTENTS.

(Continued from p. 59.)

The egg of the worker-bee hatches on the fourth day after it is laid, the germ it contains meanwhile finding within it the nourishment it requires. The grub thus hatched now depends for food on a store provided ready for its use by the workers. On the ninth day after the egg is laid the cell is sealed over, and the grub spins within it its cocoon. Finally, after gradual change, it eats its way out of the cell on the twenty-second day, transformed into a perfect bee, and soon joins the rest of the colony in promoting the prosperity of the hive.

The brood in its various stages requires a high temperature to keep it alive, and soon dies if this temperature becomes insufficient from any cause. The greatest care is consequently needed to prevent the escape of heat by carefully surrounding the brood-chamber with packing. It can easily be seen what an enormous advantage a well-stocked hive has in this respect over a weak one. The brood may likewise easily be injured and displaced by rough, care-less handling, or the improper use of the honey-extractor. These are dangers which a beginner especially has to be on his guard against. Chilled, and what may finally become foul brood, will certainly ensue, and the colony will also lose many young bees, should these dangers not be kept in view. Great caution is necessary, therefore, in gaining the experience needed to enable you to judge when and how to handle your brood combs.

The egg of the queen-bee when laid is exactly the same as that of the worker. She has, however, specially prepared food subsequently provided for her, and she is reared in a specially prepared cell, placed in a hanging position in the hive with its mouth downwards. From this cell, unless previously destroyed, the queen issues on the sixteenth day after the laying of the egg, and if all is well, she will commence laying within a week or ten days afterwards.

The egg of the drone differs from the worker and queen egg entirely, and under no circumstance does it develop into anything but a drone. The cell in which it is reared is of larger size than the worker's; and, since it is undesirable and unprofitable to have a larger number of

drones in your apiary than are necessary, you must in every way possible discourage the making of drone-comb. In frame-hives this may in great measure be effected by filling the entire frame with worker comb-foundation. The drone takes a longer time than either the worker or queen to come to maturity, and does not leave its cell until the twenty-fifth day after being laid. It leads an idle life, and does little good in the hive excepting to increase its temperature. Our hives, however, would not prosper without any drones. Their presence in our apiary is essential. When the honey season begins to fail, all drones are got rid of from the hives, and they are mercilessly drawn forth and left to die.

No mention has yet been made of the formation of what may be termed the furniture of the hive—the combs. The wax of which they are formed is secreted in the body of the bee, and its formation requires a large consumption of honey. Modern bee-keepers supply this wax in the shape of comb-foundation, and consequently save their bees much work, and themselves much loss of honey. When the bee is left to make its own wax, the little flakes are gradually piled up and moulded into the honey comb. A temperature is required high enough to make the wax soft and workable, and a low temperature much hinder, or perhaps entirely prevents, its formation. Once made, the combs provide the nursery for succeeding generations of bees. In them are stored the honey and pollen, and on them the bees cluster. When empty they form warm protections from draught and assist largely in confining the heat in cold weather, to the spot where the cluster rests. With a view too of keeping the hive warm, the bees use a kind of sticky substance gathered from the trees named "propolis." This they place into any cracks or other places where escape of heat is possible.—F. S. SOLATER.

(To be continued.)

## ASSOCIATIONS.

### BRITISH BEE-KEEPERS' ASSOCIATION.

The Annual Meeting of this Institution was held on Wednesday, February 20th, 1884, at 4 p.m., in the Board Room of the Royal Society for the Prevention of Cruelty to Animals, 105 Jermyan Street, St. James's, which was filled to overflowing with the Committee and Members of the Association as well as representatives from the different county branches. Several ladies interested in the proceedings were present among the audience.

The Baroness Burdett-Coutts, President, occupied the chair, and commenced the proceedings by requesting Mr. Huckle to read the minutes of the previous meeting.

After these had been read to the Meeting and signed, her ladyship rose to propose the first resolution, namely, 'That the Report and Balance Sheet issued for the year 1883 be received and adopted, with a vote of thanks to Mr. Kitchner, the Auditor.' In the course of a short address, she said that the past year had been one of some anxiety to the Association, which had happily, however, struggled through its financial difficulties, and at the present moment all the clouds which hung heavily over it had been removed. They had been blamed by some for running considerably into debt, but she was of opinion that the Committee were justified in the course they had taken. The money had been spent legitimately in carrying out the objects of the Association—in the formation of County Associations, which were most useful in diffusing throughout the country a knowledge of bee-keeping, and all that is connected therewith. She trusted the Local Branches would not be unmindful of this, but make so far as they could some acknowledgment of the help rendered to them. Of course the

Committee were well aware of the limited nature of the resources of Provincial Associations, all of which it might be said in most cases were necessary for the development of their own individual undertakings. Her ladyship concluded by expressing a hope that the bees would have a fine summer and prosperous harvest, which she also trusted would be the case for the benefit of humanity at large.

The resolution was carried *nem. con.*

The Rev. F. G. Jenyns proposed a vote of thanks to the Retiring Officers and Committee. He considered this vote was richly deserved as anyone knew who had witnessed, as he had, the untiring energy, the hard work, and voluntary sacrifice of time, made by the Committee and officers of the Institution. Their efforts were directed solely and unselfishly to the welfare of the artisan and labouring classes in the country; and he was sure it must be exceedingly gratifying to them to know the good results which had attended their labours. Speaking of Mr. Peel, the retiring Secretary, he felt bound to say that that gentleman had accomplished more for the Association and for the cause of bee-keeping than ten ordinary men could be expected to do. The President had also rendered them invaluable assistance. As they all knew she stood pre-eminent among those who gave their time, money, and influence to the furtherance of every good work.

Mr. W. H. Dünman seconded the motion, which was carried unanimously.

The Rev. E. Bartrum returned thanks on the part of the Committee, which, he was happy to say, had worked most harmoniously, thus affording a contrast to their proceedings before Mr. Peel's time. He quite agreed with what had fallen from Mr. Jenyns respecting their late Secretary; and, on behalf of the Committee, he begged to move the following resolution, so that their appreciation of him might be placed on record:—'That this Association desires to express its best and most grateful thanks to the Rev. H. R. Peel for the invaluable services he has rendered to the Association and to bee-culture during the period he has acted as Hon. Secretary, and earnestly trusts that he may be spared many years to see the work in which he has taken so deep an interest making progress in every way.' Mr. Peel, he might say without any suspicion of flattery, had always tempered his zeal with discretion; he had known how to carry the iron hand under the silken glove, to combine the *suaviter in modo* with the *fortiter in re*. He bore an illustrious name, the name of one who had been a benefactor to the human race by the introduction of cheap food at a time when a large mass of our fellow-countrymen were starving. Some of his friends were perhaps old enough to remember an important political party named 'Peelites.' This party no longer existed, but he thought the name, if used in future, could only be applied to advanced bee-keepers. In the annals of bee-culture the name of Mr. Peel will be written in numbers that cannot be erased, in a monument more enduring than brass.

The Rev. G. Raynor, as a personal friend of Mr. Peel, cordially agreed with the last speaker in his eulogium of Mr. Peel. He was of opinion that the actual existence of their Association at the present time was due to that gentleman entirely, under whose *regime* it had emerged from obscurity, and become to be recognised as one of the public institutions of the country.

The Baroness Burdett-Coutts would not dwell upon what she should like to say of Mr. Peel, because of his presence amongst them, and also because she should considerably prolong the meeting in doing so. She could not, however, refrain from saying how deeply indebted she had been to that gentleman for his assistance during the time of her Presidency of the Association. He had always been anxious to take more than his share of responsibility. She thought it no exaggeration to say that this

country was largely indebted to Mr. Peel. The country, which is never ungrateful to those who serve it well and truly, will recognise, and does recognise, this. She could bear witness to the very great benefit which his illustrious namesake, whom she had had the honour of calling a friend, had conferred on the poor of his country. Their esteemed coadjutor by her side had been following in the footsteps of his relative, for his exertions had been unremitting in the direction of obtaining pure and cheap honey for the working classes. She was quite sure that the cottagers of England would heartily join in seconding this motion.

The resolution was carried by acclamation.

The Rev. Herbert R. Peel said he was not insensible of their kindness; but he must say that this resolution was a departure from the harmonious relationship which existed among the committee. He must quarrel with the mover, who had travelled out of the record by proposing a motion not on the agenda (laughter). He had not retired from the position of secretary from any diminution of interest in their proceedings, not from any fear of hard work, and certainly not owing to the ill success which had attended their two shows at Bridgewater and Knightsbridge. The latter circumstance, in fact, had almost made him reconsider his decision. The truth was, that so long as he lived in Hertfordshire, where he was only a few minutes' walk from the Assistant-Secretary, Mr. Huckle, the business of the Association could be transacted without making an unreasonable demand on his time. He now lived further from London, namely, in Buckinghamshire, and the consequence was, that he could not be daily in communication with Mr. Huckle. On an average from ten to twelve letters were received by him in connexion with the business of the Institution. He had to answer these letters, acknowledge the receipt of subscriptions, and pass over everything on afterwards to Mr. Huckle. It appeared to him that this meant a waste of labour and money. They would be surprised perhaps to hear that the outlay in stamps, &c., by this system was about 10*l.* per annum. Well, he thought, if this money must be expended, it had better be paid to the Institution than be employed in doing work twice over. As long as the Association was small he could accomplish the work very well; but he had other duties in life, and he felt that the operations of the Association had grown to such an extent that the Society might as well be called a national one, and the case was different, of course; it might be thought that an Honorary Secretary would be better than a paid Secretary. All he could say was, if any gentleman would undertake the duties, which really occupied all one person's time, he should be very glad. Probably there would be no response to this, and he therefore suggested that Mr. Huckle should undertake the duties of Secretary. He had a thorough knowledge of the affairs of the Association and was thoroughly acquainted with everything connected with the bee-keeping interest. When he (Mr. Peel) left Herts, he lost that knowledge and that power, and yet he had the responsibility. In conclusion he thanked the Committee for all the confidence they had reposed in him, and for the support and assistance they had always given him. If they chose to do him the honour of electing him on the committee he should always be happy to render any services to the Association which lay in his power to perform.

The Hon. and Rev. H. Bligh proposed, and the Rev. G. Raynor seconded a vote of thanks to the Council for the Prevention of Cruelty to Animals for the gratuitous use of their Board Room for Committee and other meetings; to which the Baronesse Burdett-Connis responded.

The Rev. F. T. Scott proposed the election of the President, Vice-President, Treasurer, Librarian, Auditor, and Secretary for the year 1884, in accordance with Rule 8. He quite endorsed all that had been said respecting the immense advantage which the Institution had

derived from the President and Mr. Peel. He thought they were fortunate in obtaining the services of Mr. Huckle, whose business-like habits, calm temper, and devotion to his work, had made him a favourite with them all.

Mr. Jesse Garratt wished, in seconding the resolution, to add his concurrence in all that had been said respecting Mr. Peel. With regard to the remarks concerning the duty of the County Associations toward the central body, he could only say that the children were not unmindful of the debt they owed, and in the event of any definite suggestion being formulated the proposal would certainly meet with every consideration from the branches. Mr. Peel had used the word 'national' in speaking of the Association. He thought that in future the keeping of bees should be placed before the cottager as a national pursuit. The past had shown clearly that this country is capable of great things in the way of honey-producing. He thought the success of a member of his own Association extending over three years varying in their character proved that the production of honey was becoming a nice and certain undertaking. In 1881 the individual to whom he alluded produced 80 lbs. of honey per hive; the following year, which was a very bad year, 40 lbs.; and last year 70 lbs.

The Secretary read the report of the election of the Committee for 1884, the following gentlemen having been returned: viz. Mr. T. W. Cowan, Rev. H. R. Peel, Rev. H. Bligh, Rev. G. Raynor, Rev. F. Bartrum, Mr. J. M. Hucker, Mr. Jones, Mr. D. Stewart, and the Rev. F. T. Scott. The Rev. H. R. Peel moved a vote of thanks to Mr. Willard for his services in acting as secretary. Carried unanimously.

Mr. Stewart made a few observations respecting the proposal of the Agenda Committee for formation of a Metropolitan depot for the sale of honey, and suggested a museum, and strongly advocated the establishment of such a building, which he believed would soon become self-supporting.

Mr. Drakwater proposed that three members of the Committee of the B. B. K. A. be appointed to report in full detail upon the formation of a Metropolitan depot for the sale of honey, and suggested a museum, such report and scheme to be published in the issue of the *B. B. J.* on proceeding to the quarterly meeting to be held in April next, such report to be taken into consideration at the quarterly meeting. This proposition involved the taking of a lease for a central position in London, the ground to be the site of a shop, which would sell pure honey on commission; the upstairs rooms would consist of a landing and place of rendezvous for bees, open air, and rooms for a man and his wife, who would live on the premises, and perhaps other rooms which might be let out to lodgers. He proposed to meet this problem by a charge of 1*l.* per pound, or thereabouts, to be made on our honey sold at the depot by a yearly subscription from all bee-keepers who availed themselves of the advantages of the reading-room as a place of meeting, &c., by a charge to traders who sold to exhibit their hives and other contrivances in the museum, and by the rent of lodgers occupying the upstairs rooms. He thought they might calculate that 50,000 lbs. of honey would be sold during the year at the depot. He quite acknowledged that his proposal seemed a fearful idea, but he thought the subject should be ventilated in the *Bee Journal*.

Mr. J. P. Jackson characterised the scheme as exceedingly crude. He did not think the establishment would be self-supporting, and felt sure that if any reasonable profit could be made by the sale of honey, some out of the many enterprising persons in this great city, looking out for an opening for capital, would have carried out the proposal long ago. He begged the Committee, who were only in recovering from their recent financial difficulties, not to embark in so hazardous an

enterprise. He supposed that honey would be offered at the *dépôt* at not more than 1s. per pound. That would mean, taking into account the commission, the charge for carriage, chance of breakage, &c., that the producer must send his honey to London at 6d. per pound, a price which he can easily get in the country, with no trouble or risk. He moved, as an amendment, that the consideration of the matter be deferred for twelve months.

Mr. W. H. Dunman seconded the amendment.

Mr. Stewart seconded the original motion.

The Rev. E. Bartrum opposed the motion. Although in theory he thought the suggestion an excellent one, the difficulties in carrying it out were too numerous to justify him in supporting the proposal. He had no faith in the belief that tangible profit could be made by the sale of honey.

Mr. Hinton opposed the motion, saying that supposing the large amount of 50,000 lbs. of honey were sold by the *dépôt* at 1d. per pound commission, only 200l. would be realised thereby. There could not be a doubt that the working expenses of such an establishment as that proposed by Mr. Drinkwater would be at least 400l. per annum. It appeared to him also that the proposed exhibition of new inventions relating to bee-keeping at the museum would militate against the success of their annual show.

Mr. Baldwin opposed the motion. He thought there would be great difficulty in getting the honey for sale at the *dépôt*. He had experienced this during his management of honey sales, although he had never found any lack of buyers. He thought they must not rely on getting any great income from the sale of honey.

Mr. Glennie, the Rev. F. S. Selater, and the Rev. F. G. Jenyns opposed the motion.

Mr. F. Lyon stated that in June of the year 1882 his attention was called to a letter in the *Grazer* about Swiss table honey. On trying a sample of this he found it to be grossly adulterated, and to consist only of glucose. He was informed that the honey derived from the bees of Switzerland was of so intensely acid a nature as to be injurious to health. He had, however, been unable to procure any specimens of the flowers from which the bees had extracted this honey. He could not support the motion. He did not think the proposed *dépôt* would be a success. He believed that the sale of honey in London could be advanced considerably by a system of collectors and travellers, which of course would not involve the expense incurred by the establishment of a *dépôt*.

Mr. Garratt quite agreed with previous speakers in thinking that the *dépôt* would not be a success. There was no doubt that cottagers would seek a market for their honey near home first, and if that failed, perhaps would send it up to the *dépôt*. Of course, under these circumstances, the sales at the *dépôt* would be too precarious to be reliable.

The Rev. J. L. Seager opposed the motion.

The amendment was then put to the meeting, and carried with only five dissentients, the original motion being thereby negatived.

The Rev. Herbert R. Peel (in the absence of Mr. Cowan) moved, 'That some medical man be requested to read a paper at the next Quarterly Meeting of the British Bee-keepers' Association on the subject of honey as used in medical treatment; and also that Mr. Otto Hehner be invited to accept the post of Honorary Analyst to the Association.' He said the President had suggested to him that she thought it would be very much to the benefit and the credit of the Association if it could bring before the notice of medical men the advantage of pure honey as an article which they might use in the treatment of their patients; and he had accordingly formulated the resolution just read to them.

The Rev. E. Bartrum seconded the resolution. He

recommended that the Association should prosecute in cases where spurious honey was sold as the genuine article.

After a desultory conversation, in which Mr. Jackson, Mr. Hinton, and other members joined, the resolution was unanimously passed, the noble President promising to ask an eminent medical gentleman of her acquaintance to read the paper referred to.

Mr. Stewart moved, (1) 'That the Committee be enlarged by adding six names, making fifteen in all.' The Rev. H. R. Peel seconded this. (2) 'That the Rev. H. R. Peel, the Rev. G. Raynor, Mr. T. W. Cowan, the President and Treasurer, be appointed as trustees of the funds and property of the Association.' Seconded by Mr. Dunman. (3) 'That the increase of six members of the Committee, in accordance with the above resolution, be filled up from the unsuccessful candidates, according to the priority of votes obtained at the recent election; viz. Capt. C. D. Campbell, the Rev. F. S. Selater, Rev. F. G. Jenyns, Mr. John Bower, Captain Bush, and Mr. W. Martin.'

A lengthy discussion followed, in which the noble President, the Rev. H. R. Peel, Mr. Jackson, Mr. Glennie, and several others took part, which ended in Mr. W. H. Dunman seconding the motion.

Mr. Huckle explained that the property of the Association for which the trustees would become responsible consisted of bee tents, books, literature, diagrams, &c., worth perhaps about 200l.

The resolution was carried *utem con*.

Mr. W. H. Dunman wished, before the meeting separated, to bring before the members the desirability, which he thought they would all concur in, of presenting a testimonial to Mr. Peel for his valued and ungrudging services to their cause during the several years of his secretaryship.

The noble President and Mr. Jackson heartily sympathised with the movement, and hoped a Committee would soon be started to give effect to such proposition.

The Rev. H. R. Peel would much prefer that no testimonial should be made to himself. If the project took the form of something serviceable to the Association he should not object.

A vote of thanks to the noble President for kindly occupying the chair on the occasion was unanimously carried, which her Ladyship appropriately acknowledged, and the proceedings terminated.

The following are the more prominent features of the Report:—

In presenting their Report for the year 1883, the Committee are pleased to announce that 95 new members have joined the Association, including His Grace the Duke of Buckingham and Chandos, the Earl of Harewood, &c.: 47 have withdrawn; 2 have died; the present total being 400. The Committee regret that many members have withdrawn from the Association on the ground that they have become members of County Associations. As the minimum subscription to the Central Society is small, it is hoped that members will not withdraw their subscriptions upon this plea.

During the past year the Committee have endeavoured to carry out the aims and objects of the Association, by the formation of County Bee-keepers' Associations, and in assisting several of those established in previous years by sending lecturers and experts for the purpose of giving instruction in the art of bee-keeping. Such assistance has been given during the past year to the counties of Carmarthen and Brecon, in South Wales; Northamptonshire, Buckinghamshire, Somersetshire, Bedfordshire, Staffordshire, and Huntingdonshire; at a cost of nearly 50l. Some of the County Associations have an appointed expert who visits, at stated periods, the members and cottagers residing within the county, for the purpose of giving them instruction in the manage-

ment of their bees. Your Committee consider that the appointment of one expert at least to each County Association for periodical visitation is a matter of the greatest importance, and they regret very much that the funds hitherto at their disposal have not enabled them to make grants for this purpose.

In accordance with the rules of affiliation, grants of medals and certificates have been made, and awarded at the following County Shows:—Bucks, Hants, Cornwall, Devonshire, Dorsetshire, Breconshire, Herefordshire, Huntingdonshire, Kent, Lincolnshire, Leicestershire, Norfolk, Northamptonshire, Oxfordshire, Shropshire, Staffordshire, Suffolk, Surrey, Warwickshire, Wiltshire.

During the past year, the Association's Bee Tents have been in great demand, and extensively used by the County Associations. Upon reference to the balance-sheet, it will be found that although thirty-four shows have been visited, the profit of *£l. 14s. 5d.* only has been derived from the Bee Tents. This sum has not proved sufficient to cover the cost of repairs and other expenses attendant upon the transit of the tents from place to place. It has, therefore, been resolved that in future *1/2* be charged to County Affiliated Societies for the use of the Bee Tents at all shows other than those at which the Bee Tent is allowed free, in accordance with the rules of affiliation.

The second examination of expert-despairs of gaining Certificate of Competence in Modern Bee-keeping was held at Knightsbridge on Saturday, July 7th. The examination was conducted by Mr. T. W. Cowan, the Hon. and Rev. H. Bligh, the Rev. E. Bartrum, and the Rev. G. Rayner. The following certificates were awarded: 1st class, Rev. W. E. Burkitt; 2nd class, C. N. White, and H. Cobb; 3rd class, J. R. W. Hole, H. E. Roberts, J. Davies, and A. W. Rollins.

Three meetings have been held during the year at which papers have been read, viz.: (1.) On January 21, by the Rev. W. E. Burkitt, subject: 'The best way of Instructing Cottagers in the Art of Bee-keeping.' (2.) On April 25, by the Rev. H. R. Ford, subject: 'Who is the *bona fide* Cottager?' (3.) On October 17, by Otto Hehner, Esq., F.R.S., F.L.C., subject: 'The Chemistry of the Hive.' Copies of these papers have been sent to each member of the Association.

The demand for the several books and pamphlets published by the Association continues to increase. The fourth edition of *Modern Bee-keeping* was published in July. A considerable portion of this edition has already been disposed of. In accordance with the resolution passed at the last Annual General Meeting, a penny guide to the most Profitable Management of Bees in Straw Skeps has been published for the special use of cottagers. It may be obtained upon application to the Secretary, Mr. J. Huckle, King's Langley, Herts.

*The Library.* During the past year several new works have been added to the library, and the books have been kept in active circulation.

The Economic Aptitudes Competition commenced on May 20th, 1882, and terminated on August 31st, 1883. Seventeen candidates entered for competition; two withdrew previous to the commencement, and eight resigned during the progress of the competition, seven only competing to the close. Your Committee are of opinion that this competition has been most beneficial to the cause of the Association, by demonstrating that, with a fair knowledge of the art, bee-keeping is a most profitable pursuit.

*Honey Market.* The important question of arranging for the sale of honey produced by members of the Association has received much consideration during the past year, and a Sub-Committee was appointed to make inquiries.

*Reading-room, Museum, and Hive Depot.* In connexion with the project of a honey depot, the larger

question of a reading-room and museum naturally arises. Such an institution would not only help to advance the knowledge of the subject we all have at heart, but would tend, perhaps, more than anything else, to raise the character of the Association. Many scientific persons are working in our cause; but a museum and reading-room would bring them together into a scientific union, where they would compare the work that is being done, and spread it among a larger circle of workers. It can hardly be doubted that such an institution, particularly if combined with a depot for the exhibition of bee furniture, would meet with extensive support from bee-keepers, and it is hoped that a fund may be raised to enable the Committee to found it. Contributions have been already promised towards this object, both of money and exhibits, and the Committee can favourably recommend it to their constituents for support.

*Annual Show.*—The year 1883 has been an eventful one in the history of the Association. Since its formation in 1874, its Annual Metropolitan Exhibitions have been held under the auspices of other Societies, which have rendered the Association very material assistance. From 1878 to 1882 inclusive, the Annual Show was held in the Gardens of the Royal Horticultural Society at South Kensington. During the year 1883 the whole of the available space in the Gardens was occupied by the International Fisheries Exhibition. His Grace the Duke of Wellington kindly placed his Riding School at Knightsbridge at the disposal of the Committee, and arrangements were made for holding the Annual Show during the first week in July. It was hoped that by holding the Exhibition during the height of the London season, the Association would have realised a considerable profit. The Exhibition (through the generosity of visitors) resulted in a loss of upwards of 100*l.* The Annual Show of 1883 was the largest and best exhibition held by the Association since its formation, and, from a bee-keeping point of view, was most successful. The exhibition of honey was a grand one, especially in the cottager classes. One cottager realised nearly 18*l.* by the sale of honey, and upwards of 2*l.* in prize money was awarded to the same exhibitor. The total sales of goods and honey combined amounted to nearly 200*l.*

The Association also held an Exhibition of Bees, Hives, Honey, &c., at Bridgewater, at the time of the Bath and West of England Agricultural Show. This Exhibition resulted in the establishment of a County Bee-keepers' Association for Somersetshire, and stimulated many of the residents in the West of England to take an interest in the promotion of the modern system of bee-keeping. Owing to the generosity of visitors, the Association suffered a great loss by this Exhibition.

The Association was presented at the Annual Show of the Royal Agricultural Society, held at York, on July 19, and the four following days. The best partment of this Show was thronged with visitors on each day, and much good was accomplished. Arrangements have been made for holding a similar exhibition at Sheepshury on July 14-17, 1884, under the same auspices.

To meet the deficiency caused by the Knightsbridge and Bridgewater Shows, the President and Committee advanced the sum of 150*l.*, and forthwith made an appeal to the members for donations towards defraying the debt. This appeal resulted in twenty-two members becoming life members, and donations amounting to 45*l. 13s. 6d.* have also been received, making a total of 195*l. 13s. 6d.* The sums so received have enabled the Committee to free the Association from debt; but increased support is still required to carry on the progressive work of the Association.

The following members have also increased their subscriptions for 1884, viz.: Rev. C. G. Anderson, J. C. Arber, Captain Bush, R.N., W. Carr, Rev. A. Corbet, W. H. Dummer, J. Garratt, Miss Gayton, G. Henderson,

F. C. Hodgson, W. Hunt, H. Jonas, J. Kingsmill, F. Lyon, C. J. Myers, Rev. N. Ogilvy, Miss E. Preston, A. G. Radcliffe, Rev. F. S. Selator, S. Simmins, Rev. T. Sissons, J. Stevens, G. Stothard, R. Thorpe, C. Tite, C. Tucker, C. F. Williams, and F. Zehetmayer.

From the Auditor's Report, it appeared that above 1100*l.* had been received and expended during the year.

#### COMMITTEE MEETINGS.

Permission has been granted for the Committee to meet at an earlier hour. The next meeting will be held on Wednesday, March the 6th; Finance Committee to meet at three o'clock; the General Committee at 3.15.

#### HERTFORDSHIRE BEE-KEEPERS' ASSOCIATION.

The fifth annual general meeting of the members of the Hertfordshire Bee-keepers' Association was held at the Free Schools, Hitchin, on Tuesday February 19. Mr. H. G. S. Hughes presided, and amongst those present were the Rev. F. G. Jenyns, the Rev. J. L. Seager (honorary secretary), Messrs C. Barsley, T. B. Blow, Brewster, E. Jackson, T. B. Letchmore, J. Martin, L. Moulds, F. Moulds, H. E. Roberts, A. Ramsden, F. Shillitoe, M. Wren, J. Huckle (assistant secretary), Mrs. S. Lucas, Mrs. and Miss Homan, Miss Sewell, &c.

The Chairman, in moving the adoption of the report and balance-sheet, said he thought he might fairly congratulate the Association on the condition of their finances. The income, as they saw, had amounted to 108*l.* 10*s.* 5*d.*, and the expenditure had been 102*l.* 15*s.* 3*d.*, which left a balance of 4*l.* 17*s.* 2*d.* in hand. This balance would have been greater but for the fact that a large deficiency had been incurred in connexion with the show in 1881, and that it had to be made good. He was glad to see that the report stated that this deficit had been paid, and that the Association was not owing anything. The report also stated that during the spring months lectures had been delivered in various parts of the county by gentlemen whose names were given, and he thought they would agree with him that their thanks were due to these gentlemen for what they had done. He thought also that their thanks were due to the Rev. F. G. Jenyns, the Rev. J. L. Seager, Mr. Sambell, and others, who had organised these lectures, and who had in this way given much practical advice on bee-keeping, and instructed cottagers and others in the best way to profit by this industry. As seen by the report that a cottager in Berkshire had received from sales of honey and prizes awarded to him the sum of 25*l.* last year, and also that a lady residing at Hadham, in this county, made as much as 60*l.* last year by her bees. This lady began with an expenditure of 1*l.* 12*s.* 6*d.* in 1876, and in eight years she had cleared 156*l.* 16*s.* 1*d.*, her present being of the value of 10*l.* 5*s.* 1*d.*. These were facts which he thought ought to have an effect with the cottagers of Hertfordshire.

Mr. H. E. Roberts seconded the motion, and it was carried unanimously.

The next business on the agenda paper was 'The rules of the Association to be revised, and resolutions to be moved by the Honorary Secretary,' and the Rev. J. L. Seager said he had some very important changes to suggest in the rules. The fourth rule now read: 'The Committee shall consist of not less than twelve members, six of whom shall be chosen from the eastern and six from the western side of the Midland Railway. The committee to appoint their own chairman for each meeting, and the chairman to have a casting vote.' He said that the Midland Railway was by no means a good division of the county, and if there was to be any division at all it should be the Great Northern. He therefore moved that the committee in future be chosen six from the eastern and six from the western sides of the county, and that three members form a quorum.

The motion was carried.

The Rev. J. L. Seager moved that the fifth rule be so altered that labourers should be admitted to membership on payment of one shilling a year, and further that the provision 'Subscribers of 10*s.* 6*d.* and upwards be alone eligible to serve on the committee' be struck out.

The motion was carried.

The Rev. F. G. Jenyns next moved the re-election of the Rev. J. L. Seager as Honorary Secretary. They knew that a secretary should be the life and soul of a society, and that it would prosper or decline according as he performed his duties in an active or dilatory manner. Their Association was prospering now, and they owed that fact to Mr. Seager's indefatigable working. They should be extremely unfortunate should anything occur to take him away from it, and he was sure he was only expressing their wish in asking him to continue in the office. Their thanks were especially due to him for his services on behalf of the Association.

The motion was carried unanimously.

The Rev. J. L. Seager, having expressed his intention to continue in office, moved the re-election of Mr. T. B. Blow as the expert of the Association, which was carried unanimously.

Mr. F. Shillitoe moved the re-election of the committee with the addition of Mr. Sambell's name.

Mr. E. Jackson seconded the motion, which was carried unanimously.

The Revs. F. G. Jenyns and Astley Roberts were appointed the representatives of the Association to attend the quarterly meetings of the British Bee-keepers' Association.

Arrangements were made for the spring visit of one or more experts, and it was also agreed that an autumn visit should be made if the funds of the Association permitted it.

A resolution was passed 'That two shows be held this year in different parts of the county, if possible in connexion with horticultural or other exhibitions: that at these shows only bronze medals be offered as prizes to subscribers of 5*s.* and upwards, and money prizes and hives, both straw and bar frame, to artisans and labourers.'

A cordial vote of thanks was given to the Chairman for presiding.

The drawing for the three prize hives then took place, with the following result: First prize, Major-General Miles, Sarrait Hall, Rickmansworth. Second prize, Mr. G. H. Wye, Potter's Bar. Third prize, Captain Long, Bramfield House.

#### SURREY BEE-KEEPERS' ASSOCIATION.

The Report for 1883 states that during the past year this Association has made steady progress, and that forty-three new Members have joined, making the total number 160, many of whom are cottagers; while its work in parts of the county where its operations were hitherto almost, if not quite, unknown must tend to increase its future usefulness. The Annual County Show was held in the grounds of the Royal Military College at Sandhurst, on the 5th and 6th of September, in connexion with the local Horticultural Society's Show. During the season the County Bee Tent has visited Farnham, East Molesey, Guildford, Albury, and Haslemere, and at these Shows prizes were given for honey, with the view of encouraging cottagers to use sectional supers, as being one of the most profitable forms in which honey can be offered for sale. A very successful Exhibition of bees, honey, and bee appliances, was also held in connexion with the Flower Show at Croydon, on the 19th of June. One of the British Bee-keepers' Association Bee tents was engaged at the Flower Show at Wimbledon, under the able supervision of the Local Secretary, G. Walker, Jun., Esq., who has also given several lectures in his district on matters connected with bee-keeping. The Cottagers' Expert, Mr. James Flon, of

Farncombe, has made various excursions in the district, gaining several new subscribers and starting some of them in adopting bar-frame hives. It is very gratifying to find that the payments made for the services of the Expert have nearly covered the whole of his cost, besides inducing several new Members to join, thus greatly advancing the objects of the Association. The Committee hope to make satisfactory arrangements with the Royal Counties' Agricultural Association, for holding an Exhibition of bees, hives, &c., at their intended Show in Shalford Park, near Guildford, which they trust may result in extending their field of operations. The Committee greatly regret the resignation of R. Daw, Esq., their Hon. Secretary, and wish to render him their best thanks for his past services. The Balance Sheet shows cash in hand 14*l.*, with no outstanding liabilities, and with property of the Association in stock, including Tent, apparatus, literature, &c., to value of 25*l.*

#### LINCOLNSHIRE AGRICULTURAL SOCIETY.

Allow me to state that this Society will hold its annual exhibition at Grantham on Wednesday, Thursday, and Friday, 23rd, 24th, and 25th of July; and I am pleased to add, for the information of both bee-keepers especially, that the Society again includes in its programme "Bee Department"; also that the Prize Schedule has passed muster, offering a sum amounting to twenty-six pounds odd in prizes for bees, honey, hives, &c., and the arrangements of the department to be, as hitherto, entrusted to members of the Lincolnshire B. K. A.

My special object in penning this intimation is just now is to impress upon managers of local bee-keepers' associations the great importance of attaching themselves to these large county agricultural societies, in view of the immense good which may thereby be accomplished. At their annual exhibitions opportunity is afforded such as can be found in no other way of working upon the feelings of thousands of the public, and of arousing their interest in behalf of our common cause. No words of mine are needed to commend to the notice of all the very important point gained by the British Association when they first got their feet into the Show Ground, "although it happened to be muddy" of the Royal Agricultural Society, which grand achievement, if I mistake not, was brought about by Mr. Peel, to whom a lasting debt of gratitude is due, as the success which was bound to follow is now being seen and felt throughout the country. We in Lincolnshire are indebted to Mr. Walter Martin, of Wainfleet, for the tact displayed in bringing the objects of the L. B. K. A. before the notice of the council of the Lincolnshire Agricultural Society, which resulted in their agreeing to adopt his suggestion; and it is satisfactory to me to know that this Society is really doing a mighty work for us; they provide annually a liberal prize schedule, three days' manipulation, and bear all and every expense, whilst we most cheerfully render the Society any assistance required. I will forward a schedule for your advertisement columns in due course. Bees doing well in this part. R. R. GORMERY, *Grantham*.

#### GLOUCESTERSHIRE BEE-KEEPERS' ASSOCIATION.

Regarding the reference to the above Association in the last issue of the *B. B. J.*, it is to be regretted that the Rev. Mr. Bartlett should have felt discouraged by his first attempt. Speaking for the bee-keepers in Cheltenham, I would remark that three o'clock, the hour fixed for the meeting, of course precludes our attending; and I think, both for railway communication, central position, and importance, Cheltenham would make a much better centre than Gloucester. For myself, I would be willing to take the secretaryship. I think

that a county so rich in bee-keepers and natural advantages requires but a little continued effort on the part of the Rev. Mr. Bartlett to make it a success.—W. D. SLADE, *The Ironside, Cheltenham*.

If any deduction is to be drawn from the correspondence that has appeared in our columns, it is that there is an earnest desire that the Bee-keepers' Association in Gloucestershire should be sustained, and that there are many in the county willing to work to bring about this result. It is very undesirable that the exertions made by the Rev. W. E. Bartlett to establish this Association should come to naught. We would advise that another meeting should be called in a town easy of access, at an opportune hour, and that due notice of this should be given to bee-keepers, and to the public generally. It is very possible that if the Central Association were appealed to, they would be pleased to send a deputation to the meeting. It is to be hoped that Gloucestershire, with a population of above half-a-million, an acreage of above 800,000, and many natural advantages, will enter the comity of County Associations.]

LECTURES ON BEES AND BEE-KEEPING. On Monday, Feb. 4 and Feb. 11, by special invitation, Mr. W. Crisp, F.R.S.E., delivered two most interesting lectures to large and influential audiences in the public lecture-hall, Great Aston. The Rev. R. M. Withington, M.A., in the chair. Mr. Crisp, in a few appropriate remarks alluding to the gradual growth of his audiences during the course of lectures, and the evident interest in the special lectures on bees, hoped by the aid of specially-prepared lantern slides to be able to instruct and amuse, so that to follow the pursuit of apiculture as a hobby only would be a means of keeping young people from spending their time at casinos and/or alehouses, and to divert their mind by the study of one of the most interesting insects. The slides being now shown on the screen by the aid of the oxyhydrogen light, the whole mysteries of the interior of the beehive were brought to view, the use of different bee appliances, views of different bar-frame hives, and the whole paraphernalia of modern bee-keeping, were graphically described. The lecture lasted above two hours. Many interesting questions were asked and satisfactorily answered, votes of thanks passed, &c. The second lecture showed an undiminished interest in the subject. The Rev. R. M. Withington, in his opening remarks, wished all his parishioners to keep bees as a means of improving their minds, and desired the lecturer to say something on the diseases of bees. Another set of forty slides were successively thrown on the screen, and appropriate remarks made thereon by the lecturer, who alluded to the important part bees played in the economy of nature, by the fertilization of fruit trees, and instanced many striking cases in point. Next came different kinds of bees and their characteristics, the lecturer favouring a first cross from Ligurian and black bees. The various wild bees were briefly touched upon as the appropriate slides appeared on the screen. Then came prominent bee-keepers, Messrs. Huber, Abbott, and Neighbour. Bee-farms followed by several American bee-keepers, and finally wound up with illustrations, (after a hard winter, of a straw-sheep looking dubiously at his beehive). The lecturer alluded in high terms to the organization of the British Bee-keepers' Association, and to the *Bee Journal* in particular. Many interesting questions were asked and replied to, and arrangements were made to deliver two lectures in Bill-slade. Votes of thanks to the chairman and lecturer brought to a close a most successful course of lectures, Mr. Crisp having doubled his audience each evening until the room was packed. The inquiries for bee-books, &c., have been most abundant since the the natives have decided to commence bee-culture upon the humane system.

## Correspondence.

\* \* All Correspondents forwarding Letters for insertion in the Journal, Reports of Associations, Shows, Meetings, Echoes from the Hives, Queries, &c., are requested to direct their communications to 'The Editor of the "British Bee Journal," c/o Messrs. Straungeways & Sons, Tower Street, Upper St. Martin's Lane, W.C.'

### OUR HONEY IMPORTS.

The value of honey imported into the United Kingdom during the month of January, 1884, amounted to 2064l. [From a private return sent by the Principal of the Statistical Department, Her Majesty's Customs, London to E. H. Bellairs, Wingfield, Christchurch.]

### OUR HONEY IMPORTS.

Through the courtesy of Mr. Selton, the Principal of the Statistical Department of H. M. Customs, I have been enabled to send you from time to time particulars of the value of the importation of honey. Whilst regretting that, so far, the authorities have not drawn public attention to the matter by including the article 'Honey' in their regularly published list of imports of Food Products, I feel sure all bee-keepers are grateful to Mr. Selton for personally undertaking to supply us with figures of so much interest to us all. Below is appended a *resumé* of the amounts for the twelve months of last year. The sum total will probably fall short of the estimate of many people when compared with the far vaster sums we annually pay to the foreigner for such articles as butter, eggs, &c., but it nevertheless seems sufficiently great to furnish us with a strong argument in favour of pressing the home production. It must, however, be borne in mind that these figures by no means represent the capacity of the community to consume honey, the sale of that article being still almost entirely undeveloped. Probably not one grocer in every ten even deals in the commodity, and as long as the sale is confined, as at present, chiefly to chemists and druggists, the consumption is sure to be small. The bee-keeper's best customer ought to be the poor man, and he must be taught that honey, pure and unadulterated, is a more wholesome and nutritious food than the many products he now buys under the name of jam. The Americans are wisely developing their home markets by leaflets, pamphlets, and notices in their public prints on honey as food, &c., and it is of the utmost importance that we also should bestir ourselves and do the like.—E. H. BELLAIRS, *Wingfield, Christchurch, 18th Feb., 1884.*

A Table showing the value of Honey imported into the United Kingdom during the twelve months of 1883.

January ..	£1612	August ..	£6262
February ..	2175	September ..	972
March ..	1535	October ..	725
April ..	1518	November ..	1908
May ..	471	December ..	1260
June ..	3534		
July ..	7496	Total	£39,778

[We are under a debt of gratitude to Mr. Bellairs for the trouble he has taken in enabling us to publish the value of the honey imported from month to month into the United Kingdom. The knowledge thus acquired is important and interesting; and were it not for the peculiar sources open to Mr. Bellairs, we should have sought for the information in vain. We trust Mr. Bellairs will continue his kind services during the current year.]

### FOUL BROOD AND WILLOWS.

A good deal has been written from time to time in the *British Bee Journal* about foul brood and its means of cure. It is generally treated with salicylic acid in some form. Mr. Abbott says, on p. 83, vol. ix. of *B. B. J.*, that salicylic acid is obtained from willows, and further states that since his palm-bearing willows began to bloom he has scarcely been troubled by this fatal disease. My own bees have sometimes suffered dreadfully from dysentery, and this, as is well known, often turns to foul brood; but I have never had a single case in my apiary, nor have I heard of one in this neighbourhood, where palm-bearing willows abound.

I feel satisfied that, where they are sufficiently numerous, foul brood will not occur; and besides their great value in this respect, they also produce great quantities of pollen in spring, which bees seem to prefer to other.—A. W. CHAYTOR, *Middletown, Yorkshire.*

### ECONOMY OF SPACE IN THE BROOD-CHAMBER.

This subject is one of the greatest importance, and yet there are very few indeed who pay as much attention to the matter as they should do. Some use a 10-frame hive, others 12, and so on, and possibly know how to work their stocks up to their respective numbers by the time honey is to be obtained. The supers are then placed on, and the brood chamber is left at its full capacity for the remainder of the season. And why not? say they; it is crowded with bees. Just so, and yet in many instances the bees show a great reluctance to enter the supers.

If honey is to be obtained at all I have never yet seen the colony that could not be induced to work in the sections above the brood-chamber, simply by reducing the number of frames below.

I do not care how many brood-combs the bees will occupy to advantage previous to the honey flow, but as soon as that time arrives all reserved for the production of comb-honey are reduced to just so many as will crowd the bees right into the sections when work commences at once. The surplus combs are given to stocks run for extracted honey, or to nuclei, or with adhering bees several of such sets are placed together to form new colonies.

As I have stated in a previous number, I generally use nine frames at the time of supering; but as August comes upon us, who has not found the greatest difficulty in keeping his bees at work in the sections, even though honey is being brought in? Many have said at this time, they were sure their bees had swarmed and gone away, when in reality the change has been caused by the colder nights compelling the bees to crowd closer together. The loss of heat and numbers consequent upon the annual slaughter of the drones, is also another cause of the deserted appearance of the super.

At this time all but five or six of the brood-combs should be removed, and the vacant space closed up with division boards. The later stores will then be placed in the sections instead of the brood-combs, from which it would have to be extracted and sold at a loss-price, though in the case of heather-honey extracting is out of the question. I have had excellent results by reducing the brood-combs to only four towards the close of the season.

Those who fail to get their stocks up to the desired strength by the time the first honey-gilt comes, will do well to stop spreading brood there and then. For is it not better to place a few sections on only five or six frames, and obtain some little honey, rather than build the colony up to the full extent of the hive at the expense of the incoming stores?

Where combs are removed towards autumn some will contain brood. These I have no trouble to dispose of in



my large apiary. Those who have a limited number can place a number of such combs and adhering bees in a new hive. Most of the old bees will return, but by that time there will be sufficient young bees hatched out to keep up the required temperature. These may be made to take care of any young queens that are required for superseding others; and when the season is over they should be united to the desired colonies. If no queen be given then of course they will raise their own, but before they are ready to lay the combs will be clear of brood. What honey there may be can then be extracted, and the bees united to some other lot as required.

One other advantage I find with this plan is that the work of winter preparation is greatly lessened, and the bees are in the best possible condition for feeding as soon as the harvest is over.—SAMUEL SIMMONS, *Rottingdean, Brighton.*

#### \* SILENCE GIVES CONSENT.

Statements have been circulated to the effect that I expressly prohibit the use of smoke while introducing queens. Permit me to say that in no single instance, either in my pamphlet or otherwise, have I forbidden the use of the bee-keeper's indispensable friend. It is so generally understood that smoke is necessary during manipulation, that I deemed it superfluous to give instructions on that point. The misunderstanding may possibly have arisen from a mistaken idea of the fact that I mention queen and bees should be disturbed as little as possible. I am so well acquainted with the conditions necessary to a successful introduction, that I *always* use the 'soothing' influence of smoke, and (except during a honey glut) should consider it the height of folly to neglect that important item, and thus create the worst of all disturbances—an angry feeling against all intruders, and by so doing simply court disaster.—S. SIMMONS.

#### SALE OF HONEY.

The idea of starting a Central Depot for the sale of honey, &c., having been at last abandoned for various reasons which were almost unanimously approved at the General Meeting on the 20th inst., after most patient and zealous exertions, on behalf of the sub-committee appointed long ago to investigate the matter and propose a scheme, it occurred to me, and some other county delegates to whom I spoke on the matter, that if a certain space in the *Journal* headed 'Honey for Sale' could be assigned to bee-keepers having honey to dispose of, a want which is *very commonly believed to exist* would be met, and give great satisfaction to many. The charge for such advertisements being as low as possible. *Members of County Associations only*, say the same as in the *Exchange and Mart*, viz., 4s. for twelve words. Personally I have never had a difficulty in getting rid of some 3 cwt. of comb and extracted honey at from 1s. to 2s. per lb., but I know well this is not the case with all, and I am constantly asked, 'What facility will be afforded me by the sale of honey if I join the Association?' If every advertiser at the reduced rate were required to publish his full name and address, stating the County Association to which he belonged, or to send with his advertisement a certificate of membership from his county secretary (in which case his name need not be published), there would be little danger of the privilege being abused.—W. E. BURKITT, *Hon. Sec. of Wilt. B. K. A.*

[We shall be pleased to afford every facility for enabling members of County Associations to dispose of their surplus honey, and before the honey harvest arrives will be in a position to state the lowest possible price for the insertion of such advertisements.]

#### LOWER GRADE OF EXPERTS.

I can fully endorse 'Platelayser's' remarks on lower class of experts. As a clergyman I have been associated with the labouring classes for many years, and have always endeavoured to become intimate with them; but I always find a certain amount of reserve or timidity which prevents them from *volunteering* a friendly discussion on any subject. 'Platelayser' says, 'It is a question with me which of the two will benefit the intelligent cottager the more—one of his own class who has made his way and won his spurs by sheer perseverance, or a gentleman who has subjected himself to the cramming process, and thus acquired in a few months what it took the other years to learn.' (I wish he had been rather more courteous in the word 'cramming,' &c.) It is no question with me at all.—I feel quite sure that a labouring man in friendly conversation with a fellow-labourer, who is well up in the practical working of bee-keeping, would learn far more than he would from a gentleman who may hold a first-class certificate.

Again, if an expert from the south were to come up among these dales, he would not understand the people, and I don't think they would understand him. I think there would probably be a score or more lower-grade experts to one regular one, and how easy it would be in the rounds of the regular one to give a little extra instruction to the lower grades, and thus a greater amount of work would be more efficiently done with less time and trouble. As to a 'convenient time and place' for the examination of experts, I must say that it would be a great boon to us in the north if an examination could take place somewhat nearer than London. I should like to compete for a certificate, but the expenses (about 10s.) put it quite out of the question.—LEARNES, *Wearside.*

#### LOCAL EXPERTS.

As you are doubtless aware, many of our County Associations feel greatly the want of local experts. The expense of sending to any distance for an expert is a considerable drain upon the funds of any Association, especially of one newly formed. The Committee of the Breconshire Association, in their report just issued, state 'that they feel that progress is much hindered for want of a local expert who could visit the apiaries of members at the critical periods.' Different to other Associations, this want with us can only be effectually supplied from local sources, for this reason, a large number of our members, the cottagers almost without exception, are Welsh-speaking, and, unfortunately, understand no language except their own. An English expert, therefore, however competent a bee-master he may be, would be quite incompetent for our purposes, or, I ought to say, could not do our work satisfactorily. A correspondent, in a recent issue of the *B. B. K. A.*, advocates experts' certificates being issued by County Associations. Equite agree with Mr. Raymond's reply that this would be unfeasible. What other course then remains open? This, and as far as I can see, this only, namely, that the expert examinations of the B. B. K. A. be held more than once in the year and at different places. If it is considered practicable to hold a second examination during the Royal Show this year, it will be a great convenience to intending competitors from Wales and the West of England. Next year the Show will be held in another part of the kingdom, which would then in its turn benefit therefrom. My only reason for advancing this suggestion is, because I think it would, if it could be carried out, prove beneficial to the B. B. K. A. and its county branches. You will, I trust, pardon me for referring to another subject, connected with the last, viz., the different grades of experts. A man who holds an expert's certificate is naturally expected to be a thoroughly competent bee-master. If this is granted, why the three grades? A man, I take it, is either a

bee-master, or he is not. Could not the classes be reduced to two, the only distinction between which to be that the first should be competent to deliver extemporary lectures upon any subject connected with bee-keeping, equal competency to be required in all other respects? I hope you will pardon me for troubling you at this length. I am unable to attend the meetings of the B.B.K.A., much as I should like to do so, on account of the distance from town, and the time it would take. The affairs of our County Association take up, perhaps, more time than I am justified in giving them, but the cause is a good one, and one in which I am deeply interested. What I have advanced has, possibly, been advanced before, and therefore I thought you would be kind enough to weed the matter, and should anything be left after that operation, bring it forward at a suitable time. You will, I know, be pleased to hear that our Association is in a satisfactory condition, which is to be attributed to a great extent to the generosity of the Central Association in sending Mr. Blow down to us in April last.—L. OSWALD LEWIS, Hon. Sec. *Carmarthenshire B. K. A.*

#### SHALL WE PRODUCE COMB OR EXTRACTED HONEY?

I thoroughly endorse the remarks made by Mr. Simmins with regard to the price of honey in your last issue. It is all very well to talk about selling extracted honey at 1s. per lb. and comb honey at 1s. 4d. per lb., but where are we to get the price? Here, in Cambridgeshire, we can only get for extracted honey in the retail market 8d. per lb., and for comb honey our price very seldom exceeds 1s. per lb. If your correspondent, Mr. W. B. Carter, will inform me where we can obtain the price he mentions, we shall feel much obliged to him.

Taking into consideration the time and labour employed in taking extracted honey, I think it is better to produce comb honey, as Mr. Simmins says 'it finds a more ready sale,' and can be obtained in a much easier way, and with less trouble than extracted honey. We may in some districts obtain more extracted honey than comb, but after comparing the price of one against the other, I think we may say that it is most profitable to cultivate the production of comb honey.—A. S. BRANT, *Sturston, Cambridge, Feb. 29th, 1884.*

#### WINTER DRONES.

While examining a stock of bees on the 30th of November last, I was greatly surprised to find a quantity of drones living apparently in perfect amity with the rest of the population, though the hive contained a fertile queen and a lot of healthy worker-brood in all stages. The stock, I may mention, had been queenless some time before the 24th of October, when a few condemned bees, with their queen, had been united with it. I had an opportunity of looking at them again about the 28th of January, but the poor old fellows could not be found.

Bees generally are in very good condition, but some are becoming short of stores. Breeding has been carried on more or less all through the exceptionally mild winter. I fear we shall have a prevalence of cold easterly winds again this spring to mar our hopes of a harvest from the fruit-blossom.—ROLAND GREEN, *Rainham, Kent.*

#### HONEY REFINER.

My extractor being too flimsy to work well, I had a galvanised iron case made—large enough to leave a  $\frac{1}{2}$  inch space all round and under it, with brass screw in top rim, to admit hot water, a ditto in side close to bottom to let out cold; a small pipe carried half-way down the side of extractor and under nearly to summit of coned bottom, allows hot water to fill the same.

I place extracted honey in this, fill the space with boiling water, cover machine with a large wrapper to retain heat, find that the unripe honey quickly rises to the surface.—G. J. LENNY, 185 *High Street, Lewes, Sussex.*

#### GREEN'S REMOVEABLE FRAME-ENDS.

Will you permit us to point out a slight error which appears in your issue of the 15th ult., under the heading, 'Harrison's Removeable Metal Ends?' You say, 'Dr. Pine was first in the field with his metal ends for frames having an open top; then came Mr. Blow's, with the top closed in.' Now in 1881 we exhibited and took prizes for hives at the Kensington Show, Dairy Show, &c., with frames having metal ends, the first, we believe, ever used, and it was not until the next season, 1882, that Dr. Pine came forward with his, which is certainly an improvement on our original one in some respects.

Since the Annual Show in 1881 all hives sent out by us have been furnished, unless otherwise ordered, with frames having our metal ends, so that a great quantity of metal-ended frames were in use prior to the introduction of Dr. Pine's or Mr. Blow's. We have enclosed samples of the end used first, and also the one we send out now. Most of the metal ends now in the market we consider objectionable in standing above the level of the frame-tops, making a nice (?) place for propolis when quilts are on, and awkward for the majority of super crates; and those that raise the frame about 2 in. are equally so, neither being perfectly interchangeable with standard frames.—GREEN AND SONS, *Rainham, Kent.*

#### Echoes from the Hives.

*Sussex.*—The season is early, and bees are early. All well-stored colonies have been breeding almost imperceptibly for some time, and are now stronger than after the autumn feeding. In no case has the brood nest been extended beyond what the dense mass of bees could have protected, even had the long-expected frost put in an appearance. At present there seems no possibility of severe weather, though, if we have no frost, we can hardly expect to escape the usual cold winds. The 14th Feb. was the warmest day we have had; not a breath of air, and bees were on the wing as if in mid-summer. The very next day a severe wind was blowing from the east. This continued until the 19th; on the 20th I offered the bees pea-flour, which they eagerly appropriated, and every morning since they have been hovering around the large forcing frame, ready to obtain what they know to be inside, the moment I open it; notwithstanding some 5000 crocus's, and a much larger number of wallflowers, which, however, receive a due share of attention. Feeding, so far, has been permitted only with a few colonies that were short of stores when bought in autumn.—SAMUEL SIMMONS.

*South Cambridgeshire, Sturston.*—The winter here has been favourable for bees. It has been very mild, and scarcely has a week passed by but what, when the sun was shining, the bees have ventured out on to the lighting-board. During the present month, when the days have been mild, they have been flying freely. I have not found any short of food, and there seems to be a fair average number of bees in the hives. The weather is very changeable; sometimes we get a very warm day, almost like summer, and then a day with a bitterly cold east wind blowing, which keeps the bees inside. If the weather continues mild I expect we shall soon begin spring-feeding. In this district the bar-frame-hive is getting more widely known since the formation of the Combs and Isle of Ely Bee-keepers' Association, but there are still a large number of old bee-keepers who will not admit the advantage to be gained by this 'new-fangled system' and this 'scientific mode of keeping bees,' but prefer to

keep them in skeps, and burn them over the horrid brimstone pit, as they have been accustomed to in times gone by. For the past few years we have not had a good honey season; but when it does come, and we can show them that by the use of the bar-frame hive they can double their income, we may fairly judge that the facts presented to them will be sufficient to convince them of the superiority and efficacy of the bar-frame hive.—A. S. B.

*Kewick, Cumberland, Feb. 16th, 1884.*—The weather here has been very rough the last three weeks; it has been almost continually raining, with strong winds. On the 27th of January, I had a hive blown over, and I most of the bees perished; there were a few hundreds still alive between the combs. I took them in the house and put a warm quilt on them, and brought a good many of them round in the hive, and a few hundreds I brought round before the fire, and put them in the hive again. Bees have not been flying as much lately as they have done previously, with so much open weather. I find their stores almost consumed. On the 14th of February we had a splendid day, and the bees took the advantage and showed themselves in the open air; this, of course, would give them a good airing, and I noticed them visiting the crocuses, of which I had a good many in bloom, though they are too early for being of much service to the bees. My hives are all alive and well at present, but I am afraid we shall have a hard spring to contend with. I have thirteen stocks of bees, though some are not very strong. I have made my stock of hives up to twenty-three this winter, those I am in hand with are after the style of Mr. Abbott's Anglo-German hive, they are single (not twin-hive) with moveable front, or part of the front can be put to any part of the hive for wintering. The floor-board is a fixture, and can be cleaned out at the front, and for living natural swarms they are very convenient, as there is no need for propping up the sides or front, as is the case with other hives; the front only needs sliding up a few inches, it then gives them the full breadth of the hive to enter. The sliding entrance is attached to the front board. The porch is the full width of the hive front. Double walls well packed with saw-dust, hard wood runners, the outer walls project four inches above the inner walls, with a good strong cover. I make from French currant-boxes, from grocers, except the floor-boards. The length from front to back is eighteen inches. The first lot of hives I made was from instructions I got from *Modern Bee-Keeping*, but I find them too small for general use. It was through that book I got my first lessons in bee-keeping, and I can speak well of it. I thank Mr. Simmins for giving his ideas on section-making, they will be very nice, and easy to make. ROBT. PHILLIPSON.

I omitted stating that the moveable front has a strip of cork on each end, so as to fit well and tight, and easy to remove.

*West Gloucestershire, Feb. 25th, 1884.* The weather since the 26th ult. has been mild and very changeable, no two successive days alike; fog, rain, hail, and showers, with occasional rough wind, predominating, except on the 14th inst., which was as warm and bright as a day in May, bringing the bees out as strong as though they were swarming. Crocuses are now in full bloom, but the stormy weather prevents the bees from deriving much benefit from them. R. W. L.

*Hunts, Somersetshire.*—From Jan. 24th to 29th wind in south-west, and weather cold and stormy, average highest temperature 40°, average lowest temperature 32°. From Jan. 29th to Feb. 14th the weather was very fine, the wind being almost the whole time in south and south-west—average highest temperature 48°, average lowest 38°. From Feb. 14th to 29th we had cold easterly winds. Since the latter date the wind has been almost wholly in the south, and the weather has been very mild; temperature over 50°. Bees are now almost mad on crocuses

and pea-flour. I believe breeding is going on rapidly. I have only opened one hive, which I thought short of stores, and found the queen and a nice lot of eggs. I hope we shall have a more favourable season in this district this year.—C. N. WHITE.

*Eresham, Feb. 24.*—The weather here continues very mild, and the bees are flying nearly every day, and gathering pollen from the crocuses and snowdrops, which are out in profusion. I examined five stocks of bees one day last week, not having opened the hives since they were made secure in the autumn. I found large patches of brood on four or five frames in each hive, young bees hatching out, eggs just newly laid, and grubs in all stages. I have been feeding a little during the last month with barley sugar, but the bees have enough honey sealed up to last them a considerable time longer. At present everything here augurs for a very early season.—A. H. MARTIN, *Hon. Sec. Worcester B. K. A.*

*Blackheath, Kent, Feb. 25.* Now that the winter seems over, and spring upon us, it may be well to record how the hives with their inhabitants have fared in this district. I find my bees to be all in a very healthy and fine condition, having survived the winter well. This may be accounted for in a great measure by the mildness of the season. I put down a great deal of my successful wintering of bees to the plan I have always adopted, viz. leaving them plenty of honey in their hives, and not feeding them artificially; and then by carefully looking at them from time to time so as to ascertain how they are progressing, and in what condition they are in. In the spring I always give them some sugar-candy in addition to the honey they have of their own by placing it under the cloth covers on the top of the frames. In the majority of cases hives are lost during the winter from not looking and carefully watching the stock of food, the hives simply being left to starve. Year after year we hear of owners losing their bees and getting disheartened, when by leaving them sufficient honey, by properly protecting them from the cold, and by constant attention during the winter, they would, in almost every instance, have saved them. HARRIS S. SAUNDERS.

*Cairnshy-Kith, N.B. Feb. 19th.* Last November I bought a lot of hives at the point of starvation; as soon as I got them home I began to feed, but owing to cold weather setting in two of them did not get quite enough, one was a wooden box with fixed combs, the other a common straw skep. To-day both of them were taken into the shop for the purpose of being inspected. I did not know the weight of the box, and I could not see my sealed stores. A number of holes were bored in the top of box until a square opening (about 1 inch) was cut right out. I was glad to find they had a little food, more, indeed, than I expected. Having a stock of candy I plastered up the opening, then a board was put on to keep all tight. The straw skep was treated in the same manner, and was found in far better condition than I expected, of course their stores are rather limited, but the examination revealed how long they would last. Kindly permit me to give the following advice, perhaps it may help some one, viz.—Don't delay making an examination of all suspected stocks, if the weather is cold take them indoors, many stocks could be saved by a timely examination.—A. COCKBURN.

## Queries and Replies.

QUERY No. 745.—(A. COCKBURN.)—*Bee Flowers.* I beg to thank Mr. Ingham for his practical articles in the bee-flower line, and I would like to ask him if the snowberry would be suitable for a hedge; I have some of it, and I am rather inclined to think it would. If, however, there is anything more suitable for a honey-yielding hedge, and easy of cultivation, I would like to know all about it.—

A. I have great pleasure in complying with Mr. Cockburn's wish that I should offer an opinion as to the suitability of the Snowberry for forming a hedge. The shrub might very well be employed as a divisional fence between gardens or where a hedge is not expected to be impervious to man and beast, but alone and unsupported it would be insufficient to resist the encroachments of cattle; but two strained wires held up by posts passed through it would make it efficient as a hedge, and it would be both ornamental and useful to bee-keepers; a shrub like this that possesses the good qualities of a hardy constitution, great freedom of growth, even under timber trees, or producing flowers attractive to bees, and rich in nectarous secretions, unquestionably deserves more extensive cultivation; and employed exclusively, or even introduced into hedges, its merits as a bee-flower would soon be acknowledged by neighbouring bee-keepers. It is a shrub that can be planted advantageously in covers, as it escapes the depredations of rabbits, and in masses it forms a good protection to game of all sorts. I think Mr. Cockburn's idea a very happy one, and I shall not lose an opportunity of trying it.—W. INGRAM, *Belvoir*.

QUERY No. 746.—(D. Young.) *Dahlia*.—Are dahlia flowers, single or double, injurious to bees?—A. Blooming late in autumn, when other flowers favoured by bees are declining, dahlias, and particularly the single forms, are likely to attract them, and we should think that if any influence be contributed by the dahlia, it would not be a favourable one. Better grow mignonette and bugloss to divert them from the dahlias, or cease to grow dahlias. We have not remarked in our bees any inclination for this flower, and we have no intention of giving them the opportunity. It is not unlikely that the dahlia is injurious to honey, particularly when other flowers are about, and bees resort to it and gather its products freely.

QUERY No. 747.—(ABERHONDU.) *An Evicted Hive*.—On a cold frosty morning (Jan. 27th, ult.) one of my straw hives showed at 9 a.m. great signs of excitement. I turned the hive up, but could discover no cause for the uproar. The next day I gave a cake of candy, but the bees still continued to come out in great numbers, the other hives being quiet; the hum too was kept up in the hive until dusk had passed for several hours. The hive was filled with two swarms of driven bees late in the autumn, and it was and is of fair height and well filled with bees when I turned it up on the 28th ult.—A. It is to be feared that your bees have lost their queen—it may be from old age or other cause, since, in the absence of robbing, we can assign no other cause for the long-continued excitement and commotion you describe. We advise you on the first bright warm day to drive the bees and ascertain whether they possess a queen; if not, it will be best to unite them to another colony.

QUERY No. 748.—(C. W. H.)—1. *Galvanised Iron Vessel*.—I was going to get a galvanised iron vessel from one of the bee-appliance makers, but I observe that Mr. Cowan says that galvanised iron hurts honey: is this a recognised fact? Would there be any objection to a small sherry cask, if well scalded out, used for syrup in spring, and after again washing out, being used for honey in summer?—A. We certainly should not recommend a galvanised iron vessel as a receptacle for extracted honey. For this purpose casks are invariably used in America, and are undoubtedly the best. Those you proposed will answer your purpose well, but you would do well to keep the honey and syrup casks separate. 2. *Artificial Swarms*.—I wish to make a early strong swarm for a large hive. Would it do put to (say) eight frames of brood from other hives in this one and set it between the positions occupied between B and C, which are very close together, removing these to new positions? Would the bees of B and C, on entering the new hive, fight with one another? It is not convenient to take out frames from

B or C, as they will not take Association frames used in the rest.—A. We do not recommend the proposed plan, since confusion and fighting would probably occur. Either make your artificial swarm in accordance with the usual plan of dividing, or wait for the natural swarm, when you can divide or equalise the colonies according to their strength, taking advantage of weather, honey-flow, or other circumstances being favourable. 3. *Ligurians and Hybrids*.—Ligurians are gentler than blacks, I believe, not so hybrids. Are the latter from Ligurian queen mated with black drone more spiteful than ordinary black?—A. The hybrids bred from an Italian mother are generally more gentle than those bred the other way.

QUERY No. 749.—(W. NICKELL.)—1. *Transferring Combs*.—How can I transfer the bees and combs (which are very uneven and propolised) to those of the Standard size, as all my others are?—A. It is a very simple operation to transfer the combs from larger frames to smaller. Brush the bees off one comb at a time, lay the frames on a board, cut the comb out, and cut it to fit the Standard frame tightly—force it into the frame, keeping the midrib in the centre of top bar. (See Reply to 'A Novice'.) 2. *Spring Treatment*.—I examined my bees a short time since, and found they had taken part of the candy, but the combs are only about three parts built out. What would be the best steps for me to take respecting them?—A. As your bees increase in number they will build out the combs and occupy them. To make use of candy, they require water: give them a supply in the form of thin syrup.

#### NOTICES TO CORRESPONDENTS & INQUIRERS.

LOVER OF BEES.—1. *Foul Brood*.—Stamp it out at all cost. Do not let any ideas of economy induce you, for the sake of saving a hive, to lose your bees, not only present but future. You can do nothing at present, except to spray the combs and bees with solution of salicylic acid, as recommended in the books which you have. When the weather is warm enough for comb-building, remove the bees from the combs, and keep them shut in a box with ventilation for forty-eight hours, to give them the opportunity of digesting all the honey which they have in their sacs, and which would be infected. Then give them, in new hives, or hives which have been very carefully scalded and disinfected with salicylic acid, foundation to work out, and plenty of syrup or honey (which must not have been taken from an infected hive) containing the acid. Boil down the old combs, and be most careful that neither the bees from clean hives rob the infected ones, or that bees from the infected hives enter the others. Wash your hands and all utensils employed about the infected hives, before touching the clean ones, with solution of salicylic acid. The box in which the infected bees are confined must be destroyed, or, at any rate, not left about for bees to get at. 2. *Hive Making*.—You are quite right to use 11 in. boards for the outer walls, but instead of using all the difference above the frames, let the floor-board be inside the outer walls and at least  $\frac{1}{4}$  in. up, so that no damp can draw under. The queen-excluder must fit closely between the inner walls, between the brood nest and the section frames. It is not required for sections on the top, as the spaces left between them will exclude the queen.

A NOVICE.—*Crooked Combs*.—1. If the combs are simply elongated irregularly, you can cut the cells down, and turn them round so as to present fresh faces to each other, and all will be straight. But if, as we suspect, the midribs are crooked, you ought to have straightened them when transferring: leave them alone for the present, and when the weather is warm, cut out the combs, cutting down to the midrib

on the convex side, press the comb flat, then tie into your frames again, keeping the midrib in the centre of the top bar; never mind the outsides, if the midrib is straight you are right. The small amount of brood sacrificed will be of no moment. 2. *Feeding*.—Keep the hive contracted to the smallest number of combs covered by bees, and do not think of enlarging it until plenty of bees are hatching, at least twenty-five days after breeding begins.

A. M.—*Spring Feeding*.—Four pounds of sugar to the quart of water will be a very good syrup for stimulative feeding, but if to give food to prevent starvation put 5 lb. or 6 lb. to the quart.

J. W.—*Ants in Bee Hives*.—Endeavour to trace the path leading from the ants' nest to the hive. Then take a paraffin can and liberally use its contents around the hive and on the pathway of the ants. Ant-cluster about hives for warmth.

H. J. SANDS.—*Salicylic Acid in Water*.—Putting salicylic acid in the water that bees drink, with a view to prevent foul-brood, will not be productive of much benefit, but it could do no harm. As an experiment it may be worth the trial.

C. R.—*Blackheath—Foul Brood*.—We are sorry to have to inform you that both the samples of comb, A and B, bear evidence of confirmed foul-brood. If we might hazard a conjecture, we should say that it had its commencement in the hive in the early summer. We should advise you to destroy all the comb, if not the hive also. It will be matter of surprise if the other hives in your apiary have not been similarly affected. Sample it has been attacked by moths, and spiders have made their home in the cells. Read carefully our reply to 'Lover of Bees.'

R. FOOTE.—*American Cloth*.—The American cloth would answer your purpose very well. Place it on the frame, and the quilt over it.

JOHN WILKINSHAW.—*Beeking Ware*.—W. vi. bleached by resmelling it and running it into thin sheets or cakes, suffering it to cool and exposing it to the influence of air and sun. It should be known that the process leaves it odourless and unfit for exhibition; in fact, scarcely discernible from some kinds of earth-ware.

H. SUTTON.—*Wandsworth*.—1. *Artificial Swarming*.—It is a very delicate operation using chloroform to save the trouble of driving. It requires to be done to a very exact nicety. We should prefer the use of puff-ball. It is to be borne in remembrance that when bees come out of the comatose state they are remarkably lively and vigorous. 2. *To ascertain the right time to make a Swarm*.—The right time is when the hive is crammed full of bees. If the bees are in a bar-frame hive, examine the outside frames early in the morning, and note if they are especially crowded; if in a skep, let it be raised and note if the bees are massed on the floor-board. 3. *Preparation of bees to be put into the Swarms*.—If the bees are in a proper swarming condition, a mere handful of bees taken with the queen and put on the old stand will be sufficient when augmented by those which will fly back. 4. Probably if the remaining bees be driven twenty-one days after first swarm they will be heavier than the first swarm was when made, unless they cast.

JOHN W. TOWNSEND.—1. *Observatory Hive*.—The proposed observatory is a very odd style. We do not recommend you to proceed with it unless it be considerably improved. Being three combs high, the bees are sure to desert the lower combs. The hive is unsuitable for bees in cold weather; therefore, excepting during the summer months, the combs and bees must be put into an ordinary hive. The frame-ends should therefore be longer than the hive is wide, so as to rest in rebats in the usual manner, and the sides of observatory should be cut as shown in the drawing we

have returned. The blocks, which support the frame will then be unnecessary. If you leave the frames as they are, the hive for winter would have to be furnished with similar blocks, which would cause the bees on the ends of the frames to be scraped off, and injured every time a frame was withdrawn. Even in the favourable position proposed the bees will be unable to do well even in warm weather, unless the sides be kept warm by well-padded shutters. We have made some further suggestions in your drawing. 2. The 'German grey' queen is only a grandiloquent mode of describing our common English black kind. We are not surprised that Mr. Benton was unable to satisfy your order. 3. There is no occasion for having carpet between the top of bars and crate of sections when bees are in full work.

W. B.—1. *Painting Inside of Hives*.—No; the book you refer to is full of mis-statements. You are right in your idea. 2. *Hatching Queens*.—You would not be likely to succeed in artificially hatching queens. The nucleus system is best, as there is no loss of time. But, by depriving one strong stock of the queen, and ten days afterwards, when queen-cells are ripe, artificially swarming your other stocks, and giving each a queen-cell, a great saving is effected. You may learn the details from *Modern Bee-Keeping*.

McK.—1. *Dead Bees*.—The dead bees found in the comb were caught there by a cold night, and chilled before they could join the condensing cluster. Had you made winter passages, they could have crept through the hole, although unable to traverse the cold combs to and round the edges. 2. *Transferring*.—If you do this it will almost certainly prevent swarming, as they will have so much more room in the bar-frame hive. Having transferred, you can at any time examine and remove queen-cells if any should be built. You may transfer, if expeditious, at any time when the weather is warm enough. 3. *Feeding*.—You may now safely commence stimulating.

A. BEGINNER.—1. *Locality for Bees*.—Your bees should do fairly well. They visit furze for pollen and esome say honey. Broom is considered to be a good plant for bees. The rhododendrons, for which your neighbourhood is famous, also afford some pasturage for bees. These, with wild flowers, clover, &c., will carry you on until the heather blossoms. You will get no end of propolis from the fir-trees. 2. *The Little Wonder*.—If heather honey be not extracted in the course of the first few days after it is deposited in the cells, neither the Little Wonder nor any other extractor can extract it. If it could be hurled out by the rapidity of the revolutions of an extractor, it would come out as solid pellets from the comb. For the treatment of heather honey see vol. xi., page 182.

ISOTHEMUS.—*Spring Feeding*.—It is very desirable that from about the beginning of March the bees should be aided by liquid food, slowly and continuously given. The amount given should average per day (or, rather, per night) from two or three ounces to half-a-pound at the beginning, and gradually increase in proportion to the strength and growth of the colonies, till such time as they can get food from natural sources. Spring feeding is a kind of mild deception practised on the mother-bee; the worker-bees assure her that spring has really commenced, and she is thus stimulated to lay eggs, which are the foundation of future colonies.

T. S. C.—The pieces forwarded are particles of pollen cleared by the bees out of the cells.

E. M. *Worthing*.—*Protection from Stings*.—An ordinary pair of kid gloves are not sufficiently thick to protect the hands from the stings of bees. A better protection consists of a pair of thick hand-knitted

cotton gloves, over which is worn a pair of gauntleted Berlins, wetted. It is easy to manipulate with these; they are perfectly ventilating, and easily cleansed.

**A. POOR AMATEUR.**—1. *The Journal.*—The *B. B. Journal* is always posted on the 15th and the last day of each month, within a few hours of publication. You had better have it forwarded direct by Mr. Huckle. 2. *Doubtful Comb and Honey.*—There is a similarity between the two cases referred to; but, inasmuch as the cause of the death of the bees is not clearly indicated, we consider it would be preferable not to use the combs for the purpose mentioned. The honey may be boiled for a short time, and, by adding to it salicylic acid, can be used for food for the other bees.

**M. HUMFREY.**—1. *Syrup Feeding.*—About the beginning of March the candy should be removed, and you may commence feeding with syrup. 2. *Making Syrup.*—If you make the syrup according to the directions given on page 67 of *Modern Bee-keeping* you will have no difficulty in preventing crystallization. 3. *Swarming.*—When your bees swarm, hive them in a skep or a metal pail; then jerk or pour them out on the sheet before the bar-frame, which they speedily enter. Another method is to hive them from the top. Remove some of the outer combs, and pour the bees into the space. They will soon cluster among the other frames. Then readjust the frames which have been removed, and place the quilt gently over them. (See previous numbers of *B. B. J.*) 4. *Foundations.*

Use foundations; they are inserted in the saw-cut of the frames, or they are fixed by using melted wax, or by Cheshire foundation-fixers. 5. *Sections.*—Sections should be put on when the hive is full of bees, the weather fine, and plenty of honey in the fields and gardens. 6. As there appears now to be every indication of the advent of spring, the winter coverings may be gradually reduced.

**R. WALKER.**—As there seems to be considerable doubt whether the combs may be considered to be sound and healthy it would be safer to destroy them, and furnish the hives with comb-foundation.

**W. ADAMS.**—1. Now that there is every probability that spring weather is approaching, the hives may be relieved gradually of the carpeting, &c., which were necessary in winter. 2. *Feeding.*—Feeding with syrup may be commenced early in March. The syrup should be made in accordance with the recipes found in Cowan's *Guide-book* for spring feeding. 3. *Non-swarming.*—When the bees give signs of swarming, it may be prevented by giving the queen more room for depositing her eggs by removing combs containing brood, and giving empty combs, or comb-foundations. For other means of preventing swarming see Cowan's *Guide-book*. 4. *Melting old Comb.*—As your residence is no great distance from Southall, perhaps Messrs. Abbott would make up your old comb into foundation. 5. *Pea-blossom.*—The bees visit pea-blossom, but are not very partial to it.

**C. H. BICKLEY.**—*Chilled Brood.*—The sample of comb is not a case of foul brood, but one of chilled brood. As this is an active cause of foul-brood, adopt every precaution to prevent its development.

**M.**—While the cause of the disturbance in the hive might possibly have been the loss of the queen, the bee forwarded was *not* her majesty. (See Reply to No. 747.)

**T. N.**—Cowan's Extractor is adaptable to the Association frame, but not to Neighbour's old No. 60 hive-frame, there being a difference of  $1\frac{1}{2}$  inches in width between the two. It is not desirable to use it for extracting honey from sections.

\* \* \* *The length to which the Report of the B. B. K. A. has extended has obliged us to postpone several communications.*

**BEE VEILS** (Improved) with Wire Gauze Fronts, post free for 18 Stamps. Address B. DRIG, Papworth-Everard, St. Ives, Hunts. (59)

**BEE-FLOWERS SEED.**—Borage, White Clover, Marjoram (Knotted), Mignonette, Linmanthes, Barton, Wallflower, Clarkia Alba, Mustard, Buckwheat; any of the above in 3d. or 6d. packets. Is. order post free. Address H. Y. DOBBIE, Cringleford, Norwich. 1876

**ILLUSTRATED CATALOGUE** Free anywhere. Pure Foundation, 2s. lb.; 5 lbs. at 1s. 10d. Best Sections, Is. 100. Superior Combination Hive, 21 ins. long, 8s. Prizes awarded to G. STOTHARD, Welwyn, Herts, at Fourteen Shows. 1886

**WANTED,** an EXPERT for the Hants and Isle of Wight Bee-keepers' Association, to arrange a SPRING TOUR, &c. Good Testimonials indispensable. A permanent Salary could be secured by one who would assist in duties of Assistant Secretary, &c. Residence near Christchurch preferred. Apply to E. H. BELLARS, Hon. Secretary, Wingfield, Christchurch.

**BEE-KEEPERS' GUIDE; OR, MANUAL OF THE APICARY.** 10,000 sold since 1876. Eleventh Thousand and 191 elegant Illustrations. Hundreds of copies of this work have been sold in England, and the many improvements will make it even more popular in Great Britain and on the Continent. Price by mail, \$1.25. Liberal discount made to Dealers and to Clubs. Address A. J. COOK, Lansing, Michigan, U.S. Author and Publisher.

State Agricultural College, Nov. 10, 1883.

## HEAD QUARTERS

FOR

## Comb Foundation, Sections, &c.

For PRICE LIST apply to

WILLIAM RAITT, Blairgowrie, N.B.

**E. M. HART & CO.,**

The LONGSTOCK HIVE Manufactory,  
STOCKBRIDGE, HANTS.

### SPECIALITIES:

HIVES, complete, from 6s. SECTIONS, V-ent, in 6 sizes. FOUNDATION, Flat, or natural base.

CLARK'S COLD-BLAST SMOKER. 'Far and away the best Smoker.' 3s., post free.

HART'S SIMPLEX FEEDERS. 'The easiest and best to manage.' 1s. 6d. each, 15s. dozen.

THE 'SWANMOORE' SECTION CRATE. 'The most perfect Crate made.'

The Trade supplied. Price List on application.

## Bee-keeping as a Business.

STUDENTS are accepted at any time at the GREAT SUSSEX BEE FARMS on reasonable terms. Almost anyone can keep Bees; but it is a fact that not one in fifty will ever make it a profitable business unless Practical Lessons are taken for at least one Season on a large Bee Farm, conducted on modern principles. Without such instruction, it takes years to acquire the knowledge necessary to ensure success in this most fascinating and health-giving pursuit.

As the Proprietor devotes his time entirely to the production and sale of Honey and Bees, those studying with him will have his undivided attention, and will be qualified to start out at once on a recognised system of management; thus saving much needless expense and labour conducted in a wrong direction. Particulars on application to S. SIMMONS, Proprietor, Great Sussex Apiaries, Rottingdean, Brighton. (47)

**Special Prepaid Advertisements.**

For Sales and Purchases of Bee Appliances, Honey, Books, Pamphlets, Diagrams, &c., Exchanges and Situations.

*Terms: Twelve words and under, Fourpence; for every additional three words, One Penny extra; no reduction can be made for continuous insertion.*

Advertisements will not be received for insertion under this heading from Manufacturers or Dealers in Bee Furniture, except for the Sales of Honey and Bee Literature.

**THE SIMMINS' METHOD OF DIRECT INTRODUCTION.** Enlarged to 32 pages. Price 6/1. Post free, of the Author, Rottingdean, Brighton; Messrs. Newbourn & Sons, 149 Regent Street; and Mr. J. HECKER, King's Langley, Herts. (53)

**NEW PERSIAN CLOVER**, highly fragrant, and a valuable Bee Flower. Very scarce. In small packets, 1s. each. Cash with order. **THE BEE-KEEPER'S FLORAL PACKET** contains Six Packets of Seed of Bee Flowers for Spring sowing, viz.: Borage, Clarkia, Melilot, Mignonette, Phacelia, and Echinum grandiflorum. Priced 3s. Cash with order. Address R. R. GODFREY, Grantham. (58)

**BEES FOR SALE.**—Being over-stocked, I will dispose of a dozen Stocks of Black Bees, cheap. Warranted in good condition. Frame Hives, Standard size, or Flat-top Skeps. Can be seen any time. Address JAS. GRANGER, St. Paul Street, Stamford. (66)

**ENGLISH and LIGURIAN BEES** in Bar-frame Hives for Sale. Also several new Bar-frame Hives, 15 in. by 15 in., 10 in. deep, to be sold cheap. Apply T. HILL, Scotland's Cannon Road, near Wolverhampton. (67)

**WANTED.** Second-hand Honey Extractor to take Association's Frames. Address ALBERT WILKINSON, Newbury. (68)

**FLOOR SALE.**—Three good strong Stocks in large Flat-topped Straw Hives, for Springing. Apply to FINEYS CLARK, High Street, Fother's Bar, Brimley. (69)

**FLOOR SALE.**—A Foot-power Circular Saw Bench, newly made, Oak frame, suitable for Hive making, with two Saws. Further particulars apply to T. OATS, No. 7 Staff, Corsham, Wilts. (70)

**FLOOR SALE.** Fifty Stocks of Bees in Association Frames and Double-walled Hives. Apply to R. FINNEY, Eveson, Shefford, Lincolnshire.

**WINTER LECTURES.**

For Sale in Hives.

A SET of LANTERN SLIDES, suitable for all the seasons.

For further Particulars and Specimens apply

**ABBOTT BROS.,** Southall, Mid Hsex.

**METAL ENDS FOR FRAMES.**

**NOTICE.**—We beg to call the attention of all Bee-keepers to our latest improvement in Metal Ends for Frames, which entirely supersede the use of Zinc Runners and Bead-shouldered Frames, while their weight and fixing keep the Frames perfectly perpendicular.

Price, 10d. per doz., 9s. per gross. *Specimens sent on receipt of stamp.* All Hives above 10s. each are fitted with these Ends.

*Illustrated Catalogue free on application. See Bee Journal, Nov. 1883 and Dec. 1883. First and Second Periodicals, Herts., Coventry, &c.*

**C. G. HARRISON & CO.,**  
Hive Makers and Dealers in all Apian Appliances,  
HALESOWEN, WORCESTERSHIRE. 1890

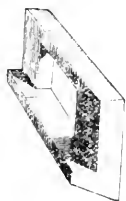

**THOMAS B. BLOW,**  
WELWYN, HERTS.

Manufacturer of Bee-keeping Appliances of every Description,  
And IMPORTER OF FOREIGN BEES,

**P**EGS to call attention to the unrivalled quality of his productions. By the aid of special power machinery he is enabled to combine moderate prices with high quality. More lowness of price is not so much aimed at as accurate fit and finish, all goods being adapted both for the convenience of the Bees and ease of manipulation to the Bee-keeper.

**ILLUSTRATED CATALOGUE,** 48 Pages, 50 Illustrations full of interesting and useful information, Free on application.

**THE HEREFORDSHIRE**  
**SCHOOL OF APICULTURE**

**S**UPPLY BEES, HIVES, and everything pertaining to Modern Bee-culture. HIVES made only of the best well-seasoned wood, a quantity of which is always kept ready cut and prepared for putting together. Awarded *Honourable Mention* for a Hive exhibited at Cork Industrial Exhibition, 1883, and *First Prize* at various County Shows. Revised Catalogue for 1884.

**J. R. W. HOLE,**

Export to Herts. B. K. J., Essex. B. K. J., Kent. B. K. J., London.

Address—TARRINGTON, LEDBURY.

**CASE (PREPARED)** for making Straw Skeps, 1 lb. (including packet) 6s. free per post, 2s. 3d.; smaller packets 1s., post free. SALICYLIC ACID, free per post, 1s. THYMOL, 1s. packets, too; cheaper in quantity. Address J. R. W. HOLE, Tarrington, Ledbury.

**IMMANUEL'S DOUGLASS' IS,** per 100, free; 1000, 7s. SNOWBERRY SHEDS, well rooted, two for 1s. free. Cheaper in quantities. Address J. R. W. HOLE, Tarrington, Ledbury. (68)

**CHARLES T. OVERTON,**  
Letchworth, Herts.

**THREE BRIDGES, SUSSEX,**  
Bees for all the different sorts of Bee-keepers to take.

**NEW STOCK OF BEE-KEEPING APPLIANCES** for 1884, and hopes to be favoured with their support.

*See Bee and Honey Monthly, and other Journals, and all Bee-keepers, Beekeepers' Clubs, Hives, and other Shows, in the Bee Journal, Beekeepers' Clubs, Exhibitions, &c. Illustrated Catalogue.*

Orders can now be booked for Frame Stocks, and Swarms, of ENGLISH, LIGURIAN, and other Foreign BEES, for early spring delivery, also imported LIGURIAN QUEENS. First consignment will arrive early in May.

**SPECIALITIES.**

The **COWAN HIVE**, and Extractor, Bee-hum smoker, the best in use; super-Honey Bees, Good Foundation, American Flat-top STRAW HIVES, with hole in top for feeding and opening, 2 each; Crabs of 18 1/2 lb. sections for straw Hives, 2 each, complete.

Order from Bees and their Management on wood by return of post, 10 stamps. Send 7d. for Model on card, 1/1 for British Beekeepers' Guide, 1/10 for any application.

**CHINA HONEY BOXES and JARS**, as sold at the Knightsbridge Show, may be obtained of Mr. J. HECKER, King's Langley. The Boxes are suitable in size for holding 1 lb. Sections, and the Jars about 1 1/2 lbs. of Extracted Honey, both are very ornamental and convenient for the Breakfast Table. Price reduced to Boxes 2/6, Jars 1/0. Can be forwarded by Parcels post on payment of the cost of carriage, amounting to 6d. for one Box; two Boxes, 9d.

**SYRIAN BEES.** I am making arrangements to supply EARLY SWARMS, headed by imported 'Benton' Queens, from 12s. Those who dread the risk of introducing valuable Queens should be sharp. Address JOHN HEWITT, Sheffield.

Common Swarms or Stocks wanted.

# MAIDSTONE SHOW PRIZE LIST.

Monday, June 2, and Four following Days.

**SCHEDULE OF PRIZES** offered by the **BRITISH BEE-KEEPERS' ASSOCIATION.**  
**ENTRIES** close 16th of April, 1884. Forms of Entry will be supplied upon Application to **MR. JOHN HUCKLE**, Secretary of the British Bee-keepers' Association, or to **MR. JESSE GARRATT**, Secretary of the Kent Bee-keepers' Association.

**CLASS.**

1. For the best Hive for observation purposes, all combs to be visible on both sides, to be stocked with Bees and their Queen ... .. 20/0 10/0
2. For the best Frame Hive of a substantial character for general use in an Apiary, price not to exceed 15s. 20/0 10/0

3. For the best Frame Hive for Cottagers' use, with arrangements for Summer and Winter, price not to exceed 10s. 6d. ... .. 20/0 10/0

4. For the best collection of Hives and Bee Furniture most applicable to modern Bee-keeping; no two articles to be alike ... .. 40/0 20/0

Each collection must not contain more than two Observatory Hives; two best Frame Hives, two Hives price not exceeding 15s. each; two Cottagers' Hives, price not exceeding 10s. 6d. In judging, recent improvements and new inventions will be taken into consideration.

5. For the best Super of Honey (not being a sectional Super). The Super to be of Wood, Glass, Straw, or of wood in combination with glass or straw 20/0 10/0

6. For the best twelve 2-lb. Sections of Comb Honey  
 Silver Medal of the British Bee-keepers' Association;  
 Bronze of ditto; Certificate of ditto.

7. For the best 12 1-lb. Sections of Comb Honey 20/0 10/0 5/0

8. For the best exhibition of run or extracted Honey in 12 2-lb. or 24 1-lb. glass jars ... .. 20/0 10/0 5/0

**CLASS.**

9. For the best sample of Comb Foundation made of pure Bees-wax, in the presence of the Judges, to consist of 2½ lbs. thick (Worker Cells) for Stock Hive, and 2½ lbs. thin for Supers. The appliance used for making the Foundation to be exhibited at work at intervals during the Show ... .. 20/0 10/0

**RULES AND REGULATIONS.**

1. All Exhibits must be sent Carriage paid, and delivered in the Show yard not later than 4 p.m. on Saturday May 31st.

2. All articles must be *bona fide* the property of the Exhibitor.

3. All Honey must have been gathered in the natural way by the Exhibitor's own Bees.

4. All Supers and Sections of Comb Honey must be glazed, or exhibited in crates protected by glass sides. If each section be glazed, the glass must be attached in such a manner as to be easily removed by the Judges for examination in making their awards.

5. The selling prices of all Hives entered for competition in Classes 2 and 3 must be stated in the Certificate of Entry; otherwise, the entries cannot be received. Exhibitors in these classes must undertake to supply any number of similar Hives during the ensuing twelve months at the prices named in their Certificate of Entry.

6. Entrance Fees.—For Members of the British Bee-keepers' Association, and of the Kent Bee-keepers' Association, in Class 4, 5s. each entry; in all other classes, 2s. 6d. each entry. Non-Members of the respective Associations will be charged double these Fees.

**SERVING COMMISSION.**—Every Exhibitor who displays goods *For Sale*, will be required to pay for the space occupied by his exhibits the sum of 2s. per foot run of staging.

## 'THE RELIANCE' BEE FEEDER.

An entirely new and very simple contrivance for SPRING and AUTUMN FEEDING.

It is thoroughly reliable, and is specially arranged for WINTER FEEDING with BARLEY-SUGAR.

Price, with Bottle complete, 1s. 6d. each, or 6 for 8s.

Address T. B. LATCHMORE,  
BRAND STREET, HITCHIN, HERTS.

## BEE HIVES and APPLIANCES

Of the best quality, at the lowest possible price, to be obtained from

**JOHN LEAKE, JUN.**  
BEACON STREET, LICHFIELD.

COTTAGERS' HIVE, made of 1 inch best Pine, planed outside, contains 9 Standard Frames and Dummy, resting on Tin Runners, suitable for Bee-Shed. Price 4s.

ABBOTT'S HONEY EXTRACTOR, best make, 9s. 6d.

BINGHAM SMOKER, neatly and strongly made, 3s. 6d.

Other Appliances at an equally low rate. 5 per cent. discount off all Orders up to April 1st.

Send Card for PRICE LIST to

JOHN LEAKE, Jun., Beacon Street, Lichfield. 1838

**CUSTOMERS** and others whose Orders were delayed last season should order at once. My 10s. FIRST PRIZE KENSINGTON HIVE has not yet been surpassed, and has been ordered and sent to Bee-keepers beyond the Atlantic. Other HIVES from 3s. 6d. upwards. Hundreds of testimonials. Please send for Price List and see a few of them. Address A. COCKRIN, Bar-France Hive Manufacturer, Honey Grove, Cairnie-by-Keith, N.B.

## Imported Cyprians & Syrians.

**T**HE undersigned will visit Cyprus and Syria this Winter, and bring back full Colonies and Nuclei, with only selected Queens, part of which will be raised by himself in March. Fine Queen sent before June 1st, 22s.; during June, July, or August, 20s.; after September 1st, 18s. These are to be Selected Queens of fine grade. A limited number of exceptionally prolific Queens can be supplied at an additional price of 5s. each.

## Imported Carniolans & Italians.

Fine Queen before June 1st, 9s.; Extra Fine, 12s.; during June, 8s.; Extra Fine, 10s. I accept and send out none but Choice Queens. The very choicest Selected Queens are those denoted above as 'Extra Fine.'

Any Six Queens, 5% off; Ten Queens, 10% off.

Carriage prepaid. Safe arrival guaranteed.

FRANK BENTON, Georgan St. 8, Munich, Germany. (50)



# THE BRITISH BEE JOURNAL

Communications to the Editor to be addressed 'STRANGEWAYS' PRINTING OFFICE, Tower Street, St. Martin's Lane, W.C.'

[No. 142. VOL. XII.]

MARCH 15, 1881.

[PUBLISHED FORTNIGHTLY.]

## Editorial, Notices, &c.

### BRITISH BEE-KEEPERS' ASSOCIATION.

The new Committee of the British Bee-keepers' Association has lost no time in getting to work and subdividing itself into different departments. The labours devolving upon the Committee have increased so much of late years that this step has become absolutely necessary, and the accession of the six new members of Committee will afford most salutary relief in this respect. The sub-committees formed are for: (1) Finance; (2) Examination of Experts; (3) Promotion of County Associations; (4) Exhibitions; (5) the Bligh Competition. The Honey Market sub-committee has not been revived as yet, owing to the discouragement which this project met with at the late General Meeting. There is little doubt, however, that its services will again be required whenever we may have an abundant honey harvest. A sub-committee for the detection of Adulterated Honey has also been spoken of; and we may hear more of this when M. Otto Helmer, the newly appointed analyst, once commences his operations. There seems to be plenty of work in hand, and to be plenty of good men to do it; and we think we may congratulate the electors of the Association in having made an excellent selection from the candidates who offered themselves for their suffrages. At the same time we wish the new Committee every success in carrying out the measures entrusted to them by their fellow-members. The names of those composing the different sub-committees will be found in the report of the last meeting of the Committee on p. 96 of the present number of the *Journal*.

### CIRCULATION OF THE JOURNAL.

The Reports of the several County Associations already received contain valuable information for those interested in the management of County Associations. It is worthy of remark that the more recently established societies are at the head of the list in regard to the number of members. How has this been brought about? We consider that it is mainly attributable to two causes: (1) the employment of an expert who visits the apiaries of the members for the purpose of giving them instruction in the management of their bees; (2) by

the circulation of the *British Bee Journal* amongst the members. Each of these County Associations divides its members into groups of from five to ten members each, according to circumstances. The usefulness of the *Journal* is, however, oftentimes much retarded by the negligence of some of the members to pass it on to the next member who is placed on the order of circulation. This difficulty has, however, been reduced to a minimum in the districts of one or two County Associations by the adoption of the following plan, which we venture to publish for the benefit of other Associations:—  
(1) The names are placed on the order according to residence. Mr. A. receives it first and passes it on to Mr. B., who resides nearer to him than any other member; by this means the *Journal* may oftentimes be delivered by hand and postage saved.  
(2) A manager of each district is appointed who should (if possible) be entered about third on the list of a district where five members are placed. The order of circulation contains a notice to the effect that all complaints in regard to the irregular circulation should be addressed to Mr. —, the manager above named. Should such a complaint come from No. 2, the manager knows at once that No. 1 is the offending party. If the manager has received the *Journal* himself and passed it on to No. 1, and then gets a complaint from No. 5, he knows at once that No. 1 is the transgressor. Where nine or ten members are placed on the list, two managers should be appointed, Nos. 1, 2, 4, and 5, sending their complaints to No. 3; and Nos. 6, 7, 9, and 10, sending their complaints to No. 8. We gladly submit this plan to those who experience the difficulties complained of.

### THE BLIQH COMPETITION.

In our correspondence columns will be found a few further suggestions as to the working of this interesting experiment. The Committee of the B.B.K.A. have selected a sub-committee consisting of the Hon. and Rev. H. Bligh, Messrs. J. M. Hooker, D. Stewart, H. Jonas, and J. N. Bower, who will proceed at once to formulate rules for the guidance of those who purpose to be candidates. It is to be hoped that the rules may be on such a broad basis that candidates from all parts of the United Kingdom may be induced to take a part in it, and that in the competition all the systems of

modern bee-keeping, the Skep, the Bar-frame, the Stewarton, &c., may be represented. On the first occasion the experiment extended from May 20th, 1882, to August 30th, 1883, and we presume the new trial will extend over the same period. The following subscriptions towards the prizes have been promised; and as it is not desirable that the funds of the Association should be appropriated for this purpose, may we request intending subscribers to forward their donations to Mr. Huckle before the 1st of May:—

Hon. and Rev. H. Bligh	... £2	0	0	
Rev. G. Shipton	... ..	2	0	0
Rev. H. R. Peel	... ..	1	1	0
H. V. Edwards	... ..	1	0	0
J. Rodham	... ..	0	2	0

#### COUNTY ASSOCIATIONS.

Reports of several County Associations for the past year are to hand. We give a statement of the number of Members of each Association. The following is the list already received:—

ASSOCIATION.	MEMBERS.	ASSOCIATION.	MEMBERS.
Sussex	301	Hampshire	146
Kent	300	East of Scotland	144
Hertfordshire	295	Leicestershire	127
Buckinghamshire	238	Cardiganshire	121
Norfolk	234	Berkshire	120
Staffordshire	218	Northamptonshire	115
Wiltshire	190	Herefordshire	112
Essex	186	Yorkshire	95
Dorsetshire	177	Oxfordshire	82
Worcestershire	176	Brecon	72
Derbyshire	170	Huntingdonshire	69
Cornwall	166	Somerset	67
Surry	160	Shropshire	52

In order that the volumes of the Reports of the Affiliated Associations may be bound and placed in the hands of the County Secretaries, it is desirable that the following counties should forward their Reports at once, viz., Cheshire, Cambridgeshire, Devonshire, Lancashire, Lincolnshire, Suffolk, and Warwickshire.

Persons desirous of assisting in the formation of County Associations in the undermentioned counties are requested to send in their names and addresses as follows:—Cumberland, Mr. J. Bolton, Fairview, Howard Street, Penrith; Mr. T. E. Highton, Keswick; Mr. Drinkall, 57 Castle Street, Carlisle. Pembroke-shire, Mr. H. A. Hicks, Rock Cottage, St. Thomas's Green, Haverfordwest.

#### LINCOLNSHIRE AGRICULTURAL SOCIETY SHOW AT GRANTHAM.

We have much pleasure in directing the attention of our readers to our advertising columns, where the Great Annual Show of the above-mentioned Society is announced to be held in Grantham in July next, and to the very liberal sums which are offered for prizes in its Bee Department. We have had an opportunity of inspecting the complete Schedule of Prizes, with conditions (which will appear in a subsequent issue), and we consider them of such a character as to offer those induc-

ments as must bring a large competition at this important county gathering. We note that the Society makes no extra charge for space, so that a competitor having paid his entry-fee (which we may mention is small) has no further expenses in that way. The Bee Department is under the management of Mr. R. R. Godfrey, of Grantham, who, doubtless, will bring into action his intelligent experience, so as to make the Show an assured success.

#### MESSRS. EDEY'S METAL ENDS.

These ends require no cutting of frame; the small angular points or spurs cut their way into and obtain a firm grip of bar. They are easily pushed into position by the fingers, and will not drop off. The web being slightly hollow takes a firm bearing surface on outer edges of upright, and is continued across, considerably strengthening the end, and, at the same time, improving the appearance of frames when in position by the metal ends being in a true line. It will be seen by engraving that the end is level with top surface of bar, an essential feature, any space that is left between top of bars and quilt being liable to be filled with propolis, preventing its easy removal and the close fitting of many section-crates.

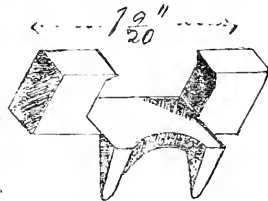

#### BEE FLORA.

We are requested by Mr. R. R. Godfrey to state that the Persian clover seed, also the other seeds named in his Bee-keepers' Floral Packet (see our advertising columns), are specially selected as being desirable Bee-forage for the *season immediately ensuing*.

#### BEE FLOWERS.

In the interesting account Mr. Cowan has recently favoured us with of his visits to various eminent bee-keepers in Switzerland, he incidentally mentions the peculiar effects of two plants, found in the Alps, on bees and honey. In one case it was noticed that bees partaking of the sweets of a plant allied to our Sea Holly, called Eryringium, were so overcome that they gave up work, like the storied lotus-eaters, and were content to dwell in dreamy satisfaction on the bosom of the flower. I have observed that the beautiful blue Eryringium, cultivated in our gardens, is singularly attractive to bees, and the flower-heads are seldom without half-a-dozen humble-bees, that can hardly be displaced, and as many honey-bees. This certainly is a plant to be discountenanced by all bee-keepers who wish that temperance and sobriety should be observed in their apiaries; and in cultivating bee-flowers, or those presumed to

be so, it is as well to know the plants likely to be injurious as those promising to be useful.

The second plant to which injurious properties are attributed is *Astrantia*, like the foregoing belonging to the Umbelliferae. This, although common enough on the Swiss mountains, is comparatively rare in this country; but often brought by travellers and introduced into gardens, it may occasionally help, even in this country, to spoil a sample of honey.

I have often noticed the dark hue of Swiss honey, but I have never found it the worse for being so, and one learns to eat and enjoy honey in the mountains when at home it is rarely tasted.

I am very much disposed to think that we may profitably increase some of our native plants. The common fig-wort\* (*Saxifraga Nivosa*), although producing a small brownish green flower, and therefore as little conspicuous as a flower can be, is nevertheless constantly visited by bees: this I am collecting and growing. Wood sage may be profitably grown when not naturally abundant. Wild thyme is another good bee plant. The willow herbs (*Epilobiums*) are in great favour with bees. Melilot is also valuable, and even that troublesome weed, Charlock, might occupy an unconsidered corner, accessible to bees, when not found in fields. Viper's bugloss (*Echium*) is an excellent and very handsome wild flower. The large flowered kind, *Echium grandiflorum*, was one of the most favoured and frequently visited plants in my collection last year.

One of the most striking plants in my collection of hardy and early blooming species is *Saxifraga lipolata*: it is one of the large-leaved section, and has the great merit of blooming very early in the year; often too early, when it is cut off by spring frost. This season it is in great beauty, and at the time I write (March 8th) has escaped injury by frost. It is so great a favourite with me that I grow it in large quantities, and I am glad to find that it has a recommendation beyond its beauty in being a valuable bee-flower. It seems to possess greater attraction to bees than the crocus blooming abundantly near it—a recognised bee-flower. Doubtless the bees have found within its large and easily accessible blossoms what they require in nectar and pollen, or they would be less assiduous in visiting each flower, and not so disposed to neglect those which have been heretofore so highly esteemed by them.—W. INGRAM, *Deleville*.

#### COUNTY EXPERTS.

In reference to the correspondence in your last issue, containing various suggestions on the examinations of experts, kindly allow me a few words in reply.

The ideas thrown out in your editorial seem to me to go direct to the point. Without doubt there is a demand for a considerable increase in the number of experts, in order to carry on

\* This plant is held in high estimation by American beekeepers, by whom it is known by the name of the 'Simpson Honey Plant,' J. A. Simpson, of Alexis, Illinois, having first directed attention to it.—Ed.

successfully the work of the various County Associations, and, this being the case, it is certainly a matter of the utmost importance that one uniform standard of examination and marks should be adopted by the Central Association, under whose control the entire management should be placed. Perhaps no better model could be taken than that of the Oxford and Cambridge Local Examinations, although the details must, from the nature of the case, differ considerably. In our case, for instance, the counties,—or divisions of the larger ones,—would form a better and more convenient area for carrying on the work than districts. It would be found necessary, I venture to think, that an examiner should be sent from the Central Board to superintend every local examination, since, in order to avoid a system of 'cranning'—of which we are already accused—it would be necessary that the examination papers should be kept strictly private, as at present, and that the examination of the lower grades should be conducted almost entirely *in vacuo*, for which both skill and long practical experience are positive necessities in an examiner.

On this question of cranning 'Platlayer'—with no discourteous intention, I am sure—contrasts an 'intelligent cottager' with 'the gentleman who has subjected himself to the cranning process, and this acquired in a few months what it took the former years to learn.'

Surely this is an entire 'begging of the question.' How does 'Platlayer' know that the 'gentleman' has acquired his knowledge in a few months? My experience certainly goes far to prove the contrary, inasmuch as all those experts, whether ranking as gentlemen or mechanics, who have obtained the certificates of the Association, have enjoyed years of experience,—and that of a far higher order than poor 'Hodge' could ever pretend to,—as evinced both by their fearless, intelligent, quiet, and careful manipulation of living bees, and their accurate replies to questions which could never have been satisfactorily answered by a few months of 'cranning!' only. This assertion, therefore, merely resolves itself into a *petitio principii*. Surely a 'gentleman' may 'win his spurs by sheer perseverance as well as an intelligent cottager.'

Neither do I think with 'learnus' that a Southern expert would find much difficulty in making himself understood by the people of the Cumberland dales, nor they in understanding him. Indeed, such has never been my diligence when perambulating Yorkshire and other Northern Counties. But, after all, if the plan of holding County Examinations be adopted, there is no necessity for altering the plan of examinations, or departing from the three-grade system.

A third-class certificate, under the present régime is most easily within the reach of the 'gardener,' the 'groom,' or the 'intelligent cottager,' and I cannot see what advantage could be gained by reducing the classes to two, as suggested by Mr. Lewis. On the contrary, unless the standard were lowered, many, who now obtain a third-class certificate, would be excluded.

Mr. Lewis says:—'A man who holds an expert's

certificate is naturally expected to be a thoroughly competent bee-master. Why, then, three grades? My answer is, that there are degrees of proficiency. Just as at our Universities candidates for ordinary degrees are placed in four classes, in accordance with the proficiency displayed in classics, mathematics, and other subjects of examination. If, in bee-culture, we find gentlemen, clergymen, or others of University, or liberal education, desirous of obtaining the certificate of the B. B. K. A. as to their proficiency in this science why should not these men, who are able to study their favourite subject in the ancient languages of Greece and Rome,—tracing it back for more than 2000 years to the times of Aristotle, and other ancient authors,—men who are well qualified, moreover, by long pursuit of, and practical experience in, their hobby—why should not such men obtain a higher-class certificate than the simple cottager, 'intelligent' though he be? And I must add, that in all matters appertaining to bee-culture I have ever found the best educated man to be the most skilful, not only in mental, but in manual operations—in neatness, celerity, carefulness, and quietness, in the manipulation and general treatment of the various races of bees. As regards intercourse with the labouring classes my experience in these Eastern Counties differs considerably from that of 'Iardus' in the North. I find very little reserve or timidity on their part, and frequently hold friendly discussions with my cottage friends, answer their well-put queries, and invite them to my own apiary to see in practice what they have heard described in theory; and, in so doing, I rarely find too great a diffidence—never self-conceit, pretentiousness, or display.

In conclusion, let me add that if the Association can see its way to holding examinations for experts at the ensuing Maidstone and Shrewsbury Exhibitions, as well as at the Annual Kensington Show, it seems to me that a step in advance, and in the right direction too, will have been taken.—  
GEORGE RAYNOR, *Horsleigh Rectory, March 6th.*

#### INSTITUTE OF AGRICULTURE.

The programme of the Institute of Agriculture, which has been established for the purpose of advancing technical instruction upon various sections of agricultural practice, and especially for bringing these advantages within the reach of the children of tenant farmers, and others, who are now precluded from such advantages by reason of the expenses which are at present associated with education of this character, has been issued for the coming session. Evening lectures will be delivered in the Lecture Theatre in South Kensington Museum as follows, and will be open to members of the Institute and their friends, on each occasion at eight o'clock:—  
March 17, Ensilage—its influence upon British Agriculture (the hour for delivery may be exceptional, of which notice will be given), Mr. H. Woods—the Prince of Wales will preside over this meeting; March 24, The Physical Structure of England, and its influence upon Agricultural Practice, Mr. Wm. Topley, F.G.S.; March 31, Germination of Seeds, Professor G. T. Bettany, M.A., B.Sc., F.L.S.; April 7, Bees as Friends of the Farmer, Mr. F. Cheshire, F.R.M.S.; April 21, Diseases of our Corn Crops, Mr. Worthington G. Smith, F.L.S.; April

28, Variations in the Quality of Food, Professor H. Tanner, M.R.A.C., F.C.S.; May 5, Science Teachers in the relation to Colonial Life, and Distribution of Certificates of Merit, Professor H. Tanner, M.R.A.C., F.C.S. Technical lectures will be delivered in the same lecture theatre during the ensuing session. The course of instruction on Poultry Management will be given by Mr. Tagemeier; that on Dairy Management by Professor J. P. Sheldon, Mr. Bernard Dyer, and other experts; and that on Bee Management by Mr. F. Cheshire.

#### AMONGST THE SWISS BEE-KEEPERS.

##### No. IX.

The question may be asked, Is the honey-bee indigenous to Switzerland, or has it been imported into that country? To answer this question satisfactorily it is necessary that we refer to the book of Nature, and see if we can there find any trace of the ancestors of our *Apis mellifica*. Those who are geologists know that the earth has been gradually fitted for its present inhabitants, and that it was not always in its present state, and that many thousands of years elapsed before man appeared. Now, the different periods in the world's history are clearly defined, and geology teaches us all that has taken place from the first dawn of life upon our globe to the present day. Although it is impossible to give dates, yet it is possible to give the periods of the appearance of certain plants or animals.

Switzerland is more fortunate than some other countries in this respect, that it has a geological formation called the 'Miocene,' wanting in England, and it is a more recent formation than the 'Eocene,' but both are referred to the Tertiary formation. In this formation are found the fossil remains of plants such as would be suitable as honey-producers, and this for the first time in the world's history, as in formations of an earlier date to the Tertiary, these plants do not occur, and show that the climate of the earth was not suitable for them. As many of these plants depend upon insect agency for fertilising the blossoms it is natural to expect that insects capable of performing these functions would also exist, nor are we disappointed in our expectations, for we find the fossil remains of numerous Hymenoptera also for the first time appearing. The Miocene strata are well represented in Switzerland in different parts, but best of all at Obingen, on the lake of Constance, and many of the fossil plants found there have a great analogy with the flora of the present day. There are about eighty places in Switzerland where Miocene plants have been collected, but nowhere so abundantly as at Obingen, where no less than 465, out of a total of 747 species, have been found. Considering the limited extent of the field of observation, the flora of the Miocene was much richer than that of the present day, and Professor Heer supposes that there must have been at least 3000 flowering plants in the Swiss Miocene district. The quarries where these fossils have been found belong to the communes of Wangen and Schienen, but as these fossils were first made known through the monks of Obingen, the name of that place has been conferred upon them. The Upper Quarry, which is about 700 feet above the Lake of Constance, is the chief source of the fossil plants; and the leaves, the organic matter of which is preserved, are generally of a brownish colour, and stand out in beautiful relief on the white stone.

Now, let us just take a brief glance at the plants of the Miocene which would be likely to be frequented by bees. First are the Salicinea, represented by the present willows, the most abundant species being *Salix carionis* and *Salix Lacatari*. Poplars, of which eight species have been found—there being only four wild

poplars now existing in Switzerland—show that in Miocene times types which are now only found in Asia and America were associated together with those of Europe in Switzerland. A hazel (*Corylus Mac Quarrii*) was widely distributed. Of oaks, thirty-five species have been found, and from the appearance of the leathery leaves the oak-forests must have presented a different appearance from those of the present time. Elders and birches fringed the brooks and rivers, similar to those of the present time; and the laurel (*Laureus princeps*) was most abundant, forming at this time large evergreen forest-trees with thousands of flowers upon them. Of the Composite twenty-one species have been found, of which only the fruits have been preserved, but they leave no room to doubt that a considerable number flourished in the Eningen forests. The common bilberry (*Vaccinium myrtillus*), and also the bog-berry (*V. uliginosum*), and varieties allied to them, have been found, as well as the swallow-worts similar to the American variety (*Lycopus longifolius*), and, probably, formed similar small low bushes, with narrow leaves and white flowers. Umbelliferae, Ranunculaceae, and Cruciferae, are represented by a few fruits and a small-flowered ivy (*Hedera Korymb.*). The tulip-tree (*Liriodendron Procaccinii*) was similar to the American tulip-tree of the present day, which is said to yield honey so abundantly, and which is now the only known living species. Seven species of myrtles have also been found, and a fine Eucalyptus (*E. oceanica*), analogous to the Australian gum-trees. Lime-trees are represented by forms which are now quite foreign to Switzerland, and from the abundance of the leaves, quite a forest of these trees must have existed. Maples also held a very important position in those days, there being no less than twenty Swiss species, described by Professor Hoor in his *Tertiary Flora of Switzerland*, the most important being the three-lobed maple (*Acer trilobatum*) which was one of the principal forest-trees of the Tertiary period. A species of holly is still found in the Swiss woods, but the Miocene period had nine species, and the primitive forms of the cherry, plum, and almond-trees existed, and are represented by the fossil forms of the two genera *Druvus* and *Amygdalus*, of which several species have been found. Nor is the whit-thorn wanting, and, no doubt, this was then, as it is at present, a good honey-yielding plant. Leguminosae in Tertiary times, as at present, formed an order, including a very great number of species—there having been no less than 131 species found. Amongst these the Mimosa, now wanting in Europe, flourished, and in appearance resembled the living *Leontia lupanaria* and *A. dealbata*. They are most abundant, and quantities of both leaves and fruits have been found. Of the Papilionaceae, those found chiefly belong to the exotic groups, and contribute much to impress a southern character to the Swiss Tertiary flora, for instead of being the herbaceous forms of the present day, they were the trees and shrubs of the warmer zones belonging to that family. There is the *Melilotus prostratus* and *Trigonotis Scyfridi*, also a Colutea (Bladder-senna) and *Rhinus Regelii* similar to the common red Robinia (false-acacia) of our gardens. The Cistaceae are represented by no less than thirty-eight species.

Some of the plants alluded to have been found in the Eocene in England, in the London clay at Sheppey, and some leaves in a thin layer of pipe-clay at Alum Bay, in the Isle of Wight, but nowhere in such quantities as in Switzerland. Now, the period I have just been describing is the first in the world's history when such an abundance of honey-yielding plants appears, and it is precisely at this period that the first traces of bees are found. At Eningen, amongst other insects, the Hymenoptera are well represented. Many Hymenoptera live on plants, others saw holes in leaves, and deposit their eggs in these, as the 'leaf-wasps' and 'saw-flies.' 'Wood-wasps' bore into trees, whilst others collect

honey and pollen of flowers, and with these nourish their young, living together often in large societies; and 'saw-wasps,' who live by plunder and murder, dig holes in the earth and into them drag their victims; others, as the Ichneumonidae, too lazy to provide for their young, deposit their eggs in caterpillars, which develop into larva, and devour their victims whilst still living. All these conditions were realised in the Miocene age, and bees and other Hymenoptera are found, all of which doubtless followed the same modes of life as their existing descendants.

Of the wasps found, *Polistes primitiva* belongs to a genus the species of which only constructs small nests suspended from plants or fixed to rocks, and similar nests are now most abundant in Switzerland; and at Berisal, on the Simplan, I have counted as many as sixty of these nests on one rock. Also the common wasp is represented in Tertiary times by *Vespa atavina*. Four species of sand-wasps have been found with habits similar to those of the present day. Bees, however, furnish the largest number of species, there being fourteen. *Xylocopa similis*, a wood bee, which constructed canals in trunks of trees; three species of *Osmia* probably made their nests on sunny banks, where they fed their young on honey and pollen; also a large humble-bee (*Bombus duricus*) forms part of the company. But what is of most interest to us is that a honey-bee (*Apis adumitica*) also existed even at that early period, hummed about the flowers, and without doubt lived in large societies in trunks of trees, built waxen combs, collected honey and pollen, and fed its young as bees do now, for it is so like the living species (*Apis mellifica*) that it can hardly be regarded otherwise than as the ancestor of that species.

Thus we see that at a very early date, viz., that corresponding with the sixth day of the world's creation, described in the first chapter of Genesis, and previous to man's appearance upon the scene, the honey-bee cultivated the world by its presence, and continued through subsequent geological periods to the present day without any change in its habits. From the nature of the plants the climate of that time must have been considerably warmer than at the present day, and bees must have had a longer season of activity. After this, when man appeared in Switzerland, we have no means of ascertaining if the primitive inhabitants who lived in the Swiss like-dwellings cultivated bees, for no traces have been found of hives or appliances, and if they used honey it would be probably got from the trunks of trees. At a still later period, when the Romans overran the country, they probably introduced bee-keeping, which was well known to them, for even to this day there are a large number of hives made of the hollowed trunks of trees, closed at the top and bottom with boards, the cracks being filled up with clay similar to what is described by Virgil in the 'Georgics.' The Romans also introduced their laws regarding property in bees, and these laws have formed the basis for legislation from time to time ever since up to the present time. T. W. COWAN.

## FOUNDMENTS OF BEE-KEEPING.

### THE HIVE AND ITS CONTENTS.

(Continued from p. 78.)

It is most important that the propolis used by the bees in autumn, in making their winter quarters snug, should remain undisturbed as far as possible until warmer spring weather arrives, and can reasonably be expected to continue. The quilts and frames should therefore not be lifted unless absolutely necessary. We must see that the space between the quilt and the roof has sufficient ventilation to prevent mildew. The air, admitted by holes made for this purpose, will carry off any dampness which may accumulate inside. These air-

holes require to be made secure against robbers and other enemies by the use of perforated zinc.

We will now assume that the warmer weather has fairly set in, and that the bee-master has considered it prudent to overhaul his hives. They must be examined carefully, and yet quickly, so as not to risk chilling the brood. It is well to transfer the combs, with the bees on them, from moveable comb-hives to clean ones, and salicylic acid solution should be freely sprayed upon all the appliances of the apiary in use, or put away. Should you have no spare hive into which to transfer your stocks in turn, you must try, by sliding the frames with the bees on them from the spot occupied during the winter, to cleanse and spray the entire interior, especially the floor-board. This finished, you are ready to commence stimulative feeding; and we will proceed next to consider—

#### FEEDING AND FEEDERS.

Feeding in spring is most desirable, as the bees are thereby encouraged, to commence breeding in good earnest earlier than they otherwise would. There is a danger as spring advances of the consumption becoming greater than the available food. For this reason feeding is specially necessary in cases of needy hives. We stimulate our bees by feeding much in the same way as a farmer does his stock with oil-cake or other artificial food, in order to produce the best results at the earliest possible moment. It must not be supposed that the cost and trouble of feeding in spring is thrown away, since feeding brings our hives to their full strength earlier, and a longer season for gathering honey is thus attained. Consequently a larger and more profitable harvest may be expected, the best prices being secured for the early honey.

Syrup for spring-feeding must be much more liquid than that used in autumn. *Modern Bee-keeping* (p. 65) gives directions for making it, the proportions to be used being about three pounds of sugar to a quart of water. Care must be taken to avoid any risk of burning the syrup in making. A little salt, and rather less than a table-spoonful of vinegar, should be added, and the whole should be allowed to boil gently for a couple of minutes. A crystal of citric or tartaric acid can be substituted for vinegar, if desired; and it is very well, as a precaution against foul brood, to add salicylic acid solution in proper quantity.—F. S. S. LATER.

(To be continued.)

## ASSOCIATIONS.

### BRITISH BEE-KEEPERS' ASSOCIATION.

The first meeting of the newly elected Committee for 1884 was held at 105 Jermyn Street, on Wednesday, March 5th. There were present, Rev. E. Bartrum, Rev. F. G. Jenyns, H. Jonas, J. M. Hooker, Rev. F. S. Schater, D. Stewart, Captain Bush, W. Martin, Rev. H. R. Peel, and the Secretary. The chair was occupied by the Baroness Burdett-Coutts, President of the Association. The minutes of the last meeting were read and confirmed. A letter was read from Mr. Otto Helmer, accepting the post of Analyst to the Association. It was resolved in accordance with the wish of the President, 'That the Committee of the B. B. K. A., should in conjunction with the County Associations, consider the best means of establishing a Testimonial Fund to the late Hon. Secretary, and to make the necessary arrangements for the collection and disposal of the Fund.' The Rev. E. Bartrum suggested that the fund should be devoted for giving prizes to artisans and cottagers at various shows throughout the country. The question was discussed at great length; ultimately it was resolved, 'That the fund raised be

devoted as far as possible for the benefit of artisans and cottagers, and that the County Secretaries be communicated with to suggest how this can be best carried out.' The arrangements for the collection and disposal of the fund, to be decided upon at the next Quarterly Meeting to be held on Wednesday, April 16th. At the close of the above business the President expressed her hope that the Testimonial Fund might be a great success and worthy of the great work which Mr. Peel had accomplished. The President having retired, the chair was occupied by the Rev. H. R. Peel.

The following sub-committees were appointed, viz., (1), 'Finance': Rev. E. Bartrum, Captain Campbell, H. Jonas, and the Rev. H. R. Peel. (2), 'Examination of Candidates for Certificates as Experts': Rev. G. Raynor, Hon. and Rev. H. Bligh, Rev. F. G. Jenyns, Rev. E. Bartrum, and T. W. Cowan; this Committee were recommended to take into consideration the best means of arranging for local examinations. (3), 'County Association Business': Rev. H. R. Peel, Rev. F. S. Schater, Rev. F. T. Scott, Captain Bush, and W. Martin. (4), 'Blight Competition': Hon. and Rev. H. Bligh, J. M. Hooker, D. Stewart, H. Jonas, and J. N. Bower. (5), 'Exhibitions': H. Jonas, J. M. Hooker, D. Stewart, T. W. Cowan, Rev. H. R. Peel, and Captain Bush. This Committee were desired to make the necessary arrangements for the publication of a pamphlet on 'Honey as Food and Medicine,' for distribution at the forthcoming International Health Exhibition.

The next Committee Meeting was fixed for Wednesday March 19th, and the next Quarterly Meeting, for Wednesday, April 16th.

### HAMPSHIRE AND ISLE OF WIGHT BEE-KEEPERS' ASSOCIATION.

The Report for 1883 states that the Association was instituted in October 1882, and by 31st December, 1883, 116 Members were enrolled. From the Statement of Accounts, we find that the total receipts from all sources amounted to 184l. 6s. 4d., and the expenditure to 129l. 8s. 11d., leaving a surplus in hand of 54l. 17s. 5d., with which to commence the new year.

The Committee announce that they will be enabled in future to send a bee-master in the spring to those Members requiring it, and who have paid their subscriptions. A nominal fee will, however, have to be made, to prevent unnecessary journeys, not, in any case, to exceed five shillings, to include travelling expenses, &c.; and should the finances warrant it, it is hoped a similar visit may be arranged in the autumn.

The financial details of the various shows organized by the Association have been eminently satisfactory. Taken as a whole, a fair profit has been realised, the Newport, Isle of Wight, and Highcliffe Shows, standing first on the list. The honey exhibition and lectures given at Winchester, on the occasion of the Royal Counties Agricultural Society's Shows, were probably the most important in results as regards the advancement of bee-keeping, some thousands of visitors attending the lectures and demonstrations.

The next great show was that held on Aug. 4th and 6th at Southampton in connexion with the great Summer Show of the Royal Southampton Horticultural Society, and was the show and honey fair of the year. A sum of 23l. 15s., together with the medals and certificates, was given away, and, as a result, drew together the best show of honey held in the County of Hants. The silver medal was carried off by Mr. William Hunt, of South Warnboro', and the bronze medal was awarded to the Rev. Walter E. Medlicott, of Swanmore Vicarage.

In addition to these two important shows, the bee-ten was sent to Bishop's Waltham, to the Swanmore Flower Show; to Botley, for the Botley and Cudridge Show; to East Cowes, I. W. Horticultural Society's

meeting; to Shanklin, for the Flower Show there; to Newport, for the Royal Isle of Wight Agricultural Show; to the Romsey Horse and Poultry Society's Show; and to Highcliffe.

The Highcliffe Show, which terminated the exhibitions for the year, was held, by request of the Marchioness of Waterford, in the beautiful grounds belonging to her ladyship, on the sea-coast, near Christchurch. There was a very fair exhibition of honey and appliances, but, owing to the lack of enterprise, there were not many competitors in the local prize list.

The Report, in alluding to the success of the several shows, states that the services of the volunteer experts cannot be lightly regarded. Prominent among these have been the Rev. W. E. Medlicott, the Rev. J. H. Dixon, Dr. Andrews, F. J. B. Beckford, Esq., and the Hon. Secretary, E. H. Bellairs, Esq. Indeed, the latter attended all but two of the shows, entailing many days and nights of hard and anxious work, and upon each occasion the presence and assistance of Mrs. Bellairs was of extreme advantage to the bee-keeping cause, illustrating, as she did, the suitability of bee-keeping as an industry for women. In mentioning the services to the Hants Beekeepers' Association of Mr. and Mrs. Bellairs, the Committee intimate that it is not to be expected that such efforts can again be made; and they feel that they will under the necessity for supplying adequate assistance by the employment of a paid official at a small salary.

The Committee have been enabled to form the nucleus of a Library which comprises most of the standard works on bee-keeping.

#### CARMARTHENSHIRE BEE-KEEPERS' ASSOCIATION.

The Annual Meeting of the Carmarthenshire Beekeepers' Association was held at the Cawdor Arms Hotel, Llandilo, on Monday, the 25th February. In the absence of the President, Earl Cawdor, the chair was taken by Lieut. Gen. Sir James Hills-Johnes, K.C.B., V.C. There was a fairly good attendance of Members.

Mr. L. Oswald Lewis, hon. sec., read the first Annual Report of the Committee, which stated that the Society was in a very satisfactory condition. The number of members was 121; the total income £67, 10s, 10d., including 4s. 1s. 6d. received in subscriptions and donations. The expenditure, including outstanding liabilities, £27, 0s. 8d., thus exceeding the income by £39, 10s. 10d. This deficiency was more than covered by assets in hand of an useful nature valued at 10l. 11s. 1d. The expenditure included all expenses incidental to the formation of the Society. An offer of the parent Society to provide a lecturer free of charge, to deliver a series of lectures upon bee-keeping in April last, was gratefully accepted. Meetings, which were addressed by Mr. T. B. Blow, and which were largely attended, were arranged for the following places: Llandovery, Llandilo, Llanegwad, Carmarthen, St. Clears, and Llanelli. The opportunity was also taken of engaging Mr. Blow to visit members' apiaries.

The first Annual Exhibition was held on the 5th and 6th September. The collection of hives and appliances brought together was large and very complete. The bee-tent attended the Horticultural Show at Carmarthen on the 2nd August, and the Agricultural Shows at St. Clears and Llandilo on the 13th and 26th September, respectively. Previous to the formation of the Association, bee-driving was a thing almost unheard of in the county. Last autumn scores of stocks were rescued from the 'sulphur-pit' by those who owe to its teachings their knowledge of bee-keeping; and, even among the old-fashioned bee-keepers, there is already a demand for the 'Drestrí fashwn newydd' (*Anglice*, the new-fashioned hives). Funds were required to supply the more pressing wants of the Association, more especially

a complete bee-tent and Welsh Handbook upon Bee-keeping.

The chairman moved the adoption of the report and balance-sheet, which was seconded by Mr. J. Taylor. Several amendments were made in the rules, the most important of which effected the appointment of district secretaries, upon whose exertions it was considered that the progress of the Association must to a great extent depend. Mr. J. Jenkin Jones moved, and Dr. Lloyd, Llandilo, seconded the re-election of Earl Cawdor as President, and Lord Dynevor, Viscount Emlyn, M.P., the Bishop of St. David's, Sir James H. W. Drummond, Bart., Lieut. Gen. Sir James Hills-Johnes, K.C.B., Sir John Jones Jenkins, M.P., W. R. H. Powell, Esq., M.P., and Mrs. Bath, as Vice-Presidents. The following officers were also elected: Treasurer, Mr. John Hughes; Hon. Sec., Mr. L. Oswald Lewis; District Secretaries: Carmarthen, Mr. Walter Spurrill; St. Clears, Mr. John Davies; Llanboidy, Mr. W. Emsall; Talley and Llanegwad, Mr. L. Bowen; Llanon, Rev. W. Jones; Llanegwad, Mr. D. Lewis. Committee: the Rev. John Lloyd, Rev. H. Evans, Messrs. R. B. Carver, J. F. Childs, J. Jenkin Jones, Thomas Jones, W. N. Jones, D. Lewis, W. H. Lloyd, J. Lewis Phillips, D. E. Stephens, and J. Lewis Thomas.

On the motion of Mr. L. Oswald Lewis, seconded by Mr. J. Lewis Phillips, it was resolved that a special fund be opened for donations towards providing the Association with a complete bee-tent. At the drawing the following were the fortunate members: W. Thomas, Hope Inn, a bar-frame hive and super; Mrs. Bath, a sectional super; Oliver Hughes, a that-topped skep; and D. Jones, Talley, a feeder. A cordial vote of thanks to the Chairman, who had incurred a drive of thirty miles to attend, concluded the meeting.

After the meeting a number of members sat down to an excellent dinner provided by Host Hopkins. The chair was again taken by Sir James Hills-Johnes. After the loyal toasts, Mr. L. O. Lewis, hon. sec., read a short paper upon Feeding (bee-feeding, of course). A discussion upon bee-keeping generally then took place, in which most of the members present joined.

#### DEVON AND EXETER BEE-KEEPERS' ASSOCIATION.

The Ninth Annual General Meeting of the Association was held on Friday, the 1st February last, at the Guildhall, Exeter, by the kind permission of the Right Worshipful the Mayor.

The Hon. Secretary the Rev. J. G. Danzani read the Report for the past year, and the financial statement was made by the Rev. J. Dickinson, hon. treasurer.

The President of the Association, W. Horton Ellis, Esq., in moving the adoption of the Report, said it was very disappointing as regarded their financial state, but he thought the cause of the deficit might to a great extent be attributed to the state of the weather at the time these shows were held. He was exceedingly sorry to hear that the show at Exeter was a financial failure. He did not know how to account for that, when it was considered that more than 3000 entered the grounds during the exhibition. There was one very interesting feature in connexion with the show, namely, that it was the first exhibition of living bees ever held in Northemby in connexion with the Horticultural Society; but he hoped that whenever the next show was held it would be under more favourable circumstances. He had made it his duty to issue a circular asking for donations, and he thought it had been very fairly responded to, but still there remained a large deficit; and he would now ask all who were interested in the Association to do what they could to wipe out the debt. There was no question that they started with very low subscriptions, namely, 5s. per annum; and although the

Society would be very happy to take a 5s. subscription, they hoped that all those who had its welfare at heart and could afford to increase their subscription would do so. He had been in communication with gentlemen in India with a view of introducing the Indian bee into England. They all knew that the Indian bee was far superior to the English, and he confidently hoped they would succeed in introducing it. The motion, having been seconded, was put and carried unanimously.

The Mayor moved, 'That the best thanks of the Association be given to the President and to the retiring officers.' Mr. Ford seconded the motion, which was carried.

The Earl of Devon moved, 'That William Horton Ellis, Esq., be elected President for the ensuing year.' He felt that those who took an active part in the promotion of the work of the Society were doing much for the benefit of the poorer classes of the community. It would be very interesting to know how many labourers' families in the different parishes kept bees, and what the result of their labours had been, for he did not think that any returns had ever been made on that point. If that were done he was sure that it would intensify the interest of all those who were interested in bee-keeping, and particularly the working classes. Mr. J. Thacker seconded, and the motion was carried.

The Council of the Association was elected as follows: Rev. J. Bartlett, Rev. E. I. Gregory, Captain Heysham, R.N., Admiral Moorman, and Rev. P. Williams; Mr. W. N. Griffin and Rev. J. G. Dangar, Hon. Secretaries, and Representatives to the British Bee-keepers' Association; Rev. J. Dickinson, Hon. Treasurer; and Capt. Gilbert, R.N., Hon. Expert, for the ensuing year.

A vote of thanks to the Mayor for the use of the Guildhall, and to the President for his services in the chair, was unanimously carried.

#### GLOUCESTERSHIRE BEE-KEEPERS' ASSOCIATION.

I must trouble you to correct an error in your last issue. I offered to assist locally only, and cannot undertake more; what Mr. Cook is willing to do for Fairford, Mr. Zachary for Cirencester, and what others will do for their neighbourhoods, I will do for Cheltenham, thus assisting the Rev. S. E. Bartlett in the general work.—Wm. D. SLADE, *Cheltenham*.

#### WARWICKSHIRE BEE-KEEPERS' ASSOCIATION.

The Annual General Meeting is announced to take place on Friday, April 4th, at 1.30 o'clock punctually, at the Grand Hotel, Birmingham. The Rt. Hon. Lord Leigh has promised to preside.

LECTURE: SURREY BEE-KEEPERS' ASSOCIATION (Croydon Branch).—An address, entitled 'An Hour with Royalty; Indulgence and Work,' was given on Monday, Feb. 25th, in the Lecture Hall of the Young Men's Christian Association, Croydon, by R. J. Hinton, Hon. Sec. of Croydon Branch of the Surrey Bee-keepers' Association. The hall was well filled, and the audience showed great interest in the various matters treated of, frequently giving evidence of appreciation by hearty applause. The speaker was followed throughout with unlagging attention; and although the time stipulated was one hour, and the address lasted about an hour and a half, the hearers evinced a gratifying desire for still further continuation. The title was shown to be no misnomer; and many were the expressions of admiration at the few wonders of insect and flower life that the speaker had time to unfold. The subject was treated partly practically and partly scientifically, and the proceedings closed with a hearty vote of thanks. J. Armfield, Esq., of Cropham Mount, occupied the chair.

## Correspondence.

\* \* \* All Correspondents forwarding Letters for insertion in the Journal, Reports of Associations, Shows, Meetings, Echoes from the Hives, Queries, &c., are requested to direct their communications to 'The Editor of the "British Bee Journal," c/o Messrs. Strangeways & Sons, Tower Street, Upper St. Martin's Lane, W.C.'

#### TESTIMONIAL FUND.

All lovers of the bee-keeping cause will have read with much pleasure the announcement made in your last issue in regard to the proposed Testimonial to the Rev. H. R. Peel. In the hands of the Central Committee, aided by the several County Associations, I feel sure this Testimonial will be made worthy of him whom it is intended to honour, and, in accordance with his wish, will considerably assist to promote the usefulness of the British Bee-keepers' Association. The Committee should, I think, put forth their proposals previous to soliciting subscriptions. If a well-digested scheme, calculated to benefit the bee-keeping cause throughout the country, is published, the subscriptions will be large. Numerous suggestions will, no doubt, be made as to the form the Testimonial should take; I venture to offer the following: 'The fund having been raised, let it be invested say at five per cent, if possible, and the interest given annually to one, two, or three of the county affiliated Associations, to be expended in such a manner as to confer the greatest benefit on artisan and cottage bee-keepers. The counties to be selected each year by ballot, and no county to be entitled to receive this benefit but once during every five years.'—BRITISH BEE.

#### PEEL FUND.

Your Report of the Annual Meeting of the B.B.K.A. has somewhat misrepresented me as 'concurring' in the advisability of a committee being appointed to promote the Peel Fund. Far otherwise than this, I told the members that the Committee already appointed, consisting of the members of Committee of the B.B.K.A., the secretaries of County Associations, and the leading bee-keepers throughout the country, were enthusiastically advancing the movement, and that probably in a few days definite proposals on the subject of the appropriation of the sum subscribed would be placed before the bee-keeping world. Since then, however, at the express wish of the Baroness Burlott-Countts, conveyed in a kind and sympathetic communication on the subject, I have placed the cash and affairs of the Fund at the disposal of the new B.B.K.A. Committee, in order that the proposals may be brought forward distinctly in its name, and I hope the Peel Fund will prosper in their hands.—J. P. JACKSON, 49 Moorfields, Liverpool.

#### BLIGH COMPETITION.

Ever since the gentleman whose name this competition bears offered his handsome donation towards this laudable end, I have taken the greatest possible interest in this matter; although living in a country debared from taking any part in it, according to the rules then published. But I need not vex over not having been eligible for competition, for when so many experts 'fought and ran away, to live to fight some other day,' I need not be very sorry of not having been in the contest. Opinions were invited through the *Journal*, and two competent persons have spoken out in the Feb.



15th issue, viz., Rev. G. Shipton and Rev. G. Rayner; both have given excellent hints so as to make the coming exhibition practical, and not the 'pitting' of a lot of experts against each other: sure, everybody knows that experts can do wonders. But what I believe Mr. Bligh meant was to teach common people what common people could do, if they would only use intelligence and go on improved principles. Now I hold that a competition conducted on the same principles as the last will not advance this end; and, therefore, I would suggest, with all modesty, that so many restrictions should not be put upon competitors, and that the competition should be open to the United Kingdom, and to all systems, and all kinds of hives, and that each competitor should keep his bees on his own premises; and all that should be required of each one would be a solemn declaration that all he made or used was only what was permitted by the rules. I would suggest that the competition commence on May 1st, 1884, and end Sept. 1st, 1885. I would allow every competitor his choice of hive from one at 2s. 6d. to 2l. 10s.; hives, I would not take into consideration at all as regards their value, but would have them reported upon, for the sake of comparing principles, on the 1st of May. I would let each competitor have *only one* hive of bees. Let him pick it from his apiary, and labelled 'Bligh Competition Hive.' I would not allow any queens to be borrowed, bought, or otherwise imported into this hive. If swarms are wanted, let the queen in the hive supply the queens herself, or if the non-swarming system is to be practised (of which so many on paper speak so highly), then that will give parties a chance for to make arrangements for it in good time. Mr. Ditty could then get trying his hand with his long hives, and all extracted honey, while Mr. Simmins and others could get showing a more excellent way in nice little sections. This plan would test both systems and kinds of hives, and would allow all parties to test his favourite idea in an international contest. Even Mr. Pettigrew might enter the competition, as many a time he challenged the bee world to try their wooden boxes against his straw skeps; but as far as I am aware a real contest never took place. This plan is so easy of access that I have no doubt that scores will set a hive apart for the Bligh Competition, and treat it honestly too, giving a full and just account of all he spends on it to produce honey, and what he receives in cash for all he sells of the produce of that hive. I say hive, but it might be six on Sept. 1st, 1885; of course, if he has six, it will be a good item on the profit side at the end of the contest; still, any sugar given to make up for the honey taken away must be taken off the profits. My suggestions may be crude, but, anyhow, they would open a wide door, and increase the usefulness of this very well-meant competition.—PARRY.

### THE BLIGH COMPETITION.

Kindly allow me, if you have space, to add my mite to the number of suggestions that have been made in the *Journal* respecting the above competition. In the first place, I think, in fairness to the poor cottager 'Hodge,' that the production of honey and wax should be the only legitimate source of profit in the competition. If my memory serves me aright, I think when the rev. gentleman first made his proposal to offer the magnificent sum of 10l. for prizes in the first competition, his idea was to benefit the cottager, and to show him how much more profitable his bees would be to him if kept in bar-frame hives and managed on modern principles in comparison to those in straw-skeps, and at the end of the season destroyed in the sulphur-pit; and if such was the idea then, make it so now; place your competitive hives in some cottage bee-keepers' garden, show him, side by side with his own system, the superiority of the modern system, and let the natural produce of the bees, such as

the cottager has always associated with bee-keeping viz., honey and wax, be the sole object of the undertaking; that will do more to popularise modern bee-keeping among cottagers than any amount of profit made by queen-raising, artificial swarming, and various other (to the cottager) new-fangled notions.

I should like to add a suggestion as to the fees. Last time it was 5s. entrance-fee; that, in the present state of bee-culture, I consider too high. I am afraid it will act as a deterrent to many, and tend to circumscribe the affair, making it select, and at the same time neutralise the benefits of the competition. I would suggest that 2s. 6d. be the fee for each entry, and the number of entries be limited to two or three, as the Committee think fit. Also make it an indispensable condition, that any one making more than one entry shall place each competitive hive in different cottagers' gardens, thus spreading and diffusing a practical knowledge of the subject as widely as possible. A reduced fee would prove, I feel sure, an incentive to many to enter the lists that would otherwise stand aloof, and for the advancement of bee-culture it would be far preferable to have forty competitors at 2s. 6d. than twenty at 5s.—WOODRIGH.

### QUEEN-INTRODUCTION.

Under the heading 'Sil-nee gives Consent' Mr. Simmins, in your last issue, complains that 'statements have been circulated to the effect that he expressly prohibits the use of smoke while introducing queens.' I know not whether he means the accusation to apply to myself, but on this supposition I will ask you to allow me a short space in reply.

In his pamphlet entitled *The Simmins' Method of Direct Introduction*, upon my published statement that 'on the method of introducing alien queens opinions vary considerably; but if we act upon the principle of thoroughly *intimidating* the bees, before the union is attempted, we shall not err far from the truth'—Mr. Simmins remarks that this is contrary 'to his experience, except in the case of hives with fixed combs, when the bees have to be driven;' and he goes on to say that by his 'plan of direct introduction to frame-hives, the bees are *disturbed* as little as possible, and a successful union is *invariably* the result.'

Now the chief means used for the 'intimidation' of bees is smoke—as, I think, all will allow; certainly there is no agent, with which we are acquainted that will cause greater 'disturbance' amongst a colony of bees than smoke when freely injected into the hive, and I have always used it freely when introducing queens. In my second edition of *Queen-Introduction*, published by the B. B. K. A., I have certainly stated that Mr. Simmins professes successfully to accomplish all his introductions without smoke; and, after a most careful perusal of his pamphlet, in which the word 'smoke' never *once* occurs, I think I was justified in so stating; but I have nowhere said that he 'prohibits the use of smoke.' When Mr. Simmins asserts that in the case of 'the merest novice, with only ordinary care, in following out his system, a failure is impossible' . . . that 'a queen on a comb, parading unconcernedly among her own bees, would be taken no more notice of than others, when introduced to a strange hive' . . . that 'a queen can be introduced to the desired colony simply by inserting the frame of comb on which she is surrounded by her own bees' . . . that 'instead of the bees being permitted to find out their loss, the exchange is completed before they are aware of the fact'—and a great deal more to the same effect; and while the fullest directions are given for each separate case, so that the *merest novice* may invariably succeed; and yet no mention is made, either by implication or otherwise, of the use of smoke, I maintain that my strictures were fully justified, and, more especially when publishing under the sanction of the

Association, I felt it my duty to warn the inexperienced against a system which appeared to me pregnant with danger, and almost certain failure to the novice, or mere tyro in queen-introduction.

Since, however, Mr. Simmins states that he 'should deem it the height of folly to neglect the important item of smoke,' and that 'he always uses its *soothing* influence,' I am bound to accept his disclaimer; and, although I believe the influence of smoke to be *irritating* and *intimidating*, instead of *soothing*, to the bees, until their honey-sacs are filled, nevertheless, I sincerely hope that when he publishes another edition of his *Method of Direct Introduction* he will take the opportunity of recommending the application of smoke.—GEORGE RAYSON, *Harzeleigh Rectory, March 6th.*

#### HIVE CONSTRUCTION.

While thanking Messrs. Watkins and Lyon for their courteous manner of criticising my hive, as described in your issue of Jan. 15th, I wish to remark on a few of their comments that do not agree with my experience.

Mr. Watkins thinks it 'no wonder I use a draught-preventer when my frames run towards the entrance,' &c. What reason will he give for me doing so when I tell him that hitherto I have used it principally on hives with frames *across* the entrance? It should be evident to all, that when the draught once passes the entrance, it circulates rapidly throughout the chamber, no matter in what position the frames are arranged. My object is to keep it out entirely during the time bees are building-up during treacherous weather. The talk about the frames being the wrong way is all 'no-no-shine.' When Mr. Abbott saw my long hives with frames across the entrance, he told me my frames were the wrong way. In less than two years after we find him describing his 'Combination hive' with the frames placed in the manner he had previously condemned. The only reason for placing them parallel with the front wall in such hives, has been because that style was more suitable to hives of that construction. Nearly all the prominent makers still arrange their nine and ten-frame hives with the frames at right angles to the front wall. After a long and extensive trial of all kinds, I am adopting the present arrangement I have recently described, for this simple, but conclusive reason: single-walled hives, with frames at right angles to the front, give me my earliest stocks, and consequently the greatest profit.

Mr. Lyon objects to the  $\frac{3}{4}$ -inch ends to my bars, saying it is impossible to hold the frames by them. Not only do I find more than enough room for handling them, but have frequently held full combs, 16 inch by 10 inch, in one hand, by a projection of only that length. Even if I had long bars, I should more often take hold of the frame by the middle with one hand. I do not find my fingers 'stuck up' with propolis, neither do I ever crush a bee by doing so. By what method of reasoning Mr. Lyon considers that my frames will not fit in hives of the same construction with even wider rabbets, I am unable to understand; but I *do* know that no two manufacturers will make the internal width of their respective hives exactly the same; and, therefore, a frame with wider regulating shoulders, or one fitting tight at the ends of top bar, for preserving the  $\frac{3}{4}$  inch space, will fit loose in some hives, while in others it will not go down at all, and as with broad shoulders, that is but another fixture, which in all extensive apiaries must become a thing of the past. I have a bee-space round the ends of all my frame bars (how dreadful!), and, therefore, any slight variation in the width of any of my hives is not noticed. A frame of the kind described by me, as I once before stated, because of its independent form, is the only one of which it can be truthfully said that it is universally interchangeable as a Standard. Mr.

Lyon says that the spaces at the end of the dummy will be filled up either with propolis or comb. He says, truly it is  $\frac{1}{2}$  inch narrower than the hive, but that, of course, means a space of only  $\frac{1}{4}$  inch at each end, the same that we all have at the end of our brood-frames. Why, therefore, should the same space at the end of the dummy be filled up? The fact is, that it never has been with me, and I have had them in use for several years. I cannot see that the method of making the frames involves a great deal of unnecessary labour, as Mr. Lyon says. If it is so, what must those think who go to the trouble of making ganging shoulders, or those who cut their frame-ends to accommodate metal ends, which latter must indeed fit tight and true to be of any use at all? The trouble is not taken to hide the nails, but, like Mr. Abbott, I prefer a thick top bar; and as the ends must be gauged down to an even thickness, the sides are tacked on underneath, making the whole much neater and stronger.

I am sure Mr. Lyon makes the suggestion in good faith, but to those who think of making a cover to the pattern illustrated with part Willesden card, I say 'Don't.' The all-wood roof can be made quicker than you can patch up the frame-work to that shape. The trouble of making them exists only in one's imagination. At a time when I knew but little about carpentering, and nothing of mitring, having previously bought all my hives, I made my first ten covers of this shape, from white deal too, and to-day, five years after, there is no sign of the joints opening, nor a crack anywhere about them; and from that day to this, they have not again been painted. I had nothing but the most simple tools to work with; and the novice will find not the least difficulty in making these excellent covers, if he will only follow the directions previously given. Those who have made similar covers, and do not like them, have used wood too thin, or their work must have been bad indeed. All four sides being the same way of the grain, all will shrink or expand evenly; and I believe that every one is aware that (with but one exception, which does not concern us) wood does not shrink from end to end of the grain, and, therefore, how is it possible for the mitred joints to shrink apart, being at the end of the grain? By using sufficient (at least five down each side) two-inch brads, my covers are made as firm as a rock, and continue so, and bear the test of time, and comparison with all other makes.

With regard to Mr. Sadder's *un*courteous, but amusing remarks, I ought to be much obliged to him for offering to help me out of my (?) difficulties; but considering that such exist only in his own imagination, I fail to appreciate his efforts. I am surprised that he has so little confidence in his own powers of manipulation, when he considers that my crates cannot be set on the frame-bars cross-wise without destroying valuable lives. Each narrow crate offers no more surface for crushing bees than does one full-sized crate or rack of any other description, while they are so much lighter that there is less probability of doing so; the slightest pressure with a back-and-forward motion will cause a dense mass of bees to get out of the way, even if they are not first driven down with a puff or two of smoke. Or they can be put on at the middle of the day, when nearly all the working force is abroad. I always had a great objection to the pieces of comb built above the frame-bars, and the bleeding honey every time the crate, or a few sections, were moved; and now, by doing away with the space, I have neither, and can remove my crates with the greatest ease.

Such a slipshod arrangement as Mr. Sadder suggests for the supers will, I am sure, be condemned by all practical bee-keepers, for reasons that it is needless now to give. I am glad Mr. Sadder has such a good opinion of his own hive; I can assure him I have even a better opinion of mine.—SAMUEL SIMMINS, *Rottingdean.*

## SYRIAN BEES.

Since I wrote on above several friends have asked if I had any swarms or stocks for sale (which, of course, I had not), being anxious to try these bees, but not caring to risk the introduction of such valuable queens. After thinking the matter over I came to the conclusion that inexperienced or timid people would go without rather than run the risk. Considering it is on record in the *Journal* that expert bee-keepers have lost six queens before introducing one, and having introduced very many queens, and feeling confident I could safely introduce every one myself, I thought I might help to make these bees popular, and enable all to get them (for undoubtedly they are the bees of the future), if I Syrianised a number of blacks and charged sufficient for them to cover my expenses. The queens will come direct from Mr. Frank Benton; and Sheffield, being in the centre of the country and the railway systems, the cost will be very little. I propose putting a swarm free on rail in May for 42s., and as I shall have to buy the bees, obviously, in many cases, these can be accepted in payment.

Mr. Benton says I can depend on his sending me the queens, and good ones too; so every one will be able to prove for him-self whether or not these bees are fierce or unprofitable. See *B. B. Journal*, p. 127, vol. ix., where the Editor (Mr. C. N. Abbott) gives chapter and verse how he obtained upwards of 20% profit from one hybrid stock of these bees. I don't look on this matter as a trade affair, as I am not aware that any one else besides Mr. Benton is supplying these bees,—no doubt as soon as their value is recognised others will go out to breed them,—but rather the interest of the British bee-keeper, by putting in his hands the most profitable bee.—JOHN HEWITT, *Sheffield*.

## PLANTING FOR BEE FOOD.

The question so often discussed in the *B. B. Journal* as to the best flowers and trees for supplying the bees with food in vicinity of lives, is one of great importance; but I think the number of flowers recommended often tends to defeat the end aimed at, which, to my mind, should be the supplying a good pollen-producing plant in early spring, and a good honey-producing shrub or flower in the autumn. It appears to me to be useless to recommend planting a small piece of garden with any honey-producing flowers in the summer, as the bees, if strong, require a great range of flowers to draw their supplies from. I have found nothing so suitable for early spring as the willow, or palm, producing both honey and pollen in large quantities, and eagerly sought after by the bees. My attention was called to it many years ago by noting that bee-keepers in the vicinity of woods where willows abound had swarms for sale much earlier than their neighbours in less favoured localities. I have planted them for some years, and they are now coming on, furnishing the bees in large quantities what they so much require.—W. T. Buxley, *Kelvedon*.

## GROWING FLOWERS FOR BEES.

Having read from time to time in the *B. B. Journal* the questions and answers as to the flowers for growing for bees, what are recommended and what are not, I beg to state as a bee-keeper, that, with the exception of beds of crocuses, I cannot see the use or advantage of buying the small packets of seeds that are now offered by florists and others in the *Journal*. What good, I ask, in growing a small quantity of Persian clover, or Phacelia, Limnanthes, Mignonette, or Canadian Balsam, except to be taking to the eye, which, in a great many cases, bee-flowers are not. In my idea, it is like one drop of water increasing the size of the ocean.

Now there is an old saying, that 'what is worth doing is worth doing well.' I do not for one moment wish to

deduct from the value of certain flowers for bees, but I consider that the advertisements of packets of seeds from 1d. to 1s., if grown, are of little use indeed. I know that there is another saying, that 'Every little helps'; that is true enough; but if bee-keepers were to grow, say, an acre of phacelia, or mignonette, or Persian clover, in close proximity to their lives, this would be a different thing, and even then the return to repay one for the trouble, expense of seed, and use of ground, would be doubtful.—T. H. BRECKWORTH.

It is not desirable to speak absolutely on the subject of bee-pasturage. The necessity for supplementing natural resources must depend on local conditions. Some localities are highly favoured,—they have the fruit-blossoms in the spring, the clover, &c., in the summer, and heather in the autumn; but all are not so happily situated. The provident bee-keeper will acquaint himself with the pasturage derivable from his surrounding district; and where found necessary, will supplement deficiencies and fill up the gaps between the various seasons. The supply of honey-yielding plants is a clear gain, both to bees and bee-keepers; and therefore we cannot be too grateful to those who, at the expense of much time and trouble, give the public the benefit of their experience and knowledge. Ed.

## DISTRICT ADVISERS.

'Platelayer' has raised a discussion which promises to be very profitable; and, although his words have been handled somewhat roughly by more than one writer, yet one cannot fail to see he really means that bee-keeping should benefit those for whose benefit Bee-keepers' Associations were instituted, *i.e.*, the cottager. Our worthy President of the B.B.K.A., whose name is a household word in every cottage in these realms, has expressed a wish that the County Associations should maintain and increase their sphere of usefulness, a sentiment that must be cherished by every one with a spark of patriotism within him; and 'Platelayer' has pointed out one of the lines on which that usefulness may be extended. As one daily, I may say hourly, thrown into contact with cottage bee-keeping, I may say the great want is some one near at hand to whom they can run freely for advice about their bees, and how to dispose of their honey. On these two points hangs the destiny, in my opinion, of County Associations. Certified experts are most useful people; I can certify to the pleasure with which the spring visit is looked for, and the amount of confidence placed in the advice given to the cottagers; and I fully endorse what has been suggested in your columns as to not lowering the standard of efficiency, and hope some means will be devised for holding examinations in various parts of the kingdom. But it is not probable that there will be sufficient certified experts scattered over the country, for some time at least, to be near at hand for the purpose of helping cottagers with advice, &c.; and, of course, many of them would make it part of their business, and would be obliged to charge a fee, which 'Hodge' is unable to pay.

Your able contemporary, the *Journal of Horticulture*, recently had a very sensible article on 'Gardeners and Bees.' It pointed out in a most lucid way the advantages of young gardeners having a knowledge of bees, showing the probability of their getting a better situation as a consequence, bee-keeping extending so rapidly amongst the gentry. But the advice there given not only applies to gardeners, &c., to enable them to gain a better situation, but to the cottager generally, to help him to pay his rent, &c., and how best to instruct the cottagers has been the thought of more than one 'father of modern bee-keeping'; and the purpose of many a proposition; but the best solution of the difficulty I

have seen yet is what we endeavour to carry out here in Herts, on the proposition of the Rev. F. G. Jomyns. We have at present sixteen members of our Association who have volunteered to give gratuitous advice to the cottagers in their respective neighbourhoods; they are termed 'district advisers,' and amongst their number are two ladies, three clergymen, and the majority of the remainder are, like myself, tradesmen. Of course, I cannot say how far the services of my fifteen colleagues are in requisition, but I hope they are not less so than my own. Possibly, there may be an amount of diffidence in applying to the clergymen, but I must say from my knowledge of these gentlemen there need not be; but I always endeavour to make all feel they are not troubling me by asking for advice and help, and that any expression of gratitude is ample payment. How far my advice has been beneficial you may gather from the fact that one has gained the first prize two years in succession, and three others have gained second prizes at various local garden shows. Sometimes I am asked to act as umpire over a bargain; Smith is leaving the neighbourhood, and Brown will buy his bees. What is a fair value between man and man? More than once I have been asked to take hives of bees into my garden until one about to remove has 'settled down' again. We can help our neighbours in many ways with small cost to ourselves if we have the will. I have written this much to show that this is a real practical means of extending the usefulness of County Associations, and hope there will be a 'district adviser' appointed in every village of my own county during the present year, and that all the other Associations will follow our example, which I believe will do more than all the other agencies combined to teach the cottagers 'our more excellent way.'

As to the sale of honey I am sorry that I have no suggestion to offer. It is a hard matter to persuade cottagers to exhibit, but when they do they invariably sell their honey if put up in decent form. I am speaking now of the local flower shows. I get many applications for honey, far more than I can supply; if I know of any for sale I am only too pleased to recommend the would-be purchaser where to apply, but doubting whether I could find a turnover large enough to make it worth my while has prevented me from making it a branch of my business. What I find is that cottagers, instead of selling all their honey in one lot to some one else to put up and distribute, prefer to make the most they can of as much of it as possible, and then cast about them for help to dispose of the remainder; but I have not a doubt but that the usefulness of our various County Associations would be greatly augmented if cottagers could through them ensure a market for their honey. That our Association may increase in number and usefulness is my apology for penning these lines, as well as the greatest desire of—A HERTS DISTRICT ADVISER.

[The above suggestion is wise, simple, and practical. It would be well if every county was ramified with a network of active and painstaking 'district advisers,' as our Hertfordshire friend recommends. We can conceive that no means could better promote bee-keeping and bring its teachings and its benefits to the door of every cottager.—ED.]

#### REMOVEABLE METAL ENDS.

As my *nom de plume* of 'Dr. Pine' has been mentioned recently in the *Journal* in the course of remarks and correspondence on the subject of metal ends, will you kindly allow me a few words in reply? As to Mr. Green's ends, the first time I saw them was at Kensington in 1882, when I exhibited mine, which are totally different in principle and construction to his. As to the numerous 'improvements' on my invention, I suppose I ought to be flattered at having been the instigator of so many attempts. I should have been glad

if one of these 'improvers' had exercised his own brains a little more and invented something fresh instead of adopting my pattern in its integrity, with the exception of the step backwards of the addition of a piece of metal across the top. This idea having actually occurred to me when perfecting the invention, and been discarded by me on account of the great disadvantage of its preventing the quilts and the section crates lying flush upon the frames, and thus giving rise to great propolization. The 'improver' in question ought, as an expert and a hive-manufacturer, to know this disadvantage. With another 'improvement' I do not care to deal, except to regret that such a crude affair should have been brought out, as it must tend to bring discredit upon 'metal ends' among novices who do not know the evil of giving bees an acute angle all along the hive-side to fill with propolis. Nevertheless, I respect the inventor for not having servilely followed me.—F. LYON.

#### THE SUPPLY OF WATER FOR BEES.

As the time has arrived when the bees will require a plentiful supply of water for the early brood, the sooner some arrangements are made to supply them (where no natural supply such as ditches, ponds, or river, exists), the better; the method I have practised for some years is to procure one, two, or three large red jam-pans, putting them in some quiet place easily accessible, filling them with elm or deal sawdust, and then pouring on as much water as they will hold, leaving the top fairly wet, but not covering with water. To entice the bees to this supply-place a small portion of honey-comb on each pan, and you will find the bees coming in increased quantities to obtain what they require; the pans will want filling up every morning in fine weather. I have seen them so covered with bees, as to require a steady supply from some vessel allowing the water to gradually drop upon it. My attention was directed to this plan by seeing a vast number of bees sucking up the moisture in an old saw-pit. I have tried this plan for some years, and find it answers very well, saving the lives of thousands of bees, which would otherwise be lost at the different pumps in the locality, by being drowned or washed away.—W. T. BRADY, *Kelvedon*.

BEES LECTURE.—The second of a series of lectures on Bee-keeping, on the Humane System, with illustrations, was given at Bilstone, Devon, by the Rev. T. H. Buckworth, rector of the parish, on Thursday evening, February 21st, to an attentive and appreciative audience, in spite of the inclement weather. The Rev. C. S. Clarke, vicar of South Tawton, took the chair. The first lecture, given in December last, was on the History, Anatomy, and Food of the Bees, and their better management in the Straw Skep, with a condemnation of the sulphur pit and its unnecessary cruelty. Lecture the second was given on Bar-frame Hives and Supering, showing their superiority as to the yield of honey and easier management and manipulation. The lecturer's object and intention being to persuade his bee-keeping parishioners, numbering about fifteen, to take every advantage of the great resources of their immediate neighbourhood (second to none he considers in the South and West of England) from the continued succession of immense quantities of gorse, white clover and heath on the borders of Dartmoor, on which his parish is situated. The lecturer also dwelt upon the extra honey harvest that might be gathered by removing stocks from other parts of the country into this locality during the months of August and September when the heather was in bloom. A pleasant evening was spent, much interest being taken in the illustrations, and several applications being made for the loan of bar-frame hives, and for information as to where they might be procured.

'EXCELSIOR' HIVES, OR EVERY COTTAGER AN AMATEUR HIVE-MAKER.

(Continued from page 68.)

In commencing to make the hive, whether from an Assam tea or other box, first strip off any half round binding, which may be on, and draw out or clench up any nails that may be about; select one end for the front, mark a flight-hole in the centre of the bottom 6 in. long and  $\frac{5}{8}$  in. high. Now take the gimlet and bore a hole through one corner of it, which will enable the saw-pad to enter to saw it out—mind you don't saw any nails. If you come to any, bore a fresh hole and start again—there is no necessity to get out the nail—for cutting these flight-holes will be the only occasion the saw-pad will be in use; the flight-holes must not be cut into box bottom, but on a level with it, see Fig. 4.

There is no necessity to cut or reduce the boxes anywhere else, which will now be simply added to; the floor will make the bottom of hive and be amply thick enough, in fact would do  $\frac{1}{2}$  in. thick as well as 2 inches.

Fig. 2 shows the hive made from an Assam tea box.

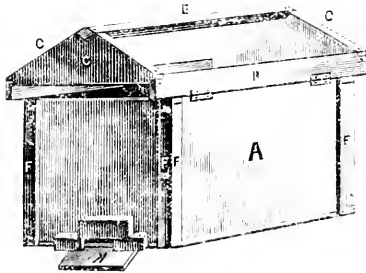

Fig. 2.

with felt cover left off to show construction of roof: A is the box, F F F are strips of thin wood to cover the joints, and make it unrecognisable as having been an old box, and may be left off if preferred. B (two of which will be required) should be  $3\frac{1}{2}$  in. wide and 6 in. longer than box, so as to hang over 3 in. at each end. Let me here remark that it will be far cheaper to buy new timber for all we further want than to knock out of old stuff full of nails, which may spoil the saw and

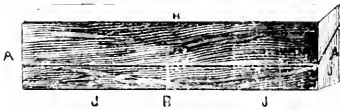

Fig. 3.—Showing how to cut sliding entrance from one piece of stuff without having to fit.

plane; but by all means let your stuff get thoroughly dry before reducing the width in any way so that it will not be able to shrink any more. To cut these sides the best sized stuff to get is 9 in. wide and  $\frac{5}{8}$  in. to  $\frac{3}{4}$  in. thick: you will get two sides and a strip (which will do for the ridge of the roof, see K, Fig. 5), and the same-sized stuff should be got for the ends C C. Fig. 7 will show how to cut these ends, the shaded parts showing the little waste. It will be best to first make a pattern in tin, paper, or wood, to pencil them out by; it will be evident that if more than one hive is wanted; it will be best to use stuff as long as possible. The ridge B may be square, diamond, or oblong: C C should be 1 in. clear from box A, so that a free current of air may pass over the quilt-

ing and keep all dry; and as they hang over 3 in. no wet can drive in, and any stray bees which may be left out when manipulating, can escape and return to hive by the flight-hole. I consider roofs that do not allow ample ventilation and free escape of bees a nuisance, I saw one of them in use last summer, in which the bees from some exciting cause had forced up the quilting and got in the cover from which they could not escape by the wire-covered holes, neither could they return to the hive as the quilt had dropped down again, valve-like, so that the bees had to die of starvation before they were discovered, the loss was serious as they would have made a four-pound swarm. I have also seen the same disaster in two other cases, though not so serious.

The roof is covered with roofing-felt, and must be nailed to B B and C C (not to D), and to make it of everlasting wear and look nice, it may be painted with hot pitch on the top side; put on thinly, then lay on a sheet of brown paper and pass over it a hot smoothing iron, to make the paper stick to pitch (as recommended by Mr. F. Cheshire), when all is cold the roof can be painted like the box with ordinary paint, and will never after be faulty.

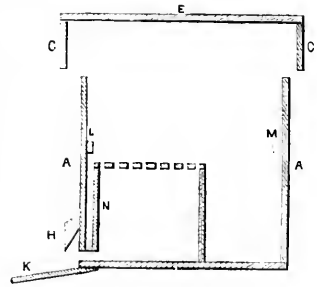

Fig. 4.—Longitudinal Section.

The space between the double walling, see Figs. 4, 5, and 6, should be packed with cork-dust and a strip of lead laid on top loose without being nailed to anything; if cork-dust is not to be obtained, dry fern-leaves, soft hay, straw, or chaff, may be used instead.

Fig. 4 shows the longitudinal or middle section; Fig. 5, the traverse or cross section; and Fig. 6, the ground-plan of hive; the S S's are the corner strips, which may be left off; O O and X is the lining; there is a bridge, Fig. 11, between X and the outside case A, one in. wide, to which X is to be screwed; Fig. 10 shows the inside lining, the best thickness of stuff for which is  $\frac{1}{2}$  in. —In fact, I cannot recommend any other thickness — and for Association-sized frames should be 8 $\frac{1}{2}$  in. wide, when quite dry and planed up, so that if 9-in. stuff is used a narrow strip will have to be cut or planed off; for my part I consider the Association frame too shallow for modern bee-keeping; and if the Syrian or Cyprian races of bees should be universally cultivated, the inconvenience of such a shallow frame would be severely felt. Before extractors and comb-foundation revolutionized bee-keeping, the Langstroth and Woodbury frame enabled us to take off the honey in supers without having to cut the brood-comb; but having used the Woodbury with the extractor, I came to the conclusion that it was

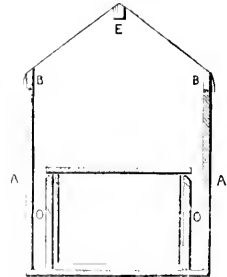

Fig. 5.—Traverse Section.

too shallow, and so I decided on making a frame as deep as practicable, and adopted one 14 in. by 10 $\frac{1}{2}$  in., with a  $\frac{1}{2}$  in. top bar. I have at present seven Woodbury and nine Association frame-hives, which I have run side by side with my own, so that I have been able to make a fair comparison, with the result that I shall never build another Association or Woodbury frame for my own use, and shall use those I have simply as supers on the doubling system. When the question of a Standard frame was decided on, it was expected that it would be the best one for practical bee-culture, the result of direct experiment and comparison by the

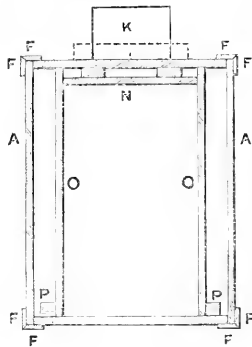

Fig. 6.—The Ground-plan.

it would be the best one for practical bee-culture, the result of direct experiment and comparison by the

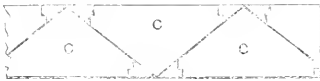

Fig. 7.—Showing how to cut gable ends, c, of roofs of 9-inch stuff: the shaded parts showing the waste.

bee-masters; but instead of which, one the nearest most in use was adopted, though such a veteran bee-master as Mr. Wm. Carr, see *B. B. J.* Vol. ix, page 250, gave his reasons (which I agree with) why it should not be under 10 in. deep. If it is asked me why the Stewarton hive does so well, I should unhesitatingly answer, because it has a very deep brood-nest, and is capable of making the most of its internal heat; then, too, see how a swarm will prosper in a hollow tree, - in a hole some 6 in. across and may be 10 or more feet deep!

Now whatever depth you decide to have your frames there is no necessity to alter the width of 14 inches, so that, if you should at any time find your hive too shallow or too deep, you may take off or add to it as you like; for which purpose I have duly considered, in designing

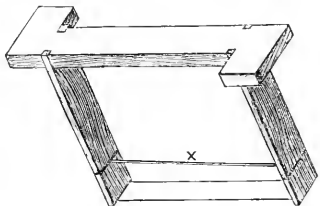

Fig. 8.—Frame.

both hive and frame; in the frame, see Figs. 8 and 9; the sides can be replaced by longer or shorter sides without detaching the comb from the top bar, but each one must please himself as to what depth his frame shall be. If it is my size, his hive-lining must be 10 $\frac{1}{2}$  in. deep; if Association, then 8 $\frac{1}{2}$  in.: the stuff to buy is 11 in. by  $\frac{1}{2}$  in., and 9 in. by  $\frac{1}{2}$  in. respectively. It will do in white deal, but get it well seasoned, dry, and as free from knots as pos-

sible. Cut off square, two pieces for o o, the inside length of the box A; then one piece, exactly 14 $\frac{1}{2}$  in. long for N, and one piece 15 $\frac{1}{2}$  in.; this last piece is in the nature of a stool to act as a guide to nail the strips p r, Fig. 6, by (which should be 1 in. square) to box A. Now take the two long pieces, put them square together, and drive a nail through each end, see Fig. 12; this enables us to get both sides perfectly parallel, which is of so much importance to enable the frames to hang true. I am afraid many first-class (?) hive-makers do not know of this simple plan, as I have noticed hives at shows having one side slightly higher than the other. Now, by means of the straight edge mark and cut off the waste, allowing from  $\frac{1}{8}$  in. to  $\frac{1}{4}$  in. to plane off; now plane the two up, and bevel them as shown, leaving a flat top to each of bare  $\frac{1}{8}$  in. for the frame ends to rest on; when done you may unvail them, and plane them for the insides if you like, and draw a line square across on each 1 in. from the end to enable you to nail them to N quite true; but before doing so first reduce N quite true, cut the flight-hole 6 in. by  $\frac{1}{2}$  in. in the centre of bottom, and then nail together as shown



Fig. 9.—Frame-side.

Fig. 10; but mind you don't get one side slightly twisted; to avoid which, after nailing one side and putting one nail in the other, lay them on a level table, as the sketch is, to chive in the second, when you will be safe. Now make the bridge, Fig. 11, this should be 1 in. thick, at least 2 in. broad, and not less than 9 in. long, the bits s s may be  $\frac{1}{2}$  in. stuff nailed on, or cut out of the solid, and should form a tunnel 6 in. by  $\frac{1}{2}$  in., lay it against N, and by means of the straight edge see that it comes flush with the ends of o o; when all is right, firmly nail it to the case A, exactly flush with the flight-hole already cut. Now put in the lining N and o o, see that the passage in N is flush with the bridge, to which screw N, then screw o o to p r, and your hive is lined; there is no necessity to nail or fasten the lining in any other place, whether sides or bottom, and if at any time you want to disinfect or alter, it can soon be done, and put together again. A space of 1 in. is ample between N and the case A.

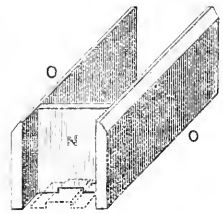

Fig. 10.—Inside Lining.

In Mr. Abbott's 'Copyable' hive (of which this may be considered an improved modification) double-walling in front is not shown. And to give one instance of the disadvantage of single walls, I may remark that I had a stock of blacks in one of



Fig. 11.—The Bridge.

Abbott's Copyables (which I bought) in the fall of last

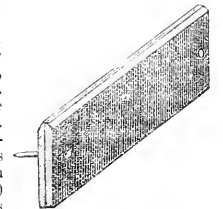

Fig. 12.—Side-board for inside lining: nail together so as to plane them up to true parallelograms.

year, and to which I had introduced a very valuable queen, the outside wall was 2 in. thick, and stooled facing the east in a bleak place. On looking them over in the beginning of December to see if they were likely to want candy (none of which had been given them), I found in the front, *i.e.* between the first comb and hive-wall a thick seam of dead bees packed into empty cells, and others on the top of them, and queen with them also dead. There were four or five seams of live bees behind them, plenty of food and passages from the front comb to the rear, also honey sealed and unsealed in the front; and it was this last fact which caused the loss, for had there been no food in that place there would not have been any bees there; had the bees not been there they would not have been chilled to death, nor would they have been so had the hive only been double-walled; so we live and learn, and in future no more single sides for me, though it was the only one I had bees in.—JOHN HEWITT, *Sheffield*.

(To be continued.)

## Echoes from the Hives.

*Devonshire.*—The winter is passing away favourably, but the weather during January and February has proved changeable; cold wet days have been followed by bright sunshine, so warm at times that one might almost imagine summer had arrived. The total rainfall in January was 4.19 inches; number of wet days, 19; during February there were 21 wet days, with a rainfall of 4.05 inches. In 1883 the rainfall in January was 3.98 inches, and during February 5.68 inches. Numbers who have examined their stocks find brood in most of their colonies. This is always a dull time of the year, but shortly we may hope to have more to report.—WM. N. G., *Hon. Sec. D. & E. B. K. A.*

*North Leicestershire.*—During the four weeks ending to-day (8th inst.) bees have been in full flight on nine days, but on three only of these have they been able to procure pollen, for though the weather was often very bright, the temperature was too low to unclose the crocuses, except for short intervals. Pea-flour, however, has been taken with avidity, especially by those stocks which had been stimulated in good time. In some hives sealed comb has disappeared with wonderful rapidity, and there have been some narrow escapes from starvation in consequence. Most of the stocks are strong for the time of the year, and spring-feeding is now the order of the day. On Sunday last, a bright day, bees were in full flight, although the thermometer stood as low as 40° in the shade. Snowdrops, crocuses, arabis, and primroses, are in full bloom; colts-foot just opening.—E. B.

*Bedfordshire, Coppe.*—Notwithstanding the mild weather bees have done very well this winter. Out of twenty-seven bar-frame hives I have examined this March I have found three dead; one of my own eight, through mice having gnawed the combs and let them down, and two of a neighbour's, one through dysentery and one mice. His hives were packed close together and fencel round with bundles stuffed with straw, and covered over with sacks so that the bees could not get out—a bad plan, in my opinion. Started stimulating yesterday, March 10th; and up to that date have not seen the least particle of brood, which is, I think, remarkable, as we reckon to be done swarming here at the end of May, or, at latest, the middle of June. I may add that I have used a great deal of candy made on Mr. Hewitt's system, but given on top of bars. The mild weather allowing the bees to get water, they have done well on it. The wind has changed, while I am writing, to north-east; should it continue there I fear some sharp weather even now.—A. F.

*Worcestershire, Bromsgrove, Feb. 26th.*—The weather here, as elsewhere, continues mild and open, with a

temperature very often of 50° in the shade. Bees are busy most days, though little for them to get at present, save from the crocuses and snowdrops. They take in pea-flour very fast, and all my hives a fortnight ago contained capped brood and young bees about. I have not uncapped any of the sealed food yet, but am giving them a little food from Mr. Cowan's receipt. I have taken off the candy which I had on during the early months of the winter. Around this district early swarms are prophesied by some of the knowing ones, and which, of course, we all hope may prove correct.—G. H. G.

*South Cornwall, March 7.*—I don't think you have published an 'Echo' from Cornwall for some time, probably because from no part was there any distinct utterance to repeat. Indeed, we could only say 'ditto' to reports from other counties. We have had a mild winter, but a dull and cloudy one, in which our bees had but few days favourable for flights. I hear that some stocks have died through ignorant or careless treatment at the end of last season, which one of our committeemen told us the other day was the worst in his forty years' experience. I examined most of mine a few days ago, and gave a little cake to two, though I am not sure that it was needed by more than one. Seven others were in good case; one or two had pounds of sealed honey in their frames. Skeps are rather light, but safe so far. Happily, the lullinches—those, worst of all the pests we have in our fruit gardens, have spared me more goose-berry buds than for some years previous; these, with currants and raspberries, will, if we get three or four weeks of fine weather, give us more and better nectar than the vaunted bee-plants. I by no means despise these, but, after *Arabis* and *Linanthus*, I have more confidence in general varied sources of supply.—C. R. S.

## Queries and Replies.

QUERY No. 750.—(BAGDADE.) 1. *Removing Hives Ten Miles.*—Wanted to remove two bar-frame hives ten miles; combs built last summer (date); driven bees. Will it be safe if suspended in a van, or on a hand-cart and pushed?—A. The hives and combs will travel safely, if suspended as you say, or even if placed upon a thick bed of straw. See also reply to T. B. G. (2)

2. *Moving Hives Thirty Yards.*—Have been obliged to remove two hives (on account of new buildings being put up where they stood) a distance of thirty yards, in same garden. What can be done to prevent loss, which is going on every few days?—A. Put a board in front of the entrance, and some bushes, or something similar, to obstruct the bees' entrance, and draw their attention to the new position of the hives.

3. *Difficulty in Driving.*—In summer, having driven two or three hives of bees all right, came to one very deep (16 inch or 18 inch), full of comb and bees, but they would not go up at all, but accepted the combs; then they had to be suffocated at last, the farmer getting impatient. Can you account for same?—A. The hive which you found a difficulty to drive was, probably, queenless. It was quite unnecessary to suffocate the bees. We adopt a very summary way with condemned bees, seldom taking the time and trouble to drive them, but cut or break out the combs one at a time, and brush the bees off them back into the skep, which we stand on its own stand during the operation. When all the combs are out, turn the skep right side up and leave for a little time, when all the bees will be found in a cluster. By this method we took last autumn seven stocks in forty-five minutes.

QUERY No. 751.—(JAS. SHEARER.) *Frames across Entrance.*—What are all the favourable points that a hive has by having the frames across the entrance? And what are all the objections to such a hive? In other words, Can it be shown that hives so constructed

are a decided improvement on the hives having the frames with the ends to the door?—*A.* Among the advantages of having the frames across the entrance are, that in winter, by pushing them to the back of the hive, and forming a small entrance in a division-board placed in front of them, such entrance not being opposite the main one, not only does no light enter the chamber in which are the bees, so that they are not tempted out to their destruction, but the wind, however strong, expends itself in the ante-chamber, and in the roof, simply serving to ventilate and dry the quilts, instead of, as must be the case when the frames are end on to the entrance, blowing directly between the combs and chilling the bees and brood, if any. Drifting snow is also intercepted in the same way. Feeding can be carried on at the back without fear of robbing, and sections can be placed there. It is an acknowledged fact that bees store honey in preference at the point farthest from the entrance. As to the disadvantages, the plan has none that are not common to that of having the frames end on to the entrance, unless it be that smoke must be given from the top, or it will not reach the hindermost combs.

QUERY No. 752.—(Rev. J. GEORGE, St. Leonard's).—*Golden Rod.*—Can any of your readers tell me where I can obtain some seeds of the Golden Rod (*Solidago Virgaurea*) which I am anxious to plant for bee-pasture?—*A.* There is not much probability of its being purchased in London, but possibly it might be obtainable at Messrs. Haage and Schmidt, Seedsmen, Erfurt, Germany.

QUERY No. 753.—(J. P.) 1. *Candy and Syrup.*—I cannot get my bees to take syrup for spring stimulation. Would candy cake be equally effective?—*A.* Candy would not stimulate. Unless your bees are very weak in numbers they will certainly take syrup. Have you followed the directions given in *Modern Bee-keeping*, and in *Cowan's Bee-keeper's Guide*?—2. *Foreign Races of Bees.*—Do you consider any of the foreign races of bees superior to the common black species for honey gathering and breeding?—*A.* Yes. We consider the Italians far superior to the black bees in both points; and this we say after twenty years' experience with both races. From our view there is scarcely a dissentient amongst the myriads of American bee-keepers; and all the principal German apiculturists, with Dzierzon at their head, take the same view. The newly introduced Eastern races have not been sufficiently cultivated in this country to enable us at present to give a decided opinion in their case.—3. *Comb Foundation.*—Is comb foundation which has been fixed in sections for two years, and turned perfectly white, injurious or disadvantageous in any way?—*A.* Many prefer new foundation, but in sections we have always found the bees to work as well on old, provided only that it be thin—10 or 11 square feet to the pound. The pale colour is rather an advantage than otherwise.—4. *Time for Supering.*—About what time should stocks be ready for supering in this district?—*A.* By the end of April or the beginning of May,—whenever the hives are full of bees, and honey begins to come in freely.—5. *Re-queening.*—I have two stocks black bees and one pure Ligurian in bar-frame hives. Can I Ligurianise the black from this one hive? and, if so, how would it answer to depose the black queens, and, four days afterwards, cut out all queen-cells and give a frame of Ligurian brood to each hive to raise a queen from?—*A.* Yes, your plan will succeed, but will be more expensive than purchasing imported queens, from the length of time which must elapse before the young queens begin to lay. There is also the risk of their being lost on the wedding trip, and the honey harvest being over before your re-queened stocks are in a condition to gather it. Taking artificial swarms from your black colonies, and placing imported Italian queens at the head of the deprived stocks, is decidedly your safest and best plan. In doing

his the *swarm* should be placed on the old stand, and the old stock moved to a new one, when the Italian queen should be given to it immediately. If the swarm be supplied with comb foundation, in full sheets, it may be supered at once, with sections or otherwise, with a good prospect of heavy return.

QUERY No. 754.—(G. RICHMOND.) *Pollen Masses.*—Will you please tell me what the yellow thing on the head of the enclosed bee is? I found the bee in looking through a bar-frame hive, and shall be much obliged if you will tell me what is the matter with it.—*A.* The bee has evidently visited an orchid house, and has, in attempting to obtain honey from the spur or nectary (?) of some orchid in bloom, ruptured the skin covering the pollen masses, and these have adhered to the front of the head, and been taken away by the bee. These pollen masses are the curious objects which have attracted the attention of our correspondent.

EUCALYPTUS GLOBULUS.—We have received numerous inquiries respecting the strength of the essence of *Eucalyptus globulus*, used by M. Bauverd in curing foul brood, as recorded in issue for Feb. 15. The 'oil' it seems, but not the essence, is procurable in this country. At present the virtues of the Eucalyptus have not been sufficiently tested to enable bee-keepers to state anything with precision regarding them. But as this tree has been extensively cultivated in various parts of the world for drying marshy soils and preventing malarious diseases, there is a great probability of its proving serviceable in arresting and curing foul brood. This affords a fair field for those having the opportunity of testing its efficacy, and we should be pleased if such would make the necessary experiments and report to us thereon.

#### NOTICES TO CORRESPONDENTS & INQUIRERS.

YOUNG HAMB.—*Dummy Boards.*—You had better have two dummies. The entrance in the front one may be about 1 inch long and  $\frac{1}{2}$  inch high, at one end, so as not to be opposite the main entrance. See reply to Jas. Shearer.

A. G. FLEMING.—1. *Quilts.*—If for any reason it be found necessary to scald hives, it would be desirable to renew the quilts. 2. *Salicylic Acid.*—The presence of soda-borax is required to dissolve salicylic in syrup. See *Cowan's Guide Book*.

COLEFORD.—*Moving Bees.*—The hives might be moved on hand-barrows the distance stated. Care should be taken not to shake or jar the combs. A bough of a tree should be placed at the entrance of the hives, to cause them to mark their new location.

TAWIAN.—The piece of comb has come to us sadly crushed.—1. It does not appear to be too old to be utilised. 2. We cannot detect from its appearance any signs of there having been disease in the hive. 3. It is pollen which is to be seen in the cells; it would be of service to the bees in the spring. 4. The distance from centre to centre of frames should be  $1\frac{1}{2}$  inches.

D. WOOD.—*The Anglo-Cyprian Hive.*—Our readers are not disposed that we should open our columns again to a description of this hive. The circumstance of a hive similar to it having been exhibited at Glasgow in 1882 was mentioned by Mr. Cowan in the correspondence that took place at the time the hive was produced. (See Vol. XI. p. 32.)

JAS. SADDLER.—*Removing Candy.*—The advice given to remove candy is based upon the fact that without water to dissolve the sugar contained in it, it is almost useless for food; and at this season bees can hardly bring water into their hives, while they can, and do, get plenty of plenty of pollen, and most stocks suffer from an excess of that substance.

F. MILLS, *Dymock.*—*Sugar.*—Yes, the sample of sugar forwarded will do, but we prefer Refined.



**JAMAICA.**—1. *Fertile Worker.*—Bees will not attempt to raise a queen so long as fertile workers exist in the hive, no matter what eggs you give them. The only plan is to introduce a good laying queen. 2. *Examining Hives.*—In your climate you may examine hives as often as you please, without injury to the bees. 3. *Wax-Moth.*—In a tropical climate the only safeguards against the wax-moth are Italian bees in strong colonies. Cook's *Manual of the Apiary*, an American publication, treats fully of the natural history of bees, and also of the moth. In England we do not fear the latter.

**McK., Loughton.**—1. *Distance Between Rows of Hives.*—The greater space you give the better, but if cramped for room, you may give as little as six or eight feet. 2. *Keeping Syrup.*—If the syrup is properly made it should keep as long as jam at any rate, as long as bee-keepers generally wish it to keep. 3. *Spreading Brood.*—Be very cautious in this matter, not until there is sealed brood in four frames, probably nearly five weeks from commencing to stimulate.

**INSTRUMENTO.**—Your proposed treatment is perfectly correct, and will, with little doubt, be successful.

**J. G., Hatfield.**—You should have moved your hives gradually, only a short distance each day when bees were flying, and should have unsealed the entrances as recommended to Bagdad 21.

**A. P. JULIEN.**—*Queenless Stocks.* We do not think all three hives are queenless. Probably, the one with drone-brood may be so. If you are not expert at finding queens, can you not procure a visit from your county expert? The absence of brood is not a proof of queenlessness at this time of year, although with a prolific queen breeding ought now to be carried on. A queenless hive should be united to its neighbour, unless, being populous, you purchase a queen for it. Procure *Modern Bee-Keeping* or Cowan's *Bee-Keepers' Guide*.

**T. B. G.—1. Mobly Combs.** The combs should be kept in a perfectly dry, warm room. When dry, brush them over with a soft brush. You may then give them to any hive or swarm. It is well to sponge the combs with a solution of salicylic acid before giving them to bees. See Cowan's *Bee-Keepers' Guide*, page 147, for recipe. 2. *Moving Bees by Rail.* A slight frame, fitting the hive, covered with canvas or perforated zinc, should be screwed on the top of the hive to give air. All lateral motion of the frames must be prevented, either by placing strips of wood between the frames, or driving a screw from the outside into the end of each frame; and the hive must be secured to the floor-board. Thus prepared, they will travel securely almost any distance with ordinary care. The hives must not be inverted, nor set upon each other, which would impede ventilation.

**F. J. CHINICK.** *Inserting Comb Foundation.*—You may insert any frame of comb in the brood nest, but it is too early to give foundation. Before spreading brood it is absolutely necessary that all combs be well covered with bees, otherwise chilling of the brood will follow on a change to cold weather. When colonies become populous, say the beginning or middle of next month, when honey is coming in you may insert foundation.

**R. FORD.**—*Feeding.*—Your plan will answer very well. It is simply an application of the principle of Blow's, and many other feeders. Be careful to cover the holes not in use, or you will cause draught through the hive. Stimulation may be equally well carried on, by unsealing a few honey-cells near the bees every five or six days.

**S. H. W.**—Your bees being in the active and healthy condition represented, it would, under the circumstances stated, assist them considerably by the insertion of full foundation sheets about the middle of next month.

**H. S. S., Blackheath.**—In order to make observations as to the flight of bees, marking them by cutting off a portion of their wings would be the reverse of desirable. Painting the thorax white or crimson would be more effective; or if for a temporary purpose dredging them with flour. The American bee-hunter, to note the line of flight of a bee, smears it with honey and attaches a small portion of cotton or wool.

**H. J. SANDS, Harborne.**—*Dysentery.*—The dead bees may have been chilled or starved. If dysentery exists you would find stains like spots of clay, and the dead bees would be smeared, wet, and many burst. As you say nothing about noticing anything of the kind, we trust the disease does not exist.

**S. W., Leamington.** 1. *Old Combs.* Foundation is so cheap that we should not advise you to use old combs infected with moth. Melt them down at once, and do not leave them about for moths to be produced. 2. *Shifting Position.* There is nothing to be gained by shifting the position of the entrances. It is better to prevent the entrance of light by shading. See reply to Jas. Shearer.

**J. C., Southampton, Reading.**—1. *Fertile Worker.* From the irregular distribution of the larvae in the sample of comb forwarded, and from the young drones seen, we should surmise that the hive is queenless, and that a fertile worker reigns in her stead. Fertile workers lay many eggs in the same cells, and these cells have a distended appearance. To get rid of fertile workers, the best method is to introduce a fertilised queen; Mr. House, the American apiculturist, recommends the insertion of one or two queen-cells, just before they are ready to be sealed over; the bees will complete the cells and destroy the fertile worker. 2. *Combs.* Candy made from the recipe of Mr. Sandler and that from *Modern Bee-Keeping* are both good and serviceable, but bee-keepers have their preferences. The difference between the two may be discovered by a comparison of their modes of manufacture.

**F. C., Croyde.** *Feeding Syrup.* The strong syrup used for autumn feeding would be certain to crystallise unless boiled with acid, but the thin syrup for spring feeding may be safely made without boiling.

**F. BOYES.** A fuller description of your very simple device of regulating the position of frames would be welcome.

Several queries have been received too late for Replies this issue.

**FOR FINEST IMPORTED QUEENS, see last Number of British Bee Journal. Address FRANK BERTHOLD, Munich, Germany.**

**BEE-FLOWERS SEED.**—Borage, White Clover, Marjoram (Knotted), Mignonette, Linum catharticum, Bar-tonia, Wallflower, Clarkia Alba, Mustard, Buckwheat; any of the above in 3d. or 6d. packets. Is. order post free. Address H. Y. DUNN, Cringford, Norwich. 1876

**DALLINGHOOD.**

**ANDREW BLAKE**, in tendering his best thanks to all those who have kindly given him their patronage for over Three years, begs to inform them that on account of his other branches of trade, and for convenience of the Hive business, he has made this over to his Son, who has been accustomed to the work, and will carry on the business at Ipswich upon the same principles as before, and he would solicit for his Son the same kind favour which has been given to himself. For the future, Letters for Hives, &c., should be addressed to—

**MR. JAMES BLAKE,**  
BEE-HIVE MANUFACTORY,  
Cemetery Road, Ipswich, Suffolk.

PRICE LIST ON APPLICATION. (64)

# THE BRITISH BEE JOURNAL.

VOL. XI., MAY—DECEMBER, 1883.

Containing 300 pages of Useful and Instructive Information to all Classes of Bee-keepers.  
IT IS ACCOMPANIED WITH A COPIOUS INDEX.

The Contents include Papers on—Hives: Twin, Triple, Stewarton, Observatory, Anglo-Cyprian, Cheap, Single and Double Walled, Skeps—Bees: Blacks, Ligurians, Carniolans, Cyprians, Holy Lands, Syrians, Humble and Wild—Honey and Wax—Feeding, Extracting, Queen-raising and Introducing, Nuclei, Uniting, Bee-farming—Bees-tings and their Remedies—Bee Flowers and their Names—Candy, Syrup, Sugar-cake—Smokers and their Fuel—Lectures—Reviews—Useful Hints from Month to Month—Correspondence on all Apicultural Matters—Queries and Replies—Notices to Correspondents—Reports of Associations, Shows, and Honey Fairs—Bee-culture in Europe, America, India, Australia, &c.—Translations of the best Articles in Continental Bee Periodicals—The Zurich Exhibition—Papers read at Conversaciones—Biographies of Celebrated Bee-Masters—Descriptions of Apiaries—History of County Associations—Reports of the High Competition—Presentation of Testimonial to Mr. Abbott, &c., &c., &c.

Neatly bound in Cloth, price 5s.; post free 5s. 6d. Cloth Covers for binding the Volume, 1s. each.

All the back Numbers of this Volume are still in print.

Vols. 6, 7, 8, 9, 10, and 11, price 5s. each, post free 5s. 6d. may be obtained of J. HUCKLE, KING'S LANGLEY, HERTS.; KENT & Co., PATERNOSTER ROW LONDON; and all Booksellers.

**BEE VEILS** (Improved) with Wire Gauze Fronts, post free for 18 Stamps. Address B. DIXON, Papworth-Everard, St. Ives, Hunts. (79)

**SUPERIOR BEE VEILS.** Wire Gauze Fronts, 1s. each, Three for 2s. 9d. Post free. Address Wm. CRISP, Halstead. 1918

**ILLUSTRATED CATALOGUE** Free anywhere. Pure Foundation, 2s. 6d.; 5 lbs. at 1s. 10d. Best Sections, 4s. 10d. Superior Combination Hive, 24 ins. long, 8s. Prizes awarded to G. STOTHARD, Welwyn, Herts., at Fourteen Shows. 1886

CATALOGUES FREE.

**Simmins' Hives, Crates, & Sections.**  
**'FORTRESS HIVES.'**  
Association 'Standard' Bar-frames, 1s. doz.  
J. H. HOWARD, Holme Apiary, PETERBORO'. 1931

## HEAD QUARTERS

FOR

**Comb Foundation, Sections, &c.**

For PRICE LIST apply to

WILLIAM RAITT, Blairgowrie, N.B.

**CHARLES REDSHAW,**

33 WELFORD ROAD, LEICESTER.

MANUFACTURER OF

**BAR-FRAME HIVES, and Bee-keepers' Appliances**  
OF EVERY DESCRIPTION.

CATALOGUES Post Free on application.

First-class Workmanship; Best seasoned Materials. 1550

## H. M. HART & CO.,

The LONGSTOCK HIVE Manufactory,  
STOCKBRIDGE, HANTS.

**SPECIALITIES:**

HIVES, complete, from 6s. SECTIONS, V-cut, in 6 sizes.  
FOUNDATION, Flat, or natural based.

CLARK'S COLD-BLAST SMOKER. 'Far and away the best Smoker.' 3s., post free.

HART'S SIMPLEX FEEDERS. 'The easiest and best to manage.' 1s. 6d. each, 15s. dozen.

THE 'SWANMORE' SECTION CRATE. 'The most perfect Crate made.' (60)

The Trade supplied. Price List on application.

## WANTED

BEE-KEEPERS before ordering Hives and Appliances to send for ILLUSTRATED CATALOGUE to

**F. COTTMAN,**

15 Market Place, Olney, Bucks.

## PURE FOUNDATION.

**STOCK FOUNDATION** of Gemine Bees' Wax, made on ROOF'S CELEBRATED MACHINES, in Sheets about 13 in. by 7½, some Seven Sheets per lb., price 2s. per lb., 5 lbs. 1s. 10d. SUPER FOUNDATION, 2s. 9d. per lb. (about Twelve Sheets). Carefully boxed free.

SAMPLES GRATIS and CATALOGUES FREE.

**G. STOTHARD, WELWYN, HERTS.**

First Class Export English Bee-keepers' Association. 1915

## CURRENT PRICES

**BERNARDO MAZZOLENI,**

Apiary, in CAMORINO, CANTO TESSIN,  
ITALIAN SWITZERLAND.

**FERTILE QUEENS.** Pure Italian Breed, with a few Bees as companions:—  
March, April, May, June, July, August, Sep. and Oct.  
9 francs. 8 7 6 5 4 50 3 50

Orders carefully attended to. Safe arrival guaranteed.

Packing, and Fuel for transport, included in above charges. Transport charges rest with Purchaser.

All Orders for the Continent to be paid in advance by P.O.O.

**BERNARDO MAZZOLENI, Apiculteur (Bee-keeper),**

A CAMORINO, près BELLINZONA, SWITZERLAND.

## BEE HIVES and APPLIANCES

Of the best quality, at the lowest possible price, to be obtained from

**JOHN LEAKE, JUN.**

BEACON STREET, LICHFIELD.

COTTAGERS' HIVE, made of 1-inch best Pine, planed outside, contains 9 Standard Frames and Dummy, resting on Tin Runners, suitable for Bee-Shed. Price 4s.

ABBOTT'S HONEY EXTRACTOR, best make, 9s. 6d.

LINGHAM SMOKER, neatly and strongly made, 3s. 6d.

Other Appliances at an equally low rate. 5 per cent. discount off all Orders up to April 1st.

Send Card for PRICE LIST to

**J. LEAKE, Jun., Beacon Street, Lichfield. 1883**

# THE BRITISH BEE JOURNAL

Communications to the Editor to be addressed 'STRANGWAYS' PRINTING OFFICE, Tower Street, St. Martin's Lane, W.C.'

[No. 143. VOL. XII.]

APRIL 1, 1884.

[PUBLISHED FORTNIGHTLY.]

## Editorial, Notices, &c.

### APRIL.

The Committee of the British Bee-keepers' Association are facing the tasks set before them with a promptness and assiduity which the Committees of County Associations will do well to imitate. Since the General Meeting of the Association on the 20th of February, the Committee has met on the 5th and 19th of March, whilst the sub-committees have been holding separate meetings of their own to discuss the different subjects entrusted to them, and to prepare them for the consideration of the larger body. We understand that it may be found necessary for the Committee to hold another meeting before the quarterly meeting on April 16th to receive the reports of the sub-committees, and take such action upon them as may be necessary. This is as it should be, and shows that the Central body are alive to the importance of a 'stitch in time.' We hope that the county committees will be equally as active. Nothing keeps an Association alive like meetings of its members. A great advance was made last year by many Associations in dividing the counties into districts, and placing a district secretary at the head of each. It will be a still further advance this year if these district secretaries will call at least quarterly meetings of the members residing in their districts, and endeavour to interest them in what is going on at head-quarters. There need be no lack of topics for discussion. Each district should see a report of the tour which the county expert has made in that neighbourhood, and understand what the expert thinks of its manner of bee-keeping. The rules and regulations for the Bligh Competition should be explained at these meetings, and competitors should be invited to enter the lists. Then again, the question as to the examination of candidates for certificates of the B. B. K. A. affords an abundant topic for discussion. District secretaries should make their constituents acquainted with all these matters, and elicit their opinions on them. By so doing they would make the work of the county secretary-in-chief a much more easy and satisfactory one. To show that such meetings are not out of the range of possibility we would call attention to the agenda of a district meeting called for March

29th, the second which has been held with good effect since the commencement of the year:—

#### BUCKINGHAMSHIRE BEE-KEEPERS' ASSOCIATION.

You are requested to attend a meeting of members residing in the Buckingham district at the Town Hall, Buckingham, at 3 p.m. on Saturday, March 29th, 1884.

#### AGENDA.

1. Secretary's report on district business.
2. Mr. Baldwin's report of tour in Buckingham district to be read.
3. Prize-list for Buckingham Horticultural Show to be laid before the meeting.
4. Rules of the Bligh Competition to be explained to members, and competitors invited to enter.
5. Circulation of the *British Bee Journal*.
6. Enlistment of new members.

W. STURDY, Hon. District Sec.  
Thornton, Stony Stratford.

#### BLIGH COMPETITION.

The Sub-committee appointed for the purpose of revising and carrying into effect the Rules for the second Bligh Competition have lost no time in the performance of their duties, and we are pleased to be able to present them to the bee-keeping world.

It will greatly encourage the Sub-committee by further subscriptions being forwarded as quickly as possible. They have offered 2*l.* in prizes, and as yet only 8*l.* have been subscribed.

Subscriptions, or promises of subscriptions, should be forwarded to Mr. Huckle, King's Langley, Secretary to the B. B. K. A.; and as time presses, may we quote the Latin proverb, '*Bis dat qui cito dat!*'

#### RULES FOR THE COMPETITION, COMMENCING MAY 20th, 1884.

1. The object of this competition is to show the relative merits of different systems of bee-keeping, and to prove to the cottager that bee-keeping, if conducted on economical principles, is highly remunerative to bee-keepers.

2. The competition shall be open to members of the B. B. K. A., and of affiliated County Associations. Competitors are limited to one entry for each system, namely, one for movable bar-frames of any form, one for Stewarton, and one for straw skep or other hive. They may enter for either one, two, or three systems on payment of a fee of 5*s.* for each entry; but the system adopted must be adhered to throughout the competition.

3. Prizes of 6*l.*, 5*l.*, 4*l.*, 3*l.*, 2*l.*, 1*l.*, will be awarded in order of merit to the competitors who shall derive the greatest profits from one swarm of bees at the outset, which may be increased to any extent by natural or artificial swarming, kept on either of the above systems.

The total outlay for bees, hives (which must not have been used before), syrup, and all other requisites must not exceed the sum of 2*l.* for each entry, until a profit has been made by the sale of honey or of a swarm, and nothing is to be used in the apiary until it has been paid for. The competition shall commence on or after the 20th of May, 1884, and continue until August 31st, 1885.

4. The apiary shall not be established in the competitor's own garden, or in that of his servant or master, but in a position approved by the Secretary of the B.B.K.A., or of the Comity Association, or his nominee, where the bee-keepers of the neighbourhood can have access during examination or manipulation.

5. The competitors shall keep at the house of the owner or occupier of the garden a separate diary for each system in competition, in which each examination, manipulation, or transaction connected with that system, the time occupied at each visit, and every item of expenditure and receipt, shall be entered up to the date of each visit. A copy of each diary shall be forwarded every two months to the Secretary appointed. The diaries to become the property of the B. B. K. A. at the close of the competition.

6. The hive to be stocked with a swarm of bees, to be weighed and valued at 1*s.* per pound. Comb-foundation (which has not previously been partly worked out by bees) may be used at any time during the competition, and shall be charged 3*s.* per pound for thin, and 2*s.* 6*d.* per pound for thick. No brood or natural comb to be introduced at any time into the apiary, and no bees to be added after the commencement. Queens may be introduced at any period of the competition, and shall be charged 3*s.* each. Vouchers must be produced for all purchases made throughout the competition. Competitors will only be credited for sales of honey, wax, or swarms. No sales of queens, brood, or empty combs, will be allowed. All honey in virgin comb will be credited at 1*s.* 6*d.* per pound; extracted or run honey at 1*s.* 1*d.* per pound; and wax at 1*s.* 6*d.* per pound. Swarms sold shall be weighed, and credited at 4*s.* per pound.

7. Where a competitor makes his own hives, supers, or other requisites, the same shall be valued by the Secretary or his nominee.

8. The Secretary or his nominee may visit the competing apiary at any reasonable time. The record of such visits, together with any remarks which it may be advisable to make, to be entered in the diary, which shall always be accessible for the purpose.

9. The competitor shall certify that throughout the competition he has fulfilled all the conditions imposed by these rules, and that all his entries in the diary are true.

10. At the close of the competition a complete inventory of the 'plant,' number of frames, amount of brood, honey, comb, bees, &c., remaining in each system of the apiary, with a statement of their condition, shall be entered in the diary, and certified by the Secretary or his nominee, and his estimate of their value attached.

11. Any attempt at fraud, or any departure from the Rules, will be punished by disqualification.

12. The prizes shall be awarded by three Judges appointed by the B. B. K. A. Committee, and their decision shall be final.

13. All entries must be made and entry fees paid to Mr. J. Huckle, Secretary of the B. B. K. A., King's Langley, Herts, on or before May 1st, 1884.

management of this department have been placed in the hands of the British Bee-keepers' Association.

The Committee of the B. B. K. A. are anxious to arrange for a full and comprehensive display of honey and the several appliances used in its production, as will be fully illustrative of the bee-keeping industry throughout the United Kingdom. To enable the Committee of the B. B. K. A. to make the requisite arrangements for such an exhibition, they invite exhibits under the following heads:—  
1. Hives of bees at work. 2. A show of pure honey. 3. Specimens of the most approved hives and appliances as used in modern bee-keeping. 4. Objects illustrative of the natural history of the honey-bee and its kindred varieties, also of bee-flora. 5. The means of detecting adulterated or spurious honey, with analysis of impure or manufactured honey, now sold in the markets. 6. The beverages in which honey forms an important constituent with the recipes for making them.

Copies of the Rules and Regulations, and other information, may be obtained upon application to the Secretary, J. Huckle, King's Langley, Herts.

#### CARNIOLAN BEES.

Since our last issue we have received a number of inquiries respecting Carniolan bees, with a request that some observations should be made with respect to their qualities.

The native home of these bees is in Carniola, a province in South Illyria, in the Empire of Austria. The district is noted for its abundance of honey and bees-wax.

Mr. Edouard Cori, of Brtix, Bohemia, devoted many years of his life to the discovery of those races of bees whose introduction to other countries would prove of direct benefit from their possession of those qualities in which the native bees were more or less deficient. It is to Mr. Cori we are indebted for having drawn the attention of the bee-keepers of Europe to the excellencies of the Carniolan or the Ukraine bee.

The Carniolan bee is not considered a separate race, but rather a variety of the German bee. It has, since Mr. Cori's time, been largely introduced into Germany, chiefly on account of its gentle disposition and its great docility; as even when excited it is less fierce than any other kind of bee. Its failing is its propensity to swarm; and that it does not lay by much honey, and at the fall of the year stocks of these bees seldom have a sufficiency of stores to carry them through the winter. Dzierzon says: 'He who is desirous of increasing the number of his stocks largely will find the Carniolan bees answer his purpose, although he may often be obliged to assist by feeding them; but he who chiefly aims at the largest return of honey will give the Italian bees the preference.'

The Carniolan bee has been introduced with much benefit to France, to America, and to this country. In the year 1874 two stocks of these bees were for the first time exhibited in Paris, at the Exhibition of Useful and Noxious Insects. They

#### INTERNATIONAL HEALTH EXHIBITION.

The Executive Council of the Food Department have resolved to apportion a limited space for an exhibition of honey and the several appliances used in its production. The entire arrangement and

were pronounced to be as pleasing to the eye as the Ligurian bees which were exhibited at the same time. In the year 1877 a swarm of Carniolan bees were sent by Herr von Langer, of Pogowitz, near Rudolphswerth, to a gentleman residing at Rochester, United States. The freight and carriage proved a heavy item in the outlay, amounting to fifteen dollars; but the purchaser said that 'he would not part with his bargain for twice that money.'

We are indebted to the Rev. W. C. Cotton, author of *My Bee-book*, for the introduction of this bee into England. When on the Continent about twelve years ago, he purchased a swarm of Carniolan bees, and on his return to England he consigned them to the care of Mr. Alfred Neighbour, in whose apiary at West Hampstead they flourished and multiplied.

Great difficulty is experienced in keeping the Carniolan bee pure from its resemblance to the common black bee, which renders it difficult to distinguish a hybrid of the two.

From the conjoint opinion of all those who have kept Carniolan bees, we gather that they are great favourites, from their gentle nature and the ease with which they can be manipulated without smoke. Mr. Frank Benton, who has studied Carniolan bees in their natural habitat in Austria, says, 'They are so gentle as to cast the gentleness of the gentlest Italians all into the shade.' An esteemed correspondent says:—

'I can say a good deal for Carniolans. They are good breeders and good honey-gatherers. They are very docile as a rule. When they have the swarming fever on they raise quite a lot of queens. After-swarms have issued three or four or more days. I have had from twelve to twenty queens ready to hatch out at one time. My saying that the Carniolans are docile does not mean that they do not sting at all, for I have a lively recollection of their stinging qualities on one occasion when I did not smoke them enough.'

Mr. Marshall, the manager of Mr. Neighbour's apiary at Buncfield, Hemel Hempstead, says:—

'Respecting the quality of Carniolan bees, I must say I prefer them to Ligurians: they are hardier, and therefore more suitable to our changeable climate. They breed up as quick, are very quiet, and a practised bee-keeper can handle them without smoke or veil, and he very rarely gets a sting. Some of our bee-masters give them the character of being very much given to swarming, but I have not found them more disposed than Ligurians or blacks in that respect. If you want a business bee, get a good English queen mated with a Carniolan drone, the combination of the two races makes a real useful bee: they are the silver bees, as the Ligurians are called the golden bees.'

For further observations on the markings and characteristics of Carniolan bees, see reply to Query No. 758 (2), p. 123.

#### THE CULTIVATION OF BEE FLOWERS.

I hope no one will be influenced to discontinue sowing seeds and planting flowers for bees by the remarks of 'T. H. Buckworth,' who takes a very narrow and mistaken view of the question, betraying a want of knowledge of the value and re-

sources of the garden flora applicable to the support of bees. I am on the lias clay formation, and the soil is not one naturally to encourage an early appearance of wild flowers. Excepting pollen from a few far-off willows and elms there is nothing for the bees this fine weather has stimulated into unwonted activity to pasture on; but turning to the garden the case is very different. In a little garden near my house, 24 yards by 18, I have crocus, saxifrage, wallflower, *Arabis*, *Aubrietia*, in bloom, and these flowers are visited every fine day by bees. In a garden half-a-mile distant, all these plants are more extensively grown, and the masses of spring heather (*Erica carnea*) have an especial attraction to bees; this and early Anemones, *A. blanda*, Cardamine, Scillas, employ all the working bees of my own and my neighbours' hives; and I have the daily satisfaction of seeing the busy insects returning to the hives laden with the sweets of these garden flowers, and not hanging about their homes like mendicants waiting for their dole of syrup. I value our native flora wherever it exists; but increasing our number of bees we must subsidise if we would be successful with garden flowers, and above all provide a supply for early spring, which anticipates the appearance of wild flowers. The palm-willow affords pollen, but little of wax-honey, and its duration is short. What the great majority of bee-keepers want is something for the present season, and willows require years to reach the maturity to make them valuable.

I presume Mr. Buckworth disputes the value of *Linanthus*, though bees themselves have so strongly decided in its favour. And there is another point Mr. B. has overlooked; in unsettled weather bees cannot expose themselves to the risk they incur in long journeys, and home flowers then are of inestimable value.—W. INGRAM, *Belvoir*.

#### GLOUCESTERSHIRE BEE KEEPERS' ASSOCIATION.

We are glad to announce the formation of an Association for this county, the hon. secretary being William Zachary, Esq., of Cirencester.

'HUMBLE BEES!—WANTED FOR NEW ZEALAND.'—By an oversight, an advertisement, thus headed, was inserted in our issue for March 15. We are afraid that this has been a source of trouble and disappointment to Mr. Baldwin and some of our readers. We much regret this, and beg that no more 'Queen Humble Bees' be forwarded to Mr. Baldwin.

#### USEFUL HINTS.

The continued favourable weather will have had the effect of not only bringing bees into a forward state for the time of year, but also unduly exciting the desires of ardent and inexperienced bee-keepers to be transferring, artificially swarming, and doing all sorts of things to their bees, which will almost certainly mean ultimate ruin. The season, although so early, is not yet sufficiently

advanced to take liberties, and the successful bee-keeper is he who waits.

Now is the time to consider and decide upon a plan of operations for the season. Do we wish to obtain as large a harvest as possible? If so, shall we go in for sections or extracted honey? or do we wish to build up a large apiary from a few stocks? In all cases the road lies the same way at first: get your stocks strong, and keep them so. Weak stocks are worse than useless. Inexperienced bee-keepers in their eagerness to have ten or twenty stocks divide and subdivide until they have a lot of weak stocks which can only die out in the ensuing winter. One strong stock may give a good return, while twenty weak ones will give none. By careful stimulative feeding and judicious spreading of the brood stocks may be built up by the end of this month to be strong enough to swarm artificially, or to raise queens for requeening, or for supering, or doubling if extracted honey is desired. Always supposing the weather is favourable.

**OVERHAULING OF STOCKS.**—This should be done at once, choosing a fine warm day for the operation, and the hives thoroughly cleaned and put in order for the season.

**QUEENLESS STOCKS.**—If, on examination, a stock is found with no eggs or brood, and the queen cannot be seen, it may be set down as queenless, and should be united to another stock. Every day's delay only reduces the population, which if headed by a good queen would be working for the common welfare. Unite to a hive next to it if possible; but, if necessary, boldly unite to any one you select, making the exit from the hive a little difficult, so as to call the attention of the strangers to their new abode, and disregard the slight loss of life arising from flying back to the old stand.

**OLD QUEENS.**—These should be replaced by young ones, to be obtained hereafter from hives which have swarmed. A last year's swarm contains an old queen unless it had thrown a virgin swarm when that will have the old queen. A stock which did not swarm last year also has an old queen. If the weather continues as open and mild as it has been, towards the end of April many stocks will contain drones and be preparing for swarming. When that is the case will be the time to arrange for requeening other stocks. Details are to be found in *Modern Bee-keeping*, and in Mr. Cowan's book.

**SWARMS.**—Be prepared to receive these welcome visitors, and have their houses ready and furnished for them. The hives for the reception of swarms should be furnished at first with only three or four frames filled with foundation and closed up with a division-board. All swarms should be fed pretty liberally for a few days until they have built out the foundation. The foundation must be securely fixed into the frames. The best means is by a saw-cut along the centre of the top bar. This can easily be held open by inserting a screw-driver and turning it edgewise while inserting the sheet; and if the latter has a notch cut in the upper edge, to clear the screw-driver, no difficulty will be found in getting it into its place. Care should be taken that the sheet comes quite through to the top surface of the top bar, and that the two sides of the bar are firmly nailed or screwed together, otherwise a most convenient harbour is afforded to the larvæ of wax-moth in a place where the

bees cannot get to dislodge them. The sheet of foundation should clear the side and bottom bars by a quarter of an inch to allow for expansion by the heat of the bees.

**SUPERING.**—Where stocks are very strong and the fruit-blossoms are opening, as is very generally the case even now in the south, supers may be put on, to secure an early harvest. One reason why bees will sometimes refuse to enter supers is their coldness; therefore, be careful to cover up very warmly, and, above all things, to prevent draught. Unless the crates or sections fit all over the frames, cover the vacant spaces with carpet and boards upon it. If the frames have no shoulders, but only the pins or staples of which some writers are so fond, special care is required to avoid loss of heat. Sections in frames at the rear or side of the brood-nest will often be entered when those on the top are neglected. The same caution as to retaining the best applies in this case. The sections should be furnished with the thin foundation specially made for the purpose. The thick kind which is used for stock hives is not so suitable, as the midrib is left thick and is unpleasant when the comb is eaten. If you have any clean drone-comb from outside combs of skeps use it instead of foundation. Be sure it is put right way up.

**ARTIFICIAL SWARMING.**—In ordinary years we should hesitate to mention this operation in our Hints for April; but in the extraordinary season we are now experiencing, we may hope that by the end of the month it may be safely undertaken. At the same time no one can write in March of what may happen in April; and we may find ourselves plunged into winter. From bar-frame hives it is the simplest operation. On a fine day when many bees are abroad open the selected hive, find the queen, and place her and the comb on which she is with two others in another hive, and stand it in the place of the old stock which must be removed to some distance away. Add two frames filled with foundation and close up with a division-board. The flying bees will, with those adhering to the combs, form the swarm. This operation should not be attempted until the stock has eight or nine frames full of brood. If there should seem any fear of unduly weakening the stock, the stock may be left on its own stand and the new hive placed upon the stand of a second stock so that one provides the combs and queen, and the other the flying bees.

**SKEPS.**—Lift them off the floor-boards, turn up and rub off all chips of comb and traces of moth and clean the floor-boards.

**SUPERING SKEPS.**—Prepare as advised for feeding in 'Hints' for February, p. 29.

**ARTIFICIAL SWARMING FROM SKEPS.**—This must, of course, be done by driving, and here the 'three out of two' plan is a good one. Drive all the bees out of No. 1, place the new hive with the bees on the old stand, remove the old hive containing the combs to the stand of No. 2, and place No. 2 on a fresh stand. Thus No. 1 will furnish the bees, and the flying bees from No. 2 will take care of the brood in the old No. 1, and raise queen-cells. Feed the new swarm until the combs are built.

**HIVES AND OTHER APPLIANCES.**—These should have been obtained before; but if not, order at once, and be prepared for some delay in obtaining them.

**MAKESHIFT HIVES.**—If from your own delay you should expect swarms before you have hives in which to live them, get two boards, cut exactly 14½ inches long by 9 inches wide, and two other boards 8½ inches wide and of any length, nail these outside the 14½ inch ones and a box is made ready for the reception of frames and a swarm. It can be stood temporarily on another board and covered temporarily with anything waterproof until such time as you can get a proper hive, when the frames may be lifted into it.

## BEE-KEEPERS AT HOME.

NO. VI.—THE REV. H. R. PEEL, AT THORNTON HALL,  
IN BUCKINGHAMSHIRE.

In continuing our biographies of 'Bee-keepers at Home,' we have much pleasure in presenting a memoir of the late Hon. Secretary of the British Bee-keepers' Association, the Rev. H. R. Peel, whose labours in that capacity have proved so eminently serviceable in the promotion of bee-keeping in the United Kingdom.

The Rev. H. R. Peel was born on February 8th, 1831, at Canterbury, in the house in the Cathedral Close, now occupied, we believe, by the Bishop Suffragan of Dover. His father, the late Very Rev. John Peel, D.D., afterwards Dean of Worcester, was at that time a Prebendary of Canterbury Cathedral. He was brother to the late Sir Robert Peel, Bart., Prime Minister of England in the year 1834, and from 1841 to 1846. Our Mr. Peel is therefore first-cousin to the present Sir Robert Peel, M.P. for Huntingdon, and to the present Speaker of the House of Commons. At nine years of age the subject of our memoir was placed at a private school at Welford, Northamptonshire, conducted by the Rev. William Waring, subsequently Archdeacon of Hereford, at which we understand that another member of the British Bee-keepers' Association, Sir John Lubbock, Bart., was also educated. From twelve to seventeen years of age Mr. Peel was at Eton College, Dr. Hawtrey being then head master; and, having spent two years at Bremhill, in Wiltshire, as a private pupil of the late Rev. Henry Drury, afterwards Archdeacon of Wilts, and Chaplain of the House of Commons, proceeded to Christ Church College, Oxford, where he remained until he had taken his degrees as Bachelor and Master of Arts.

Both at Eton and Oxford Mr. Peel took honours as a classical scholar, gaining a Fellowship at Christ Church of the value of 40*l.* per annum, and being presented with an honorary class on taking his B.A. degree. He was also well known at Oxford as a cricketer, playing in the Oxford Eleven against Cambridge in the years 1851-1852, as well as for the County of Kent, by virtue of his birthplace. We find from Lillywhite's collection of scores that Mr. Peel did good service for the Gentlemen of Kent against the Gentlemen of England by making 49 and 85 in the two innings played by the Kentish Gentlemen. Mr. Peel was also fond of hunting, rowing, and all athletic sports and exercises. Mr. Peel was instrumental in making the first cricket-ground which Christ Church ever possessed. He was President of the Christ Church Cricket Club, Captain of its Eleven, and the Secretary of the Bullingdon Club.

After his marriage in September, 1853, and his subsequent Ordination in 1854, we find no mention of Mr. Peel in cricket of a public character, with the exception of a match played in 1858 at Leamington (18 Gentlemen of Warwickshire *v.* the Eleven of All England), in which Mr. Peel made upwards of 50 runs. From 1854 to 1855 Mr. Peel held the Curacy of Hallow, in Worcestershire, under the late Venerable Archdeacon Sandford. In 1855 he removed to the Curacy of Charleotte, in Warwickshire, the seat of the Lucy family, where he remained five years, the Rev. John Lucy being then Rector of Hampton Lucy and Charleotte. In 1860 Mr. Peel undertook the more arduous duties of the parish of Handsworth, a suburb of Birmingham, containing at that time about 16,000 inhabitants, where he remained as Rector for twelve years, fully employed by the duties of his office, and having no leisure to devote to those minor occupations and recreations for which country clergymen can often find time. The result of Mr. Peel's work at Handsworth during those twelve years was that the parish

—of a very extensive area—was subdivided into five ecclesiastical districts, each provided with churches, schools, and clergymen of its own. Mr. Peel always carried on his work in the greatest harmony with all the different religious bodies which he found in his parish. We have this expression of his policy from his own lips: 'As long as any work concerned the Church of England alone, I applied for assistance to Churchmen alone; but when any work of general interest was concerned, I appealed to Churchmen and Nonconformists alike, and I never found the appeal unresponded to. I can safely say that no clergyman had a better set of parishioners, Churchmen and Dissenters included, and no parishioners that gave a clergyman more thorough and consistent support.' In confirmation of this we have seen two addresses, presented to Mr. Peel, one on his return to his parish after recovering from one of his attacks of illness in 1869, the other on his resignation of the Rectory of Handsworth in 1873, signed by the leading Churchmen and Nonconformists of his parish.

Mr. Peel was well known in Birmingham and its neighbourhood, as a promoter and supporter of Workingmen's Clubs. He was one of the original committee who, under the leadership of Dr. Miller, then Rector of St. Martin's, Birmingham, set on foot the Hospital Sunday Movement, which has since been adopted in London, and in the principal towns of England. Mr. Peel was for several years Rural Dean of the Deanery of Handsworth, and was well known in 'the Black Country' as an active and zealous clergyman, always ready to contribute towards objects which had the good of his fellow-creatures in view.

Having suffered from three severe attacks of rheumatic fever, from the last of which he recovered contrary to general expectation, Mr. Peel resigned the Rectory of Handsworth in the year 1873, and spent the two following years upon the Mediterranean Sea and its coasts, visiting Venice, Corfu, Athens, Constantinople, Alexandria, Cairo, and other Eastern towns in the course of his voyages.

On the death of his father in 1875, Mr. Peel left Worcestershire, which he had always regarded as his home county, from his father's residence having been fixed in it, and entered upon a seven years' tenancy of Abbot's Hill, the seat of John Dickinson, Esq., near Hemel Hempstead, in Hertfordshire. It was here that Mr. Peel first became connected with the British Bee-keepers' Association. Having been accustomed to see bee-hives in almost every cottager's garden in Worcestershire, and having always regarded them as a possible source of income to cottagers, Mr. Peel thought that it would be beneficial to the labourers employed upon his farm at Abbot's Hill if some instruction were given to them as to the habits of bees, and the profit which might be derived from the intelligent management of them. Mr. Peel, therefore, called on Mr. Alfred Neighbour in Regent Street, and asked him if he could obtain for him the services of some master of the art of bee-keeping who would deliver an address on the subject to his labourers and their families assembled at a harvest home. Mr. Neighbour suggested the name of Mr. Hunter, the then hon. secretary of the British Bee-keepers' Association, who came down to Abbot's Hill and gave an open-air lecture in the garden, surrounded by clergymen, labourers, and others, in which he showed (to most for the first time) how easily bees might be handled, and how profitable they might be made. Great satisfaction having been expressed at Mr. Hunter's address, by those who heard it, Mr. Peel, at Mr. Hunter's request, became a member of the British Bee-keepers' Association. This harvest home took place in the autumn of 1876. In the following year Mr. Peel took some of his labourers and their wives to see the exhibition held at the Crystal Palace.

At the close of the war between Russia and Turkey in

1878, Mr. Peel was again in Constantinople, and upon his return thence to England, the first letter which he opened from a large pile which was awaiting him was a circular asking for the opinions of the members of the British Bee-keepers' Association as to whether the Association should be broken up or not. Mr. Peel, thinking it a great pity that an Association, capable of so much usefulness, should be so summarily brought to a termination, attended the meeting, and, upon Mr. Hunter announcing his intention of abdicating the hon. secretaryship, volunteered to undertake that post on the understanding that the Association would consent to his going on a mission of peace to Mr. Abbott, and endeavouring to effect a reconciliation between him and the Association. The position of the affairs at that juncture was most critical. The original founders of the Association had come to a rupture with Mr. Abbott, the then proprietor of the *Bee Journal*. An attempt had been made, on the one hand, to start a rival journal in opposition to Mr. Abbott; and, on the other hand, a plan had been formed to develop the Lincolnshire Association, then recently established, into a Midland Counties Association, as a rival to the British Bee-keepers' Association. Happily, for the future of the British Bee-keepers' Association, Mr. Peel succeeded in arresting both these projects, and in bringing Mr. Abbott and the Association once more together. Having done this, his first step was to secure the services of Mr. J. Huckle, a resident at King's Langley, near Abbot's Hill, as his assistant-secretary; his next, to obtain the consent of the Baroness Burdett-Coutts, who had been acquainted with his father and with his uncle, to be the President of the Association. The next work was the remodelling of the constitution of the Association. To Mr. Peel the Association owes the idea of the Committee being elected by voting papers, and the system of a vote being allowed for each five shillings subscribed, combined with a limitation that no member shall have more than four votes, which, Mr. Peel informs us, was suggested to his mind by the debaters upon the Reform Bill of 1831. It has certainly worked admirably in the case of the Bee-keepers' Association, and we hope will never be disturbed. As a sequel to this idea came the election of the Chairman of the Committee, and the precedence of its members in the absence of the Chairman, according to the votes received by each at the election. To this system also is due the facility with which six new members were added to the Committee by priority of votes at the last election at the commencement of this year. Many unpleasant wranglings and dissensions as to the election of chairman at the different meetings of the Committee have been avoided by this system; and since its adoption the meetings have always been conducted harmoniously and in an orderly manner.

Mr. Peel took an active part in the revision of the Rules of the Association, and in causing the financial year to date from January 1st instead of May 1st, thus enabling the Association to wind up its accounts at the close of the year, and produce its balance-sheet at the General Meeting in January. When we remember that each of the County Associations now follows suit, and sends up its balance-sheet to be bound up in the volume of collected Reports, which is so useful and of such importance to County Secretaries, the benefit of this policy will become apparent. The usefulness of this volume depends upon its being issued to County Secretaries at the commencement of the year. They can then profit by the experience which they gain from the reports of their neighbours in making their arrangements for the coming season. If the volume does not appear until August or September, it is practically useless until the March or April following. We wish that it were possible to bring this most interesting volume within the reach of every bee-keeper, and the importance of its early issue would then be more generally recognised.

(To be continued.)

#### DEATH OF MR. ALEXANDER PETTIGREW.

It is with much regret that we have to announce the death of Mr. Pettigrew, which occurred on March the 10th. Mr. Pettigrew having for many years occupied a foremost place amongst apiculturists both as a practical bee-keeper, and as a contributor to the apian columns of the *Journal of Horticulture* and as the author of the *Handy Book on Bees*, it had been our intention, at an early date, to have included him amongst the biographies of 'Bee-keepers at Home,' but it has become our melancholy duty to change it into an obituary notice.

In the year 1815 Mr. Pettigrew was born at Carluke, Lanarkshire. His father from the age of twenty to thirty was a common labourer, and during that time he was one of the most advanced and successful of bee-keepers. As the results of bee-keeping his father saved upwards of 300*l.*, which enabled him to buy the 'Black Bull' Inn. The surroundings of Mr. Pettigrew's early life were, therefore, the reverse of advantageous. His father, however, continued to keep bees, and his success encouraged many of his neighbours to do the same. To the present day the bee-keepers in Carluke are numerous and successful, and the annual yield of honey is satisfactory. Mr. Pettigrew imbibed his father's love of bee-keeping, and eventually the management of the hives devolved on him.

At the age of eighteen he went to Carstairs House to learn gardening, and here he spent three years. In 1839 he came to London, and was sent by Mr. Hugh Low, of Clapton, to Lord Mansfield's garden, at Hampstead. Before this time his education had been much neglected, but, having gained possession of Cobbett's *Advice to Young Men* and his *English Grammar*, he sedulously resolved to gain a mastery of the art of speaking and writing his mother tongue. This Mr. Pettigrew considered to be the turning-point of his life. His evenings were now spent in acquiring knowledge and in reading scientific books on gardening and farming. In Scotland he had a knowledge of Mr. William Thomson, who afterwards took charge of a large establishment at Barnet, and Mr. Pettigrew, having spent two years at Hampstead, left it to serve under Mr. Thomson in Wrotham Park, and there he spent four happy years as his foreman.

In 1844 Mr. Pettigrew commenced writing for the press, and began to think he was qualified to take charge of a gentleman's garden. Mr. Thomson commended him to Dr. Lindley, who sent him to serve a gentleman in Yorkshire. After having been there but a short time he returned to London, whence he was sent to Manchester to take charge of the garden of Edward Loyd, Esq., banker, of Cheetham Hill. This situation was a comfortable one, and his employers were exceedingly kind. Here it was that he married, and his family were born. Circumstances having obliged him to leave, we next find him in a situation in Middlesex, where, however, he did not long remain. He was then sent by Mr. James Veitch, of Chelsea, to a gentleman in County Down, in the joint capacity of land steward and gardener, but the engagement was not of long duration. He returned to England, and his next engagement was in the service of a nobleman in Oxfordshire. This situation he entered upon with a determination to make it his last. But fever entered his house and cut down his eldest boy. This frightened the lady of the house so much that she speedily sent him and his family away from the place. He then resolved to take no other situation as gardener, but to commence business as a nurseryman. After two months' search he found a field at Rusholme, near Manchester; here he built a dwelling-house and greenhouse, and for thirteen years he worked hard, and did very well. The place at Rusholme having been sold for building purposes, he went to Sale, in Cheshire; and here, too, he built a dwelling-house, and three large vineries, and grew grapes for eight years. In 1881 he sold the



place to Messrs. Stanfield, and retired to Bowdon, where his purpose was to keep bees, and to sell honey, and to enjoy life much as he could by helping others.

Mr. Pettigrew, while an apprentice at Carstairs, and a journeyman at Wrotham, kept bees in the woods and plantations, and when he became head gardener he managed the bees of his employers, and wrote papers and treatises on the subject of bee-keeping. For upwards of fifty years he had the management of bees.

We have gleaned the above facts in the life of Mr. Pettigrew from an autobiographical sketch in the *Journal of Horticulture* for September 8, 1881; and in announcing his decease it speaks thus feelingly of its former correspondent:—"As a gardener he was able, as an apianian successful, as a member of the community one of the most worthy. He was from youth to old age an earnest seeker after knowledge, and what he acquired he took great delight in imparting to others. He commenced writing for the press forty years ago, and continued without intermission until within two years of his death. His communications to our columns were voluminous and appreciated, and his popular *Handy Book on Bees* has passed through several editions. He clung with characteristic tenacity to the value of large straw skeps for bees, simply because he found they gave him the greatest bulk of honey in return for the least outlay in labour, and also because he could always find a market for his goods; but latterly especially he admitted the great value of the bar-frame hive and the sectional system of management. Perhaps no one has done more to advance bee-keeping than Mr. Pettigrew has during the period indicated. He was a perceiving teacher long before the art became fashionable, and numbers of persons in this and other countries have benefited by his experience, which he so readily communicated through the press. He was a forcible and occasionally a pungent writer, and if he ever found that he had unwittingly given even the slightest pain to a controversialist his letters always showed that he inflicted even greater pain on himself. Honest and upright in all his dealings, intellectual in character, an agreeable companion, a fast friend, and a model parent and husband, the memory of Mr. Pettigrew will be cherished as of one who endeavoured to do his duty and to leave a good name behind him. He leaves a widow, with whom we sympathise in the great loss she has been called to endure."

#### AMONGST THE SWISS BEE-KEEPERS.

No. X.

There is very little evidence that bee-keeping was much taken up in Switzerland from the time of Virgil to the middle of last century. But about 1746 Jacques de Gélien, father of Jonas de Gélien, wrote a treatise of two volumes on bee-keeping. These, however, were not published, but in them he describes wooden box hives with supers, at a later period alluded to and recommended by M. Reaumur. Very little was known of Jacques de Gélien except that he was a bee-keeper with advanced notions. A portion of this treatise was published by M. Pingeon in 1781 in his work entitled *Traité complet, Théorique et Pratique, de l'Éducation des Abeilles*, &c. Of his son, Jonas de Gélien, we know more; and as a writer he makes his appearance first in 1770, and in the *Mémoires de la Société Économique de Vevey* gives an extract from his father's work, which he entitles *Instructions pour les habitants de la Campagne*, &c. Later he published a description of a method of making artificial swarms as adopted by the Bee Society of Luncey. He is, however, better known to us as the author of *Le Conservateur des Abeilles*, which, in 1829, was translated into English under the name of *The Bee Preserver*. Being a scientific man as well as a practical bee-keeper,

his little treatise is full of good advice, and even at that date he pointed out that wooden hives could be made to winter bees equally as well as straw ones.

At about the same time lived Duchet, who in 1761 published his first treatise, entitled *Culture des Abeilles*. He was Chaplain of Remaufens Castle in the Canton Fribourg, and was well up in the bee literature of the period in other countries, for we find him experimenting with pollen to refute Reaumur's statement as to its being one of the constituents of wax. These experiments he describes in his second edition, which he published in 1771 in Vevey. He also invented his supering hives, which were separate boxes with thin boards at the top, in which were holes so as to allow the bees to pass from the stock-hive into the supers with as little trouble as possible. A great number of these hives are still in use all over Switzerland. It is, however, of Huber that the Swiss may well be proud, as it was he who was the first to invent the moveable frame-hive, which has since been so much improved by various bee-keepers as to render bee-keeping, as now practised, no longer a matter of chance, but as certain as any other rural occupation. Being a naturalist, and a scientific man, and having studied all the works on bees he took an interest in, and was led to make a study of them, and in 1792 wrote his *Nouvelles Observations sur les Abeilles*, which he addressed to M. Ch. Bonnet. This book passed through several editions, and was translated into English, German, and other languages, and will ever be looked upon as a standard work upon bees. Although blind he was assisted by his faithful servant Burnens, who was an ardent lover of bees, and who for a number of years was indefatigable in carrying out experiments, and describing the results to his beloved master, which enabled Huber to settle a great many undecided points, which have since been so remarkably corroborated by later observers. For the purpose of making observations, and watching the queen performing her function, he constructed a hive in which the frames were moveable and covered with glass on both sides, and by putting these together formed what is known as the Huber Leaf Hive. It is impossible to enumerate all he did, and the patience and perseverance he brought to bear upon this subject are marvellous. After Huber we find several Swiss authors, namely, J. Boudet, who treats on straw-hives; E. Canev, on stonying hives; H. Berner, on straw-hives; H. C. Hermann, on the Italian Bee, which has been translated into English; A. Mona, also on the Italian bee; and, lastly, *Rational Bee-keeping*, by C. de Ribemont, which has also appeared in English, translated by Mr. A. L. Vesey Gower. In this the author describes a hive with bars only, but it was not until the formation of Bee-keepers' Associations that bee-keeping made any great progress; and as with us so also in Switzerland by holding meetings and publishing journals a great amount of information has been spread, and amongst the progressive bee-keepers the moveable comb hive has been generally adopted. There is still much ignorance and prejudice existing with regard to bees, but this is gradually disappearing; and there is no other country that can produce better honey than Switzerland. One of the first societies formed was the Verein Schweizer Bienerfreunde, in 1861, and had its origin at Olten in the Canton Solothure at a meeting of sixty-three bee-keepers (of whom five are still alive), who were invited by Dr. Christen, of Olten, and M. Schilt, curé of Oberglötschen. The entrance-fee is one franc, and the annual subscription five francs, which entitles every member to a copy of the *Schweizerische Biener Zeitung*. This journal is now published by the Society, but was for some time published by, and at the entire cost of, Peter Jacob, who was president of the society for some years. His name is well known as being one of the first to perfect the invention of M. Mehring, of Frankenthal, for making comb foundation. M. Jeker is the present president, and

M. Kramer is the secretary, and the society now numbers 420 members.

The Société Romande d'Apiculture was established in 1876 to represent the bee-keepers of the French-speaking cantons. M. de Ribeaucourt, who was afterwards elected its first president, got a meeting together by inviting, through the journals, all bee-keepers to meet on a certain day and at a certain hour in Nyon. Fifteen bee-keepers made their appearance, and the Society was formed, with M. Bertrand as secretary. When this gentleman started the *Bulletin d'Apiculture de la Suisse Romande* the number of members rapidly increased from 84 in 1878 to 150, and since then the numbers have been gradually augmenting, so that now there are 273 members. Since the annual meeting in 1883 M. Bertrand has been the elected president. This Society has no journal of its own, but an arrangement is made by which each member receives as it is published the *Bulletin d'Apiculture de la Suisse Romande*. The entrance-fee is 2 francs, and the annual subscription  $\frac{3}{2}$  francs, and M. J. Descouillayes is the secretary. Both these Societies, which have the same status here as our British Beekeepers' Association has in England, hold periodical meetings, and have exhibitions of bees and hives. At the meetings after the ordinary business is gone through, a certain number of questions are put down, and anyone who has anything to say on the subject can do so, and in this way frequently very animated and instructive discussions ensue.

I was invited and attended one of the meetings of the Société Romande d'Apiculture at Lausanne, and here I was honoured by being unanimously elected an honorary member of the Society, and had the opportunity of making a few remarks on some points connected with bee-keeping as practised with us. Besides these meetings, the Swiss Society has, since 1878, every year sent Mr. Jeler to different towns to give a course of lectures. The course lasts a week, and has numbered from twenty to thirty-five students. During 1883 two such courses were held, one at Lucerne, and the other at Rosenberg, near Zug. Mr. Jeler not only gives the lectures, but also performs and describes the practical manipulations. The course generally commences by an address, welcoming those who are to take part, and giving a programme of the work to be done during the six days. On the Monday work commences precisely at six o'clock in the morning, the natural history of the bee being taken first, and the diagrams published by the British Beekeepers' Association are used for illustrating the anatomy of the honey-bee. With a short interval for breakfast, the work is continued until dimer at midday, after which practical manipulations with bees take place. The evenings after supper are devoted to conversation. A similar programme is carried out every day, and at the end an examination takes place. These lectures are attended by persons of all ages and both sexes, and are much appreciated.

In my next article I will describe how the Government assists and encourages bee-keeping, and will also give statistics of bee-keeping in the different cantons.—THOS. WM. COWAN.

#### DEPARTURE FOR NEW ZEALAND OF A NOTED SCOTTISH BEE-KEEPER.

Mr. John Wilkie, of Gonrock, left the Clyde for Auckland, New Zealand, on 14th March, 1884. He was well known in the West of Scotland as a most successful bee-keeper. He took a lively interest in the formation of the Caledonian Apian Society, and has ever since lent his aid in promoting its welfare. As an expert he was cool and collected, and seemed to do nothing in a hurry, and yet as a rule at the various shows was generally a prize-winner. At the Kibble Palace Show in 1876 he transferred a straw-slop to a bar-frame hive in such a

business-like manner, and such a short space of time, that he astonished even Mr. Abbott, who was his unsuccessful opponent. He has since then gained several prizes at the various shows, and notably he was the first winner of the Highland and Agricultural Society's silver medal, offered for the driving competition at the Perth Show in 1879.

It is Mr. Wilkie's intention, when once settled at Auckland, to take up his favourite hobby on a more extensive scale than he has ever done in Scotland, in fact almost bee-farming, so that we may look for a full report from that land said to be flowing with milk and honey; and as he is a concise and ready writer, as we have seen by his articles in the early volumes of the *B. B. Journal*, we hope he will not neglect to let us have at least quarterly reports.

He was one of the first men to take up the notion of bee-guilds, which have been of so much use to England in concentrating bee-keepers and giving vent to their views, so that all benefit thereby, and further the interests of bee-keeping as a science throughout the country.

We wish him God speed on his voyage, and an early settlement in the land of his adoption, and soon hope to learn of him having a successful bee-farm.—R. J. BENNETT, Hon. Sec. Caledonian Apian Society.

## ASSOCIATIONS.

### BRITISH BEE-KEEPERS' ASSOCIATION.

The Committee Meeting was held at 105 Jermyn Street on Wednesday, March 19th. Present, the Rev. H. R. Peel (in the chair), the Rev. E. Bartrum, the Hon. and Rev. H. Bligh, Capt. Bush, H. Jonas, J. M. Hooker, Rev. F. G. Jenyns, Mr. Walter Martin, Rev. G. Raynor, Rev. F. S. Schärer, Dr. Stewart, W. O'B. Glennie (treasurer), and the secretary. The minutes of the last meeting were read, confirmed, and signed. Mr. Stewart reported that the executive of the International Health Exhibition had allotted a limited amount of space to the Association for an exhibition of honey and appliances as illustrative of the bee-keeping industry throughout the United Kingdom. The question of the arrangements of this Exhibition was discussed at considerable length. Ultimately it was resolved, 'That the space offered be accepted, and that a guarantee fund of 100*l.* be raised to insure against loss, on the understanding that this Exhibition be held in lieu of the Annual Metropolitan Show, and that no call be made upon the guarantors unless any loss that might be incurred should be greater than the funds of the Association were enabled to meet.' The Exhibition Sub-committee were instructed to make the necessary arrangements for this Exhibition.

The Rev. E. Bartrum and the Rev. F. G. Jenyns submitted proposals for the arrangement of local examinations of experts. Resolved, 'That the same be considered by the sub-committee; their proposals to be submitted at the next quarterly meeting.' The secretary reported that the Northamptonshire Association were in arrears with their payments due for the attendance of experts at local shows in 1883. The secretary was requested to write to one of the late hon. secretaries previous to taking any action for the recovery of the amount.

Resolved, 'That arrangements be made for the second Bligh Competition, and that the sub-committee do make the necessary arrangements on as early a date as possible.'

The Hon. and Rev. H. Bligh, the Rev. F. T. Scott, and Mr. J. M. Hooker, were appointed as judges at the Maidstone Show.

The next quarterly meeting of county representatives will take place on Wednesday, April 16, at 105 Jermyn Street, London, S.W., commencing at 4.30. Subjects for discussion—(1) The arrangements for the collection and disposal of the Peel Testimonial Fund. (2) The mode of electing representatives of County Associations to attend the quarterly meetings of the British Bee-keepers' Association. (3) Local examinations of experts.

The usual Conversation will be held at 6 p.m., when a paper will be read by Mr. Frank R. Ches-hire, subject, 'Honey as Food.'

#### HANTS AND ISLE OF WIGHT BEE-KEEPERS' ASSOCIATION.

The Annual General Meeting of this Association was held on Thursday, March 15th, at the rooms of the S. P. C. K., No. 6 Portland Street, Southampton. There were present, Col. Farquhar, Captain and Mrs. Suckling, Miss Palmer, Rev. P. P. Izard, Rev. W. E. Medlicott, Wm. Wynyard, Esq., S. H. Gould Adams, Esq., Henry Daniell, Esq. (Hon. Treasurer), the Hon. Secretary and Mrs. Bellairs, and others. The Rev. W. E. Medlicott was voted to the chair, and in alluding to the report said he could heartily congratulate the members upon the satisfactory condition and prospects of the Association. Although the Society was little older than one year 116 members had been enrolled, and the state of the finances was eminently satisfactory. The bee tent had been sent to many of the chief towns during last summer, and although this had involved a large expenditure the Society had met it and come through the winter with 5*l.* 17*s.* 5*d.* cash in hand. The total expenditure of the Association had amounted to 129*l.* 8*s.* 11*d.*, the whole of which had been spent in furthering the cause of the Society, viz., the advancement of bee-keeping as a means of enriching the poor. In alluding to the statement of accounts he thought the Hon. Secretary was to be congratulated upon his great exactness and conscientiousness in keeping them. The figures were an exact transcript of the books of the Association, and he had only to point out that the *totals* on either side did not *yet* represent the income of the Association as the account in full with the Hon. Treasurer was included, and not the mere balance. He begged to move the adoption of the report, together with the statement of accounts, as printed.

The Hon. Secretary, after remarking upon the various items and the liberal way the Association had been supported by several kindred Societies, and especially the Royal Southampton Horticultural Society, said that he had, in drawing up the accounts, given a preference to the system, more common in Scotland than in England, of giving in full the actual cash transactions with the Hon. Treasurer, so that members could see for themselves the actual sums paid into the bank and those drawn out. For many reasons this method appeared superior to a mere statement of 'Balance,' which conveyed no very distinct information. The vote of the Chairman was seconded by F. J. B. Beckford, Esq., and carried unanimously, together with a vote of thanks to the Christchurch manager of the Wilts and Dorset Bank for acting as auditor. Votes of thanks were also passed for the Royal Southampton Horticultural Society in recognition of the great aid they accorded the Association last summer; and for the President, Officers, and Committee for last year. The following gentlemen were elected to serve for this year, viz., Lieut.-Col. Farquhar, Rev. W. E. Medlicott, Rev. J. Pemberton Bartlett, Dr. S. Andrews, S. H. Gould Adams, Esq., Rev. Arthur B. Cotton, F. J. B. Beckford, Esq., Dr. T. W. Blake, Dr. Tie-hurst, Rev. H. W. Bull, Captain Suckling, and Mr. Baigent.

A special grant of five pounds was unanimously ordered to be paid the British Bee-keepers' Association

in addition to the usual affiliation of one guinea, 'in recognition of the many and great services rendered the bee-keeping fraternity by that Association.'

The meeting discussed at some length various projects brought forward by different members for the further encouragement of bee-keeping amongst the poor of the county, the evident opinion being that a hasty condemnation of the straw skep for cottagers was to be avoided. The subject of a Honey Depot for the sale of members' honey was also fully gone into, the Hon. Secretary stating it as his opinion that it would *pay* the Hants Association to subscribe 10*l.* annually to the Parent Association if the latter would organize a Central Depot in London where a ready sale could be assured. With regard to the best way to instruct cottagers in the art of bee-keeping he thought the suggestion thrown out by the Chairman (Mr. Medlicott) of extreme value; and as he did not remember to have heard of it before he would urge it upon all those who had the object at heart; it was to the effect that cottagers should be supplied with a good frame-hive by way of a *loan* from their wealthy neighbours, to be repaid out of the profits arising from the sale of honey, &c. After some remarks from Mr. Giles, a 'boni fide' cottager, as to how he came to be an advanced and successful bee-keeper from having originally kept a few skeps only, the meeting terminated with a vote of thanks to the Chairman for presiding.

#### SUSSEX BEE-KEEPERS' ASSOCIATION.

The Third Annual General Meeting of the Association was held on Wednesday, Feb. 20th, at the Town Hall, Brighton. In the unavoidable absence of the President, the Earl of Chichester, the chair was taken by W. Woodward, Esq., of Henfield.

The Chairman, in moving the adoption of the Report, congratulated the members on the flourishing condition of the Association, both in point of numbers, in which it stood head of the County Associations of England, and also financially, the deficit of last year amounting to nearly 10*l.* having given place to a balance in hand of 3*l.*

On the motion of Mr. Jackson, the officers of the past year were re-elected, with the addition among the Vice-presidents of the Duke of Norfolk, the Duke of Richmond and Gordon, and Sir T. Brassey, K.C.B.

It was resolved that it would be desirable to purchase a second bee-tent, the Secretary having had during the past year to refuse many applications from local flower-shows for the one tent now in use.

It was also decided that in the event of cottagers requiring a second visit in the year from the expert, they should send a donation of 1*s.* 6*d.* to the Secretary in addition to the 1*s.* already subscribed.

Four prize hives were then drawn for, two for members and two for cottagers. The winners were R. Loder, Esq., M.P., and T. Dimmer, Esq., of Jovington Polegate. Cottage members—W. Cook of Warnham and H. Rapley of Balcombe Tunnel Crawley.

A vote of thanks to the Mayor and Corporation of Brighton for the use of the room, and to the Chairman for the able way in which he had presided at the meeting, brought the proceedings to a conclusion.

#### HUNTS BEE-KEEPERS' ASSOCIATION.

The first committee meeting of the newly-elected committee was held at the Fountain Hotel at Huntingdon on Saturday, March 15th. The chair was taken by A. W. Marshall, Esq. Although the meeting was not large a great amount of work was got through. The Committee decided that a bee-tent should be sent to the horticultural shows at St. Ives, St. Neots, and

Ramsey; and that the annual show of bee-products should be held at St. Ives Horticultural Show. It was thought advisable that an exhibition of some kind should be held at Huntingdon, it being the most important town in the county; but as no gathering takes place to which a bee-tent could be sent, the committee decided to have a bee-tent and sale of honey during the first week in July, in some suitable grounds for which arrangements will be made. Should the undertaking not be a financial success, the Chairman kindly promised to pay the loss. There are many advanced bee-keepers in and around Huntingdon, and it is hoped they will help to their utmost to make the show a success. As the expenses this year will doubtless be greater than last, Mr. Howard of Holme kindly offered to assist the Association by being hon. expert at Ramsey; and suggested that Mr. Eley should be asked to do the same at St. Neots. The Committee accepted Mr. Howard's offer, and directed the hon. sec. to communicate with Mr. Eley on the subject. Mr. Eley has since promised to give his services at the St. Neots Show. The remaining time of the Committee was taken up in arranging the prize list for the annual show.—C. N. WHITE, *Hon. Sec.*

#### CAMBRIDGESHIRE AND ISLE OF ELY BEE-KEEPERS' ASSOCIATION.

A Committee Meeting of the above Association was held at the offices of the Society, Alexandra Street, at 2 o'clock on Monday, the 10th March, 1884, when the accounts for the year 1883 were produced by the Secretary, and duly audited and found correct. The Secretary also produced his Report for 1883 for perusal and confirmation by the Committee.

Subsequently, at 3 o'clock on the same day and at the same place, the Annual General Meeting of the Association was held, when the President, Vice-Presidents, Treasurer, and Secretary, were re-elected. The Assistant Secretary, Rev. O. H. Mosley, was also re-appointed, and in addition Messrs. Matthews and Holding were chosen as Assistant Secretaries for their respective districts. The Committee were all re-elected with the exception of Dr. Conder, who had left the neighbourhood; Mr. Edward Pullen, of Great Shelford, was chosen to fill the vacant place. The Secretary read the Report, which was adopted and ordered to be printed and circulated. The usual vote of thanks was accorded to the Secretary for his services during the past year, and to the chairman for presiding. Some desultory conversation ensued with reference to certain subjects to be discussed at the next Committee Meeting, and it was arranged the Secretary should issue notices for a meeting on an early day.

#### CHESHIRE COUNTY BEE-KEEPERS' ASSOCIATION.

The Second Annual Meeting of the members of the above Association was held at the 'British Workman,' Altrincham, on the 18th Feb., H. Simpson, Esq., M.D., presiding. The Association during the past year has made steady progress, especially in the district represented by it before the adoption of the county title, at the instance of the Secretary of the British Bee-keepers' Association. The Annual Show was held in September, in connexion with the Altrincham Agricultural Society's Show, and proved a great success, many more paying for admission than last year. The Judges were, Mr. Carr, of Newton Heath, and Mr. Bream, of Manchester, both experienced experts, whose awards gave entire satisfaction. The exhibits occupied a large tent, beside which was a manipulating-tent from the British Bee-keepers' Association, in which the driving contests excited great interest and proved a great attraction. The Association

has also been represented at Over and at Lydm during the past season in connexion with the local flower shows, medals and certificates being awarded for the best exhibits. The balance-sheet shows the receipts to have been 99*l.* 10*s.* 2*d.*, and the expenditure 65*l.* 14*s.* 9*d.*, leaving a cash balance of 33*l.* 15*s.* 5*d.*, and with other assets a gross total of 41*l.* 7*s.* 11*d.* The number of members has increased during the year from 141 to 174, an increase of 33. After a few necessary alterations in the rules, a cordial vote of thanks to Mr. Johnson, the retiring hon. sec., for his services in the past year, was unanimously given, and acknowledged. The election of officers was then proceeded with, the Association being most fortunate in securing an able successor to Mr. Johnson as hon. secretary in Mr. Cotterill, a well-known apiarist, and one of the founders of the Association, who was along with Mr. Bush, the hon. treasurer, elected as representative to the meetings of the British Bee-keepers' Association.

#### BEDFORDSHIRE BEE-KEEPERS' ASSOCIATION.

The Beds Bee-keepers' Association held its Annual General Meeting at Bedford on the 15th of March, A. Pym, Esq., in the chair. The secretary read the report of the expert's visits in the county in the spring of 1883, which showed rather a low standard of excellence. The treasurer gave a statement of accounts, which gave a small balance in hand. Officers for the year were then elected. The meeting decided to accept the kind offers of certain gentlemen in the county, who are experienced bee-keepers, to visit the apiaries of members in their several districts, and to give advice on bee-management. The meeting also resolved to offer prizes for honey and bee-appliances at the flower show to be held in Bedford in July. A bar-frame hive was then drawn for among the members, which was won by Mr. Phillips. The books show a slight increase of members during the past year.

#### GLOUCESTERSHIRE BEE-KEEPERS' ASSOCIATION.

I have pleasure in informing you that the Gloucestershire Bee Association is now started. We had a meeting at Cheltenham on the 20th ult., to which those in the county most interested in bee-keeping were invited. An influential Committee was formed, and other preliminary business transacted. Messrs. E. J. Burt and E. A. Brown have kindly undertaken to act as local secretaries for the Gloucester district; Mr. C. Marshall, jun., will do the same for Cheltenham; and Mr. Cook for Fairford; and we shall be pleased to hear of others willing to help in the various other centres. A circular will be shortly issued and distributed, giving all information; but in the meantime I shall be pleased to give further details to any one wishing to join. The Central Association, with their usual liberality, have offered to help; and, judging by the number who have already joined us, we believe that our efforts will be successful.—WM. ZACHARY, *Cirencester, Hon. Sec.*

#### IRISH BEE-KEEPERS' ASSOCIATION.

The Annual Report of the Irish Bee-keepers' Association states that it is in a good financial condition, and is also prepared to do good and useful work during the present season. The first bee show of the past year was held, by the kind permission of Royal Horticultural Society and Mr. E. C. Guinness, at the spring flower-show, which took place in Mr. Guinness's grounds off Harcourt Street. The Rev. H. J. Silthorp was kind enough to lecture and manipulate the bees, and worked hard to make the Show a success. The tent was also

erected at the agricultural show at Limerick, by the kind permission of the local Committee, who contributed handsomely towards the expenses. Mr. Thomas B. Blow, of Welwyn, Herts, expert of the British Bee-keepers' Association, was engaged to lecture and act as expert in the tent, which was under the management of Mr. J. Edmondson, who was assisted by Mr. A. Davis. The Rev. George Proctor and Brother Joseph were also kind enough to assist in the manipulation of the bees, and showed their well-known skill in doing so. This Show was well attended, and it is hoped may serve to create an interest in the profitable and humane management of bees. A show of hives and honey was held at the Dairy Show at Balls Bridge on October 24th, in connexion with the Royal Dublin Society, but the Committee thought the season too far advanced for manipulations with bees in the tent. The show of hives and appliances was large and creditable, and the Judges were of opinion that there was a decided improvement on former shows in the number and quality of the exhibits. The quantity of honey shown was small, owing to the extremely unfavourable season. Nevertheless, some fine sections were exhibited by Rev. J. M. Aldridge and Captain W. Riall, and good prices were obtained for any that was fairly good in quality. It has been decided that sections, to be recognised as one-pound sections at the honey shows held by Association, must in future measure either 4½ ins. by 4½ ins. or 4½ ins. by 4 ins. Those of other measurements will not be eligible for competition as one-pound sections.

The Association propose to hold a show of bees, hives, and bee-furniture at the Royal Dublin Society's Spring Show at Balls Bridge, on Tuesday, 15th April, and three following days.

## Correspondence.

\*. \* All Correspondents forwarding Letters for insertion in the Journal, Reports of Associations, Shows, Meetings, Echoes from the Hives, Queries, &c., are requested to direct their communications to 'The Editor of the "British Bee Journal," c/o Messrs. Strangeways & Sons, Tower Street, Upper St. Martin's Lane, W.C.'

### OUR HONEY IMPORTS.

The value of honey imported into the United Kingdom during the month of February, 1884, amounted to 22344. [From a private return sent by the Principal of the Statistical Office, H.M. Customs, to E. H. Bellairs, Wingfield, Christchurch.]

### PEEL TESTIMONIAL FUND.

The suggestions of your correspondent, 'British Bee,' are worthy of the best consideration of the Committee of the B.B.K.A.; such an arrangement would tend to stimulate the existing County Associations, and would further assist the formation of new Associations. The Irish and Scotch Associations might then think it beneficial to their interests to throw in their lot with the British, and thus form one united body for the furtherance of this good work. The question of the disposal of the amount allotted to each Association should, I think, be left to the County Association itself, subject to the approval of the central body. One county might be benefited most by offering prizes for the best-managed cottage apiaries; another by the distribution of flat-topped skeps at a cheap rate, &c. If the County Associations are left to decide this matter themselves, a much larger interest would be taken in such a scheme than if a fixed mode for its disposal was arranged by the meeting to be held on April 16th.—Nemo.

### PEEL TESTIMONIAL FUND.

I quite approve of the suggestion made by 'British Bee' as to the purpose to which the Peel Testimonial Fund should be applied, and think that it would prove a great incentive as well as assistance to County Associations in carrying out their work of educating cottagers and artisans in the art of bee-keeping. In my opinion it will be of great advantage also to the British Bee-keepers' Association, not only in promoting the growth of new County Associations, but in having its rules and regulations in respect of these Associations more strictly carried out, as I presume that no Association which refused a balance-sheet and declined to send a report would be allowed to participate in the ballot. The best-managed Associations will reap the most advantage, and this is what we should all wish to see.—C. M.

### BLIGH COMPETITION.

FROM 'HAMPSHIRE HOG.'

I hope, Mr. Editor, I am not too late to have a word on this point, as I can't let that 'Paddy' have it all his own way without a *grunt* from myself. Why doesn't the Irish Association, of which we hear so much, hold a Bligh Competition of its own? From what I have read in the *Journal* I gather that our Association spent some 50l. in introducing bee-keeping into Ireland, and I don't find that they have done anything for us in return. They will get all they can out of us, never fear; but when it comes to any help or assistance from them, they thank you for it. Let the British Association stick to the County Associations—some of which do come forward and help it in times of need—and make the Bligh Competition one of the privileges attached to affiliation. The County Secretaries will, or ought to, be ready to act as their agents in carrying it out. Have as many different kinds of hives in it as you like, but keep it in the County Associations. It may stir up some of the drone counties to start Associations when they find they can get something by it.

I like that idea of 'British Bee' in your last issue—the Peel Fund for the same reason, and I'm sure it's the best idea out yet. It would do the Associations a deal of good. Wouldn't they be keen over the ballot!—HAMPSHIRE HOG.

### BLIGH COMPETITION.

May I venture to trouble you with a few words in reply to 'Woodleigh's' letter in your last issue? While agreeing with him in considering that the production of honey and wax should be the only legitimate source of profit in the competition, I fail to see that it is desirable to hamper the competitors in any way, whether by prohibiting artificial swarming, or by rules in favour of the bar-frame hive, or by the endeavour to show the 'poor cottager "Hodge"' the superiority of any particular system of bee-keeping, modern or otherwise. Considerable amusement is caused at certain bee lectures by illustrations from the magic lantern representing 'The straw-skipper contemplating his bees-shed after a hard winter.' May I suggest that when endeavouring to find a class in some good show in which to exhibit his hives he becomes still more amusingly ridiculous?—E. K. E.

### BLIGH COMPETITION.

I would strongly urge that the rules for this next competition should be arranged by the Committee so that the following objects may be obtained:—In the first place, surplus honey; not queens and pampered exotic swarms, but real genuine honey; and if possible ensure the quality and density of run honey. In the second place, let the plan be simple: a good substantial hive

worked on one of the many approved simple systems. Here I would impress that a bee-keepers' carpentering skill should be outside the competition, and that the capital for hive should be limited to the hive, and be in that respect liberal; it is not an object to encourage makeshift hives, and here we may vaguely trace the cause of so many failures in last competition. In the third place, let persons compete who are outside a County Association, wherever supervision may be possible, so that in the counties mostly requiring attention competition hives could be started. And lastly, allow 'Hodge's' old system of travelling to the moors. I am willing to subscribe one guinea.—FREDERICK W. SOAMES, *Wreaham, March 18th.*

#### COUNTY EXPERTS.

Allow me to make a few suggestions for the easier examination of 'Plate-layer' and other hard-working men like himself, who love their bees, but have neither time nor money to enable them to go up to London.

1. Let the examination consist of two parts, paper-work and *visu voce*. Let these be held at different times and places, and none be eligible for the latter who have not qualified for the former.

2. Let all candidates send in their names to the secretary of the County Associations, say at Christmas, or other suitable time, and let him forward the names and addresses to the B. B. K. A.

3. Let the B. B. K. A. forward sealed papers to the county secretaries.

4. Let the county secretaries arrange convenient centres for the candidates; a centre, if possible, to be within four miles of every candidate.

5. Let the clergyman of the parish, or other responsible person, be invited to be present at such examination, and so vouch for its being honourably conducted.

6. Let this responsible person open the papers in the presence of the candidates, and seal up and direct their papers, when completed, in their presence.

7. Let the examination extend over more than one evening, if necessary; but let no one paper be longer than one hour and a half. Quite long enough for a man who has been at hard manual labour since six or seven in the morning.

8. Let the examination take place at seven o'clock in the winter evenings, by which labourers would have time to have their teas and get ready.

9. Let all papers be sent direct to the B. B. K. A., and let those who qualify be directed to appear at the County Show, held in the following manner, and be there subjected to a *visu voce* examination.

10. Let no mark be lost by errors in spelling, as long as the meaning is evident.

I venture to offer these suggestions because I consider 'Plate-layer's' letters most valuable. It is a voice from the people, and should be treated with the greatest courtesy. I am sure he is right, that as a rule cottagers would prefer to commit their fellow-cottagers, and such, too, is the opinion of one of 'Plate-layer's' own class, who consults me very freely, I am glad to say.—J. O. COSSMAKER, M.A., *Vicar of Westwood, Cordruy.*

#### DISTRICT ADVISERS AND COTTAGE BEE-KEEPING.

Allow me to supplement the letter of a 'Herts District Adviser' in the last *Bee Journal*, by sending you the rule to which he refers:—The Committee shall endeavour to enlist the services of amateurs of experience in different parts of the county as voluntary helpers to cottagers; and that a list shall be kept of such volunteers and of the districts in which they undertake to assist. So that every cottager, being a member, may know to whom he

may apply at any time for practical assistance in the management of his bees.'

And, further, allow me to say that it is very essential to the working of the system that the experts during their spring visits should leave with every such cottager a printed paper filled in with the name and address of the adviser in whose district the member is situated. And this paper should very clearly state in a few words that, in case of any difficulty whatever with his bees, he need not scruple to make application for assistance, and that it will be willingly given him by a personal visit or otherwise free of all charge. It is not sufficient to tell them that they can apply to such or such a person. They will scruple to do so unless they have it before them in black and white as an invitation.

I am convinced that such a system, if efficiently worked, will do, perhaps, more than anything to extend intelligent bee-keeping amongst the artisan and labourer classes. It is only a quiet work. It can only be a gradual leavening of the mass, but this is what we must look to, and be content with. Much undoubtedly is done by shows, but, I think, our experience is, that however useful shows are in many ways, yet that very few real cottagers do, or can attend them at the cost of a day's work and often a railway fare, and of course extra refreshment; and that they shrink from exhibiting at the shows because of the expense, and risk, and difficulties of the carriage of their honey there and back. I speak more especially of the larger shows, held probably in the county town.

And while speaking of shows, may I make another suggestion in view of the schedule of prizes soon to be arranged? It is this—that, in order to encourage cottage bee-keeping, it would be a great thing if County Associations would give prizes for best cottage apiaries, containing at least one bar-frame hive, the same to be judged, under certain rules, in the cottage gardens as they stand. Those who have had to do with cottage gardening know that the prizes which really do most good are those which are given, not for a few flowers or a few apples or gooseberries brought to a show, but for the best-cultivated gardens, whether great or small, and for the best collections of flowers standing in the cottage windows, judged on the spot. These are great difficulties, I know, but they are not insuperable, if only the area is not too large. And I am sure such a system of prizes might be instituted for cottage bee-keeping with great benefit.—F. G. JENYNS, *Knebworth Rectory.*

#### DISTRICT ADVISERS.

The Herts plan of appointing 'district advisers' is, I am sure, a most useful one, and one which we have in our Association adopted from the first in practice. That is to say, nearly all the various members of our Committee, and all our six District Secretaries, were selected chiefly for this purpose; and I can safely say that at least one third of our members have been gained by their zealous and friendly efforts. I fully endorse Rev. G. Raynor's remarks as to intercourse with the labouring classes. Only be friendly with them, and speak their own English to them, and little reserve or shyness will be met with.—W. E. BURKITT, *Hon. Sec. and Expert of Wilts B. K. A.*

#### MAKING SKEPS.

Permit me to suggest an improvement on your direction for making skeps. I think you will admit that it would be well to avoid the ragged edge caused by cutting the hole larger. I have my skeps worked, not on the old-fashioned wooden peg of an inch and a half diameter, which is commonly left sticking six inches into the hive, but on a wine-bottle. This, in a flat-top gives me all the space I want. For feeding, I peg down a piece of per-

forated zinc with four halves of hairpins shaped like whole ones, or with the heads rather more square; and for supering I fix in the same way a tin slide, of which I send a sketch.

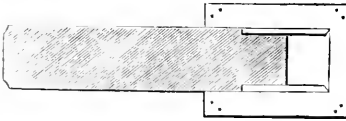

The shaded part shows the slide half drawn.

I will only add that a flower-pot is a good protection to the feeding-bottle under the hackle; other fittings experience and ingenuity will provide.—C. R. S., *South Cornwall*.

#### REGULATING POSITION OF FRAMES.

I send you a sketch of a very simple device I have discovered for regulating the position of the frames in moveable comb-hives, which may perhaps be useful to some of your readers. The device consists in driving wire nails through the top bar and into the side bars at the distance of a quarter of an inch from the latter. This method has, I think, the following points in its favour. It is simplicity itself, is applicable to all frames, and by its adoption the bar is strengthened, and the risk of crushing a bee reduced to a minimum. The frame by its use is practically self-adjusting, and may be dropped into the hive in the dark, and it will find its proper place—though of course no one would be so foolish as to try it with the bees in.—F. BOYES, *Beverly*.

[This device is so simple that there is no necessity for reproducing the sketch forwarded. The same idea is mentioned by Mr. Lyon in his paper on 'Cheap Hives,' Vol. VIII, p. 212; 'Before nailing the pieces together, we must provide for the preservation of the  $\frac{1}{4}$  space. This I do by making a hole with my brad-awl diagonally from the marks through the top bar, and, when nailed together, driving a French nail through the hole into each of the side pieces.'—Ed.]

#### HOW I MAKE MY FRAMES AND DISTANCE-KEEPERS.

This subject has been very quiet lately, except that Mr. Simmins recommends tacks or staples. I could not do with them, they may keep the frames in their proper places, &c., but they do not keep the warm air from escaping; those I make answer for both purposes, and can be removed at any time, even while in the hive if required, or when extracting; and when the quilt is on they retain the heat. If I had no distance-keepers on my frames I could not keep the bees in, to say nothing of the warmth of the interior; the bees would come out and, possibly, not find their way back; no hive can be perfect without them. I am a wood-turner by trade, and find my profession very useful in bee-keeping, hive-building, &c.; I have any size circular saws, water-power, &c. To make the distance-keepers, I take a piece of wood same thickness as top bar, say  $\frac{1}{2}$  of an inch, and turn from four to six at once. I have a cheque, with a square hole in it, in the spindle, and a she centre in the slide; this cannot split them. To get the exact length, I have a cutter. It is about 6 inches in length, with an aft and ground well back, and from the under-side the corners to be very sharp. I simply run the points in to mark the length, and turn the pin with a  $\frac{1}{4}$  inch chisel, the pin is rather over  $\frac{1}{2}$  inch in thickness, and about  $\frac{1}{8}$  in length. I bore a hole in each end of the top bar, on opposite sides, fit the pin rather tight; the holes must be put in so that the distance-keepers are just 15 inches apart, same as my

hives are, from side to side. If they are put on at the right place, there is very little room for propolis, and when in use they look very neat; and I am sure they have every advantage over all others: they are easy to remove, and can be made much cheaper than metal, besides being much warmer, in my opinion. Metal of any kind is better out of the hive than in. For runners, I use thin strips of hard wood, say beech. In making my frames, I turn a pin on each end of the end bars, and bore a hole in each end of the top and bottom bars to fit. I then put them together with a little glue; I don't put a nail in at all. The bottom rail is cut a little longer till the glue sets, then cut off level with the end bar. I have given you the details to the best of my ability. If any of our bee-keepers should succeed in following it out, I am sure they will be well paid for their labour.—ROBT. PHILLIPSON, *Kewick*.

#### MESSRS. HARRISON'S METAL ENDS.

As Dr. Pine's remarks on our metal ends may be the means of injuring us in our business, we should be glad if you will kindly allow us a word in return. If we allow him the honour of the first invention, it is to be regretted that instead of putting such an article before the world he had brought forth a more finished one, and so left less room for the improvements at which he sneers, but which, judging from the sale we have, other people believe in. The increasing demand for them also proves that they are not likely to bring discredit on metal ends generally. His chief objections seem to be to the top-bar and to the acute angle all along the hive-side. The end we now offer, and which you favourably commented on in a late issue of the *Journal*, was made at first with open top, but was soon discarded for one with top-bar, which we make to project one-eighth inch above. This we find convenient rather than otherwise, while it also does away with cutting the frame. We also make our super-plates to fit exactly between these two projections. We never find the quilt glued down to the metal ends. As for the acute angle being filled with propolis, all we can say is, that after long use in our own hives, we have never found it done. Would it not be well to speak more from actual experience than from mere theory?

Were it not for Dr. Pine's intemperate remarks, we may feel grateful for his respect and for his gracious admission that we had not 'servilely followed' him.—HARRISON & Co., *Combs Wood, Halesowen, Worcester-shire*.

#### Echoes from the Hives.

*West Gloucestershire*.—The weather since my last has been very changeable. From 22nd Feb. to 2nd March, dry and cold, with occasional storms; 3rd and 4th, heavy rain; 5th and 6th, nice warm sunshine, bringing the bees out strong; 7th to 11th, dry, cold wind; 12th and 13th, stormy; 14th to 19th, mild and warm—bees busy carrying in pollen; 20th to 27th, very dry, cold east wind, and hardly a bee visible.—R. W. L.

*Huntingdonshire, Somersham*.—Work in the apiary has now begun in earnest. With the exception of the last few days, which have been rather cold, the weather during the month has been remarkably fine. Stocks are increasing in numbers fast. Contrary to my expectations, very few colonies have been lost through starvation. The bees are now carrying in pollen from its natural sources in large quantities. When out beturing in different parts of the county, I have taken the opportunity of visiting the various bee-keepers; and I have found that although most are behind the times, they are generally willing to listen to and promise to profit by the advice I give. I gave an address at Waresley on

Friday, March 14, at the request of Lady Caroline Duncombe. Her ladyship is anxious that the cottagers should be taught how to make bee-keeping more profitable, and how to utilise their bees in the autumn instead of stifling them; and with that object in view her ladyship has engaged me professionally to show the cottagers in May driving and the various operations I explained at the meeting. I make this known in the hope that her ladyship's example will be followed in other parts of the country. Blossom is beginning to meet the eye in this district in all directions.—G. N. WHITE.

*Staffordshire, Stone.*—*Early Swarm.*—A somewhat remarkable incident, brought about through the mild weather that has lately been experienced, occurred near Stone on Sunday. Mr. T. Sharlow, of the 'Three Crowns' Inn, Little Stoke, observed a swarm of bees fly across to a wall at the residence of Mr. J. Sharlow, Stoke Villa, where they settled. Mr. Sharlow immediately procured a hive and safely housed them. It is considered an unusual occurrence for bees to swarm in May, but to do so in March is almost unprecedented.

*Kent, Tonbridge.*—Bees are having a fine time of it in this district; the palm-bloom upon the willows is a picture worth seeing in many places, and bees are taking every advantage of the weather to get as much out of it as they possibly can. From March 14th to 15th, five splendid days, particularly Sunday 16th, bees commenced work about 8 a.m., and continued hard at it until quite dusk in the evening. I have one hive that increased over 20 lbs. in weight in the five days; it is heavier now than when I put it into winter quarters, and it has not been fed or stimulated in any way during the winter until March 6th, I gave it about 2 ozs. of candy under the quilt; and most of my other hives must have done as well, as they are strong in bees and were working quite as hard. 19th to 22nd bees did not fly much, it being too cold for them, wind N.W. Sunday the 23rd, bees are full swing again to-day, large numbers of young bees out to-day, the hives being considerably stronger in bees than they were a week ago. Prospects are very cheering for them at present; blackthorn, plums, and pears are showing well for bloom, and apples in some places. I have not heard of many losses this winter, as most people are beginning to listen to reason and feed their bees in the autumn.—J. FRANCIS.

*Leamington, Weston, March 20th.*—The past fortnight has been grand weather here for bees; and haven't they enjoyed it? They have been busy carrying in pollen, both natural and artificial. There are a few plum-trees that are out in full bloom, which are visited by thousands of bees. Many more will be out in a few days if we get nice weather, but we have had a change to cold and stormy weather to-day. There are also lots of furze and palms in full bloom, while the later sorts will be coming into bloom by-and-by.—JOHN WALTON.

*Yorkshire, Beverley, March 20th.*—I am glad to say my stocks have all wintered safely so far, and they are all busy carrying in large quantities of pollen. I have not disturbed them yet, only one, and found the queen active and looking well, with plenty of sealed brood, &c.; the others I have just turned up the quilt a little, to ascertain if they had plenty of food, which they have. Those fed up with syrup in the autumn seem the most active and the healthiest, and appear to have eaten the least. I fear we shall have a long spell of cold weather to make up for the exceptionally mild winter.—F. B.

*Essex, Springfield, March 22.*—We are now at work examining the apiaries of our members. So far we find colonies unusually strong. Brood, I imagine, has been raised more or less throughout the winter. I have commenced stimulative feeding this week; my hives are well stored with food; I have never known stocks so heavy at this time of the year. The weather has been fine and dry for the past fortnight, the temperature being

very changeable: on Monday, March 17th, the thermometer stood at 65 deg. in a north shade; we are now having frosty mornings, and to-day I found ice. Though we may yet have frost and snow, I think our bees are in a position to withstand any unfavourable changes.—G. H. A.

*North Leicestershire.*—Since my last report on the 9th inst. up to date (24th inst.), the bees have only had two blank days, 20th and 21st. The extraordinary warm weather which prevailed from 14th to 19th gave the bees an opportunity of finishing off with the snowdrops and crocuses, and set them well to work on coltsfoot and willow. Reports of dead stocks, especially in skep-hives, still come in, but it is hoped that all danger of further loss is now past. On Monday 17th the thermometer rose to 64°.—E. B.

*Wilts, Hungerford, March 24th.*—Many losses among cottagers, and still more among those who have *unadvisedly* adopted bar-frame hives, extracted all available honey last season, and then neglected the all-important matter of feeding. I am more than ever convinced of the folly of persuading people to adopt bar-frame hives, who wish their bees to take care of themselves, and repair their own hives, and at the same time make over all their stores to the master. About one-half of stocks lately inspected are in good order. Crocuses just over, opening first on Feb. 14th; but during the five weeks they were out cold and high winds only allowed the bees to visit them on four days. Breeding is consequently late in the colder parts of the county. A slight case of foul brood in my own apiary discovered last August has been completely cured by following Mr. Cowan's advice.—W. E. BURKITT, Hon. Sec. W. B. K. A.

*Suffolk, Houghley, March 28th.*—The mildness of the weather day by day has made the bees eat most of their winter stores. It would be advisable for the cottagers at once to begin to feed, for having had to examine a great many stocks this last fortnight, I find in most cases the supply is getting short, and breeding in earnest has commenced, and the young ones are hatching fast; and some of the young actually on the wing. This is, in my opinion, the best time to transfer from straw to the bar-frame hives, having done two this last week as an experiment. I find it will avoid chilled brood, which is one of the greatest enemies we have to contend against. My plan was as follows: I took the two hives into a warm room, and there transferred them; after getting them settled in the bar-frame hive I placed perforated zinc over the top of the frames and entrance, and then placed them outside till they clustered together and removed the zinc the following morning, and hardly a bee was lost. I consider it a most satisfactory result, seeing the bees are now coming home with pollen.—C. POLLARD, Bee Expert.

*Cairnie-by-Keith, N.B., 21st March.*—To-day the weather is cold and stormy, wind about due west. On the 19th inst. I examined most of my stocks, and a very pleasant revelation was made, viz. *every stock fed with candy* during the past four weeks contained an extraordinary quantity of brood, whilst those *without* candy had only a small patch. I have therefore come to the conclusion that candy is the *best* spring food, especially for stimulative feeding. I used it in the spring of 1875. I make it the same as Mr. Sandler; but I may state that it was Mr. Raitt, of Blairgowrie, who gave us the first lesson personally. Another thing I observe, viz. the candy is converted into liquid food and stored up; a strong stock will require nearly 2 lbs. in eight days.—A. COCKBURN.

*Ireland, Bray, 21st March.*—Having had the months of December and January unusually fine and very mild, February has been very wet, about 8 in. of rain having been registered near here. March has also been rather wet, with severe frost on 7th and 8th insts., the ther-



meter registering 24° on the morning of the 8th. As a natural consequence, I find many hives, examined for the first time on the 18th inst., with no brood further advanced than the egg, the weather having been too cold for stimulative feeding. This is later than in any of the three previous years, although the winter has been milder.—E. D. O., JUN.

Co. Donegal, Finn Valley, March 22.—The experience of the past winter has conclusively proved the superiority of the bar-frame hive over the straw skeps. In this district only a fourth of the stocks in straw skeps has survived, while the few persons who have their bees in frame-hives have had no losses of stocks whatever. I have had all my stocks in 'Finn Valley Twin Hives' (as described in Vol. XI., page 269), and they pulled through well, and are now strong in numbers, carrying in pollen in abundance every favourable day, which does not come often, as March has been very cold here, with bleak, piercing easterly and south-easterly winds.—Q. Q. Q.

## Queries and Replies.

QUERY No. 755.—(HUGH AVERY.)—1. *Mr. Hewitt's Hive*.—Is it necessary with double-walled hives of Mr. Hewitt's pattern to have broad shoulders to the frames, or, as Mr. Simmins says, are they becoming a thing of the past? 2. How must the 3-in. space at each end of the frames be preserved?—A. 1. No, it is not absolutely necessary to have broad shoulders, but unless they are used you will find the hive very much more difficult to make and manipulate. I demur to Mr. Simmins' statement that 'broad shoulders will be a thing of the past' (if he has said so); with them the frames can be pushed backwards and forwards *en bloc*, without crushing combs or bees. I have tried plain frames and seen others work them, and must say I consider them very slow handling. People have different ideas of what is 'quick'; I think three or four times the amount can be got through with broad shoulders, properly made. 2. As the frame ends do not project beyond the hive side, by running your hands down, after the quilt is on, you can feel if they are standing out of true, and push them right; for a journey, the 'frame fastener' keeps them in place. Mr. Abbott *undershoulders* his frames, which, in my opinion, is a very objectionable feature, and has prevented this valuable design of shoulder from becoming popular with some bee-keepers. If cut true, they will become the frame of the future.—JOHN HEWITT.

QUERY No. 756.—(T. S.) 1. *Obtaining Honey*.—With an equal number of bees, which will give the greatest amount of surplus honey, straw skeps with sections, skeps with glasses, skeps with caps of straw, or any other except bar-framed hives?—A. You would most likely, other conditions being equal, obtain most honey in caps of straw, but you would obtain nearly as much in sections, and in a far more saleable state. Glasses are the least suitable. 2. *Honey during First Year*.—Will an early 4-lb. swarm store any surplus honey in any of the before-mentioned hives during the first year?—A. An early swarm of 4 lbs., if fed for the first ten days until they have filled the hive with comb, will, if the weather is suitable, no doubt show a surplus of honey. 3. *Non-swarming System*.—Will a stock that has been kept on the non-swarming system the year previous give a swarm and fill a super as well?—A. A stock which has not swarmed in 1883 will have a queen at least two years old, and perhaps older, and consequently past her prime, therefore not likely to do much good this year. You had better request it.

QUERY No. 757.—(RECTOR.) *Propolis*.—Can you tell me the best method of removing propolis from frames, sections, glass, &c.? Is there an acid or anything which

will readily clean it off without injury to the bees?—A. According to Vauquelin propolis contains—wax, 14; resin, 57; acid, and other matters, 29, in the 100. The acid appears to be a mixture of gallic and benzoic acids. At this season propolis is brittle, and can be readily scraped off with a knife. Paraffin oil or spirits of wine will dissolve it; and if the frames, &c., are freely exposed to the air before being returned to the hive, no harm will be done.

QUERY No. 758.—(JOHN MAUER.)—1. *Dysentery*.—Is dysentery contagious after the following manner? A stock of mine affected with that disease died lately, leaving me four or five frames of honey. Can I, without danger of contracting the disease, give these to another stock?—A. It is an open question whether dysentery is contagious or not. Scrape the wood-work of the frames, and sponge combs and frames, getting them as clean as possible, with salicylic acid—Cowan's recipe. You may then give them to any healthy stock without fear of infection. 2. *Carniolans and Italians*.—What are the characteristics of the Italian and Carniolan queens? and which is the most profitable to cross with a black stock?—A. The Italian bee differs little in size from the black bee, but is more slender in shape. The three upper bands of the abdomen are of a rich golden yellow, and the under-side is also yellow, but not so bright. The workers have longer tongues than the black race. The Italians are more active, less inclined to sting, far more prolific, better honey-gatherers, and work earlier and later than the blacks. They can also extract the nectar from red clover, which the blacks cannot reach. In outward appearance the Carniolan bee is slightly longer than the Italian, and not so slender in shape. It is in fact a larger bee—probably, the largest domesticated bee. The entire body is of a rich dark brown, almost approaching to black. The golden rings of the Italian are wanting, but each rim of the abdomen is clearly marked by whitish-grey hair, which render it distinct from any other known race; and these hairs being longer and brighter than those of the Italian, give the bee a silvery-bright appearance which is very pleasing to the eye. Italian queens and drones vary considerably in colour, some being almost as dark as the English, and others as bright and golden almost as the wasp. But the Carniolan queens are more uniform in colour, being more like the darker Italians. They are of a lighter brown than the workers, and have the three upper bands of the abdomen, as well as the under-side, of a yellowish-bronze colour, so much so, indeed, that many suppose Carniolans to have sprung from Italians. The Carniolan queen is a larger bee, broader in the thorax, and especially in the upper part of the abdomen, than the Italian, or black queen. Many pronounce them to be equal to Italians in all good qualities—honey-gathering, fecundity, hardiness, &c.—and superior in gentleness of disposition. Their swarming propensity seems to be greater than that of any other race, arising, no doubt, from the unrivalled fertility of the queens. Their energy and activity are unsurpassed, they are more easily handled than others, never attacking the manipulator unless very roughly handled, they keep well to the combs when under inspection, and are easily shaken off for extracting. Our own experience, so far, enables us to endorse the above characteristics, and we hardly know which to place first—the golden Italians or the silver Carniolans. 3. *Timing*.—What is the best time for uniting either of the above-named queens?—A. The best time for inserting Italian or Carniolan queens is in May or June, after taking out an artificial swarm, when the deprived stock should be removed to a new stand, or locality, any queen-cells it may contain being removed, and the alien queen introduced at once, by means of a queen cage. In almost all cases twelve hours' confinement will be found sufficient. See Raynor's *Queen Introduction*, price 3d., supplied by Mr. Huckle.

## NOTICES TO CORRESPONDENTS &amp; INQUIRERS.

- F. J. McD.—1. *Supering*.—Your stock being as strong as you describe, may be supered when the fruit-blossoms open, and will almost certainly give you some sections.
2. *Transferring*.—If you follow the instructions given in books on bee-keeping, there is no reason why you should not succeed in transferring; but the operation will retard, at any rate, your chance of supers.
- J. BERRY.—1. Carniolan bees are gentle, handsome (to those that prefer quiet beauty), and they are good breeders. 2. The cells of Carniolans are the same size as those of the English black bees.
- G. H. DUGARD.—*Carniolan Bees*.—See our remarks on Carniolan bees, p. 110, and Query No. 758 (2).
- BEE-SWING.—*Earwigs*.—Earwigs are, we admit, 'a great nuisance'; they frequent hives for the sake of warmth. The best remedy against them is to have strong stocks and well-made hives, which will generally prevent them effecting a lodgment. We may leave to the bees the task of guarding the entrances to their hives against the too-frequent ingress of blue-bottles, flies, &c.
- G. A. R.—*Dysentery*.—We consider from the appearance of the bees and the discoloration of the paper, that the cause of death has been dysentery. This is often the result of late feeding, and of having unsealed honey in the cells. This food being taken by the bees ferments in their bodies, and is the cause of abdominal distension and dysentery, which frequently develops into foul brood.
- REV. C. WOOD.—*Drones*.—We do not believe that the usefulness of the drones ceases on the fertilization of the queen. We conceive that the drones are of great service in maintaining the heat of the hive, and in helping to evaporate the honey prior to its being sealed for winter use. There may be many occult services rendered by the drones in the summer months, which services evidently are completed by the time the 'cool weather sets in'; and if it were not so, the worker-bees would not, when that set time arrives, be so determinately desirous of getting rid of them. At the same time the practical bee-keeper has it quite in his power by the use of foundation to limit the number of the drones in his hives. 2. *Water for Bees*.—Water is a necessity for bees. But if there is a natural supply in the vicinity of hives, there need not be any artificial provision made for them. We should not apprehend there would be any danger of the bees drowning themselves in the pond to which they might resort. 3. *Honey and Syrup*.—The bees are not able by the imbibition of syrup and passing it through their stomachs to convert it into honey, though some chemical change does take place. Virtually it remains syrup even when it has been sealed over in the combs. 4. *Stings*.—The remedies for stings are very numerous, and from the effects they produce on different constitutions it is difficult to pronounce arbitrarily which is the best.
- J. A. PATINSON.—1. *Quilts*.—For the winter months, soft woollen, flannel, or felt, prepared specially for the purpose. For summer use, 'duck, alias 'bed-tick.' 2. *Thickness of Covering*.—Two thicknesses of felt, or three or four of flannel, for winter covering; for summer, any light material will answer. Many use enamelled cloth, with the smooth side downwards. 3. *Porches* are not necessary, but desirable. 4. *Propolising Dummies*.—Undoubtedly they will.
- P. EVERITT.—There is little doubt that some accident happened to your Ligurian queen last autumn, and that the queen raised by the bees has not had an opportunity of being fertilised, and consequently is now a drone-breeder. We would, under the circumstances, at once unite the Ligurian stock to the black,

taking means to cause the bees to mark their new location, and to alter the appearance of their former position.

- MONA.—1. *Salicylic Acid*.—Add 1 oz. of salicylic acid (which ought not to cost more than 1s. per oz.) to  $\frac{1}{2}$  gallon of water with some borax, without which the acid will not dissolve; of this solution add 2 oz. (four table-spoonfuls) to each 14 lbs. of sugar employed.
2. *Strawberry*.—This is a honey-yielding plant. 3. *Inventatory*.—Will 'Mona' kindly drop his *nom de plume*, and we shall then be in a position to give effect to his invitation?

HILLSIDE.—*Placing Sections*.—The 5 $\frac{1}{2}$  side goes next to the frames.

NOVICE.—There is nothing in the external appearance of your queens, dipped as they have been in solution of thymol, which can assist us in determining the cause of the death of the queens. During the past season they seem to have fulfilled fairly reasonable expectations. We are of opinion that they have been victims of encasement. It is not uncommon when, at they beginning of spring, the bees, desiring to commence work, endeavour to stimulate the queen, if she does not answer to the call, she is weighed in the balances, and, if found wanting in queenly virtues, she is summarily deposed.

J. GOFF, *Chichester*.—*Loss of Bees*.—From your description, without other particulars, your loss seems to have been caused by robbing, either by strong stocks belonging to a neighbour, or a free flight has taken place among your own bees. Reduce the size of the entrances so that only two bees can pass.

F. S.—*Glass Super*.—We should not advise the use of so large a glass as you show, which, when filled, would weigh 50 or 60 lbs. If you are bent upon using it, however, you cannot fix foundation in it, but you may fix pieces of clean comb, by warming the glass, pointing it in stripes with clean hot wax, and pressing the pieces of comb on to it while hot. Stand it upon a board, with holes or slits for the bees to enter by; and you may also, if you please, fit to it a bee-trap, to allow the exit of the bees, but not the entry of robbers.

Q. Q. Q.—1. *Colour of Hives*.—Your question as to colours of paints and wood stains is quite foreign to bee-keeping, and we must leave you to exercise your own taste and judgment. 2. *Twin-Hives*.—You cannot better your treatment, and your opinion that the four stocks keep each other mutually warm is correct.

O. W.—*Uncapping Cells*.—Spreading brood must only be practised on strong, i.e. populous colonies, otherwise chilled brood and various evils will undoubtedly follow. Do not separate the six frames, not even for inspection, but on a fine warm day remove the quilts, and, with a thin-bladed sharp knife, uncap a few cells above and beside the brood-nest. Do this every twelve or fourteen days until the middle of April, when, if the queen is not old and worn out, the six frames should be well covered with bees, and others may be given outside the brood-nest. Further on warm syrup may be given as stimulative. If you manipulate, and pull your frames about, the probability is that the bees will divide and finally perish, since it will be impossible for a small colony like yours to recover the heat when once lost by manipulation, and breeding will cease altogether, and the old bee dying off, the cluster will become gradually less until it disappears entirely. If there is no dysentery, or disease, and you follow the above advice, you may build them up to a strong colony by the middle of May—always supposing the queen to be good. There is no greater mistake in bee-culture than over-manipulating weak colonies in the spring months.

We are sorry that the demands on our space have obliged us to postpone numerous valuable communications, and several Replies to Queries.

# THE BRITISH BEE JOURNAL

Communications to the Editor to be addressed to 'STRAUGHMANS' PRINTING OFFICE, Tower Street, St. Martin's Lane, W.C.'

[No. 144. VOL. XII.]

APRIL 15, 1884.

[PUBLISHED FORTNIGHTLY.]

## Editorial, Notices, &c.

### PEEL TESTIMONIAL FUND.

The Baroness Burdett-Coutts, President of the British Beekeepers' Association, has notified to the Secretary that she will be pleased to give a donation of 50*l.* to the above Fund. Her Ladyship also expresses her hope that the Fund raised may be large and general, and so disposed as to stimulate bee-keeping, and prove to the usefulness of the British Beekeepers' Association throughout the United Kingdom.

It is very desirable that the Secretaries of those County Associations who are unable to be represented at the meeting to be held on the 13th inst. should communicate their views and suggestions for the collection and disposal of the Fund, to the Secretary of the B. B. K. A., in order that they may receive due consideration.

### IMPORTANT TO COUNTY ASSOCIATIONS.

A very important extension of the privileges accruing to County Beekeepers' Associations affiliated to the Central body, has been recommended by the Sub-committee on County Associations, and favourably received by the General Committee at their meeting on the 2nd inst. It is this: At present each County Association is invited to elect, at its Annual General Meeting, two representatives who shall attend the Quarterly Conferences of the Central Committee with County Associations and make known their views upon matters of kindred interest; thus, to borrow the words of the printed Instructions, which were drawn up in 1880, and should be in the hands of all county secretaries, '*promoting the special knowledge of bee-keeping by constant action.*' Several County Associations, such as Kent, Surrey, Herts, Lincolnshire, Essex, and Berkshire—counties lying adjacent to the Metropolis—have for some time past exercised this privilege, and sent representatives to the Quarterly Conferences, who have been of the greatest possible service in keeping up an *entente cordiale* between the mother and her daughters, between the Parent Association and the affiliated Associations which have sprung from

her. But the more distant counties have seldom sent representatives to these conferences; and from their neglect, in some cases, to have neglected to appoint them at all, possibly from not understanding their privileges clearly, but still more possibly from taking up the privilege as one which, in their reasoning, the distance from London, is useless and without value. Suggestions have from time to time appeared in the *Journal* tending to place Associations distant from London on the same footing with regard to their representatives as those situated in close proximity to London. A vote has been given that the expenses of the journeys of these representatives to London shall be defrayed from the funds of the County Associations, or that they shall be defrayed jointly by the Counties and the Central body; but, like most a *l'voce* given gratis, it has not been much regarded. Want of money has generally been the excuse, and the obstacle. Now, however, a suggestion is made which involves no expenditure of money on the one side or the other. It is proposed that each affiliated Association shall be required to appoint two representatives, as before, to attend the Quarterly Conferences; but it is proposed to make it clear to the County Associations that these representatives need not necessarily be compelled to take a journey to London from Cornwall, or Cumberland, or any other distant county in order to attend the Conferences. According to the proposed suggestion which will be discussed at the Quarterly Conference on the 16th of April, County Associations would be empowered to nominate either one or two representatives, *not necessarily being within the boundaries of the county*, who shall attend the Conferences and represent the views of their Association, just as a Member of the House of Commons represents the views of his constituents, or, at all events, of the majority of them. Thus, for instance, the secretary of—we will suppose—the East of Scotland Association, which is the most distant from the mother of any of her daughters, or some member of his committee, might have a friend, whose residence was permanently fixed in London, and to whom it would be little trouble to attend at 105 Jermy Street four times in the year, give his opinions on any measures under discussion, and make known the wishes or requirements of the members of the East of Scotland Association. He might be a solicitor, or a merchant, or a tradesman, living in London, but connected by birth or relationship with

the Association which he would represent. One would say that he ought to be a subscriber to, and therefore a member of, the distant Association, so as to give him an interest in its welfare; but this point had perhaps better be left for the County Associations themselves to determine. It may be urged, as an alternative to this suggestion, that distant County Associations can easily make known their wants and wishes through the medium of letters written by their secretary; but every one has noticed the impatience with which the reading of letters (especially if they be not few and far between) is received by a meeting assembled expressly for the oral discussion of some definite measure for which no great length of time can be allotted. A representative attending a meeting has also this advantage over a mere letter-writer, viz., that he hears the opinions of others before he approaches the question himself, and has the opportunity of hearing the objections made to his own views, as well as of answering those objections on the spot without the delay of a written correspondence. Whilst a distant secretary would be writing voluminous letters, the representatives would have well discussed the measure and settled it finally. From these and many other considerations, we are of opinion that the end aimed at in these Quarterly Conferences can only be attained by the personal attendance of representatives of some kind; and that, if representatives cannot be induced to journey to London four times in the year for the purpose of attending these Conferences, representatives may be found in London itself, or in its immediate neighbourhood, who would find it a pleasurable duty to take part in the discussions and contribute their quota to the spread of bee-keeping and bee-knowledge throughout the United Kingdom.

It may be a further consideration in the face of the great number of County Associations now established, or on the point of being formed, nearly forty in number, whether it would not be well to send only one representative from each County Association. If it were not possible in all cases to send two representatives to the Conferences, those who could send only one would be at a certain disadvantage, whilst the appearance of eighty representatives at a Conference might be considered too large a phalanx to afford a reasonable hope of any business being promptly and harmoniously concluded. If a county secretary can attend the Conference, he is of course the best representative of his Association, and no other is really required.

#### A PUBLIC OPINION IN THE BEE-KEEPING WORLD.

From the report of the proceedings of the Committee of the British Bee-Keepers' Association, at their meeting on the 2nd of April, it will be seen that, in accordance with the suggestions of the Sub-committee on the Examinations of Candidates for Experts' Certificates, it was resolved that third-class certificates be granted at local examinations in practical bee-keeping, conducted by examiners appointed by the Central Committee, in which

examinations no candidate shall be required to do any paper work, or to give any lecture on bee-keeping. The effect of this resolution, the details of which have still to be worked out, will be to give men who can neither read nor write, but who have a practical knowledge of the art of bee-keeping, an opportunity of gaining third-class certificates, which may enable them to rank as authorities, to a certain extent, on matters of practical bee-keeping amongst their fellow-men, and possibly to obtain better situations as gardeners, nurserymen, or managers of gentlemen's apiaries. This is exactly what our correspondent, 'Platelay,' contended for in the first instance, and we cannot but congratulate him on the success which his suggestions have met with. We think we may also congratulate the bee-keeping world generally on this manifestation of the existence of a public opinion in bee matters which finds expression in the columns of the *Bee Journal*. The *Bee Journal* is (as seems to be generally understood) open to all who have anything to say which will advance the spread of knowledge as to the most humane and most profitable management of bees, and be of benefit to all classes of bee-keepers in the United Kingdom. We are only too thankful to receive ideas and suggestions having these aims in view, and our correspondents will see from the resolution alluded to above, that these ideas and suggestions meet at headquarters with the consideration to which they are entitled. We wish to place as little restriction as possible upon our correspondents as to their style and manner of writing; we would only remind them that a certain censorship of the Press is as necessary in matters connected with bee-keeping as in other matters, and would suggest that they confine themselves to enunciating their own views and opinions as clearly as possible without attempting to throw discredit upon the views and opinions of others who think differently from them. It is an old adage in legal circles, 'Where you have no case, abuse the attorney on the other side.' 'Platelay' had too good a case in his hands for him to need to stoop to such an expedient; and we were therefore, in common with many others, pained to find him attempting to throw discredit upon those who had worked so hard in establishing and conducting these examinations for experts' certificates, by the use of such phrases as *stump lectures* and *examining*. Had it not been for the exertion of such friends of bee-keeping as Mr. T. W. Cowan, and the Rev. G. Raynor, H. Bligh, and E. Bartrum, the idea of the lower grade of experts would, in all probability, never have entered into 'Platelay's' mind. He would have known nothing whatever about experts, examinations, or certificates. We hope that he will make the *amende honorable* to these gentlemen, who are the last men to advocate or support any hollow or unreal system of examination; and when he has done this we feel sure that they will be inclined to shake him heartily by the hand, and to thank him for the suggestions to which they have been able to give effect.

We must remind our readers, however, that the resolution to grant these third-class certificates at

local examinations is only the first instalment of the labour of the Experts' Examination Sub-committee, and that we may expect shortly to hear of further improvements in the existing system of examination for certificates.

#### COUNTY ASSOCIATIONS.

Reports of several County Associations for the past year are to hand. We give a statement of the number of Members of each Association. The following is the list already received:—

ASSOCIATION.	MEMBERS.	ASSOCIATION.	MEMBERS.
Warwickshire	302	Hampshire	145
Sussex	301	East of Scotland	144
Kent	300	Leicestershire	127
Hertfordshire	295	Cardiganshire	121
Buckinghamshire	288	Berkshire	120
Norfolk	244	Northamptonshire	115
Staffordshire	215	Hertfordshire	112
Devonshire	198	Yorkshire	95
Wiltshire	190	Oxfordshire	82
Essex	186	Cambridge	81
Dorsetshire	177	Suffolk	81
Worcestershire	176	Herefordshire	72
Cheshire	170	Huntingdonshire	60
Derbyshire	170	Somerset	67
Cornwall	166	Shropshire	52
Surrey	160		

No reports or balance-sheets have been received from the Bedfordshire, Lancashire, and Lincolnshire Associations. The reports are now in the binders' hands, and will be issued to the County Secretaries in the course of a few days.

#### IMPORTANT.

We desire to call special attention to the closing of entries for bees, hives, honey, &c.

(1.) At the Bath and West of England, to be held at Maidstone. Entries close April 16th.

(2.) International Health Exhibition at South Kensington; list of articles proposed to be exhibited must be sent in previous to the 19th inst.

(3.) The Royal Agricultural Show at Shrewsbury and the Bligh Competition; entries close for these events on May 1st. See advertisement on the back page.

These exhibitions will form the leading features of the year. Manufacturers of appliances and producers of honey will therefore do well to make their entries as early as possible.

#### NOTICE.

A large number of subscriptions to the *Journal* expire with the present issue; the expiry is indicated in the usual way. Formerly the volume terminated with the April number; it now closes in December. We would therefore suggest that our Subscribers should renew their subscriptions to the end of the present year.

#### MIDDLESEX BEE-KEEPERS' ASSOCIATION.

Steps are being taken towards the formation of an Association for Middlesex. Mr. Fox Kenworthy, formerly Hon. Secretary of the British Bee-keepers' Association, has intimated his readiness to act as Hon. Secretary.

## BEE-KEEPERS AT HOME.

No. VI.—THE REV. H. R. PEEL, AT THORNTON HALL, IN BUCKINGHAMSHIRE.

(Continued from page 114.)

The idea of forming County Bee-keepers' Associations was originally broached by Mr. C. Tite, of Yeovil, and adopted by Mr. Griffin in Devonshire, Mr. Dunman in Dorsetshire, and Mr. Goffrey in Lincolnshire. To Mr. Peel, however, must be attributed the idea of connecting the County Associations with the Central or British Bee-keepers' Association, and by this agency teaching the art of bee-keeping to cottagers in the remotest corners of the United Kingdom. Mr. Peel saw at once the importance of teaching bee-keeping on some systematic plan and by concerted action, and also the facilities for so doing which the County Associations afforded. Mr. Peel tells us that in carrying out this idea he trusted very much to the perfectly legitimate rivalry which such a system of Associations would provoke in the different counties. To use his own words, "he thought it would put them on their mettle to keep a foremost place;" and the result has justified his expectations. It is certainly the ambition of each county to stand first in the list which appears in the *Journal* each year about this time giving the order of County Associations according to the number of their members.

Hertfordshire was the first Association formed after Mr. Peel becoming the Secretary of the British Bee-keepers' Association. Devonshire, Lincolnshire, Dorsetshire, and we think Shropshire, having been already established; and to form the Hertfordshire Association Mr. Peel, aided by Mr. Huckle, worked very hard. Mr. Frank Cheshire was engaged to give addresses at meetings held in all the chief towns of Hertfordshire, at which Mr. Peel explained the intention of the County Association, and the regulations which he proposed for its government. That his labour was not in vain is proved by the honourable place which Hertfordshire soon began to hold, and still maintains amongst the County Associations of England. But Mr. Peel did not rest content with founding an Association in the county in which he was then resident, either by personal visits or by correspondence. He penetrated into the greater number of the seventy-five counties which now boast of Bee-keepers' Associations, and animated them with the spirit and energy of which he was himself possessed.

In reading his paper on 'County Associations' in the year 1881, when there were in existence only eleven Associations, Mr. Peel was bold enough to venture upon a prophecy that in ten years from that time every county in England and Wales would have its own Bee-keepers' Association. If the rate of progression in the establishment of County Associations keeps anything like pace in the next seven years with that which has been seen in the last three years, Mr. Peel has a reasonable ground for hope that his prophecy will be fulfilled. That twenty-five Associations should have been formed in the last three years is no slight testimony to the appreciation of their usefulness by the bee-keepers of Great Britain. The example has also been imitated in Scotland and in Ireland, whilst in Great Britain itself the number of Associations seems likely to be considerably increased before the end of the present year.

The idea of experts and of experts' tours is also traceable to Mr. Peel. Soon after becoming Secretary he recommended the Committee of that date to engage Mr. S. J. Baldwin to accompany the first bee-tent, which was made in 1878 by Mr. Huckle, of King's Langley, on its educational tours, Mr. Baldwin proving himself a master in the art of explaining the mysteries of bee-keeping in a simple and popular style. Mr. Peel engaged

him to undertake a visitation of the apiaries of the members of the Hertfordshire Association, and subsequently recommended this method of imparting instruction and obtaining new members to the Secretaries of other County Associations.

By many little finishing touches, such as making the Presidents of County Associations *ex-officio* Vice-Presidents of the British, and arranging that they should give away the prizes in rotation at the Annual Metropolitan Exhibition, Mr. Peel has endeavoured to perfect the system of the County Associations. To Mr. Peel, also, the Association is indebted for the admission of its Exhibitions to the Shows of the Royal Agricultural Society of England, the Bath and West of England Society, and of the British Dairy Farmers' Association, which have tended so much to make its existence and objects more widely known. He was the first to give effect to many previous suggestions as to the holding of conversational meetings, and has never been absent except during a severe illness in 1881 from one of these gatherings. Retiring from the post of Hon. Secretary at the close of last year, and having been elected upon the Committee, he is now a member of the Sub-committee on Finance, and Chairman of the Sub-committee on County Associations, so that he is still able to advance that particular department to which he has already devoted so much of his time.

In the Poultry world Mr. Peel is almost as well known as in the Bee world as a breeder of dark or coloured Darkings, for which he takes prizes at the Crystal Palace, and other large Poultry Shows. He is a great advocate of incubators, and was the promoter of the Incubator Tournaments at Hemel Hempstead. In 1882, Mr. Peel supported the engineer who superintended these tournaments in the action for libel brought against Miss May Arnold, of Acton, who was found guilty on all the counts submitted to the jury by Mr. Justice Bonman. Miss Arnold's action in this matter, and the vacillating policy of the Poultry Club Committee, was the cause of Mr. Peel withdrawing his name from the Poultry Club and devoting himself more entirely to the interests of the Bee-keepers' Association.

Those who know Mr. Peel can well understand how regrettable to his character are hesitation and uncertainty, and can, therefore, appreciate the force of his reply to Mr. Willis, Q.C., in the course of this trial, which caused so much amusement in the Court.

Mr. Willis, Q.C.: 'The Committee of the Poultry Club came to the decision that they could not decide upon the merits of this case. Was this so?'

Mr. Peel: 'Yes.'

Mr. Willis, Q.C.: 'And it was in consequence of their decision that you withdrew your name from the Poultry Club?'

Mr. Peel: 'No, it was not in consequence of their decision, but of their indecision.'

This reply fairly brought down the house, and completely turned the tables on the cross-examiner.

What may be done by decision and energy is evidenced by the history of the British Bee-keepers' Association since Mr. Peel became its secretary. From being an obscure and almost unknown Society numbering scarcely thirty members, it is now as well known as any Association in the United Kingdom, and with its affiliated offshoots numbers over 5000 members. Every year adds to its efficiency and importance, and we believe that the British Bee-keepers' Association has a great future before it as a National Institution.

Nothing has perhaps so much contributed to place the British Bee-keepers' Association in its true position as the acquisition of the *Bee Journal* by Mr. Peel, who at the close of the year 1882 purchased the rights of proprietorship from Mr. C. N. Abbott, in order (as he said) 'that *Bee-keepers might have a Journal of their own, free from any trade interests, or bias of any kind.*'

We understand that Mr. Peel, who since 1873 had retired from all direct clerical duties and responsibilities, has lately volunteered to take charge of the parish of Thornton-cum-Nash in which he is residing, and which is placed in such unfortunate circumstances that no clergyman can be found to fill the vacancy caused by the sequestration of the benefice. The Bishop of Oxford, we are informed, has gratefully accepted Mr. Peel's offers, so that he will soon again be engaged in clerical duties, in the discharge of which he will, no doubt, show as much energy and determination to succeed as he has done in revivifying the British Bee-keepers' Association.

We heartily wish him success in the new and unpromising task which he has undertaken, and only hope that he will not forget the claims which the bee-keeping world has upon him in his devotion to the claims of the church and his parishioners.

## FOUL BROOD.

By T. W. COWAN.

As the question of foul brood is a very important one, and one that should be thoroughly discussed, I should like to make a few remarks on Mr. Simmins' paper, and on the discussion which took place after it was read at the last quarterly meeting. I was glad to find Mr. Simmins was in accord with myself and others, who have always maintained its dangerous character, and the precautions necessary to be taken against its spreading. All he says about disinfecting hives, apparatus, and hands cannot be dispensed with, and half measures are worse than no loss; but when he tells us that the *only method* of curing the disease is by destroying all the combs and brood, I am sorry I cannot agree with him. It seems to me that, in advising this, we are not making any advance in the science of bee-keeping, but going back to where we were years ago, when nothing was known as to the cause or cure of foul brood. I wonder what would be said of a medical man who, in the case of some infectious fever, were to recommend his patient to be removed to a new house, and have everything in the infected residence destroyed. Should we not consider this wasteful and unnecessary? but it would certainly save some trouble. Just in the same way I consider it most wasteful and extravagant to destroy brood and combs in a hive containing foul brood, because with our present knowledge of the disease we have the means of effectually curing it in a rational manner, and also of properly disinfecting the hive even without removal of the population, and, I think, at a very much less cost than would be involved in the wholesale destruction recommended. Where an individual has only a few hives and cost is of secondary consideration, it does not signify much whether he destroys combs and brood or no; but we cannot teach those who are trying to make an industry of bee-keeping to take such measures, for it would be next to ruin to them to do so. In the swarming season the combs and brood of a hive are much more valuable than the bees that are in the hive, and by removing them and making the bees start afresh a whole season is lost, and the pecuniary loss to the beekeeper is very great; whereas if he treats his bees in a rational manner, he may not only save combs and brood, but secure at the end of the season enough honey to pay for all the doctoring, and leave a nice profit besides.

I have had considerable experience with foul brood, and had it at a time when so much was known about it as there is now. I have tried every method of curing the disease, including the starvation method, and have no hesitation in saying that, up to the present time, there is no known remedy superior to the salicylic-acid treatment. I must say that I am living in a neighbourhood where foul brood is common, and that so confident am I of the power I have to cure the disease that I have not

hesitated to receive diseased stocks into my apiary for treatment. I have also infected my own stocks for the purpose of experiment. In no single instance have any of my other hives taken the disease, and this I attribute to my bees being always fed with syrup containing salicylic acid. Mr. Simmins allows the use of the acid in syrup as a 'preventive,' but the proportions he recommends are very vague. Now, when experimenting, I found salicylic acid was expensive, and endeavoured to find out certain proportions less than the doses recommended by Hilbert, which would be still effectual and thus considerably reduce the cost. My experiments resulted in the formula which has been published in the *British Bee-keepers' Guide Book*, and was given long before that book first appeared to any one who wrote to me on foul brood. The proportions are 1 oz. salicylic acid, 1 oz. soda borax, to 4 pints of water, and this solution is used for washing the hives and apparatus. Mr. Simmins says he has less a tea-spoonful of acid in a quart of boiling water, adding a little powder borax. Now, this no formula at all, as a tea-spoonful is an indefinite quantity, tea-spoons varying considerably in their dimensions, and one's own idea of what a tea-spoonful is may be very different to that of another, and may vary from a certain quantity to three times that quantity. "A little powder borax" is still more indefinite, and may consist of a quantity not sufficient for the purpose it is intended for, or, on the other hand, of such a quantity as would destroy altogether the effect of the acid. I think foul brood is much too serious a disease to trifle with; therefore when a formula is given it should be so clear that no mistake can be made.

Mr. Simmins is evidently not acquainted with the properties of salicylic acid and borax, or he would know that it is only in certain proportions that these are effectual. Salicylic acid does not dissolve freely in cold water, but by adding a certain proportion of soda borax it does so readily, but at the cost of a part of the acid, which we are prepared to sacrifice to obtain this solution; but after this point is attained every addition of borax destroys the acid until a point is reached when the bees do not remain a particle of salicylic acid in the solution, and it becomes useless. In the first instance acid is wasted by not being dissolved in the water; and in the second it is wasted by being destroyed. At will, then, find it seen that the formula given by Mr. Simmins is too vague to be of any value.

Mr. Simmins traces his cases of foul brood to neglected chilled brood, and comes to the conclusion that neglected chilled brood will in time create the disease. Although I believe that chilled brood is amongst the causes of foul brood, I entirely disagree with him that it will in time create the disease, or that it even can do so. He says in his case, 'The bees were not able to remove such a quantity' (of chilled brood), 'or perhaps only neglected a few cells, and the brood in time turned putrid, and thus started the fungoid growth of the disease.' I do not believe in spontaneous generation, and do not believe foul brood can break out in any district if the germs of the disease are not present in that district; and it is only if the disease germs are in the district that chilled brood can form a nucleus for the spread of the disease. Before Mr. Simmins removed to his present apiary he lived in a district where foul brood was not at all uncommon, and it may be that *micrococci* spores were in the air, or even in some of his hives, before these were in a fit condition to take the disease. He traces the disease in his case to extracting honey from brood combs, and concludes by saying that in some localities 'foul brood is rampant, being brought on by the unwise manner of extracting honey from combs containing brood.' This is no reason at all, for there are many apiaries where an extractor has never been used which have been completely demised by foul brood, whilst others where extracting is constantly going on have never had any disease. I always recommend novices to be very careful in handling combs not to chill

the brood, and also advise them not to extract honey from brood combs; but when a person becomes experienced he will be able to do both without any danger, and at a great profit to himself. I should rather be inclined to think that the disease germs were present in the neighbourhood, and when any of his hives became in a fit state to propagate the disease it very soon spread. I am quite sure that in a healthy district where the disease germs do not exist, foul brood could not originate spontaneously, however much chilled brood there may be. I have my own hives affected with foul brood where there had been no chilled brood; and, on the other hand, aparies perfectly free from it where large quantities of brood were chilled by incautiously spreading the brood in the spring.

With regard to the cure of the disease I have more faith in the feeding with salicylic acid in the syrup than in the starving process. I know instances when a nest withstanding the starving process, the disease had broken out again. Feeding with salicylic acid, according to Hilbert's process (see page 10, present volume), is so simple that it can be done in a few minutes without destruction of the combs or bees, and without even any interruption of the work of the bees. It is perfectly effectual, as the vapour of the acid penetrates every brood-cell, crevice, and even every part of the body of the bee; and it is supplemented by feeding with syrup containing the acid in proper proportions, a recurrence of the disease is prevented. I quite agree with Mr. Simmins that every precaution should be taken against its spreading, and everything in use, including hands, should be washed with salicylic solution after visiting every hive.

In the discussion which followed the reading of Mr. Simmins' paper Mr. Zebitman gave his experience with two or three hives having foul brood, and declares salicylic acid because he has not been successful with it. He does not say how he used the remedy, or what precautions he took, if any were taken, to prevent the disease returning. So many cases are known of whole apiaries being cured by salicylic acid when the proper precautions had been taken, that one is inclined to suggest that everything had not been done which could have been done in Mr. Zebitman's case. He recommends thymol, but this is disagreeable to the bees, and if used in sufficient quantity to act as a disinfectant and poison to them, and it cannot be given them in their food. If it is used for disinfecting hives, these should not be used until free from the smell. There is not the difficulty of curing foul brood by means of thymol that Mr. Hinton suggests; the cuppings of brood being porous, the fumes of salicylic acid penetrate readily, and, without in the least affecting the brood, destroy all the disease germs. Thymol may be more antiseptic than salicylic acid, but it is much more dangerous to use, and even by Mr. Zebitman's recommendation must be supplemented by spraying with salicylic acid. If we wish to encourage bee-keeping we must give simple remedies for the cure of foul brood; and fortunately we have in salicylic acid a sure and simple remedy which has been found to be reliable if proper precautions are taken. Even the bee-keeper of the dangerous character of the disease and the proper precautions to take, and then we may hope to be free from foul brood.

## ASSOCIATIONS.

### BRITISH BEE-KEEPERS' ASSOCIATION.

A Committee Meeting was held at 105 Jernyn Street on Wednesday, April 2nd. Present, Rev. H. R. Peck, in the chair; the Rev. E. Bartrum, Hon. and Rev. H. Bligh, Rev. F. G. Jenyns, Rev. F. S. Selater, Captain

Bush, R.N., Captain Campbell, R.N., J. M. Hooker, H. Jonas, D. Stewart, W. O'B. Glennie (Treasurer), and the Secretary.

The minutes of the last meeting were read, confirmed, and signed. Mr. Stewart reported, on behalf of the Exhibition Sub-committee, that the arrangements for the B. E. Department of the International Health Exhibition were making satisfactory progress; an increase of space had been promised by the Executive, and a code of rules for its management had also been prepared.

The Sub-committee appointed to consider arrangements for holding local examinations for third-class certificates presented their report. The same having been considered, it was resolved, 'That, independently of the Metropolitan Examinations, third-class certificates may be granted after practical examinations to be held at suitable centres to be named by the Secretaries of the County Associations, and approved by the Committee of the B. B. K. A. The candidates will not be required to give a lecture or to answer questions in writing. The Examiner to be appointed by the Committee of the British Bee-keepers' Association. One month's notice (at least) to be given previous to the date of the proposed examination. The railway and personal expenses of the Examiners to be paid by the County Associations. The Examiner's fee and other expenses to be defrayed by the British Bee-keepers' Association; such examinations to be considered as part of the privileges afforded by the B. B. K. A. to the County Affiliated Associations, provided they have fulfilled the conditions of such affiliation. The Committee suggested the annual county shows as the most suitable centres for holding these examinations, when the judge (if appointed by the B. B. K. A.) could act as Examiner.'

The Sub-committee appointed for County Association business presented their report, proposing some useful amendments for the improvement of the rules of affiliation. The Sub-committee considered it very desirable that County Secretaries should make known through their District Secretaries the rules of the B. B. K. A. competition, and invite those who are qualified to enter for the competition. They also recommended that, as reports have been received from the whole of the County Associations except Bedfordshire, Lancashire, and Lincolnshire, the volumes be bound up and issued forthwith. The report was received and adopted unanimously.

**OMISSION.**—Our report of the proceedings of the British Bee-keepers' Association Committee Meeting held on March 19th, published in our last issue, omitted to state, 'That a special vote of thanks was accorded to the Hampshire Association for a donation of 5*l.* in recognition of the many and great services rendered to the bee-keeping cause by the British Bee-keepers' Association.'

#### COUNTY ARMAGH BEE-KEEPERS' ASSOCIATION.

The third Annual General Meeting of the County Armagh Bee-keepers' Association was held in Portadown on Tuesday, the 1st of April. The Rev. Hugh Edgar-Aghavilly, Armagh, in the chair. The Secretary read the following report of the Committee:—

'In spite of the unfavourable season which we have just passed through, we are happy to be able to tell you that the funds of your society are now in a most flourishing condition. The yield of honey in this part of the country was so small that your committee were of opinion that it would be better not to hold any exhibition. Accordingly the efforts of the society were confined to the circulation of the *Bee Journal* and the working of the Bee tent. The result of the season, due to Mr. Lett's untiring efforts, is that the bee-tent is now free of debt, and has earned for the society 3*l.* 9*s.* 6*d.*

It was exhibited at Banbridge, Newry, Armagh, Warrenpoint, Strabane, and Cookstown, and its gross earnings were 11*l.* 5*s.* 6*d.* The tent and its fittings are in perfect repair, and are worth about 20*l.*, and we may fairly estimate that it will produce for the society about 10*l.* a-year. The circulation of the *Journal* has not been so successful; we have seven copies in circulation, but members are so careless about forwarding it that many do not derive the benefit from it which they might have a right to expect. We would most strongly urge on our members the necessity they are under to forward it to the next name on their list without delay. Our treasurer, Mr. Richardson, has been obliged to go abroad, so that we cannot present you with a statement of our accounts, but in addition to the money in his hands I have a balance with which to begin the coming season of 4*l.* 4*s.* 6*d.* Now that the tent is the property of the Association Mr. Lett and I would most urgently beg of some assistance in working it. It is a great tax on our time, which is very fully occupied, and a very little help would lighten our work. One day in the year from four or five members would enable us to do a great deal. There are numerous parts of the county where it has never been seen, and the impossibility of giving time to attend to it has alone prevented us from doubling the number of our exhibitors. We enter the coming season with every prospect of success, and if the weather only be profitable we have no doubt but we shall do well.—G. GREENE; H. LEET, *Hon. Secretary.*

The Rev. H. W. Lett was appointed Treasurer of the Association; and a hive was balloted for, and won by Mr. Edgar. It was resolved to offer prizes for hives and bee-appliances of Irish construction, to be competed for at the N. E. Agricultural Society's Show, if that Society consented. It was also resolved to found a library of bee-literature, from which members of the Association could borrow books. The Association now numbers about eighty members.

#### RUDIMENTS OF BEE-KEEPING.

##### FEEDING AND FEEDERS.

(Continued from p. 96.)

The great object to be aimed at in spring feeding is to give a gradual constant supply, which must increase in quantity as the strength of the stock increases. Care must be taken that the brood-combs do not become blocked by an excessive amount of syrup, and that room remains for the desired increase of brood. At the same time, an insufficient amount of syrup will fail to produce the desired effect of rapidly stimulating the hive. Consequently, judgment and careful watching are necessary to hit the right quantity. When honey begins to become plentiful, feeding regularly becomes unnecessary, but even in the height of the honey season it is desirable often, when an unfavourable time sets in, to remove supers and replace them with the feeding-bottle. The object thus aimed at is to keep up the requisite production of brood in the hive, which otherwise might become diminished by the failure to gather honey during the bad weather. The moment the weather becomes favourable, remove the feeder and replace the super. Such a plan is in all ways advantageous, since supers in bad weather are liable to lose weight by honey being taken from them for use in the hive below. It is far better to keep your honey safe, and supply what food is required in the form of syrup. If the weather prove very cold, it may be found that the bees will not readily take the syrup. In this case it is desirable to replace liquid food by pea-meal candy, until warmer weather returns.

For the production of brood, pollen is largely used by the bees, and bee-keepers artificially supply this early in the season, before a natural supply can be obtained in



sufficient quantity. Pea-meal is usually considered the best substitute, and this should be supplied to the bees in a sunny spot, near their hives. If they want it, they will readily take it when once discovered. A little honey placed with it at first will attract them to the spot. The meal should be sprinkled over wooden shavings, or some other substance, to assist them in collecting it.

A syring feeder, to be a satisfactory one, must be capable of giving a small constant supply, and at the same time admit of the quantity being increased as more food is required. The usual feeder is well known, and consists merely of a bottle with a close-fitting zinc cap. In this cap small holes are made in a semi-circle, which, when the bottle is turned upside down, enables the bees to suck down the syrup without its running down into the hive. The capped bottle fits into a feeding-stage, made of two pieces of wood, with a piece of zinc between them. Each piece of wood should be about  $\frac{1}{2}$  of an inch thick, and have a circle in the centre cut out of it, sufficient to allow the cap of the bottle to fit down closely against the zinc sheet in the centre. A semi-circular slit,  $\frac{1}{2}$  of an inch wide, and corresponding exactly with the holes made in the zinc cap, enables the bee-keeper to make use of as many holes as he desires, leaving the others shut off from the bees by the portion of the zinc sheet which has no slit. By revolving the bottle on its stage more or fewer holes can be brought into use, and the quantity of food given made to suit the requirements of the moment. Feeders to work satisfactorily must have their caps well made, and close-fitting. A piece of cork inside the metal rim will much assist in making the cap fit satisfactorily, and a little grease on the cork will also be of use. Another form of feeder, much liked by the writer, is one made of a piece of glass tube  $\frac{1}{2}$  of an inch in diameter, which, if held over a spirit-lamp, can be melted in the centre, and drawn out to a point. Whilst being melted, it should be kept revolving slowly, so as to heat all sides equally. A small hole will be left (or can be made) of the desired size in each end of the tube thus divided. The tube thus prepared is fitted into the cork of a suitable bottle, which, if hollowed out around the tube on its inner side, enables wax to be melted into it, and an airtight joint to be made. The tubes can be of any desired length. One from three to five inches is a suitable size, as it brings the syrup towards the centre of the frames, and the syrup in the tube becomes heated by the warmth of the hive before it reaches the bees taking it below. This form of feeder simply requires a small slit made in the quilt, and does not need a stage. — F. S. SOLAYER.

(To be continued.)

**BEES AND BEE-KEEPING.** On Thursday evening, March 27th, an instructive and highly interesting lecture on the above subject was given in the National school-room, Ross, by Mr. A. Watkins, hon. secretary of the Herefordshire Bee-keepers' Association. The chair was occupied by the Rev. R. H. Cudbold, but the attendance was very moderate, although those present were apparently deeply interested in the subject. The lecture was illustrated by lantern photographs (all taken by the lecturer himself), and diagrams, which were ably shown by Thos. Blake, Esq. The lecturer briefly touched upon the antiquity of bee-keeping in this county, quoting from the Doomsday Book to show that at Wilton and Linton certain land was held by payment of a stated quantity of honey, and lambs, &c., per annum. He also pointed out that the honey produced was sufficiently valuable at a very early date to make the services of bee-keepers necessary. He then proceeded to sketch the new principles of modern bee-keeping, and touched upon the profits which could be easily realised by cottagers and others by the aid of these industrious insects. A description of the skeps, and the bar-frame hive, followed, together with the simplest methods of feeding

and managing bees economically and successfully. He cautioned his hearers against the adoption of the bar hive in preference to the skep, unless they also attended properly to the management of the bees, as left to themselves, bees would do better in skeps than in bar-hives, but with proper management the latter were of course more profitable. All straw hives should be flat-topped, and made a little larger than those generally in use, and the tops should be furnished with a hole for supering and feeding. Mr. Watkins mentioned that on no other insect or animal had so many books been written as on the honey bee, while he was pleased to say one of the most valuable was the work of a Herefordshire man, Dr. Bevan, who for some time resided at Hereford, and also in the neighbourhood of Ross. For cottagers he recommended *Modern Bee-keeping*, a sixpenny hand-book issued by the British Bee-keepers' Association. The harvesting of honey was also touched upon by the lecturer, and the method of driving, uniting, and manipulating bees generally explained.

**LECTURE ON BEES AT BRADWELL-ON-SPA, ESSEX.**—A most interesting and instructive lecture on "Bees and Bee-keeping" was given in the school-room by Mr. E. Durrant, of the Essex Bee-keepers' Association. The room was crowded, many people attending from the surrounding villages. Mr. Durrant described the great use of the bees in fertilising our fields and gardens, and gave a most interesting account of the inhabitants of a hive and of their habits. He referred to the cruelty of burning the bees, and pointed out that this not only involved a great loss of bees, but also that the honey was greatly deteriorated by the fumes of the sulphur. Perhaps the most interesting part of the lecture was that in which the different forms of hives were explained, specimens of each being shown, and the operations of open and close driving illustrated. At the conclusion of the lecture Mr. Durrant explained the objects of the Essex Bee-keepers' Association, and the benefits which were secured by persons who became members. He also gave in tabular form the amounts which different people had made out of their bees, and assured those engaged present that with a little trouble and patience there was no reason why they should not be able to pay the rent of their cottages by their bees. The above will make the seventh lecture delivered since Christmas by the Hon. Sec., Mr. G. H. Aubrey, and Mr. Durrant in different parts of the county. A great deal of interest is taken in these lectures, and we think they are doing good; they have been held at the following places this year: Gallywood, Danbury, Bradwell, Little Baddow, Rocking, to be followed during the next few days at Tapscott and East Hemmingfield.

## Correspondence.

\* \* \* All Correspondents forwarding Letters for insertion in the Journal, Reports of Associations, Shows, Meetings, Echoes from the Bees, Queries, &c., are requested to direct their communications to "The Editor of the British Bee Journal," c/o Messrs. Stracey & Sons, Tower Street, Upper St. Martin's Lane, W.C.

### EXAMINING HIVES. — A WORD OF CAUTION.

May I point out to over-zealous bee-keepers the vast amount of damage they unwittingly do their stocks by needlessly examining their hives and pulling their combs about? The present is the great breeding time with the bees of the successful bee-keepers; it is important to remember that brood can only be hatched in about 80° Fahr. in the brood-nest. The bees of themselves will not attempt raising brood beyond their ability to keep up to that temperature by clustering on it; consequently, to break up a small cluster, by dividing the patch of brood in the centre of the nest, by inserting an empty comb, or, worse still, a sheet of foundation, is the most fatal

mistake one can be guilty of. Under proper conditions, brood may be divided with most successful results, but first let me caution any one from attempting it unless the combs are crowded with bees. The young bees that are already hatched this year have a vigorous life to expend; but remember, the old bees still alive from last autumn are now dying by thousands, especially on days when cold winds accompany bright sunshine, and you may be surprised by finding the population of your hives dwindling when you most expected them to be on the increase.

The next thing I would note is examining the condition of your hives; do so as little as possible, not more than once a fortnight, except some special hive for some specific purpose; and do not jiffy shove into the flight-hole, for this reason: the bees will not suffer it in their hives, as soon as they have disgorged they will fan it out, and in doing so reduce the temperature. In examining a hive, anticipate your probable wants, and have everything ready to hand, so as not to keep the quilts off longer than necessary. Having removed all extra quilts, roll the one next the frames carefully back, so as to expose the full length of the first bar, puffing smoke slightly to keep the bees down. *Do not take a frame out unless absolutely necessary*; you can ascertain the quantity of brood there is sealed by sliding the frames back, and looking down between them, driving the bees aside, if necessary, with just one puff of smoke. If you think it advisable to divide the brood by inserting an outside frame in the middle, do so, and close the whole lot up again in a few seconds. I am not in the habit of 'rushing' through my hives, nor do I recommend it, but what I want to point out is the amount of mischief caused by uncovering a hive at this time of the year, say for three or five minutes. You will probably find it will take the bees a week to restore it to the original temperature. So be wise, and never remove the quilt quite off, and only roll it back from as many frames as positively needful. I have had but one sting this year, and that in the face from a wandering bee, when I was not examining the hives; and I am certain I do not use one-tenth the quantity of smoke I did when first I commenced bee-keeping, and, I may add, my bees are all black, I have no gentle Liguarians, having discarded foreigners altogether.

A friend of mine told me in great concern, a few days since, he saw his bees pulling out quilts one morning. 'I cannot understand it,' said he; 'they had a bottle of containing syrup; they are brooding well, and have unsealed food in their combs.' 'You took the frames out the previous day to look at them?' 'Yes.' 'And in doing so you chilled the brood?' and he is no exception, as, unfortunately, there are many that follow the same fatal practice; so if your readers are tempted to do so, like Mr. Punch, I say 'Don't!'—AMATEUR EXPERT.

#### IRISH BEE-KEEPERS AND THE ASSOCIATION.

I am surprised to read on p. 119 what 'Hampshire Hog' says about Ireland. Till I saw 'H. H.'s' statement, 'that our Association spent some £02. in introducing bee-keeping into Ireland,' I was under the impression that the tour of the British Bee-keepers' Association's Tent, and Messrs. Abbott and Carr, paid its way very well. I would be glad of an authoritative statement of the exact facts. 'H. H.' is not quite correct in saying that his Association introduced bee-keeping, by which I presume he means bar-frame hives, into Ireland, for there was a fair number of bee-keepers in Down, Antrim, and Armagh counties who had been successful with a large number of bar-frame hives for several years previous to the time 'H. H.' alludes to. Most, if not all, of these hives are still in existence, and by their pattern show the north of Ireland did not make a bad

start. They are nearly all of the 'Woodbury' size, and were made at home. Irish bee-keepers will be surprised to hear 'H. H.' charges them with ingratitude for favours conferred by their English brethren, but I confess to not being able to see the force of the charge. Everybody that I have ever met, who had the privilege and pleasure of listening to and seeing Messrs. Abbott and Carr when in Ireland have always expressed themselves in terms of admiration for their proficiency and obliging demeanour in lecturing in the Tent. What does 'H. H.' want further? We cannot afford to buy English hives, that at the outset cost more than Irish made, and then pay from six to ten shillings each for freight. And we do not believe in laying out money on some of the unobtainable articles that after keeping shop for long in London find their way into our Irish shops, and there catch dust on the shelves. Why does your correspondent choose such an ugly name, reminding one of the Irish gentleman who helps to pay his own's rent?—H. W. LEER, M.A.

Mr. Huckle, the Secretary of the B. B. K. A., informs us that the total cost of the Irish Tour was £71. 6s. 8d.; the receipts from the Bee Tent amounted to £17. 0s. 6d.; leaving a deficit of £54. 6s. 2d., towards which the Baroness Duddell-Coutts contributed £27., and the Rev. H. R. P. £120.]

#### FOUR YEARS IN A BEE-HOUSE.

This is written for amateurs. In 1870 I had several skeps in the garden and very little honey, and that bad. As the bees were always stinging somebody or threatening to do so, which is quite as alarming, I determined to do away with them. At that time several of the cottagers kept bees, in fact the neighbourhood appeared full of bees. I have three avenues of large lime-trees, which, when they were in bloom, used to be one mass of bees; it used to be quite a sight, and these bees were popularly supposed to come for miles to gather the honey from those trees. But the agricultural labourer is changed. The good old lot died out, and we have now a shifting population, who find it too much trouble to do anything but drink pleasantly. Bees became scarce, the seasons got bad, and we had no fruit, lightly or wrongly this was attributed to the absence of bees. Thereupon I determined once again to start an apiary; and as I like to understand everything I undertake I made up my mind to look after them myself. But I did not know how to begin. The *British Bee Journal* was to me unknown, so I went to an apianist (or should I say hive-maker?) to supply me with the best hives. The best hives for my purpose were the Improved Cottage Bee Hives. Of all hives that ever I have seen these are the very worst for a beginner. No doubt an expert could make something of them; in fact, if you ever become skilled enough you can keep bees to advantage in anything.

However, in the autumn of 1878 I started with two of these hives and one stock of black bees. The bees were the only good part of the bargain. I have their descendants now, and they are the quietest bees I have got. In 1879 I soon found that I should learn nothing, and be able to do nothing, with these hives. I then again interviewed the same apianist. This time I was recommended a bar-frame hive with a swarm of Liguarians. I was delighted, and at the same time purchased an extractor to extract all the honey I was about to get. This extractor was an imitation, and a very bad one too, of the 'Little Wonder.' This hive was well made of straw and wood, with a straw crown-board and a space above the frames. This space, with the spaces left by the distance-pins, made the hive such a cold and uncomfortable dwelling that the queen died in the winter, and left me, as a legacy for my stupidity, a fertile worker. This is my only experience of a fertile worker. Here was a beginning that nearly made an ending of this

apary. However, I am very obstinate, and, by great good luck, I was invited to stay with a friend in Nottinghamshire who had a large apary. Among other hives he had twelve in a bee-house, which appeared so successful that I meant to do likewise. The hives my friend recommended were Hooker's with Abbott's broad-shouldered standard frames. He gave me the name of a maker who could make them well, but perhaps would not. As this was the only maker he knew of I wrote to him and ordered six hives. Well, he took nearly twelve months making them, and when they came they were all wrong. A nice job I had to make them right. In the meanwhile, as I could not get these hives, I wrote to Mr. Hooker to ask if he made them, or could recommend me some one who could. He replied that they were unsuited for a bee-house, and that he could not, and would not, make them for such a purpose. Here was a blow! However, my obstinacy could keep me going; and from my experience of those broad-shouldered hives, allow me to assure Mr. Hooker that his hives are, after the best for the purpose, I would improve them by placing the frame across, and making them into a combination hives of moderate length.

Now for the bee-house. I was already possessed of a bee-garden. In the middle of a ten-sided summer-house with a pagoda-like roof, I filled in the sides of this summer-house, leaving the north side for a door with zinc windows. The other sides were altered by fitted with shutters and window sills to open. All round was left an open space one foot wide about six inches above the ground. Just under the eaves was left another open space six inches wide. These spaces were filled in with lattice-work and perforated zinc. This keeps the temperature in winter much the same as outside, except for the protection from cold winds. In summer it is much cooler inside than out. When I open a hive I put a curtain over each window, and shutters over the perforated zinc. The door is then opened, and all the bees naturally fly to the light, and go out. An improvement would be to have revolving wind-ers in the door. It does sometimes happen in manipulating a hive of hybrids that they try to take possession of the house. These that go out collect other devils worse than themselves, and regularly storm the building; with revolving windows you would only let the bees out, and not in. When you are taking sections it is convenient to keep the door shut, and it is a nuisance to have to be always opening it to let the bees out. An amateur who has manipulated a vicious hive out of doors and one in a house, will never keep bees out of doors again. By the way, when I first began I read a great deal about bees not stinging. Don't they sting? In the summer they take possession of their own garden, and will often drive any one out of it, not protected with a veil. My goodness! how they sting when they swarm, more especially Ligurian! Hybrids are admitted to be the worst, but I find Ligurians worse than Blacks. A black bee makes a deal of fuss, and says, 'If you don't get out of the way I will sting;' but often thinks better of it and does not. A Ligurian pretends to be quite quiet, and thinking of nothing in particular, till he has spotted a tender place, and then he has his sting into you like a flash of gipsied lightning.' But I must get back to the bee-house. This bee-garden got its name from bees having been kept in it a hundred, and perhaps more, years ago, when a bee-house stood on the exact spot of the present one. I find this entry in Moses Rusden's *Further History of Bees*, 1679, 'Lady E., bee-mistress, and proprietor of many colonies managed on new principles. Thos. Edwards, assistant-general, 1788.' The frontispiece of this book is an illustration of a Stewarton hive. I have a collection of ten books on bees written between 1457 and 1796, all advocating the humane system of not killing the bees, yet with how little effect.

transferred the bees which I had collected in 1879

into the hives inside the bee-house in April, 1880. Having found so much difficulty in procuring Hooker's hives I ordered three of Abbott's Royal Standard Hives. These were now filled up the time sides. I can never get the side sections of the hives filled; for the matter of that, I never can get broad-sections at the back, so well or quickly filled as in a crate on the top. One of the many advantages of a Hooker is that you can always till the exact time to put on a super. As soon as, and not before, the bees cling to the glass all round the hive put on a super, and they go into it at once unless the weather turns bad. I never have any trouble in these hives with bees refusing to take to the supers. Having filled the house with all the hives I intended for it let us come to results:—

No.	1880.	Comb. Extracted		Total.
		lbs.	lbs.	
1.	English. Swarm from No. 1	—	7	7
2.	Ligurian. Stock from last year	—	—	—
3.	Hybrid. Swarm from No. 2. The queen was subsequently lost, and the hive became hybrid	—	23	23
4.	English. Stock from last year	12	1½	16½
5.	English. Stock from last year	—	6	6
6.	English. Swarm from No. 7	—	10½	10½
7.	Hybrid. Stock from last year. Was originally Ligurian, but must have been queen and become hybrid	38	11	49
8.	Ligurian. Swarm from last May	—	—	—
9.	Empty	—	—	—
Totals		50	62	112

1881.				
1.	English. Swarmed three times	43	34	77
2.	Ligurian. Swarmed once	39	—	39
3.	Hybrid. First swarm	49	—	69
4.	English. Swarmed once. Lost the queen, and on July 26 gave a frame of brood from No. 8. Must have mixed with Ligurian drone	11	2	16
5.	English. Swarmed six times	30	—	30
6.	Hybrid. Swarmed twice	50	—	50
7.	Hybrid. Swarmed once	65	—	65
8.	Ligurians. Swarmed twice	6	34	39
9.	Ligurians. Swarm from No. 8	6	7	15
Totals		355	74	431

1882.				
1.	English. Swarmed four times	—	8	8
2.	Ligurian. Swarmed three times	20½	7	27½
3.	Hybrid. Swarmed five times	—	3	3
4.	Ligurian. Lost a beautiful golden swarm, and so became hybrid	—	7½	7½
5.	English. Swarmed three times	—	1½	1½
6.	Hybrid. Swarmed twice	16½	2	18½
7.	Bought a Ligurian queen, which arrived in weak condition. Successfully introduced, but never did well. Eventually died in the autumn, and stock perished	—	15½	15½
8.	Hybrid. Swarmed once	25	5	30
9.	Ligurian. Swarmed four times	—	18	18
Totals		68	67½	135½

1883.				
1.	English. Swarmed twice	81	8	89
2.	Ligurian. Swarmed eleven times	41½	11	52½
3.	Hybrid. Swarmed three times	67	7½	74½
4.	Hybrid. Swarmed twice	51	9	60½
5.	English. Swarmed twice	80½	6	86½
6.	Hybrid. Did not swarm	66	14½	80½
7.	Empty	—	—	—
8.	Hybrid. Swarmed four times	86½	8	94½
9.	Ligurian. Swarmed twice	52½	36	88½
Totals		529½	100	629½

The swarms are all put back. Nothing will prevent swarming. I have tried cutting out queen-cells, and putting them back late in the evening. If a hive gets the swarming fever it will swarm whatever you do. Last year several swarms left the hives in which they were taken, and had to be hived again. I have not counted these occurrences. Swarming is the great drawback to bee-keeping. Think of the labour in hiving twenty-six swarms, the number for 1883. In 1882 a large swarm left No. 4 early on a Sunday morning. I found it on the top of a high pear-tree, shining bright gold in the sun. No one was about, and while I was gone for a ladder the swarm departed, and where I never could discover. There is a peculiarity about No. 3, that every autumn it dwindles down till in the spring there are not enough bees to completely cover two combs, and yet when they begin they increase most rapidly. I find the greatest difficulty in selling the honey. However, in 1881 I was able to devote to charity the sum of 16*l.* 11*s.* 2*d.*, and in 1883 the sum of 25*l.* 9*s.* 6*d.* There is one curious fact, and that is, that since I began there has not been one year in which there has been honey in the hives. There has been no honey collected after the first fortnight in July; the honey harvest practically ends with the end of June. The number of pounds in 1883 were ascertained by careful weighing and allowing for the weight of the wood. No sections held the amount they are supposed to.—G. C. E.

#### PLANTING FOR BEES.

Several correspondents have recently taken extreme views on this subject, but the facts of the case seem to be these. There are very many bee-keepers who have but a limited area, and want to know whether it is desirable to plant or not; and if so, what will give the best results in his particular case? This class of bee-keepers cannot afford to experiment with all the many varieties that they are told the bees are fond of. There are a great many so-called bee-plants that are found really useless when brought under the test of careful observation, while others that are good for the short time they last do not pay for the ground occupied, when it is considered that other kinds, even if slightly inferior, lasting many weeks longer, give more honey or pollen for the time and space taken up in their culture. It shall therefore be my endeavour to point out two or three kinds only which experience has proved to me to be among the best, not only for the large daily supply they give, but also because of the long time they continue to flower.

Though it is true that little good is done to bee-keepers in general by giving the names of the many plants bees are found to visit, the best varieties would never be brought to light were there not some who devote their time and labour to experiments on every thing that seems at all likely to be of use.

Will bee-pasturage pay with a small garden? Well, if you want to grow your own vegetables, it will pay you far better to leave bee-plants alone, with the exception of fruit trees, which most gardens already possess to a greater or less degree. But if you do not care to have a kitchen-garden, or are willing to devote part of it to bees, have as many black-currant trees as you can, and wall-flowers in every available place. The latter give an immense quantity of early pollen and some honey, while I have found no fruit tree so valuable for bees as the black currant. With a number of trees the bloom lasts nearly six weeks, and the shape of the flower is such as to enable the bees to collect all the honey produced; being bell-shaped and hanging downwards, nothing is lost either by wet or evaporation. The bees are busy on this tree from early morning to dusk, and considering the long time it keeps flowering, it may be placed nearly at the head of the list as a honey-bearing tree. Neverthe-

less you will be grievously mistaken if you expect your small crop to give you a surplus of honey. All you can do will be to add to the little of others around you at the most critical time, when it is desirable to 'stimulate' your bees to greater activity that they may be in readiness for the larger crops further off when the opportunity offers.

Those who have a few acres would do well to plant nearly the whole with black currants and raspberries, thus obtaining a crop of fruit besides the honey. Wall-flowers should be planted in most of the remaining space, and between the rows of trees and canes for the first few years until the latter are well grown. Leave about quarter of an acre for mustard or mignonette, both of which will give large quantities of pollen, to aid the feeder when it is desirable to obtain young bees in autumn. Half-an-acre of wall-flowers will supply sufficient pollen, close at home and just at the right time in spring, for more than a hundred colonies for weeks in succession; and on very many days when thousands would be lost by going further, nearly all the working force would occupy themselves on this home crop during each bright spell of sunshine. Mustard sown towards the end of August will last in flower until frost, but if put in earlier, it will go off in five or six weeks from sowing, especially if at all dry.

With limited space, therefore, we can do little more than aid the sugar-feeder, though in the production of pollen a small piece of ground can be made to give all we may want early or late, when the bees should not be forced to take long flights.

Many advocate the crocus for early pollen, and certainly it is very early, but from careful observation I am convinced that it yields little honey, and pollen only at the expense of great time and labour. On a bed of some 5000 I noticed, even on warm days, comparatively few bees, while I was surprised at the length of time it took them to load. A dozen loads can be obtained from wall-flowers while one is secured from crocuses, and therefore I have come to the conclusion that the latter do not pay for the ground they occupy if grown alone. They last barely a month, while wall-flowers, which are quite early enough, continue in flower for many weeks. The only profitable way to grow crocuses is to plant the bulbs rather close, and then sow white clover (and lawn grass) over them. Each year they will then come through and flower before the clover makes a start; and as soon as the latter begins to go off the scythe must be put in, and then another crop of clover-bloom will soon come on, making three crops a-year with little labour. The first cutting will be made late enough to give the crocuses a good growth after flowering, and little harm will be done to the new bulbs.

Again, if you grow wall-flowers, *Arabis alpina*, and many others flowering at the same time, and generally considered excellent bee-plants, will receive but little attention, as the bees work almost exclusively upon the first mentioned, and therefore the hint should be taken.

The farmer with his many acres has great advantages, he can in several instances obtain two crops a year for both honey and hay, and knows well what is best adapted to his own purposes. Nevertheless he cannot afford to omit some special crop such as already mentioned to come into flower earlier than his usual farm produce.

The bee-keeper, too, who is not a farmer must look about and see what his neighbours are growing around him, and also observe what other natural honey sources his bees may have access to, or he will be working without any definite object in view and will never be ready at the right time.

I am convinced that planting for bees has paid myself and well too, and consider that all those who are unskilful or unwilling, to study the subject unless they have great natural resources, will be far in the background.—SAS SIMMONS.

## COUNTY EXPERTS.

When I wrote in the *B. B. J.* of March 1st, under the article 'Lower Grade of Experts,' I was quite ignorant of the required proficiency of the third-class certificate. I am glad to learn from the Rev. G. Raynor that 'it is most easily within the reach of the gardener, the groom, or the intelligent cottager'—of course distance is not alluded to. Would it not assist the candidate for a certificate if the past questions were published? It would give him some idea of the proficiency required. This system is adopted, I believe, in most Government examinations.

I envy happy 'Hodge,' his third class being so easily within his reach. I fondly hoped, with a fair knowledge of the *modern* history of apiculture, the physiology of the bee, and the various systems of bee-keeping, together with a good many years' practical experience, I might aspire to a first class. But since the text-books include Aristotle and other ancient authors in the ancient languages of Greece and Rome, and a history of the science for more than two thousand years back, my fond hopes vanish into thin air. Mr. Raynor does not think that a S. Athenian would find much difficulty in making himself understood in the Cumberland dales (the river Wear is in Durham). My experience with friends from the South who have visited me here is very different.

As regards intercourse with the labouring class, Mr. Raynor thinks his experience differs from mine. He will pardon me for a seeming contradiction, but I don't think it does; I am intimate with every person in the place, and when I meet them in their own houses or gardens there is not the slightest reserve or timidity between us. When they see me manipulating in my apiary they will come to me and inspect everything, and gladly receive my instruction. If a still, if they want any advice on hive-making or anything else they invariably go to one of their own class, notwithstanding I have repeatedly offered to instruct them, either in my workshop or among my bees. This is what I mean when I say: 'They don't *consult* a duffer with me.' My experience is of Durham and Nottinghamshire. *LEWIS, Weardale.*

## RAISING QUEENS.

The time is fast approaching when many amateurs will be raising a few Ligurian queens. Generally find the most successful beekeeper is the one who can vary his mode of operations according to circumstances. Mr. Cowan's advice is valuable, being the result of considerable thought and experience; but where a person has only one Ligurian stock, to lose the queen, as Mr. Bellairs did last year, is not only annoying, but difficult to replace such a queen at that time of the year. I reared several queens last year, varying my plan of operations according to circumstances. In giving my method of procedure, I wish it to be understood I do so simply to assist amateurs.

1st. In the early spring I stimulate one strong English stock and two Ligurians, one for queens and the other for drones. When sufficiently forward, I take away the queen and the unsealed brood and eggs from the English stock and insert a frame containing eggs only from the Ligurian stock selected for queens; thus I get my queens without disturbing the queen at the head of the Ligurian stock. 2nd. Took away queen from strong English stock and allowed them to start queen-cells, then transpose eggs from the best Ligurian stock to the queen-cells in the English stock. I succeeded well with this plan last year. 3rd. One nucleus stock lost their queen on her wedding trip. Finding the cell from which she was hatched not more than half eaten away, I transferred a Ligurian egg to the old cell; the bees forthwith supplied it with royal jelly and hatched one of the best queens I reared last year; she is now at the head of a

strong colony. The method of forming nuclei is so well known that it would be waste of time to go over that ground. If I have the opportunity I intend trying other modes this year; if successful, I will give particulars in *Journal*.—L. WREN, *Lowestoft.*

## SIZE OF SECTION.

Now that the British Bee-keepers' Association has done so much for beekeepers in fixing a standard frame, I write to call attention to the perplexing variety of sizes of sections; one well-known manufacturer of bee-appliances advertising no less than seven different sizes, which even go to small fractions of an inch in size. But this is not all; let me take an instance; a thinking man starting bee-keeping, looks the list over and comes to the conclusion that 4 x 4 is the most likely size to obtain in the future, and buys a lot, provides crates, uses them and orders more. When the new ones arrive he is dismayed to find that his crates are useless, for one lot stand with the 4-inch side vertically, the other the 4½ inches (the eggs—and inches slit being in the short side in one lot, and the long side in the other lot). Surely all this is unnecessary trouble. May we not reasonably expect this number 8 to be reduced to 2½ say one standard 1 lb., and one 2 lb. size? Take my own case; I want to make or buy a number of crates for this spring's use; it would be most vexatious to find these crates entirely superfluous in a twelve-month's time.

Will not some able beekeeper say a few words to advise beginners in the matter? Some may think that the difficulty would be obviated by always buying one's sections from the same dealer. This is not always convenient or economical, and would not hold good should one dealer deal in sizes not adapted locally. Summed up, but we want to know is, what are to be the exact dimensions of the standard 1 lb. and 2 lb. sections of the future; and whether, supposing them to be able, the 1 lb. sections should stand on their long or short side? R. E. C.

Similarity in bee-keeping appliances is desirable. The same perplexity that has troubled our correspondent has possessed itself to the Irish B. K. A. who have determined that no one-pound sections except the two sizes, 4 x 4 and 4 x 4½, should be exhibited at their coming show. The Americans prefer the 4 x 4 for the 1 lb., and 5 x 6 for the 2 lb. Perhaps the Committee of the B. B. K. A. would consider the desirability of fixing a standard size for sections.

## FIXING NEW COMB.

The summer before last I found that my new combs when covered with bees were rather inclined to break out of the frames when shaking the bees off. I therefore tried several things to obviate this, with varying success; and among others (at the suggestion of our expert) I fastened a narrow strip of wood on each side of the foundation, about half way down the frame, allowing the foundation to hang loose between them. Last year I had several of these combs worked out, and find that the bees fasten the comb tightly to the strips, and so render them quite safe. I found the above method such a complete success, that I think all beekeepers should give it a trial.—G. H. DUGAN, *Wylde Green.*

## DESTRUCTION OF EGGS.

I bought last October a Ligurian queen, which I placed in a bar-frame hive with a good supply of sealed honey, but no brood. After about a week I found eggs deposited in three frames; but on examination, about a week or ten days afterwards, I found there were neither eggs nor brood. In another bar-frame hive I found the

same thing took place in the outside frame, while the eggs laid in the inner ones were duly hatched. This latter occurred last spring, some time after the hatching had commenced.

Would you kindly say whether this is a common occurrence, or does it indicate something wrong with the hive? An answer to these queries in your next issue will oblige.—VALERIAN NOVITZKI, *Dundrooch, Pithlochry, Perthshire, N.B.*

[In the first case, the season was too late for brooding, hence, the eggs were destroyed by the bees. In the second, the vagrant propensities of the queen were checked by confinement to the brood-nest, and the eggs deposited in the outer combs were removed or devoured by the worker-bees. These are not uncommon occurrences, and they do not portend evil.—Ed.]

#### EARLY SWARM.

The early swarm reported at p. 122 as having been got at Stone, Staffordshire, cannot have been what is usually understood by a 'swarm.' It, in all likelihood, was a whole colony deserting their old hive, which was unfit for longer occupation, either from the combs being too old, or something unpleasant having come to pass amongst them. I have known several instances of such to happen with very old skeps, where the combs were quite black and the straw rotten and as wet as farm-yard manure. Unless the stock which gave off the reported 'early swarm' can be proved to have performed such a feat, I prefer my theory of wholesale emigration.—H. W. LARR, M.A.

#### CLUTTON'S FOUNDATION INSERTING MACHINE.

Every bee-keeper who uses frames with saw-scarf down the centre knows how difficult it is for one person to place the foundation therein, but did they know of a simple little article, invented, and, I believe, manufactured and sold, by Mr. S. F. Clutton, of Pressingfield, they would soon do as I did—obtain one, and find the difficulty turned into pleasure. These little machines open and hold the frame, leaving the operator's hands free to arrange the wax-sheet. Afterwards, by a simple arrangement, the frame is closed, and the 'insenter' continues to hold it firmly whilst a thread or wire is passed on either side of the sheet, to secure it straight. Persons with only a few hives would find it a great comfort, when a those with many could fill their frames with ease, accuracy, and despatch. As this seems to me to be quite a bee-keeper's find, I trust I may be allowed space to bear testimony to its usefulness.—M. E. BARKER, *Earsham, Bungay.*

#### DOUBLE HIVE.

My excuse for intruding this note into the pleasant pages of your *Journal* must be set down to the 'bee-mania' which has seized me like so many of your correspondents through reading them *con amore*. If I did not fear to trespass too far I should be glad to send you a description of a hive that I have constructed, but perhaps your readers are already sufficed with these suggestions?

I have put together a double-hive, the outer frame being an exact square of about 26 inches, so that by a peculiarly constructed floor-board I can reverse it (half face) without disturbing one insect. This simple contrivance, with two entrances in floor-board, will give me a combination of Messrs. Cowan, Abbott, and Neighbour's methods, and the chief advantages thereof. The hive, properly situated in the middle with three division-boards on Abbott's principle, will take sections

in the rear and in the two sides, the middle board stopping all draught and sunlight, aided by the peculiarly made floor-board. It will take sixteen frames on the Neighbour's plan; that is, frames parallel to front line, north and south, and a large space will be left in the rear for sections. It is evident that it can be used as a twin-hive when the frames run the other way, or to form nuclei. Feeding inside hive is also simplified, and it is large enough for Syrians. In either case, crates of sections can be placed on the top, and the wintering arrangements can be made almost perfect. I have made it all of 1-inch yellow pine. The top is simply a square, and my cover is, I think, worth describing more fully. I nail together, almost any way, a few stout boards, taking care only that the under side is quite flat. On two outer and opposite edges I screw two strips of wood, curved to the best shape I require, to run off the rain. I fill up with Portland cement, draw a straight-edge over curved strips; and I have a good cheap roof, waterproof and heavy enough to defy wind and weather. My strips project downwards also half an inch, and the whole is three inches larger than hive. The curved surface inclines to the sides, so the front is protected thus far by it.

Are apiarists right in giving so little ventilation? Last autumn I had two swarms in straw skeps laid by the garden on two narrow boxes on the ground; I could neatly insert my closed list in the open spaces. What was my surprise to find these two hives the strongest in my apiary, and wasps, then very numerous, afraid to attack these, and these only!

Also opposed to present theory, an Indian officer tells me that near Cabul he saw a large swarm, high in the air, and like a dense cloud; the men made a tremendous din with tin cans, and they came down into the camp as though they were shot.—UNGER, *Hortown Rectory, Weyford.*

#### QUEEN INTRODUCTION.

The Rev. G. Raynor takes me to task for not stating in so many words that I used smoke while introducing by my method. I am willing to admit that it would have been better, but my reasons for not doing so have already been stated. Mr. Raynor seems to have based his supposition that I used no smoke upon the fact, that I have stated I do not find it necessary to so thoroughly intimidate the bees as he would have us believe is desirable.

When remarking upon Mr. Raynor's statement, that 'if we act upon the principle of thoroughly intimidating the bees before the union is attempted, we shall not err far from the truth,' I believed then, and do so now, that he was referring to direct introduction, as, immediately following, he goes on to show how he without caging introduced queens to skeps by first driving the bees, and to bar-frame hives while the tenants were reduced to the same state of demoralisation by being shaken from the combs into a skep. But because I objected to so much needless labour, reducing the bees in frame-hives to such a helpless state, I cannot see why it should for a moment be supposed that no smoke was used in my own manipulations, especially as Mr. Raynor himself did not consider smoke sufficient to thoroughly intimidate without the additional drumming and shaking the bees from the combs while endeavouring to dispense with the cage.

Daily experience still further convinces me that the best results are to be obtained by 'as little disturbance as possible,' and that smoke used in moderate quantity as under ordinary manipulation does not thoroughly intimidate the bees, as is evinced by the queen frequently continuing her duties and the bees attending to her while the comb is held in the hand. Not so, however, with 'driven' bees or those in the same condition shaken from

the combs. These are so demoralised that they will neither protect themselves nor their queen, while the latter is continually trying to hid herself and is unnoticed by the frightened crowd. As I have myself shown, bees can be united under such conditions; but again, I say, I do not fit it necessary while introducing queens to frame-hives, nor when uniting bees in frames of the same size.

Again, nothing will disturb a queen more than being handled by the operator, and when in an un settled condition she simply invites an attack, even if she do not become the first to attack the bees, as is sometimes the case when in that state. This state of things I always avoid, and when my process is properly carried out, neither the queen nor the bees seem to be aware that they have fresh neighbours.

It is to be regretted that, through a very serious omission, Mr. RAYNE should have been led to conduct experiments in a wrong direction, causing him to harshly condemn a system which has proved invaluable not only to myself, but to very many others.

While on the subject of queen-triangles, I would caution the reader against a plan used by D. A. JONES, of Canada, and commented by the Rev. G. H. PERIN in his revised pamphlet. The method adopted is that of chloroforming the bees, and then perfuming the queen to run in the entrance. It is to be regretted that a devoted bee-keeper should thus acknowledge the inability to introduce a queen by some more reasonable plan, rather than resort to such practice. Now, supposing the brood does not get chilled, there are two other conditions induced by this process, that are likely to lead directly to *faul brood*. A drug, powerful enough to reduce the adult bees to a state of stupor, will not occasionally kill a large portion of the delicate larvae, some of which may escape, and at the same time give them a chance to easily remove it in time to prevent serious results. Next, if not while the sleeping bees shake the entrance, as soon as life begins to return to them, the state of self-entrapment caused by a strong odour, while in this condition is most detrimental to the brood; and this is one of the many agents in producing the dreaded disease. It is a remarkable fact that foul brood is abnormally common in America. Can it be that this recent mode of introduction has tended toward bringing on the malady? We cannot say for certain, but it is a strange coincidence, and bee-keepers should be warned in time. SAMUEL SIMMONS.

#### 'EXCELSIOR' HIVES, OR EVERY COTTAGER AN AMATEUR HIVE-MAKER.

(Continued from page 105.)

The dummy or division-board is shown in ground-plan at Fig. 13; it must be exactly the width and depth of x;



Fig. 13. Ground plan of Division-board.

if strips of India-rubber, felt-scrap, or leather,  $\nu \nu$ , about 1 in. wide, and the depth of lining be cut and nailed under  $t t$ , it will make it fit quite air-tight; if now a frame-top bar is nailed on the top of division-board, and one on the top of  $x$ , it will be ready for the frames; by nailing another board on  $t t$  it may be made double-walled and packed between.

Now make a slight-board  $k$ , Fig. 14, it ought to be a good size and strong, so cut it from the same stuff the gable ends  $c c$  are cut from, and nail firmly on to case  $x$ , let it slope as shown (the head of which can be made by the planer to throw off the rain.

The porch and sliding-entrance is made by taking a straight piece of wood, 4 in. to 6 in. wide,  $\frac{3}{4}$  in. to 1 in. thick, and 9 in. to 12 in. long, Fig. 3. Plane one edge, so

that it will lie flat on  $k$ ; now draw a line  $A A$  perfectly parallel with the edge  $n n$ , down which saw in a slanting direction, forming  $a a$  and  $m$ , see Figs. 3 and 4; the roughness of the sawing may be just planed off, and should now be put together in the same order as it was before it was cut, and placed on the flight-board  $x$ , with the square blade  $a a$  on the same side of the same thickness under the frame-play, and firmly nail it to the case  $x$ ; take the square away, and a smooth slide freely backwards and forwards; saw it in two at  $b$  (you could by sawing it slant on one side and turning it over, doing the same on the other, make it into a 'Cheshire' V entrance, but I do not like this V entrance at all) and you have a sliding entrance, it making the shade and porch. No rain can drive into the hive, bees have a greater advantage over robbers; and although the bees have a fine step to climb, it is nothing in comparison to the advantages, or the climbing they have to do within.

The live is now ready for the top  $f$ , which should be put on with hinges on the side, and fastened with a cotter and staple on the other; two screw eyes will do very well; the rod,  $f$ , should just come to the middle of the live; it may do the same on the other side or go beyond it.

The advantages of having a roof on hives, and which will form a lid for the heavy ones, to lift off, and put some where on the dirty ground, very often at a loss with respect to what is spoiling on the ground, will soon make itself known; you will just put the two systems together, and all things will be done. High hives, as they are called, are perfect, but when a loose piece of board is put on the top, where it is not meant to be, the more one thinks of it, the more absurd it seems.

The live is now ready for painting; first give a thin coat of white wash, then a coat of red earth, made of red earth and water, and a coat of oil paint. Now let it dry, and put on the final coat of oil paint, but of a different colour, of course no red earth parts should be in it.

If you want to work your live on the building system (a modification of what I call the 'wall' system), others help to do it, or all you need to do is to make another live,  $x$ , see Fig. 10; and nail it to the top of the open end to be put 4 in. wide, make another dummy and use two in frame-top; it will not be fastened to  $x$  in any way. This second live will stand on the top of the lower frames, and if there should be any crevice the bees will make all secure.

There is an improvement I have introduced, so as to enable hives to be quickly taken up, or purpose to remove them to the garden, distend crop of mustard, lines, systems or fruit trees; the necessity of which was brought very forcibly home to me when reading in the *Journal of the Association of New-rying* forty-seven hives a distance of 420 miles, see page 125, Vol. XI, taking for the 17 or two in a week's hard work to pack them in. The ordinary hive provides no facility for doing this with ease and comfort. I have designed a very simple arrangement to accomplish this, but it does not tally of the frames-top projecting beyond the hive-side. Let me here remark that I find frame-tops which project any further on the wide-shed level system very inconvenient in ordinary handling, and the rule of the Association to make it 17 in. long, can only be to have *well enough to do*, on any other reasoning I can't account for it. To make this convenient, which I call a 'Frame-Fastener', I find slating laths the best, they are about 12 in. broad and  $\frac{1}{2}$  in. thick, cut two pieces  $r r$ , Fig. 14, the exact length of the live inside two pieces  $r r$  here  $\frac{1}{2}$  in. longer than top bar, which should be 15 in. long; take mortise them as soon as the corners, and nail them together at right angles, for which use your square to get the true. Now cut two pieces  $v v$ , which must be 1 in. or so less than the inside length of live, and nail them firmly to  $r r$ ; a piece of coarse or wire cloth should be laid over the frames, and this frame-fastener put on the top. The frames

will now all hang firmly in the middle of hive and will not be able to move from side to side. Now fasten L, Fig 4, just on the top and nail it fast, and when M is screwed on, no frame will be able to move any way (when M is removed the frame-fastener can be lifted off); now screw W, Fig 14, just over the dummy, and they will

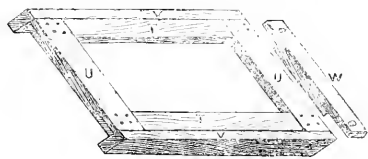

Fig. 14.—Frame-fastener.

be fast on the top for any journey; the front may be fastened up with wire-cloth, tacked on over H J J; if a frame-fastener is made and kept for each hive, and M is simply screwed on (which should always be the case so as to be at hand when wanted); it ought not to take more than one minute to pack up a hive for a long journey; and if they could be so packed railway companies would soon provide accommodation to remove them on to the moors from different parts of the country, and people would soon develop the system, so that all the bees in the country would stand a chance of working on the thousands of acres of heather; but this will never come to pass if hives are likely to fall in pieces or bees escape. JOHN HEWITT, *Sheffield*.

(To be continued.)

## ON THE ANALYSIS OF HONEY.

By OTTO HEHNER.

(Read before the Society of Public Analysts.)

Through the kindness of a number of prominent members of the British Bee-keepers' Association, I have recently been put into possession of a large number of samples of honey of un doubted genuineness. In many instances the origin of the honey was known, that is to say, the kind of blossom from which it was derived, as far as this is possible. Some of the samples were extracted from the comb by the bee-keepers, many of them by myself. I was urged by the Association referred to, to undertake an investigation into the nature of honey, and, if possible, to devise some means for the discovery of its adulteration, on account of the injury done to vendors and producers of the genuine article by the competition of wholesale manufacturers and importers of spurious products.

The information available consists mainly of a paper by Dr. J. Campbell Brown, *Analyst*, vol. iii, p. 167; and of a chapter on Honey in Dr. J. Bell's work on Food, vol. i, p. 115. Most other works on Food also deal with the subject of honey, but do not give precise instructions for the detection of adulteration.

Dr. Campbell Brown comes to the conclusion that genuine honey contains from 1.55 to 19.5 per cent of water expelled at 100°; from 5 to 11 per cent of water expelled at a much higher temperature and loss, very small amounts of insoluble and mineral matters, the rest being almost equal quantities of levulose and dextrose, cane-sugar being in all probability absent. He finds that all the samples he examined are more or less levo-rotatory, a solution of 16.26 grm. in 100 c.c. of water polarising from -3.2 to -5 at 60° Fahr.

Dr. Brown's paper might be held to give sufficiently precise information available for the examination of honey, were it not more or less contradicted by Dr. J. Bell.

In five analyses of honey Dr. Bell finds the proportion of water to vary from 17.10 to 23.32 per cent, glucose from 66.5 to 74.0, and he gives as third principal constituent a sugar not identified, only partly fermentable, without direct action upon cupric tartrate, but gradually converted into glucose, when boiled for several hours with dilute sulphuric acid. The amount of this 'sugar not identified' varies from 4.48 to 10.12 per cent. There are also small quantities of gum, wax, and inorganic matter, their total varying from .8 to 3.6 per cent.

Singularly enough, Dr. Bell is silent about the polarising energy of the samples he examined. He states that 'Glucose cannot be detected by chemical means, and only by the polariscope when in sufficient quantity to change the angle of rotation beyond the limits found in genuine honey;' but as he does not give these limits, nor, indeed, a single polariscope observation, one cannot but consider this statement as a bit of that gratuitous information which confronts the chemist in so many works on Food, and which gives an air of profundity to the author without imparting knowledge to the reader. This is all the more extraordinary in the present instance as Dr. Bell claims to have discovered a 'sugar not identified,' and surely the polariscope would have been an invaluable help in identifying the sugar in question.

It is at once seen on analysing honey, that, on adding the percentage of water (loss by drying at 100°) to that of glucose either before or after treatment with acid, it is impossible to sum up to 100. The difference is variable, from 8 to 19 per cent. Dr. C. Brown considers this to be 'water expelled at higher temperatures,' Dr. Bell an unfermentable sugar, not reducing copper solution. Since saccharine materials, even when anhydrous, lose water on being heated a little beyond 100° (and even below), and since it is quite impossible to fix upon any particular point at which all water is removed and yet decomposition has not commenced, Dr. Brown's statement is fairly open to doubt.

The following analyses are not complete. I have not estimated the amounts of mineral and insoluble matters, as unlikely to afford any important aid in judging of the genuineness of samples, and only in about one half of the analyses has all estimation, which I now believe to be essential, been carried out, namely, the loss on drying at 100°, glucose by Fehling before and after inversion by heating with 10 per cent hydrochloric acid to about 70°; rotatory power of a 10 per cent solution both before and after fermentation, and solid matter after fermentation.

Two to three grammes of the honey take several days to become constant in weight by drying at 100°.

The fermentation was produced in a 10 per cent solution, by the addition of a pinch of yeast, the fluid being kept for about five or six days at about 30°C. Stronger solutions do not ferment well, and become mouldy before all glucose has disappeared. After the evolution of carbonic acid has practically ceased, the solutions were made up to the original bulk, the glucose titrated, and subtracted from the total solids obtained by evaporating 10 c.c., the difference representing mineral, insoluble, and unfermentable matters. In the following analyses, all figures (except polariscope indications) are percentages calculated upon the original honey. The rotatory power represents divisions on the Soleil-Ventzke instrument.

1. From bar-frame hive, taken in 1880, during flowering of beans; clear, Lincolnshire.
2. Straw hive, September, 1881; thyme and clover, crystalline, Lincolnshire.
3. Straw hive, August, 1883; clover and lime, crystalline, Lincolnshire.
4. Bar frame, August, 1881; clover, clear, Lincolnshire.
5. " " August, 1880; clover, partially crystalline, Lincolnshire.



6. Straw hive, August, 1880; beans, quite clear. Lincolnshire.
7. 1882, from heather, crystalline, Dundee.
8. 1882, mustard and turnips, very solid.
9. 1883, bees partially fed on cane-sugar syrup; crystalline, Lincolnshire.
10. 1883, bees partially fed on cane sugar-syrup; crystalline, Lincolnshire.
11. 1882, no syrup feeding, clear; Lincolnshire.
12. Four years old, no feeding; crystalline, Lincolnshire.
13. 1881, Syrian hybrid bees, crystalline, Grantham.
14. 1881, black bees " " " "
15. 1881, from heather, near Perth.
16. 1882, Hertford, crystalline.
17. 1882, heather, Dorset; comb was crystalline before the honey was pressed.
18. June, 1883, fruit blossom and white clover, Kent, clear.
19. May, 1883, black currant; Kent, clear.
20. 1883, cinquefoil, Hertford.
21. 1883, Kent.

	1	2	3	4	5	6	7
Moisture	21.91	17.48	20.94	21.69	20.22	21.04	21.25
Glucose	63.59	69.27	65.74	68.19	68.17	61.42	68.26
Difference	41.68	51.79	44.80	46.50	47.95	40.40	47.01
Glucose after inversion	64.51	79.37	68.25	67.89	67.93	62.96	67.65
Difference	42.60	61.89	47.31	46.20	46.71	41.52	46.40
Difference	0	-1	0	-1	-2	0	-2

	8	9	10	11	12	13	14
Moisture	19.20	21.08	16.31	18.19	16.96	18.15	16.98
Glucose	71.57	67.34	62.18	68.90	68.49	68.17	67.69
Difference	52.37	46.26	45.87	50.71	51.53	49.98	50.71
Glucose after inversion	71.53	69.72	69.94	69.18	68.16	62.91	67.59
Difference	52.33	48.64	47.63	50.00	49.03	46.72	46.88
Difference	0	-2	0	0	+1	0	+1

	15	16	17	18	19	20	21
Moisture	16.19	12.41	20.88	17.79	22.69	17.05	18.57
Glucose	61.37	55.34	64.02	64.74	65.42	70.02	68.15
Difference	45.18	42.93	43.14	47.00	47.73	52.97	49.58
Glucose after inversion	61.16	72.59	64.14	67.02	65.93	70.25	68.29
Difference	45.01	59.18	43.83	49.23	48.74	53.20	49.72
Difference	0	-1	-11	0	0	0	+1
Glucose after fermentation	...	...	1.37	1.39	nil	nil	2.35
Total solids fermented	...	...	5.85	6.21	7.67	4.39	6.29
Difference	...	...	1.18	1.52	7.67	4.39	3.91
Difference	...	...	0	0	0	0	+2

In the above twenty-one analyses the amount of water varies from 12.4 to 25.01 per cent. It is worthy of remark, that the consistency of the honey, whether fluid or crystalline, does not appear to be influenced by the percentage of moisture. Thus, while sample 18, with 17.79 per cent of water, is free from crystals, sample 7, with 23.26 per cent, is almost solid. Some honeys crystallise when a few weeks old, even in the comb (No. 17); others of apparently the same composition, remain fluid for years (No. 1). Bee-keepers, however, generally consider that all honey, if genuine, will in time become solid. No vendor of genuine honey can guarantee his article to remain permanently fluid.

In seven samples out of the twenty-one the percentage of glucose, before treatment with acid, is practically identical with that after inversion. In seven cases the amount has more or less increased, in one case as much as 2.49 per cent; in the seven remaining samples the inversion has resulted in an apparent diminution of glucose, the loss in most cases being small, but in one not less than 5.23 per cent. I do not venture to express any definite opinion as to the cause of this loss, but I believe that the figures indicate the absence of cane-sugar. Even Nos. 9 and 10, produced by bees fed partially upon cane-sugar syrup, show no greater differences before and after inversion than do the rest of the samples. Evidently the cane-sugar is completely inverted by the bee.

The polarising energy of all samples but one was very small, practically nil, the one sample referred to being pressed by myself from a comb, which was partially filled with crystals; the resulting honey contained, therefore, an abnormally large proportion of levulose. After

fermentation, the polarising power of the five samples tested in this direction was also nil, or very slight.

The whole of the samples gave but a very faint turbidity with alcohol, and with barium chloride.

After fermentation, the five samples, 17 to 21, left but from 3.95 to 7.97 per cent of substances other than glucose, whilst their amount before fermentation was from 11.80 to 15.47. Considering that these qualities include the mineral and insoluble constituents, which, according to Dr. Bell, may amount to as much as 30 per cent, and considering further, that even pure sugar leaves after fermentation about 5 per cent of glycerine, benzoic acid, and other unfermentable substances, it appears evident that genuine honey does not contain any unfermentable saccharine matter, as alleged by Dr. Bell. The following analyses simply corroborate this conclusion. They relate to samples purchased both from dealers of the highest repute in the market, and to others suspected to be adulterated even before analysed:

22. Orange blossom honey, San Francisco, 2 lbs. 1s. 3d., very crystalline.
23. Neighbour an I Co., unaromatized pure, crystalline.
24. " " Nurbourne honey.
25. " Fine new honey," 1 lb. per lb., crystallised.
26. Finest Swiss honey, guaranteed always to keep clear, no name.
27. Finest Swiss table honey, A. Alt.
28. Hog's pure honey, partially crystallised.
29. " " English honey, clear.
30. " " Californian honey dew, clear.

	22	23	24	25	26
Moisture	17.91	17.73	15.09	18.86	17.54
Glucose	70.24	65.53	73.46	69.52	68.45
Difference	52.33	47.80	58.37	50.66	50.91
Glucose after inversion	70.87	71.28	73.69	65.81	65.33
Difference	53.96	53.55	58.60	50.66	50.91
Difference	0	0	+1	+1	+3.59
Total solids before fermentation	...	...	1.89	1.43	2.02
Total solids after fermentation	...	...	5.75	6.29	3.45
Difference	...	...	3.86	4.86	1.43
Difference	...	...	+2	+2	+3.99

	27	28	29	30
Moisture	18.68	21.23	18.98	21.25
Glucose	69.60	58.42	68.17	68.17
Difference	50.92	37.19	49.19	46.92
Glucose after inversion	68.77	68.17	68.17	68.17
Difference	49.88	46.96	47.18	46.92
Difference	0	-2.23	0	0
Total solids before fermentation	...	...	1.35	1.35
Total solids after fermentation	...	...	5.39	5.38
Difference	...	...	4.04	4.03
Difference	...	...	17.71	17.78
Difference	...	...	17.71	17.78
Difference	...	...	1.28	1.28
Difference	...	...	4.28	4.28

Samples 22 to 25 possess all characteristics of the pure samples previously commented upon. They are doubtless genuine. I affirm, with an equal degree of certainty, that samples 26 to 30 are adulterated. They all polarise powerfully to the right, both before and after fermentation, they are but very partially fermentable, most of them give heavy dextrinous precipitates with alcohol and with barium chloride much barium sulphate. They are products of the action of sulphuric acid upon starch, consist, in fact, of "corn syrup," or of a mixture of the same, with more or less honey. It is well known that starch sugar, however complete the inversion may be, invariably contains from 15 to 25 per cent of unfermentable, dextro-rotatory substances. Neubauer's process for the examination of sugared wines is founded upon this observation, and has long been used with much success.

All saccharine matters, with the exception of inverted cane-sugar, and which are available for the adulteration of honey, are highly dextro-rotatory. If invert-sugar, perfectly free from the acid employed for its preparation, were used as an adulterant of honey, its detection would appear to be a matter of difficulty, if not impossibility. At the present time, however, the acid, viz., sulphuric, readily betrays the artificial origin of the product.

Inasmuch as the polarising power of genuine honey, agrees with that of invert-sugar, in which the dextrose very slightly predominates, and as there is at present no

saccharine matter known which is fermentable, and without action upon the polarised ray, I incline to the belief, that the 'difference' in the analyses is not due to the presence of saccharine substance. I have made some estimations of the specific gravity of solutions of honey, in the hope that this might afford means to settle the point; but in every case a figure was obtained by reference to tables giving the gravity of sugar solutions which was less than the glucose plus 'difference,' though somewhat greater than corresponded to the glucose alone.

While leaving this, the scientific aspect of the composition of honey, to be yet examined, I would lay down the following rules for the testing of samples:—

Take moisture and glucose before and after inversion as described, the former should not be above 23 per cent, the sugar should not be sensibly greater after inversion than before.

Ferment a 10 per cent solution, take the whole matter after fermentation and subtract from it the percentage of glucose left unfermented. The proportion of unfermentable matter should be no larger than would be yielded by a pure glucose solution after fermentation, namely, about 5 per cent.

Observe polarising power of a 10 per cent solution both before and after fermentation. It should be practically *nil*. *Levo*-rotation indicates that the honey has become crystalline in the comb; *dextro*-rotation which is diminished, but not removed, that there is starch sugar.

Test with alcohol and barium chloride: neither should give any notable amount of precipitate.—*The Analyst for April, 1884.*

## Echoes from the Hives.

*Italy, Riviera.*—Here I am in Liguria itself, and have not yet seen a single Ligurian bee; all are the ordinary black bees. They are kept here in very primitive fashion—rough boxes about four feet high and fourteen inches square. I found a stock the other day in a dynamite box; perhaps, if it had been found in London, it might have made a scare. The stocks are very strong, and they can work the whole year round. The flowers never cease out of the land. Just now the almond and peach blossom, the rosemary, and euphorbia, and a great many other flowers, furnish the bees with an abundant supply.—S. SUTCLIFFE.

*North Wales.*—The rainfall last month was just over 2½ inches, and the number of rainy days was 12. In 1883 the fall was only 1·11 in seven days. No snow has fallen during the month, whereas snow fell on eight days in March, 1883. The first really fine day was the 5th; and Sunday, the 9th, was very fine and warm; indeed, as lovely a spring day as could be wished for. The bees were very busy carrying in pollen. The 15th, 16th, and 17th, were fine days, and the bees were out in numbers each day. On Sunday, the 16th, I was attracted by an unusual commotion amongst the bees, about half-past ten. The sun was shining very brightly, and my garden was full of bees; apparently a swarm. They did not settle, but I very shortly saw a cluster at the mouth of one of the hives, and found the bees were hurrying home again. I saw the queen on the alighting-board, and saw her enter the hive. The same thing happened again about half-past twelve, when my servant saw the bees in the garden, and saw the queen return from a flight with them, and enter the hive. Again in the afternoon the bees came out, and returned; and I saw the queen for the second time. The bees came out once again at about four in the afternoon, but returned as before. On this occasion, however, the queen escaped my notice. She, however, returned to the hive; in

which I have since ascertained that brood is being raised. There was no rain from the 20th until the 31st; but the weather was unfavourable to the bees, being very cold, and the wind for the greater part of the time from the east. When watching the bees taking in pollen I have been much struck with the great variety in colour. Some are nearly white, some nearly black; all shades of yellow from the lightest to a deep orange colour; and here and there a bee with a small quantity of scarlet pollen. I also noticed a few carrying pollen of a deep crimson colour. I am glad that an association has been started for Gloucestershire.—H. B., 2nd April.

*Sault Corvallis.*—A week's east wind at the end of March keeps our bees indoors. It has since been milder, though much overcast; and it is astonishing to see how our busy workers avail themselves of every possible moment for their labours. A gleam of sun draws them out, but they must keep their weather-eyes well open for showers, which sometimes fall heavily. A word on bee-flowers. I fancy our earthen hedges must supply a great deal more natural food, and of a more varied character, than is to be found in many parts of England, so that, after crocuses, we need not trouble much about anything for March but wallflowers, and a good bed of white anemils. It is rather curious that, closely allied as anemils is to the latter, I rarely see a bee on my *A. Gagea*—now so lovely in lines parallel to double white daisies. But *bee-daisies* are the things for me. After laurel come ribes; but there is nothing like *Berberis Darwinii*, on which bees are well-nigh as thick as I hope they will be hereafter on *Limonanthus*.—C. R. S.

*Gloucestershire, Fairford, 7th March.*—The bees are having a fine time of it, and are making the most of it. The anemils and wallflowers are very fine, and the plum-trees have not had so fine a blossom for the last four years. I have four bar-frame and two flat-top skeps, and they are all very strong; as the weather was so mild in December, and the bees so often on the wing, I thought it best to give them some sugar-cake made of 6 lbs. of sugar, but they did not consume a quarter of it. If the present favourable weather continues we may hope for a good season which will help to encourage bee-keepers to join the Association.—J. COOK.

*Hereford, April 2nd.*—On March 16th nearly a week of fine sunny weather with warm south wind set in, and the bees did wonders on the willow-blossoms, crocuses, and even anemils were neglected, and in my strongest hives I found in every comb quite a quantity of new honey. The weather has since been colder, but brood-rearing has been much stimulated. I found in one hive seven frames of brood, six with uniform sheets of sealed brood reaching to the bottom bar. A bee-keeping friend (not a novice) reports finding a queen-cell in quite an advanced stage (this in March). I regard the willow as the most valuable of all spring honey-producing plants; it certainly has done wonders this year. By-the-way, in this county, where it is plentiful, I have never heard of the existence of foul brood. A bee-keeper in this neighbourhood recently sold his stock of twenty-two hives of bees by auction. The bees were in bar-frames—Ligurians, hybrids, and blacks; the highest price was 25s., and the lowest 11s., the average being 18s. 4d.; strangely enough the best black stocks fetched as high prices as the best Ligurians and hybrids.—A. WATKINS.

*Co. Armagh, 4th April.*—Owing to the very mild winter, bees kept active all the season, and are now in most instances in want of food. I have heard of many in this and adjoining counties who lost all their stocks last month by starvation. In some cases the hives were largely stocked and had several patches of brood, but the owners thought they were well enough as they were soon constantly on the wing. Such dearly bought experience will no doubt deter some from taking, and

frighten others into giving up bee-keeping, but a little perseverance will eventually have its reward in well-finished sections. Some have not lost a single stock owing to careful packing for winter, and judicious feeding where required. A farmer assured me the other day that the stings of bees were most dangerous, and gave as an example of their power, a milk-brood of his and mine whose horse was severely stung a few years ago while ploughing, and in a short time afterwards changed from a brown into a pinto!—H. W. LINTY, M.A., *Traveller, Co. Meath Bee-keeping Station.*

## Queries and Replies.

QUERY NO. 750.—*Mr. Hewitt's Beehive.*—Perhaps Mr. Hewitt would be kind enough to reply to the following questions through *B. B. Beekeeping*. (1) In your Excebsford hive, how do you rain-proof the roof after being water-proofed? You say that the roof after being water-proofed with oil and tallow paper, is then painted like the box, in which I understood that the box was painted. I have got some of the above boxes (I believe they are) but I cannot find out, and there are joints through which rain could drive easily. Should the sides be water-proofed with pitch and paper like the roof, and then be painted? (2) What is to prevent rain driving in between the front box, where they meet, as I find rain falling in your wood-cuts that the roof does not fall over the box, nor are there any joints or fillets made on to keep out the rain? (3) How do you protect yourself from the bees getting into your frames, when you allow an open space of an inch in depth for ventilation? (4) Is the roof not very liable to be blown over, or the whole hive capsized, by the wind, when the roof projects over the box, and the large ventilation opening is exposed to the wind, necessitating the use of a wind-breaker, raising it up? (5) Do you rain-proof the sides of the frame (staining paper) to the same? Would it not be highly in my interest to rain-proof with the same as far from the top of the box? I fancy that you would not have elbow-room. Q. Q. Q.

REPLY. (1) Sufficient cloth is applied in the concluding portion of my article to make the sides water-proof. It does not matter whether the sides are painted, if not, more paint will be required. You may use oil paper the sides if you like, if it is not done, the roof will make it water-proof, but to prevent it from getting dry, and make it waterproof, you may use tallow, and paint, see fig. 5, and direct us to your roof. I have found no rain to drive in so far, neither do I expect any. (2) I don't use feeding-bottles, but if others can get by. (3) Very liable, if the wind is strong enough, but not more than other hives. If you are afraid of such a catastrophe, drive four strong stakes in the ground, and make it secure with rope against a cyclone. (4) No, I do not, if you use frames with top bars. If your elms cannot work in tea-boxes, or sawing machine boxes, they will be shallow enough, and long enough, too, for that matter, and the sides will be painted also. JOHN HEWITT.

QUERY NO. 750.—*Dr. L. Malvern.*—1. *Artificial Swarms.* Why, at the right time, may we not make an artificial swarm, by moving a comb with its bees, and cell into a new hive, put it in the old position, and fill up with workers comb? It is all very well to say, Move the queen on a comb; I have never yet found her, and it is not likely that I shall, when swarming time comes. 2. The plan you suggest would not be likely to succeed, at least at first, might elapse before the workers had, and three weeks longer before young bees were produced, thus losing five weeks of the best part of the season, during which time so many of the old bees would have

exhausted themselves that the whole lot would be so weak as to be useless. You must learn to find the queen. She is very difficult to find some times, even by experienced bee-keepers, while at others the first frame lifted exposes her to view. Take an empty hive, place it upon the stand that under examination, and search carefully on both sides each frame as you lift it out, disturbing any small clusters of bees which might conceal her. Put each frame, as you examine it, into the empty hive, and you will most likely find her. If not, reverse the position of the hive, and try again. Do not attempt all this except in swarming weather. 3. What is the meaning of a crackling sound, like boiling fat, in a hive? 4. There is generally a slight sound of movement to be heard in a strong stock, but we never heard any so loud as you describe.

QUERY NO. 751.—*Dr. L. R.*—1. *Feeding.*—About a week ago there was a sunny day here, and my bees began to come out. Seeing that the sun was a bright one, and that many spring flowers were out, I began to line with syrup in all my hives. But the sunshine passed away, and the weather has been very bitter ever since, and the bees do not come out, and remain in clusters pretty much as in the depth of winter. Having begun the slow feeding, however, I kept it on ever since, thinking it better not to discontinue it, having once begun, and every day expecting a change to sunny weather, which might result in which change has never come. Now, on Friday in continuing this stimulating feeding, which is still continued, or will it in a friend has suggested to cease them to save the food, and only insure the brooding. I give them about a third of a pint daily. 2. You are quite right in continuing your feeding, and as the number of bees increase they will soon overtake the small amount of supply, and use what they have on hand. You may also give them more than a pint daily. 3. *Direction of the wind.*—The books say, examine the hives, and only put them out if there is not a wind to blow the bees in, or rain to fall. Do not disturb the bees, when a storm is on, or when it rains. It is all the same, two processes, and I do not know if it is a good one, or a bad one. I have felt that it is a good one, but I differ from it, though the tops of the hives are fitted on the hives, I have never yet had enough to back with clusters containing the comb, and I have left it to chance. 4. There is no occasion for the presence. You are a very true amount of bees, but without disturbing the cluster, which is not the stones, but below them. Consequently, by not disturbing the queen, she may be present, and the cluster, but as the weather becomes warmer, you may do so, to ascertain the state of the food, &c.

QUERY NO. 752.—*Dr. G. C. Campbell.*—1. *Clay.* I am about to till a meadow to bury near my apiary. Would you recommend any putting in with it any particular sort of clay, or any other seed which would be beneficial bee-food next year? 2. You should sow *melilotus*, and *salvia* afterwards, you have got in your hives. The first will come in next year about the middle of May, and early following it, the clover, making a long succession of them. The first sowing should be made a little later than usual, so that the bees may have the benefit. The second crop of clover (only) will come on about August, and, as you probably know, will give two crops of honey and lay it on, and years, if liberally treated. If a chalk soil, *salvia* could hide the place of clover, and will give two crops annually.

## NOTICES TO CORRESPONDENTS & INQUIRERS.

*Oslo, Artificial Fertilisation.* If our correspondent would try his suggested plan of fertilisation, we should be pleased to give space for the result. His proposed plan is: As fertilisation seems only to be effected when

a queen and drone meet at a considerable altitude, the following plan has suggested itself to my mind: Enclose a virgin queen with a few selected drones in a light cage, measuring, say two feet each way, and attach it to the tail of a kite, or to a small captive balloon, and allow them to remain up aloft for a reasonable time, when, perhaps, the much-wished-for event might be consummated.'

**T. SPARTON.**—*Johnson's Saccharum.*—In accordance with your request, we have procured from Johnson's 'Saccharum Company' a sample of the substance so called. (The sample received does not, however, answer to your description.) It is used for brewing purposes. We are informed that this 'saccharum' is derived wholly from the starch of rice, which is converted into a compound of glucose or grape sugar and dextrin, by the action of high temperature in presence of acid. Theoretically, this sugar would seem to answer the purpose of feeding bees as well as cane-sugar, but practically, in every case where it has been tried, the bees have died. There is in every such glucose a small proportion of ash, consisting of sulphate of lime, iron, &c., and it is possible this may account for the bad effect on bees. The total amount of this ash is exceedingly small, say  $\frac{1}{4}$  or  $\frac{1}{2}$  per cent, but in the delicate organism of the bee the slightest trace of insoluble matter appears to have an injurious, if not fatal effect.

**T. B. GARLAND.**—*Queens in Second Year.*—A queen of 1883 is in full profit this year; but by the time the spring of 1885 arrives, she will be past her prime. Therefore, it would be better to supersede her during the coming summer. Young and vigorous queens are the parents of strong stocks. Cottagers who destroy their bees act, without knowing the reason, on sound principles. They always 'put down' the swarms which have the old queens, and reserve the stocks which have young ones; hence the success, or rather the want of failure, of the skep and smotheration system.

**THAMES VALLEY.**—1. *Different Frames in Same Hive.*—Yes, temporarily, you can do so. Your difficulty shows the evil of having two systems in use in one apiary. 2. *Surplus Stores.*—Although now well supplied, a time will probably arrive when rapid breeding is going on, and the income of honey ceases, owing to the weather, when your stored combs will be of service. Then uncap the cells, and place the combs behind the division-board, raising the latter  $\frac{1}{2}$  inch, to give the bees access to the stores. 3. *Sections in Combination Hives.*—Twenty-four 1-lb. sections are quite enough to give at one time; as they are completed you can remove them, and give others to be filled.

**R. J. P.**—*Bees Clearing Honey from Cells.*—Your bees must have consisted of very weak colonies not to have cleaned the frames after extracting. You may safely give them to any hives requiring food, or to swarms, if not used before. You will very soon find the combs cleaned and polished.

**GARDNER.**—1. *Giving Frames of Comb-Honey.*—Give back the frames of comb-honey as the bees require it, uncapping a few of the cells containing honey, and placing them outside the cluster of bees and combs in the hive. 2. *Foul Brood.*—Foul brood is so fully described in all bee books that we cannot give space to re-describe it. It is a perishing of the brood in the pupa or nymph stage, which becomes putrid, and in an advanced state gives off an offensive effluvia, and is highly contagious. 3. *Queen-cells in Hive.*—Possibly, the queen-cells may be of last season; at all events do not destroy any. The bees will best know what to do in this case.

**J. J. CHINICK.**—*Queens and Non-Swarming Skeps.*—It is by no means certain that because your stock did not swarm last year that it possesses an old-queen. On the contrary, it is more likely that the reason of its

not swarming was that it *changed its queen*—that is, it destroyed its old worn-out queen, and raised another to take her place. In most cases of non-swarming skeps this takes place. Therefore, we advise you leave the colony alone, if domiciled in a skep. If in a frame-hive, an inspection will tell you whether the queen is old or young. 2. *Queens-Introduction.*—When introducing a queen, the old queen must first be removed, and the new queen caged in the hive for forty-eight hours. To act as you propose would be certain and instant death to the strange queen.

**WILLIAM PEARS.**—1. *Price of Ligurian Swarm.*—It would be an easier way of ascertaining the price of a good Italian swarm if you were making application to dealers in bees. 2. *Cook's Manual.*—The general instructions in *Cook's Manual* are in harmony with practice of bee-keepers in England, and may be followed. As a book for bee-keepers, it is of the highest value. 3. *Bee-keepers in the North of England.*—There are no Bee-keepers' Associations in either Northumberland or Durham. We have among our correspondents several intelligent bee-keepers in these counties. We should be pleased to note that they had commenced an Association for mutual information and strength.

**LINCOLNSHIRE BILL.**—1. *Drone-trap.*—There is no difficulty in procuring a drone-trap from any purveyor of hive-appliances. 2. *Drones.*—We do not recommend the destruction of drones as soon as the young queen becomes fertilised. The worker-bees evidently value their services during the summer months; and when these services are fulfilled, they get rid of them; at the same time the experienced bee-keeper takes measures to limit the number of drones in his hives. 3. *Puff-ball.*—The use of puff-ball is not injurious to adult bees. The operation should be performed without loss of time. The bees, if in the open air when recovered from the comatose state, would fly back to their old hive. They are not disposed to be quiet when relieved from the effects of puff-ball, but are remarkably lively.

**H. M. G.**—If the Blyth Competition is faithfully carried out, and the advocates of the bar-frame, the skep, and the Stewarton, enter the lists in competition, the information you desire will be obtained.

**H. V. E.**—A letter from the Rev. H. W. Lett, M.A., embodying your ideas, will be found on page 132.

**J. E. L. W., and H. PARKER.**—*Driving Bees, &c.*—The best time for driving bees is about twenty-one days after they have swarmed. The modes of driving and transferring have been so frequently described in the *Journal*, that we must refer you to previous numbers, and to that valuable volume of bee-keepers, *Modern Bee-keeping*, where full directions are given.

**A. COLB.**—We see no difficulty in keeping the number of hives in the shed described.

**R. FORT, Morebunhamstead.**—*Suspended Animation.*—The bees which you described as 'dead,' and which were forwarded to us with a view to ascertain the cause of death, were, with the exception of a few, when they reached us full of life and action. Evidently they had been beguiled by a beam of sunshine to venture out of their warm hives; the cold winds had caught them, and had prevented their return. Had they been picked up, and conveyed to a warm place, they might have been returned to their companions. We presume that the warmth derived from their being closely packed in the box, and the motion caused by their passage to us, had restored their seemingly lost vitality.

\* In consequence of the holidays we have been obliged to go to press two or three days earlier than usual, which will account for some of the Queries not receiving replies, and some communications not being inserted.

# THE BRITISH BEE JOURNAL

Communications to the Editor to be addressed 'STRAN-GEWAYS' PRINTING OFFICE, Tower Street, St. Martin's Lane, w.c.'

[No. 115. VOL. XII.]

MAY 1, 1881.

[PUBLISHED FORTNIGHTLY.]

## Editorial, Notices, &c.

### THE DISTRICT SYSTEM FOR COUNTY ASSOCIATIONS.

From the discussion raised by 'Platelayer,' with regard to a Lower Grade of Experts, another discussion has arisen on the subject of District Advisers, which is no less important for the interests of County Associations. The intention, as we understand it, is to provide the cottager with what may be called a 'standing' adviser, residing in his own neighbourhood, to whom he may always have access when in need of advice and counsel in the management of his bees. It is very significant that the idea has originated in Hertfordshire, which for some years past has had the advantage of a well-managed County Association. We are not sure whether the idea of District Secretary had its origin in Hertfordshire or Lincolnshire, but we think we are right in supposing that Hertfordshire was the first county to give the idea any practical effect. It is only in a well-organized County Association that the idea of *District* Advisers, or *District* Secretaries, can be entertained at all. Where a county is not divided into districts, the very nomenclature seems to be out of place. And this division of a county into districts seems to us to be the chief characteristic of a well-ordered Association. *Divide et impera* should be the precept inculcated upon every County Secretary. Every such Secretary should possess a map of his county, with the different districts into which it is divided painted in various colours. Such a map should also be in the hands of each District Secretary.

We are sure that the Rev. J. L. Seager, or the Rev. F. S. Selater, the Herts and Buckinghamshire Hon. Secretaries, would allow any of their fellow-workers to see and copy the maps of their respective counties which they have prepared for this purpose, and which we hope they will lay on the table at the next Quarterly Conference. A plain sixpenny map is quite good enough for the purpose; and we believe that suitable maps could be procured at a cheaper rate if County Secretaries would obtain them through the medium of Mr. Huckle, the Figure of the British Beekeepers' Association, who seems to know a little about everything. But if a county aspires to hold a front rank in the list of affiliated

Associations, it is not sufficient to divide a county on paper, or merely to *appoint* District Secretaries and District Advisers. The mechanism may be perfect, but it requires to be set in motion; and the best way of giving life to an Association is for those in office to work heartily and earnestly together for the good of others. We use the word 'work' advisedly, for the good management of a County Association necessarily implies a large amount of good, *hard job* hard work. If District Secretaries will not *work*, all the efforts of the County Secretary are paralysed. But if the District Secretaries will put their shoulders to the wheel, the effect will soon be seen in the Annual Report.

We know no better beginning than that they can make than by calling all the members in their districts together at quarterly meetings, which should be held about a week previous to the quarterly meetings of the District Secretaries, who should compose the County Committee. All the members of a County Association are thus brought into sensible contact with the County Secretary. All their wants and wishes are made known to him through the medium of their District Chief, through whom the County Secretary in his turn can keep the members acquainted with all that is being done on their behalf at headquarters. No wrong can thus be left long unredressed; no complaint can fail to make itself heard; in no other way can arrangements so easily be made for the tours of experts, the giving of prizes, and holding of exhibitions at local flower shows, the engagement of the Bee Tent, the inspection of cottagers' apiaries when prizes are given for good management, and for all those many schemes which are now so lavishly suggested for giving life to County Associations.

From our experience of the working of County Associations, we have no hesitation in expressing our firm conviction that the District System applied to County Associations is the best way of instructing the cottagers of the United Kingdom in the art of bee-keeping. It is not the idea or suggestion of any one mind, but the result of much careful thought and many combined deliberations bestowed upon this subject, the product in the first instance of that necessity which is the mother of invention, improved gradually by the experience of several years, but by no means perfected yet, and capable of well-nigh unlimited development. A careful perusal of the volume of collected Reports,

which is now in the hands of all County Secretaries, and which, we feel sure, that they will be glad to make as public as possible, will, we think, tend to convince our readers that the high praise we have bestowed upon the District System has not been given without reason, and is not undeserved.

#### PRIVILEGES OF COUNTY ASSOCIATIONS.

As the privileges and conditions of affiliation are now being discussed at the Quarterly Conference, with a view to their revision and improvement, we venture to suggest a new privilege, which we think might with perfect safety be accorded to the representatives of County Associations, and which would, we think, be of great advantage both to the representatives and the Central Committee. Under the existing *régime* the County Representatives have the privilege of making any suggestions or recommendations which may seem advisable to them, and of discussing any questions submitted to them, but without the right of voting upon them. Why should this privilege be withheld? It would, of course, be highly inexpedient, and most antagonistic to the interests of bee-keeping in general, if any county representative were to move that some important measure—such, we will say, as the decision to hold a show of bee appliances at the International Health Exhibition—should be rescinded, and that any operations which had been undertaken in that direction should be brought to an end; and if upon the question being put to the vote of the conference, the assembled eighty representatives (who by some fortuitous concurrence of atoms happened to be all present) were to carry their point by an overwhelming majority against the little band of fifteen which represent the Committee of the British. The Central Committee, which meet every month (and lately very much more often) for the transaction of business, could not allow the work of three months to be annihilated by the vote of those who meet only four times in the year, and cannot therefore be expected to have an equal knowledge of all the bearings of any important measure. The privilege of voting, if conceded, should, we think, be confined to the voting of the county representatives amongst themselves, and with this restriction it seems to us that the effect could be for nothing but good, from whichever side it may be regarded. As regards the representatives, it would give them an additional interest in the discussion, and elicit a much wider and clearer expression of opinion. As regards the Central Committee, it would enable them to learn what was the real opinion of the majority of the representatives, as well as what was the opinion of the minority. At present the only way of arriving at any conclusion upon this point is by adopting the maxim that 'Silence gives consent.' As long as a representative does not openly express disapproval of any measure proposed, he is regarded as approving it. But this is not a legitimate deduction. A representative may be like the mute parrot—a good thinker, though but a poor speaker. He may be shy and timorous, or de-

barred by some physical infirmity from expressing his opinions in public, though intellectually he may be as capable of forming a sound judgment upon a question as he who makes his opinion heard through his much speaking. No man can be too shy to express his opinion for or against a measure by holding up his hand, and so giving his vote. Of course, in making this suggestion it must be distinctly understood that we do not advise that the vote of the representative should be binding, or in any way affect the judgment of the Central Committee. Its effect would be simply to let them know what all the assembled representatives thought about any question before them; a fact which at present they can only guess at from the eloquence of the few and the silence of the many. Speech may be silver, and silence be gold, but we think that an uplifted hand would be of more value than either silver or gold in determining the sense of the representatives upon a question which admits of any variety of opinion. We should be glad to see the suggestion thus thrown out fully discussed in our columns before the next Quarterly Conference takes place, as well as the suggestion made in our last number as to the representation of County Associations distant from the Metropolis. We hope for a full and exhaustive discussion upon both these points. This is the object with which all suggestions are made in our leading articles.

#### SCOTCH AND IRISH ASSOCIATIONS.

In order to give a practical turn to the strife raging between 'Hampshire Hog' and his antagonists, we would suggest that the discussion should be directed to the point, how to make the Scotch and Irish Associations more serviceable for the diffusion of bee-keeping and a knowledge of the art of bee-keeping than they seem to be at present. We differ from 'Hampshire Hog' in thinking that the Irish or Caledonian Association would be benefited by affiliating themselves with the British. 'Home Rule,' in our opinion, offers great advantages in respect of the teaching of bee-keeping. But, on the other hand, we agree with what seems to be the idea underlying the '*grout*' of 'Hampshire Hog'; viz., that both the Irish and the Caledonian Associations would do well to assume more of the character of parent Associations, encourage the formation of Associations in the counties of Ireland and Scotland, and give them the same advantages of affiliation with the parent or central Association which the counties of England and Wales enjoy at the present moment. If this was once accomplished a federation might be formed between the three parent Associations, with a view to combined action, whenever such should be found necessary and desirable.

#### BLEIGH COMPETITION.

When the present number of the *B. B. J.* comes into the hands of our readers, the time for entries, as originally determined, into this Competition will have expired. We trust that many will have come forward and, at the cost of some little trouble to them-

selves, be ready to give the benefit of their skill and experience to bee-keepers at large. Much real gain seems to have accrued from the first experiment, though its rules were of necessity hastily put together, and without that experience of their practical working by which alone they can be made perfect. These rules have been carefully revised and corrected, and due consideration has been given to suggestions which have appeared in the *Journal* in answer to an appeal from the Committee for criticisms upon them.

We regret, however, that so little of the wisdom of our bee-keeping fraternity was elicited by this appeal; and that at last the Sub-Committee was compelled to complete its work of revision with but a scant addition of external light to assist its labours. We cannot, however, refrain from giving expression to our conviction, that the rules appear now in a vastly improved form; and although many will possibly think that they could improve them, and defects, in all probability, will show themselves in the working, we consider that they supply the basis needful for an excellent competition.

Too late for insertion in our last number were received letters from Mr. J. Hewitt and the Rev. G. Shipton, who have shown a keen interest in the success of the competition. These will be found in pp. 151, 152. We regret, with them, that time did not allow the 'revised code' to be laid before the public before it was finally adopted. The blame, however, must rest with the public, who showed so much hesitation in affording their opinions and the needful subscriptions to set the competition going. The revisers are identical with those who two years ago drafted the first code, and have all the while been closely connected with its practical working. They may, therefore, claim to be clear of any charge of haste or immature consideration in their work.

Whilst criticising the principles and details of the scheme, we must not lose sight of its primary object. It is to bring not only varying systems, but also bee-masters in all parts of the country, into competition, and by the results to show to the *Coltuger* that improved bee-keeping is remunerative. Varying climates, pasturage, and circumstances, do not admit of such competition being a complete test of superiority of one system over the other. It can but approximately succeed in showing the relative merits of different systems.

We quite endorse the suggestion that the competition should be a permanent institution, and that it should be far more liberally endowed. Why not, then, instead of finding fault with the earnest work of the promoters, or alluding to the possible 'stupidity of the judges,' give hearty support to the scheme which has gone forth for the year 1884, and at the same time endeavour to lay the foundations of a far more excellent competition for 1885? We would ask critics to open the ball this time, and to send for publication in the *Journal* a complete draft of suggested rules, which, in its turn, would be open to the criticism of others, and afford excellent material for the guidance of those who may be deputed to frame a revised code in the future.

#### IMPORTANT.—EXTENSION OF TIME.

Entries for the Bigh Competition and for bee-hives, honey, &c., at the Royal Agricultural Show to be held at Shrewsbury, will be received up to Thursday, May 8th, after which they will finally close. Address the Secretary, J. Huckle, Esq., King's Langley, Herts.

#### INTERNATIONAL HEALTH EXHIBITION.

The Committee of the British Bee-keepers' Association to whom have been entrusted the arrangements considered necessary for the exhibition of honey and wax and the various methods which lead to their production have worked with a zeal and earnestness worthy of all commendation. They have won the confidence of the Executive Council of the Exhibition, who have entrusted to them the arrangement and the selection of the articles to be represented, and we may rest assured that a wise discretion will be exercised by them so that whatever may be exhibited will be creditable to the Association. The space accorded is amply sufficient for the purpose; it is 13 feet by 26; it is situated in a most central part which comprises the routes leading to the chief attractions of the Exhibition; there is a large amount of wall-space, and an excellent position for permitting the flight of bees. The Committee have received applications for space from most of the leading manufacturers of bee-appliances. The principal honey producers have also applied for space to exhibit honey and wax. Some excellent samples of the honey of the seasons of 1880, 1881, 1882, and 1883, will be exhibited at the opening; and as the season advances there will be supplemented by others.

It is the intention of the Committee to make the Exhibition so far as lies in their power beneficial to all concerned, by giving every exhibitor the best position in turn. By this procedure each manufacturer's goods will be brought prominently before the visitors; and as the Exhibition will be kept open for several months, and will be seen by many thousands of visitors, the advantage of such an advertisement of their wares must be patent to all. The Committee will still entertain applications for interesting objects, and it is to be hoped that their hands may be so strengthened that the Show may be thoroughly representative of all that concerns the science of bee-keeping.

The Executive Committee of the Exhibition have invited the members of the B. B. K. A. to a conference, for the purpose of ascertaining what practical lessons may be deduced from the exhibition of the articles in their department. This conference will be held on Thursday the 7th of August.

#### MIDDLESEX BEE-KEEPERS' ASSOCIATION.

The Secretary, Mr. Fox Kenworthy, The Park, Eding, will be pleased to receive communications from any bee-keepers in the hamlets and villages of the County who are willing to become district secretaries.

### THE FORMATION OF A BEE-KEEPERS' ASSOCIATION FOR NOTTINGHAMSHIRE.

A meeting will be held in the School Board Room, Exchange Hall, Nottingham, on Wednesday, 30th April, at 2.30, to elect the several officers for this Association. The chair will be taken by his worship the Mayor of Nottingham.

### A NUCLEUS FOR A GLAMORGANSHIRE COUNTY BEE-KEEPERS' ASSOCIATION.

The Rev. Z. Paynter Williamson, of Margam Vicarage, Tarback, South Wales, desires to form a Parochial Bee Association in connexion with the British. Could not this parochial association serve as a nucleus for a Glamorganshire County Bee-keepers' Association? We advise all bee-keepers in Glamorganshire who wish to see a Bee-keepers' Association established in their midst to communicate with Mr. Williamson with that intent. We may say that a noted bee-keeper, Col. Pearson, is about to take up his residence in Radnorshire; and if he were communicated with he would readily afford them effective aid in developing their purpose.

### LINCOLNSHIRE AGRICULTURAL SOCIETY.

#### GRANTHAM EXHIBITION.

We desire to direct the attention of our readers to the schedule of prizes (to be found in our advertising columns) of the Show of Bees, Honey, Hives, &c., to be held at Grantham in connexion with the Lincolnshire Agricultural Society. We trust that the Show may receive every support, not only from the bee-keepers of Lincolnshire, but from the country at large. The date of fixture is favourable for honey exhibition.

### R. W. DAVIES' METAL ENDS.

The sample of metal end forwarded is, we consider, an improvement on some of its predecessors. It is light, strong, and serviceable.

### USEFUL HINTS.

The weather up to Easter was continuously favourable, but then, and ever since, it has been as bad for bees as possible. The bright sunshine has tempted them out with empty honey-sacs, hoping to soon fill them with nectar, but the easterly winds have prevented secretion thereof by the flowers. Thus they have failed to meet with the necessary food, and have succumbed to cold and hunger before being able to reach home, perishing by thousands. The numbers of dying and dead bees lying about within a few yards of the hives have been grievous to see. At the same time another and more serious danger has threatened the stocks of bee-keepers who have not taken care by constant feeding to provide the bees with food which they have been unable to obtain for themselves. The large amount of brood in all stages existing and re-

quiring plenty of food has caused an enormous run upon the stores. In some cases drones, in others immature brood, have been turned out. This latter is a sure sign of absolute starvation, and not an hour must be lost before feeding liberally. On the other hand, in well-cared-for stocks, fed liberally, breeding will have been proceeding rapidly, and large populations, consisting almost entirely of young bees eager for work, are present; so that on a change to warm showery weather supers may be put on and other seasonable work commenced.

**EXAMINING HEAR.**—If, on raising the quilt, it is found that the loss of life has exceeded the increase, so that the outside combs are not covered by bees, it would be as well to remove them and close up the dumais temporarily.

**FEMORAL** must be continued while the weather remains as at present.

**QUEEN-REARING.**—Preparations for this important operation should be commenced as soon as the weather permits. It is of the greatest possible advantage to have queens ready fertilised and laying, ready to give to stocks after swarming, either natural or artificial. Full instructions would be too long for insertion here; they may be found in Mr. Cowan's book. The thorough break-up of the cluster generally necessary to find the queen must not be attempted until the weather is warmer. Be most careful not to chill the brood or the queen. She is more easily injured by exposure to cold than is generally supposed. Queens should be raised in the very best stock you have, so as to perpetuate the good qualities of that queen. She may be united to another stock which does not possess such a good one by lifting out the frame with the queen and bees and placing it without disturbance in the middle of the other stock, first removing the inferior queen. No caging is required by this plan, but smoke and a sprinkle of syrup are necessary.

If none of your stocks contain drones, and you have no neighbours whose stocks contain them, you must of course defer queen-raising until drones are about. By inserting a comb containing drone-cells in the centre of the brood-nest of a strong stock, eggs will be laid which will produce drones in twenty-five days. In these days of foundation it may be difficult to find any drone comb naturally existing, but by taking a 1-lb. section, cutting out the comb, thinning it down to 1 inch ( $\frac{1}{2}$  inch each side of midrib), and splicing it into the middle of a worker-comb, ample space for drone-breeding will be obtained. A 1-lb. section will contain upwards of 500 cells.

**SUPERING.**—When giving supers, remove such combs from the stock hive as do not contain brood. The bees which were clustering on these must go somewhere, and they will be forced into the supers and commence work, of course supposing honey is coming in.

**SWARMING.**—Artificial swarming may be proceeded with towards the end of May, but it is far better to wait until you have queens raised, fertilised, and laying in nuclei, so that the stocks are not without laying queens for a day. If they are swarmed, and allowed to raise queens for them-



selves, nearly three weeks must elapse before an egg is laid. The value of saving all this time by the system of nucleus queen-rearing is obvious.

**REQUEENING.**—When spare queens are on hand is the time to remove all old queens, and replace by young ones.

**LIGURIANISING AND UNITING OTHER FOREIGN QUEENS.**—Owing to the danger of queens imported at this season becoming chilled, it would be better to wait until June. Some years ago queens used to be imported with two pieces of comb in each box, between which the bees could cluster, and with plenty of workers, when they stood a much better chance of arrival in good condition than as now imported, on one small piece of comb and with very few workers.

## ASSOCIATIONS.

### BRITISH BEE-KEEPERS' ASSOCIATION.

The Committee Meeting and Quarterly Conference were held at 105 Jermy Street on Wednesday, April 16th. Present, Rev. H. R. Pool in the chair, Rev. F. S. Selator, Rev. F. G. Jenkins, Capt. Bush, H. Jones, J. M. Hooker, D. Stewart, W. O'Brien, Treasurer, and the Secretary. The minutes of the previous meeting were read, confirmed, and signed. It was resolved that the names of Mr. T. B. Blow, Walswyn, Mr. R. Green, Rainham, and Mr. C. Brown, Ballyly, be announced as experts of the Association on three ovals of the next issue of the Annual Report.

The Rev. F. S. Selator gave notice that at the next meeting of the Committee he would move, "That in order to avoid the inconvenience often experienced by bee-keepers by the existence of no standard size for one and two pound sections, it is desirable that the Committee of the British Bee-keepers' Association shall adopt a standard size in each case, and recommend that these standard sizes be adopted by bee-keepers generally."

The County Associations' Sub-Committee presented the amended list of conditions and privileges of affiliation, in accordance with the resolution passed at the last Committee Meeting. Resolved, that the same be adopted, and presented to the representatives of the County Associations for approval.

The Exhibitors' Sub-Committee reported that they had obtained a commanding site at the International Health Exhibition; they had been granted full control of this department, and had communicated widely with the dealers and manufacturers throughout the United Kingdom in the hope of making a full and useful display of all that will be creditable and profitable to the bee-keeping industry. The Committee have determined as far as possible to include everything that will be of credit or profit to the cause, and to rigidly exclude everything which may bring discredit or injury to the British bee-keeper. They have also determined, in the appropriation of space, to let all the exhibitors have, as far as possible, equal advantages, by changing the position of the articles from time to time, so as to give variety and novelty to the exhibition and to extend the benefits of good position to all in turn.

### QUARTERLY CONFERENCE.

The following representative were present:—Buckinghamshire, Rev. A. Michell; Bedfordshire, Rev. F. L. Roids; Berkshire, Rev. V. S. Mayle; Herefordshire, Rev. A. Roberts and Mr. J. P. Samuels; Kent, Mr. G. Allen and Mr. Jesse Garratt; Hunts, Mr. C. N. White; Sussex, Rev. N. Andrewes; Surrey, Mr. F. H. Lemare; Wilts, Rev. W. E. Burkitt.

The Chairman presented the amended conditions and privileges of affiliation (as adopted by the Central Committee) for the approval of the Conference.

In presenting these amended rules, the Chairman pointed out that, although the representatives could not vote on the question of their adoption, the Central Committee were most anxious to have their views relating to them. It was most desirable that the County Associations should at these Quarterly Conferences make their wants and wishes known as much as possible. If the County Representatives would bring forward subjects for discussion from time to time much good would be done. Concerted action would be sure to produce beneficial results. Conditions 1, 2, 3, and 4 (as follows), were unanimously approved of:

1. Each Affiliated Association shall be established for one County only. No two counties shall be united together for the purpose of forming one Association, nor shall a county be divided for the purpose of forming more than one Association, except with the approval of the Committee of the British Bee-keepers' Association.

2. Each Affiliated County Association shall pay an annual subscription of one guinea, which shall become due on January 1st in each year.

3. Affiliated Associations shall adopt the same designation as the central society (with the exception of the substitution of a county name for 'British'), and add the words, '(In affiliation with the British Bee-keepers' Association)'

4. Each Affiliated Association shall hold an annual general meeting, and elect two of its members (not necessarily residing within the county) as representatives to attend the Quarterly Conferences of the British Bee-keepers' Association; and also issue a yearly report, and an audited balance sheet made up to 31st December in each year; such reports to be issued by the 1st of February.

A long discussion, however, ensued respecting the mode of electing the representatives to attend the quarterly meeting of the British Bee-keepers' Association.

The Rev. W. E. Burkitt considered that provision should be made by the County Associations for the payment of the travelling and other expenses of the representatives. It was of considerable importance to the County Associations for their representatives to be present at these meetings, and each County should provide for the payment of their expenses. The Wilts Association had always provided for his expenses in attending.

Mr. White supported Mr. Burkitt's views, and considered that provision should be made in the rules of each County Association for the payment of the expenses of at least one representative to attend these Conferences. Many Counties would probably be able to secure wealthy men to act as their representatives, and so be saved the expense. At the same time he (Mr. White) considered that the best representative any Association could have was its own Secretary.

The Rev. N. Andrewes supported Mr. White's proposals.

Mr. Garratt considered that as the County Associations benefited considerably by the attendance of their representatives, there ought to be no difficulty in regard to the payment of their expenses.

The Chairman and Mr. Stewart pointed out that the attendance of the representatives was most important to the Central Committee; and the County Associations could through their representatives assist the Central Committee very materially in their deliberations for the extension of the aims and objects for which the several Associations are formed.

Mr. J. P. Samuels suggested that each County Association should be allowed the privilege of nominating a proxy to attend these Conferences at any time when either of the regularly appointed representatives could not be present.

The time allotted for the discussion of this subject

having expired, it was resolved, 'That a copy of the conditions and privileges of affiliation as amended be sent to the Secretary of each County Association to report thereon previous to the date of the next quarterly Conference.'

*The Proposed Testimonial to the Rev. H. R. Peel.*

Mr. Peel having vacated the chair, Mr. J. M. Hooker presided. The Secretary read communications from the secretaries of the Dorsetshire, Essex, Devonshire, Herefordshire, Lincolnshire, Buckinghamshire, Carmarthen-shire, and Bedfordshire Associations, expressing their warm approval of the proposal.

Mr. Garratt inquired of whom the Committee of Management was composed, and whether the present meeting was empowered to deal with the subject.

The Secretary answered in the affirmative, and stated that due notice of the subject had been given to the Secretary of each County Association.

The following proposals were submitted for the disposal of the fund when raised, and in respect to which an appeal should be made for subscriptions.

By Mr. C. N. White, Somerset, Hunts, Hon. Sec. Hunts Bee-keepers' Association:—

'That the fund raised be invested; that the interest be given in prizes annually to the County Associations for the encouragement of modern bee-keeping among the cottager class; and that these prizes be named the "Rev. H. R. Peel Testimonial Prizes."

By the Rev. F. G. Jenkins:—

'1. That the interest of the fund be devoted annually to the encouragement of intelligent bee-keeping amongst artisans and cottagers by prizes given through County Associations.

'2. That, according to the amount of the fund, three or more County Associations be chosen annually by ballot, and that the amount at disposal be divided amongst them, according to population.

'3. That the disposal of the amount thus given to each be left to their own discretion, except that the scheme they adopt must be for the special benefit of artisans and cottagers, and must be submitted to and approved by the Committee of the B. B. K. A.

'4. A County Association can only receive the benefit of the fund once in three years.

'5. The ballot will take place at the same time as the election of the Committee of the B. B. K. A.'

By the Rev. F. S. Selater:

'The amount subscribed shall be invested in such a manner as the Committee may hereafter determine, the interest accruing therefrom to be apportioned annually to two or more county affiliated Associations; having fulfilled the conditions of affiliation, to be applied directly for the benefit and improvement of bee-keeping amongst artisans and cottagers residing within the respective counties.'

'The County Associations entitled to receive benefit from the Peel Testimonial Fund shall be elected annually by ballot, such ballot to take place at the Annual General Meeting of the B. B. K. A. No County Association shall be entitled to receive this benefit more than once in every five years.'

'Each County Association shall make its own arrangements for the disposal of the amount allotted to it, such arrangements to be submitted and approved by the Central Committee at the next quarterly conference held after the ballot has taken place, and previous to the amount being paid.'

Mr. J. Garratt said,—I believe the experience of many is that the giving of prizes does not act as a very great inducement to competition as regards the many; but to the few clever ones it is an undoubted attraction. In support of this I would cite the cases of many of the Cottage-Garden Societies, where one hears the names of certain individuals called out almost incessantly at the distribution of prizes. In my own mind, therefore, as the aim of the Association is to make bee-keeping the pursuit of the many, I am

decidedly opposed to bestowing the fund mainly upon those who are already, by their superior abilities, best able to take care of themselves. My proposal is that experts be provided for visiting all the cottage members of the County Associations. To make this practicable, the country should be divided into groups of counties, such as Kent, Sussex, Surrey, and Hampshire, on the one hand, and Cheshire, Stafford, Derbyshire, and Shropshire, on the other; the expert to make the tour of the group or groups which, by means of the ballot, had been selected for the year. To reap the full value of the system the cottager should be visited three times, in addition to the visit which he might be entitled to receive from the expert of his own County Association. Assuming the latter to take place in the month of April, I would propose that the 'Peel Expert' should make his visits in the months of May, June, and August, thus covering the most important part of the year, and providing practical instruction of a kind and in a manner most suitable to the average cottager's capacity. It is well known that many of a higher class enter upon bee-keeping with enthusiasm, but speedily relinquish it after a liberal expenditure of money, in consequence of the difficulties which accompany their onward movement. How much more, then, is this to be feared on the part of those who are less fortunately placed in life? A great opportunity now appears to present itself for doing an incalculable amount of good, and it is to be most earnestly hoped that the labours so freely bestowed by Mr. Peel on the work of establishing an elevating and refining rural industry may be adequately recognised by all who are interested in its advancement.

Time not permitting for the whole of these proposals to be considered, it was resolved to hold a special meeting for the purpose on Wednesday, May 14th.

The meeting then resolved itself into the Quarterly Conversazione, at which Mr. Cheshire delivered an interesting lecture on 'Honey as Food.' This we are obliged to defer to our next issue.

BUCKS BEE-KEEPERS' ASSOCIATION.

A quarterly meeting of the Committee of Management was held at the 'George Hotel,' Aylesbury, the Rev. H. R. Peel in the chair, on Tuesday, April 15th. Present, the Rev. E. Clay, Mr. Richard Fowler, the Rev. A. Newcombe, the Rev. H. R. Peel, Mr. W. Sturdy, the Rev. S. R. Wilkinson, and the County Secretary, the Rev. F. Selater. The minutes of the last meeting having been read and confirmed, the hon. secretary reported the progress of the Association in the past quarter as satisfactory. The paid subscriptions for the present year already number 231, against 238 received during the entire year 1883; 72 subscriptions remain still to be collected from subscribers in 1883; and these, added to the number already paid, will make up a grand total of 303 members for the present year. There is every likelihood of a further considerable number of new members joining the Association before the end of the year, and the results are therefore expected to prove highly satisfactory. The *district* system is being perfected, original districts having been remodelled, and two new ones formed. The number of districts at present existing is fourteen, and it is most desirable that two new ones should be added in the High Wycombe and Brill neighbourhood.

The quarterly balance-sheet was presented by the County secretary, showing that, at the close of 1883, there existed a balance in hand of *1*l.* 12*s.* 7*d.**, but after allowing for assets and liabilities (the latter including an item of *2*s.* 8*d.** for bee-tent, tickets, &c.) there was a balance against the Association of *1*l.* 11*s.* 8*d.** Mr. Selater handed in the quarterly statement of accounts, and explained that there were assets and cash to the amount of *5*l.**, to meet liabilities of *4*l.* 2*s.* 6*d.**

The Chairman proposed that a separate fund be raised

to pay off the debt on the bee-tent, and he offered to subscribe 5*l.* Mr. Selater seconded the motion, and it was carried. By this resolution the liabilities (40*l.* 2*s.* 6*d.*) are reduced to 25*l.*, and a liability of 21*l.* 2*s.* 6*d.* carried to a special account, to be met by special subscription.

The Secretary then read the report of the experts on their spring tours. Thomas Blow reported:—During two days, April 1st and 2nd, I have visited twenty-three members of the Association, in the vicinity of Stratford, Newport Pagnel, and Bletchley. The bees were in moderate condition—better towards Stony Stratford and Newport than around Fenny Stratford and Bletchley, the latter neighbourhood being a poor one, I should imagine, for bees, the soil being cold and wet. The report added, 'Messrs. Hartub and Long deserve special mention, their apiaries being in a very good state. A curiosity, in the shape of a straw skep, constructed to contain 5 cwt. of honey, is in the possession of Mr. Chappell, of Water Eaton. I need scarcely mention that the bees have never yet filled it, though their owner still has hopes. The Rev. J. Irving has kept bees for forty years, and is certain that his neighbourhood is a poor one. He has an interesting record of the small profits to be made in his district.' S. Baldwin reported that, during the week ending 8th March, he had examined 208 hives, viz. 108 bar-frame hives, 100 skeps and boxes, 6 dead bar frames, 8 skeps. Condition generally fair. Cause of losses—Bar-frame hives, transferring too late; skeps, starved.

It was resolved that in the future more definite reports be obtained from the experts; and that the district secretaries be communicated with as to the best men to act as local advisers.

The Chairman proposed, the Rev. F. Selater seconded, and it was carried, 'That a sum not exceeding 20*l.* be given from the funds of the Association as prizes for run or extracted honey, in one show in each of the districts into which the Association is divided.'

The Rev. F. Selater proposed, Mr. Sturdy seconded, and it was resolved, 'That members of the Association residing on the borders of the county be considered eligible to compete for the medals and certificates offered by the British Bee-keepers' Association at the county show.'

The Rev. F. Selater proposed, the Rev. S. Wilkins seconded, and it was carried, 'That a county show of the Bucks Bee-keepers' Association for the year 1884 be held in connexion with the show of the Royal and Central Bucks Agricultural Association, on Thursday, September 18th, providing arrangements can be made with the Secretary of that Society, and that a sum not exceeding 10*l.* be offered for prizes to be in the hands of the Association.'

It was also resolved that the Secretary be empowered to arrange with the Secretary of the Royal and Central Bucks Agricultural Association for the drawing up of a schedule, including an open class for the best collection of bees and appliances, classes for honey in the comb, extracted, &c. The Secretary was also instructed to make other arrangements to secure the success of the exhibition, the employment of the bee-tent, &c.

The arrangements for the bee-tent were fully discussed, and it was decided no longer to send the tent to shows at the Association's risk, but to require any show authority desiring the tent for a Cottage, Horticultural, or other show, to pay a fixed sum to cover the expenses incurred. Private individuals can be supplied with the tent for garden parties or school treats on similar terms.

The County Secretary was requested to draw the attention of the District Secretaries to the paragraph in the annual report respecting the sale of members' honey. The Association hopes at the county show in September to hold a honey fair to facilitate the sale of honey in

the county; and, if buyers and sellers of honey will meanwhile communicate with the Association's Secretary in each district, he will be in a position to bring buyer and seller into direct communication.

Reports were received from the District Secretaries, from which, in addition to a considerable number of 1883 members whose subscriptions remain still to be collected, it appears that the paid subscriptions for the present year already number 231.

In compliance with a request from the Committee of the British Bee-keepers' Association, the scheme for the proposed 'Peel Testimonial Fund' was considered. This scheme seeks to raise a fund in recognition of the invaluable services which the Rev. H. R. Peel has rendered to the cause of bee-keeping for many years, especially during the tenure of his late office of hon. secretary to the British Bee-keepers' Association. The Bucks Association cordially approve the scheme proposed, by which the fund to be raised will be invested, and the income used to assist Bee-keepers' Associations in affiliation with the British Bee-keepers' Association, to encourage bee-culture amongst the labouring classes. As Mr. Peel is a resident in the county of Buckingham, the above scheme has a special claim upon its inhabitants, Mr. Peel being well known in the county and universally respected.

## Correspondence.

*All Correspondents to be sent long letters for insertion in the Journal, Reports of Associations, Shows, Meetings, &c., &c., are requested to direct those communications to 'The Editor of the British Bee Journal,' c/o Messrs. Strangers & Sons, Tower Street, Upper St. Martin's Lane, W.C.*

### OUR HONEY IMPORTS.

The value of honey imported into the United Kingdom during the month of March, 1884, amounted to 2545*l.* From a private return sent by the Principal, Statistical Office, H. M. Customs, to E. H. Bellair, Wingfield, near Christchurch.

### PEEL TESTIMONIAL SCHEME.

Upon inquiring from Mr. Huckle as to what was decided as to the Peel Testimonial at the Quarterly Conference on April 16th, I was informed that the matter had been adjourned. I cannot imagine how this can be the case, and should like some further explanation as to the reason for the adjournment. The history of the Testimonial after it left the hands of the Lemenhine County Secretary, I believe, as follows:

On the *Journal* for March 1st the esteemed President of the British Bee-keepers' Association expressed her wish that the Committee should, in conjunction with the honorary secretaries and representatives of the several County Associations, take into consideration the best means of complying with the wishes of the members as expressed at the Annual General Meeting, and make such arrangements for the collection and disposal of the fund as they think will best tend to promote the usefulness of the British Bee-keepers' Association.

In the number of March 15th, I find that in accordance with the wish of the President, a resolution was passed, 'That the Committee of the B. B. K. A. should, in conjunction with the County Associations, consider the best means of establishing a Testimonial Fund to the late Hon. Secretary, and make the necessary arrangements for the collection and disposal of the fund.' I read also that at this meeting the question was discussed at great length, and that it was ultimately resolved, 'That the fund raised be devoted as far as possible to the benefiting of artisans and cottagers, and that the

County Secretaries be communicated with to suggest how this can best be carried out.' The arrangements for the collection and disposal of the fund to be decided upon at the next Quarterly Meeting, to be held on April 16th.

In the number for April 15th I read that the President has notified to the Secretary that she will be pleased to give a donation of 50*l.* to the Testimonial Fund. In the same number the secretaries of those County Associations who are unable to be represented at the meeting to be held on April 16th are requested to communicate their views and suggestions for the collection and disposal of the fund to the Secretary of the B. B. K. A., in order that they may receive due consideration.

I can see no reason, then, why the Testimonial scheme should not have been decided at the last Quarterly Conference, and am perfectly amazed to learn that the question has been shelved for another three months, *i.e.*, until the Quarterly Conference to be held in July, which will be the next occasion on which the representatives of County Associations who were specially mentioned in the number of March 1st, and whose concurrence is an essential feature of the Testimonial, will assemble. I feel that this delay is a very poor compliment to the gentleman whom we all wish to honour, and that his classical mind must be painfully conscious of the truth which he must have learnt when a boy in the Eton Latin Grammar.—

\*Gratia ab officio quod mora tarat abest.\*

It seems to me as if we were treating him in the same way as the Wellington Statue at Hyde Park Corner is now being treated. We have put him upon a pedestal very much against his own will, but we have taken him down again now, and we do not know what to do with him.—COUNTY REPRESENTATIVE.

#### THE IRISH BEE-KEEPERS' ASSOCIATION— CERTIFICATED EXPERTS.

At the risk of being attacked by a 'Hampshire Hog' I would venture again to speak a word for Ireland; but as Mr. Lott has put a ring in his snout, perhaps he will not again poke his nose at me, at least while it is tender. It is quite evident that 'Hampshire Hog' does not like those Paddys, and is ready to accuse them one and all of ingratitude; but I can tell him that his assertion was the first I ever heard of Ireland being ungrateful for the kindness of the B. B. K. A. in sending their tent to them. And, furthermore, what I asked would have incurred no expenses, for had Great Britain and Ireland been allowed to compete in the Bligh contest, it would have brought more money to Mr. Huckle as entrance-fee; and in all probability Ireland would not have got any of 'Hampshire Hog's' money, although we have got many a pound through the same animal from England. I am not annoyed at him for flying at me and my nationality as an infuriated hog would do, for if we are all as ungrateful as he is in the habit of reading about, I don't wonder at him shutting the door of his sty against us.

So now for the second clause of my text—Certificated Experts. I would most respectfully suggest a plan that candidates could be examined from the remotest parts of the United Kingdom. If the B. B. K. A. would get printed examination papers such as would be used at any competitive examination, with marks attached, and send on a certificate according to the marks obtained, I would suggest that, to prevent fraud, the examination should be before a magistrate, a clergyman, or the secretary of the County Association the candidate may happen to reside in. Each candidate should pay a fee of at least 1*s.* to cover expenses, and should be sent when he would apply for his examination papers. That each candidate

should send the address of the magistrate, clergyman, or secretary he desires his papers sent to, and that the papers should not be removed from the custody of these gentlemen until they are again sent back to Mr. Huckle. In remote parts of the country where no secretary exists either a magistrate or a clergyman would kindly come to 'Hodge's' house, or even take 'Hodge' to his house, to go through the necessary examination. Then the isolated expert would have his certificate (if he deserved it) in a dark part of the country where he was most needed, and now people would trust him as he possessed the coveted parchment.—PADDY.

#### THE BLIGH COMPETITION.

Variety is pleasing, and diversity of opinion on such matters as the Bligh Competition, doubtless, equally charming; so that the sentiments so ably set forth by the gentleman who delights to subscribe himself 'Hampshire Hog' ought to be welcome. There is, however, such a hoggish flavour and aroma about them, that I trust I may be allowed to suggest that in future he will not saddle them upon all the County Associations. Hampshire, perhaps, will be grateful for his championship.

What appears to have disturbed the bovine mind is a letter in the previous issue signed 'Paddy,' in which it was suggested that the competition be open to the United Kingdom. Would 'Hampshire Hog' specify why he objects to the cottage bee-keeper in the sister island being, perchance, taught something of the art by his more advanced friends, who, by the way, would pay entrance-fee to the funds? Had he subscribed the whole of the 80*l.* he mentions, his argument does not say much for generosity. Or is the thought of a lost prize a prize that might have fallen to 'Hampshire Hog' instead of to 'Paddy'—of sufficient weight to account for this sordid exhibition of enmity? However, the rules are now law, and nothing, I suppose, can alter them. Why the Committee did not follow the suggestion of the Editorial on the subject on March 15th, *viz.*, 'That it is to be hoped that the rules may be on such a broad basis that candidates from all parts of the United Kingdom may be induced to take part in it,' is not my business to inquire; but I am certain such egotistic selfishness would form no part of their objection.

The Rev. H. R. Peel's Testimonial Fund affords further scope to the 'Hampshire Hog' to display traits true to nature. Had Artemus Ward's name been appended, the idea would have appeared a joke, which Mr. Peel would probably enjoy as much as any one. Somewhere I believe Mr. Ward lays down the rule never to subscribe a 'quid' to anything without first bargaining for a quid *pro quo* in return. But 'H. H.'s' communication fails to raise the customary laugh; and the keenness over the ballot mentioned is more suggestive of a family of young 'porkers' doing a stroke of business for themselves than of anything else.

If 'for the same reason' means that Irishmen ought to be excluded from joining in the Testimonial to Mr. Peel, I think it a vile slur on the country.—H. V. EDWARDS, *Mackworth, Derby.*

#### IRISH AND SCOTCH ASSOCIATIONS. FROM 'HAMPSHIRE HOG.'

Please allow me another grant, Mr. Editor, though it seems that I must be careful what I say, as your leading article in last number says something about 'a censorship of the press.' I don't mean any malice; Hampshire Hogs are good-tempered animals; though they mayn't help to pay the rent. No more do some Irish Hogs; they've another way of settling with the landlords, which 'shools' 'em just as well. What I want to

know is, why don't the Irish and Scotch Associations pay the affiliation fee and join themselves to the British Association? I think they would get on much better if they did, and I can't see any reason why they don't, unless it is that they are so fond of Home Rule. You see I wasn't altogether wrong about the cost of the Irish tour; it didn't half pay for itself. I didn't think so much as 40*l.* was taken by the Bee-tent, but Mr. Huckle must know best. By the way, I should have had a word with that gentleman and the British Association if he hadn't put in that bit of an apology to Hampshire. I don't think that the British has ever had a present of five pounds from a County Association before; and they won't get any more if they are not grateful. I hate ingratitude. What can you expect from a Hog but a grunt? H. H.

[We must warn our correspondents that they are treading on the verge of the limits of editorial forbearance, after passing which the censorship of the Press must be exercised. As there seems, however, to be some method and meaning in the grunts of 'Hampshire Hog,' and much justice in the reproaches of his antagonists, we are unwilling to terminate this controversy unless it becomes absolutely necessary. We presume that 'Hampshire Hog' having provoked the attack is *psychodermatous*.]

#### LOCAL ADVISERS.

As the subject of 'Advisers' seems to be one of general interest just now, I will ask you to allow me space for a few remarks as to the *class of persons* best fitted to perform the office?

Every one who has had anything to do with the working of a County Association knows how much prejudice has to be contended with in inducing cottagers to adopt a better style of bee-keeping. There are many people who 'know a lot about bees,' and some who have done well with them too, who have not the confidence of their poorer neighbours; being in some cases supposed to manage their bees by means of 'some charm,' or to feed them with 'something' which is kept a profound secret; and more often whose success is attributed, and perhaps in some degree due, to an outlay which is beyond the cottager's reach. If, therefore, we can find (and I have found several) such men as gardeners, foremen, and artisans, who are both competent and willing to undertake the office, they will in most cases be *believed in*, and be more successful than persons who are more widely separated from the cottagers by means and position.

I earnestly trust that what I have said will not discourage persons of any class from undertaking the office, especially where, as is so often the case, there is no working man at hand to take it. Amongst our most successful advisers there are persons of all classes, but I hear from many of them that they have met with difficulties, and sometimes failure, from the very causes I have pointed out; and I have suggested in more than one case that it might be well to select some intelligent working man, and train him up as a success-or.

I append a form of notice which is being circulated in Hertfordshire, and from which some other associations may be glad to take a hint. J. LONGEN STAVIER, *Hon. Sec. H. B. K. A.*

HITS BEE-KEEPERS' ASSOCIATION. *Notice to Cottagers.* — of \_\_\_\_\_ has kindly promised to give advice and assistance about their bees to cottagers in your parish. If, therefore, you (or any of your friends) require advice or help with your bees, you are invited to call upon or write to \_\_\_\_\_, and \_\_\_\_\_ will gladly visit you or send you instructions how to act, *free of all expense.* —By order, H. B. K. A.

#### A LOWER GRADE OF EXPERTS.

I desire to return my sincere thanks for the very fair way in which you have treated my letters in the *Journal*, and especially to apologise to the gentlemen whom you speak of as having done so much in the interest of bee-keeping, knowing as I do that personally I owe them a debt of gratitude that I cannot repay. Until quite recently I did not think a third-class certificate within the reach of a cottager. That being the case, I no longer advocate a lower grade of experts. That my suggestion, raw though it was, should have set abler minds and pens than mine at work with such results, goes far to prove the usefulness of the Association which I have unwittingly slighted. I feel certain that the results of the change in examinations will promote a better knowledge of bee-keeping universally. — PLATELAYER, *Ra Linge, Ashford.*

We feel great pleasure in inserting this letter, and are sure that our readers will think with us that it does 'Platelayer' as much credit as his fearless advocacy of Certificates for a lower class of Experts has already done. We shall always be glad to hear from 'Platelayer' on any topic. The Herts Association has already taken advantage of the decision arrived at by the Central Committee, of which his suggestions were the primary cause. We imagine that other County Associations will soon make similar requests. Ed.

#### THE BILGH COMPETITION.

I cannot but regret the rules for this competition have been adapted with so much haste; and on looking them over, haste and immature consideration seem stamped upon them. Sub-committees do very well as a rule, but they are not infallible, no matter what consideration they give to a subject. The wisest course would have been to submit their Bill to the criticism of the country before deciding finally on anything; and although I don't expect this will be of any use, still, as it is the first chance we have had, and as I consider the principle of the scheme just what it is wanted to fully develop bee-keeping, I cannot refrain from criticising the rules, because I feel sure if they are acted upon in their present shape, the affair will be another failure. What this scheme should bring out is, the best hive, the best bees, best system of management, and best managers; so that if a new hive, bee, tail, or system, is to be advocated, let its votaries show at least a respectable running in a Bilgh Competition, and if our authorities are to maintain their places as public teachers, let them prove their claim to such, by always showing well in a Bilgh Competition; and if they can't show that they can keep bees profitably, let them cease to teach others. It will be seen if this scheme is properly worked, *everything* in connexion with bee-culture can be thoroughly tested before the public are induced to throw their money away; and let me here remark that I should like to see this scheme adopted as an established institution, to run for two full years, and then one part of the country would be fairly handicapped against another. With 50*l.* or 100*l.*'s worth of prizes, then bee-culture would advance; and each competitor would be able to prove his ability to *keep bees in winter*. As at present arranged, only one winter and two summers are occupied, which is not a fair test.

Rule 1. The object of the Competition should be to show the relative merits of the different hives, bee-masters, and different systems of management as well; and after 'economical' into proper.

Rule 2. I fail to see the wisdom of making any limit as to who shall or who shall not enter; let the Competition be open to all in the British Isles; if not, it is incumbent on the British Bee-keepers' Association to organize Associations in every part before they can fairly

claim to make any distinction; and what have they to do with naming any system to be followed? Three are named here—bar-frame, Stewarton, and straw skep. Now, what is a bar-frame hive? Stewarton hives are mostly fitted with bar-frames, so a Stewarton can be a bar-framed hive, and *vice versa*; skeps can be Stewartons; the late Mr. Pettigrew had a number of straw Stewartons. Before a system can be named in such rules, it must be also clearly defined, to prevent any misunderstanding and dispute; but I fail to see the wisdom of naming any system, or directing that three masters, as it were, should be served. If a man is to have more than one entry, let him please himself what hive, or system of management, he will follow, and if he has a new one of his own, he can then work that; and let him not only name his hives, and system of management, but the bees he will work with, as well.

Rule 3 implies two systems by the word 'either,' though Rule 2 says three.

Rule 5, I notice with satisfaction that some of my previous remarks have been embodied in this rule in a very satisfactory manner; but I regret to see that the time required in making syrup, candy, folding sections, fixing foundations, &c., is not to be entered up as well; also, How are the diaries to be claimed as the property of the B. B. K. A.? This wording did not work well last time, and will not do so again. Why not provide each competitor with duplicate diaries? Then all accounts, &c., will be entered up in a uniform manner, and the diaries can then be claimed at the close, because they are the property of the Association; and if one choose to be stupid, and refuse to give them up, the legal screw could be brought to bear.

Rule 6 is very ambiguous about *worked-out* foundation and *natural* comb, and ought to be made clearer, especially as one in the last competition did not consider 'worked' foundation *natural* comb—neither is it, no matter what may be said to the contrary—according to this rule as it is, *partly-worked* foundation and *natural* comb is excluded, while *fully-worked* foundation would not be. I don't see why queens should be allowed at all; in my opinion, a laying queen in May, June, and July, is worth one-half of a fourth swarm; and if a competitor can introduce them at 3s. each, say in May and June, he would introduce one for every artificial swarm he would make, which would defeat the object of the competition. If queens are to be allowed to be introduced, why not debit them at cost price, or arrange a sliding scale according to what they can be openly bought for; perhaps, queen-cells at 1s. each would be better? I don't see why swarms sold shall be credited at 4s. per lb. the season through; why not make a sliding scale? Suppose, in August, just after the last honey harvest, one has his hives full of bees, and no more honey to be got; 5 or 6 lbs. of the bees will be aged, and will not live a month, at the most. Now, won't it be nice to excite them with a little honey, remove them to a fresh stand, put a dummy hive in its place, and thus 'riddle' all the old honey-consuming bees out, leaving the young ones to hatch the brood, and go into winter quarters, and credit these old *valueless* bees at 4s. per lb., though 1s. for the lot would be more than they were worth? Would such be considered a fraud, or according to the rules?

Rule 10. Whatever the 'plant' consists of at the close of the competition, it should be valued according to fixed rules, viz., bees, so much per lb., and combs of brood and honey at so much; the nature of the rest can be extracted from the diaries.

Rule 12, I consider not fair, as to the decision of three judges being final; if they misunderstand the rules, *some one* will sure to be aggrieved, and is he to be injured, and suffer through the stupidity of the judicial board? I think before such decision is final, a reasonable time ought to be allowed for any one to appeal, setting forth the grounds of his objection to the judgment, &c.,

and then the whole Executive Committee should finally decide. If the competition starts on June 20th, and ends June 20th, 1886, all parties from the north to the south can enter. I consider the rules ought to be spread out more, and not so many items entered under one rule; they look as though figures were scarce. Another point, Why not exclude members of the Committee of the B. B. K. A. from competing? It will not look well (did not last time) for a competitor to be able to elect his own judges, under Rule 12. It is quite contrary to British notions this, and I am surprised it has been overlooked.—JOHN HEWITT, *Sheffield*.

#### BLIGH COMPETITION.

I am much disappointed to find that the rules for the above have been already printed and distributed before any opportunity has been afforded to bee-keepers of discussing and suggesting improvements in them. I am aware that suggestions were invited in your *Journal*, but until we knew what the Committee proposed to do, it was impossible to criticise their proposals, and circumstances vary so much in different localities that it might have been well worth while to have had the opinion of practical men in various places. For instance, as one of your correspondents suggested last month, it might have been better to have reduced the fee for one entry to 2s. 6d. each. This would certainly have induced a larger number to enter, and it is surely better for purposes of competition to have forty entries at 2s. 6d. than twenty at 5s. Then I should like very much to know why competitors are limited to one entry in each class. There are no doubt many like myself who wished to try different situations in the same district. I have, within a mile or so of my house places widely varying in climate and pasturage. And, again, it would surely have been very desirable to have tested, under the *same* management, and in the *same* neighbourhood, hybrids or English bees against Ligurians; and is it not a mistake to credit all run honey at 1s. 1d. per lb., irrespective, as I understand the rule, of quality? Will not this lead to the extraction of a lot of crude, unripe stuff, not worth 6d. per lb., though credited in the competition at 13d.? And why, since a price has been named at which bees may be sold, and it is permitted to purchase and introduce queens, is the introduction of bees prohibited?

By the way, 4s. per lb., is a high price for swarms. I doubt if any considerable quantity can be sold at that price; and if not, it is not fair to credit them so high as a source of profit.

The Committee have no doubt good reasons, for what they have decided upon, but it would have given more confidence in the scheme had those reasons appeared in discussion. As it is, I fear that the number of entries will be very far below what it might and ought to have been.—GEORGE SMYTON, *Chesterfield*.

#### BLIGH COMPETITION.

After the interest that has been taken in the framing of these rules, and the discussion that has been invited in your *Journal*, I must distinctly regret that the rules have been hurriedly printed and distributed, so that all further discussion with chance of amendment has thus been prevented.

Rule 6 prohibits the purchase of bees after the commencement, and yet allows the purchasing of a queen which produces bees; I cannot see the point of this anomaly. I fail to perceive why bees should not be purchased providing Rule 3 as to capital is complied with; it would appear an evident, though doubtless, an unintentional handicap against the competition of the non-swarming Stewarton to rule that with the extra surplus obtained on account of the system such extra

capital obtained should not be employed, whilst the swarming hives are allowed to fully employ their capital. If the swarming system is allowed to purchase hives out of profit, I fail to perceive why the non-swarming system should not be allowed to purchase hives and bees out of profit.

The prices will clearly encourage the sale of bees, and the production of run honey; and there is no attempt at any regulation to ensure that this run honey shall not be raw thin stuff, worth about 6d. per lb.

I would urgently suggest that it be understood that all diaries become the property of the Committee, and that those of unsuccessful competitors, whether they continue to the end or fall out during the period of competition, are to be published as far as space and objects may allow, provided their names except with consent are not appended; failure may touch as much as success.

And it would evidently be advisable that the rates of bees employed should be stated, so that the superiority of the foreign races should be practically established, or disestablished. A WELSH BEE-KEEPER.

MEAD OR METHEGLIN.

On looking at the *British Bee Journal* for 1st August last, p. 126, I notice an inquiry as to the proportion of honey and water for making mead. My late father was for sixty years a dealer in honey, and bought all that the cottagers in his district had to sell. After straining the honey from the comb, he steeped the latter in cold water for about twenty-four hours, to wash the honey from the wax. Of course, in this way he could not tell what proportion of honey and water he was using, but after removing the wax from the water, if an egg would float in it, he considered it strong enough, but if not he added more honey. It was then boiled for about an hour, and put into a brewing-tub for about two days to ferment. It was stirred occasionally to promote the fermentation, but no yeast was used, as it will ferment naturally. He did not put any spices to it, as he preferred the natural flavour of the honey. It was then put into casks, but not bunged up for a few days. He generally had from one and a half to two tons of honey; and as he never sold it all, he had a second brewing of the unsold honey, allowing four pounds of honey to one-gallon of water. I think if the merits of metheglin or mead, as a wholesome and delicious beverage, were as well known as they deserve to be, it would come into general use, and many persons would use it instead of malt liquors. I know that my father's metheglin was always preferred to any other drink by those who had once tasted it; and he could have sold a large quantity of it if he could have produced it. If well made mead or metheglin was fairly brought before the public, it would be largely used, and there would be a *great demand for honey* for making it. At present it is a drink which few persons know anything about. One hears now and then of a bee-keeper who makes it, but it is not known to the public in general. My remarks have applied to metheglin, but I enclose a recipe for making mead, which you can publish for the benefit of your readers if you think it will be useful to them.—E. THOMPSON, *Trigg.*

MEAD WISE.

To every gallon of water, put 1½ lbs. of honey, to which add 1 oz. of ginger, in pieces, and 1 oz. of hops, tied in a bag, to about 5 or 6 gallons. Boil and skim it an hour; let it stand till cold, then put it into the casks, with a pint of brandy to every 6 gallons.

N.B. No yeast must touch it. E. T.

A NEW FEEDER.

If you will kindly allow me, through your columns, to introduce to the bee-keeping world a feeder, which I have used successfully for some years, I feel convinced that you will confer a favour on the fraternity generally. The accompanying engraving will explain its use. The

REGISTERED TRADE MARK "THE RAYNOR"



bottle, which holds about a pint and a half, is fitted with a screw metal cap, coated inside with cork, so that when screwed on tight no leakage can by any possibility take place. The cap has a semi-circular piercing of twelve small punctures, corresponding with a slit in the stand or stage, ¼ inch wide, and an index finger for regulating the supply, rendering the feeder available for gentle stimulation, or copious feeding when all the holes are turned on. The feeding-stage is dome-shaped, and the under-side is lined with cloth, which renders it impervious to moisture, and non-conductive of heat; its diameter is 6½ ins., its depth 4½ ins., and it admits the bees from five frames. The section of stand in the figure represents the interior of the dome, with a projection in the centre upon which the bees cluster, or, rather, to which they extend the cluster from the comb beneath. The stand is entirely of wood, and the bees come into contact with no metal. Its advantages are: that when placed on the frames, over the centre of the cluster of bees, the heat, ascending, renders the interior of the dome the warmest part of the hive, and the bees can feed in the coldest weather, when unable to extend themselves laterally over the combs. From inability to do this many colonies perish while the sides-combs are well stored. The bees can feed at all times without any disturbance of the cluster, excepting extension upwards into a warmer atmosphere.

Experienced apiarists are aware that in a cold, late spring, stimulation, or feeding to prevent starvation, is often necessary before we can examine the hive, or construct the brood-nest in the case of weak colonies, which often perish from having consumed the honey around the cluster, and from being unable to leave the brood cherished in their midst; but with this feeder above

them, supplied with a little warm syrup, they are enabled to nourish the brood and to support themselves.

In past years I have repeatedly saved from starvation, during inclement spring weather, weak colonies, solely by the means of this feeder; and at the present time, with a cold north-easterly wind and sunless skies, three colonies are feeding from it freely and in comfort, whilst from various other feeders, in general use, the bees are unable to take food at all. For its present perfected form I am greatly indebted to Mr. Meadows, engineer, of Syston, near Leicester, who manufactures and supplies wholesale the feeder; and to Messrs. Dines, hive-manufacturers, Maldon, Essex, who will also supply it at moderate rates. The feeder has been registered under the name of 'The Raynor.' In use it is merely required to cut from the quilt a circular piece, corresponding with the inner circle of the domeshaped stage, and to place the feeder over it. Any extra packing of chaff-cushions, &c., can then be applied above as in ordinary cases. Similarly, it can be used on the slop as advantageously as on the frame-hive. I have sometimes left the feeder up in the hive, without any ill effects, during the whole winter; indeed, throughout the present mild winter the bees have fed from it freely at intervals. There has long been a demand for a really good feeder, available at all times in our uncertain climate, and I trust this may supply the want.

I will only add that I have no pecuniary interest in its sale.—GEORGE RAYNOR, *Hitchleigh Rectory, April 18th, 1884.*

#### BLACKS & LIGURIANS AND OTHER FOREIGN BEES.

The time for ordering Ligurian and other queens is now close at hand, and I would crave a space to draw the attention of bee-keepers to the fact that many of our most successful honey-producers are persistently rooting out all Ligurian, Cyprian, Syrian, and Holy Land bees from their apiaries as being worse than useless—positively harmful.

The *Journal of Horticulture* has almost weekly had an article or two hitting these golden bees pretty hard, and this morning (17th April) is another from 'J. P. S.', stating that Syrians 'possess all the faults of Ligurians, with none of their virtues.' This last letter is called forth by one from 'Hallamshire,' stating that he would not have fifty stocks of Ligurian bees as a present, unless he was at liberty to slaughter the queens. 'Hallamshire' then denounces to the Syrians being included in the general and sweeping condemnation, quoting the oft-repeated, but solitary, case of 20% profit being made from one stock of Syrians. Perhaps Mr. H-witt, who must be a neighbour of 'Hallamshire's,' would give his opinion of Ligurians, and inform us if he finds his Syrians good honey-getters, or rather good *surplus* honey-leavers. The subject of the unsuitability of Ligurians to the English climate is, I know, an unpleasant one to bring forward, inasmuch as it means being well 'sat on.' But I believe it to be of too much importance to be shirked, and as no other and able pen brings the discussion under the notice of the *B. B. J.*, I beg to be allowed to do so.

It has occurred to me that one solution to the enigma why Ligurians should be so persistently pressed on the public is the fact that those who advocate them and import them live in the south of England, where the climate may in some degree resemble that of their native land. In Scotland, Wales, and as far south as Derbyshire in England, I have authority for stating they are pernicious to the interests of bee-keeping. Foul brood, I understand, being distinctly traceable to the advent of Ligurians into two apiaries. This latter fact, I should imagine, would rather carry out Mr. Simmins' theory, that foul brood is in some cases caused by

chilled brood, than that Ligurians breed the complaint spontaneously.

As it is a fact that cannot be blinked, that in many districts Ligurians are an admitted failure, I beg to submit that the latitude where Ligurians are a success may be arrived at if those bee-keepers who have found them such will send reports. The writer of the interesting article, 'Four Years in a Bee-house,' in your last issue unfortunately does not give his locality. He scores heavily against the blacks in the matter of honey, but takes off a little of the 'cœur de rose' hanging round the Ligurians by his description of the stinging powers of what he correctly terms these insinuating 'devils.'—H. V. EDWARDS, *Macknooth, Derbyshire.*

#### Echoes from the Hives.

*Belford, Cople.*—Since my last we have experienced some bitter cold weather, the last ten days have been three degrees colder than the corresponding week for the last thirty years; we have had since Good Friday E. and N. E. winds very cold and dry. The most rain was on Easter Monday, 0.15 inches. When examining some stocks on Good Friday, I found drone-brood in an advanced state; but they will be thrown back now, as bees have not been able to get out but once or twice since.—A. F.

*North Leicestershire.*—Bees are rapidly increasing in number, and are in very forward condition for the time of year. The weather for the last eight days has been very favourable, and enabled the bees to visit the blooming black-thorns and plum-trees. Pasturage is both varied and plentiful. Gooseberry, currant, flowering currant, primrose, gilly-flowers, still furnish good supplies, and will shortly be followed by dandelion, apple, and sycamore. Rainfall for March, 1.39 in. Maximum temperature, 63° Fahr. Cold weather and rain kept the bees pretty well within doors from Easter Eve until the following Saturday, when brighter weather set in. The cold winds have been very destructive to bees returning home heavily laden, great numbers falling to the ground and perishing of cold, unless rescued. Of thirty-four bees picked up in front of a hive, after lying apparently dead for three hours, thirty-three recovered, and flew merrily to their hive, after being shut up in a box which was warmed by being placed in a waistcoat pocket. Stocks are still plentiful, and though the nights are frosty the honey flow continues.—E. B.

*Boston.*—*Spring Report.*—I have only lost one weak stock, except two experimental nuclei, this winter, and not a single case of dysentery, which is another proof of the utility of wheat-chaff for winter packing. In consequence of my removal from Stamford I have not stimulated my stocks, but they are breeding fairly. I had only one comb broken in removing over eighty stocks; one pitched over and off a waggon on to the ground, the floor-board fell out, and the frames and bees slid out, only breaking the above-mentioned single comb. ROY. THORPE, *Leagrave, Boston.*

*South Bucks, Datchet, near Windsor.*—During the last few days our bees have commenced work in real earnest; the fruit trees are wonderful masses of bloom, and the fruit bushes furnish fair supplies at present. Some of my stocks have already commenced building comb in their feeders, and if this weather lasts swarming will be early. I wintered ten stocks on home-made barley sugar, and found they preferred it to the purchased article, and it cost little more than fourpence per lb.—P. S. TARRANT.

*West Gloucestershire.*—March 28th to end of the month, cold east winds, with occasional storms; 1st to 13th of April, nice genial weather, which the bees made



the most of; 13th to 25th, bitter cold east winds, with hot sunshine on some days, proving very treacherous to bees returning to the hives, many dropping to the ground were chilled and unable to rise again. To-day, the 26th, the wind changed to S.W., accompanied with nice rain, altering the dry and parched appearance the country has worn during the last fortnight. The 17th, 18th, and 19th, were three colder days than we have had all the winter. — R. W. L.

*South Cornwall, April 21st.* Bees from artificial hives are not unvarying like those from natural objects. The few warm days of the early part of the month have been followed by a fortnight of east wind, and though some days it blew gently, and the sun shone, yet I fear the bees have helped to set my geeseberries without getting much nectar from them. In the middle of the period mentioned, two or three very fine days led me to expect equally favourable ones to succeed; and finding three hives very strong, I ventured to distribute brood. Anxious enough I have since been on days when I dared not rearrange. But this morning being fine and mild, and many bees on the wing, I ventured on just a careful peep, and found those at home quiet and comfortable and prospects encouraging. This afternoon we had a refreshing shower, and I am in great hopes of a mild time, in which the most may be made of red and white currants now opening, to be soon followed by the countless drooping clusters of fifty or sixty black currant bushes, of which Mr. Stumms thinks so favourably. I am glad that Mr. Cowan has given the proportions of salicylic acid and borax. I was about to suggest that a definite statement should be made, with authority, in consequence of a small quantity having been more than once mentioned of late. I am happy to report the successful wintering of nine frame-hives and five skeps, with only one weak, as far as I know. This is a sluggish, inactive lot, though they have brood to work for. I fancy the queen is past her prime. Singularly enough, last year this very hive was queenless; I suppose it must have been a first swarm with an old queen that I had fed. I think some hives have wintered even too well, for I have had to remove sealed stores and compress space during early brood-hatching. Some of my neighbours report strong stocks; one of them is a cottager who takes great pains and is very observant, and I should think could well pass as a third-class expert at least. — C. R. S.

*Essex, Springfield, April 23rd.* A very trying fortnight for bees. The wind has been generally from N. and N. E., weather cold but dry, the thermometer at 40 and 45. Snow fell this morning, and I found ice also. Bees which have been fed are strong and doing well. When a change comes it will probably be rapid, and preparation for supering should be made. — G. H. A.

*Devonshire, April 23rd.* Bees are on the move again, and bee-keepers are looking forward with a more hopeful view for the season of 1884. There has been a considerable thinning of stocks amongst bee-keepers who would not feed their bees last autumn. Mine have wintered well; they were not looked at since last October until April 22nd, as being away for the winter they had to take their chance. The month of March was very mild, and many days were as warm as July; but not so April, for as I write the 23rd inst. there is a keen north-east wind, checking vegetation, and sultry retarding our aparies. Everything now may be considered three weeks behindhand, and a few years ago I had a stock working well in a super on the 21th. I fear there will be but little honey exhibited at our show to be held at Exeter on the 21st of May and two following days, in connection with the Devon Agricultural Society; but we must hope for the best. The total rainfall for March was 3.51 inches; there were sixteen wet days; the most fall on the 3rd, when there were 11.5 cents. In

March, 1883, the total fall was 1.24 inches, and then we had only nine wet days. — W. N. G., *Hon. Sec. D. & E. B. K. A.*

*Leamington, Hon. y Cott, Weston, April 24th.*—After a few nice biday days which the bees enjoyed very much, here we are in what is termed Blackthorn Winter, several days have been very dull and cold, with sharp frosts at night, and a cutting east wind, which very much retards vegetation, and the work of the bees, and of those which dare to venture out, many never return to their hives, being cut down when they have nearly got home. — JOHN WALTON.

*Herts, Somersham, April 24*—The present time is undoubtedly most critical to the lot-alone bee-keepers. What in many instances were magnificent stocks when I wrote my last 'Editor' are now a mass of dead bees for want of a little food. I have warned several people not to let the weight of the live deceive them, but to little purpose. The stocks that have died through starvation may be numbered by the dozen. The throwing out of the bee grubs has with many no particular significance; in fact they say, 'The bees are turning out the refuse of the hive, and if it were not right they would not do it.' I regret the loss of so many stocks, but I hope it will be a severe lesson to the 'penny wise and pound foolish.' During the present month the wind has been almost wholly in the north. We are now having some very severe frosts, which are doing a great deal of damage to the orchards. — C. N. WATSON.

*Leam, Derby.* The weather here during the earlier portion of the month was very fine, and the bees were working hard on the fruit trees then in bloom. For the last few days the weather has become quite cold, and the bees are not out often. My stocks of Ligurians are strongest, though they were the weakest when packed in winter; they now contain nine frames of brood. The blacks seem to have dwindled more than the Ligurians and for the same circumstances. Would it not be well for your correspondents this year to compare the working and brooding capacities of Ligurians *versus* blacks, and thus set at rest this vexed question? — J. P. ALABY.

## Queries and Replies.

QUERY No. 763. (*Co. CLAYTON, Chichester*.) 1. *Discontinued Frames behind Excluder.*—Is it well to set the frames behind excluder at a greater distance apart than 1 1/2 and also to add zinc-tylers (as in sections) to any advantage? *A.* Yes; if you intend to use these outer frames for comb-honey place them 1 1/2 inches asunder. No; if you wish to use them for extracting, the thick combs are more difficult to extract, and more liable to be damaged. Zinc-tylers prevent the queen entering and depositing eggs; but the general opinion is that they unincumber the bees. 2. *Use of Foundation.* Which is most profitable to use foundation or let the bees produce it? *A.* The use of foundation, there can be no question. 3. *Feeding.* When feeding, am I right in putting canvas or chamois-strainer over mouth of bottle? as I have not seen it mentioned in any book. I ask this because my bees never take anything like the quantity of food as stated in *B. B. J.* in autumn. *A.* Yes, but if you require to feed rapidly, the canvas should be very coarse and the mouth of the bottle wide; but there are so many good feeders adapted to rapid feeding, that we are surprised that any one should revert to the ordinary bottle. 4. *Syrup.*—Will bees winter as well on stored syrup as on honey? *A.* Yes, if the sugar syrup given be made from cane-sugar, not from grapes. Most, if not all, the loaf-syrup sold in the shops is manufactured from beet-root, and contains a large proportion of grapes-sugar. The early gathered honey is the safest.

QUERY NO. 761.—(JOHN W. TOWNSEND).—*Temperature of Hives in Summer and Winter.*—Would you be so kind as to inform me what is the correct heat for a bee-hive in summer and also in winter as near as possible?—*A.* Many experiments respecting the normal temperature of a hive of bees have been made by scientists. The temperature of insects, not gregarious, is generally that of the medium they inhabit; but bees have the power of raising and lowering the temperature by varying the activity of their respiratory organs. The result of the experiments made by Mr. John Hunter, the celebrated anatomist and physiologist, was that the heat of a hive varies from 73° to 84° Fahr. About 10 a.m. on the morning of a day in the middle of July, when the thermometer stood at 54 in the open air, he found that on plunging it into a hive it rose, in less than five minutes, to 82°. At five the next morning it stood at 79; at nine it had risen to 83; at one to 84; and at 9 p.m. it had fallen to 78°. On the 30th of December he found, when the temperature of the air was 35°, that in the hive was 73°. In these experiments allowance must be made for the agitation of the bees caused by the introduction of the thermometer into their midst. Huber states the temperature of a prosperous hive in winter to be from 86° to 88°; in summer from 95° to 97°.

QUERY NO. 765.—(H. B.) *Observatory Hives.*—In the Maidstone Prize List, Class I is thus described: 'For the best hive for observation purposes, all combs to be visible on both sides; to be stocked with bees and their queen.' In the Shrewsbury Prize List, Class 172 has this note appended to it, 'Each collection must contain one or more observatory hives, stocked with bees and their queen, all combs being visible on both sides.' Is it not clear that, if an exhibitor in Class 172 sends an Observatory hive, of a pattern such as that which was awarded the silver medal at the Show of the B. B. K. A. in 1882, or indeed any Observatory hive except of the usual uncomb pattern, he will not comply with the terms of the prize list? Very much the same question arises as to the Maidstone List—except that in this case the words 'to be visible' may be said to mean 'able to be made visible'—but it can hardly be contended that the words 'being visible' can be so extended. Will you kindly say what your opinion is as to the meaning of these prize lists; and at the same time you will perhaps say, generally, whether in a class for Observatory hives it is desirable that the bees should be in hives in which the combs are actually visible on both sides, as they are in the ordinary uncomb Observatory hive, or whether Observatory hives in which all the combs are capable of being exhibited on both sides should be admitted?—*A.* The preceding questions are useful as suggesting a guard to ambiguous phraseology. The object in view in offering prizes for the best Observatory hive is to induce makers to devise such an one as shall provide a safe and convenient opportunity of inspecting at all times the operations of the bees, in a complete manner, whilst securing to the bees themselves as full a degree of comfort as may be attainable under conditions not usually regarded as favourable. In this view ingenuity may be directed to the production of hives of a novel character, and therefore not of necessity similar to any to which a prize has already been given.

QUERY NO. 766.—(G. H. DUGARD).—*Queen Introduction.*—I am about introducing a valuable Carniolan queen, and think of proceeding as follows: Take three combs of capped brood from other hives, place these in an empty one (between division boards), the floor of which is made with a sheet of iron, covered with carpet, under which I intend to burn a paraffin lamp, to keep the temperature up to about 60°. The queen, with her attendant bees, would be put into this, kept in and fed until sufficient bees had hatched out to form a cluster, when they would be allowed to fly. The above is a modification of a system given in A. I. Root's *A B C*, as being perfectly

certain, but I am rather afraid of dysentery. Do you think it likely to succeed?—*A.* We have not tried Mr. Root's plan, which you propose to follow, but have no doubt of its success, if carefully carried out. The objections to it appear to be: (a) the difficulty of keeping an even temperature, which for hatching brood, with no adult bees present, should be at least 70°; (b) the loss of time, and weakening of the colony. Young bees do not go to work in the fields until about three weeks old, consequently, neither pollen nor honey would be stored for three weeks after the introduction, and the new colony would be a very weak one. The confinement of the bees for (say) three or four days, at this season, is also an objection, although we do not think it would cause dysentery. If the case were our own, we should adopt the following plan in preference: On a fine warm day, about noon, when the bees are busy at work, divide one of your strongest and most populous colonies, placing a couple of frames of brood with the queen, in a new hive, on the old stand, and adding on both sides frames of empty comb or foundation. The brood, together with the bees returning from the fields, will make a strong swarm. The remaining portion of the deprived hive, consisting, say of eight frames, three at least of which should contain abundance of brood hatching out, must now be removed to a new stand. To this now queenless portion, the same evening give the Carniolan queen, by caging her in a pipe-cover cage, between sealed brood and sealed honey, enclosing beneath the cage a cell or two of the latter. After the lapse of twenty-four hours release the queen, and she will be thankfully received by the young bees surrounding the cage. Nearly all the old bees will have returned to the swarm, and the few remaining will be of advantage to the newly-formed colony. We have never known this plan to fail, a strong colony invariably resulting, which has afforded several subsequent divisions during the same season, thus propagating more speedily the newly-introduced races. It is well to confine the new colony to about four or five frames, according to the quantity of brood, by division-boards, giving more room as the brood hatches out, and the newly-introduced queen requires more room for the depositions of eggs.

QUERY NO. 767.—(W. GRESLEY). *Boiling Sugar.*—Will any one kindly tell me the secret of boiling sugar without it crystallising after it is cold? I sometimes can do it, but not always.—*A.* Your difficulty arises from variation in the sugar employed. Syrup for use in spring may be simply a solution of sugar not boiled at all, and will not crystallise; but the concentrated syrup for autumn feeding, approaching to a saturated solution, is more difficult to prevent crystallising, the addition of some vegetable acid, as acetic, citric, or tartaric, or of cream of tartar (bitartrate of potash), will prevent crystallisation, and so will the addition of a proportion of glucose, but doubts have been expressed whether glucose is wholesome food for bees.

QUERY NO. 768.—(J. W. N.).—*Position of Drone-comb.*—In arranging combs in spring, what should be the position of frames containing drone-comb?—*A.* It depends entirely whether you wish the colony in question to breed drones or not. If the former, when the colony has become populous place a drone-comb in the centre of the brood-nest. If you merely wish the drone-combs to be filled with honey, place them on the outside of the centre frames when honey is coming in freely. Even then, if the queen is prolific, and the hive only moderate in size, drone eggs will be deposited in them. We should prefer to give sheets of worker-foundation in the latter case. 2. *Seizing the Queen.*—In direction to 'seize the queen by the wings,' is it meant that she should be seized simply by the wings, or by the body where the wings join it, as it seems to me that there would be difficulty in getting hold of the wings?—*A.* The direction must be taken literally. There is no difficulty in seizing the wings

of the queen after a little practice. Many apiarists take her gently by the thorax, across the roots of the wings; but in doing so very gentle pressure must be used, merely sufficient to retain the hold, and the abdomen must not be touched. A queen should never be handled except in case of necessity.

## NOTICES TO CORRESPONDENTS & INQUIRERS.

SUMMERSSET.—*Driving and Transferring*.—Your treatment of your stock in a skep is correct, and so is your first proposal to drive a swarm, and twenty-one days afterwards drive and transfer the contents of the skep. You will find your shed very awkward for manipulating bar-frame hives; and we should advise you to stand them in the open. With this end in view, when you drive the swarm place the hive containing it on the stand of the skep, and remove the latter to where you intend to stand one of the bar-frame hives. The same night remove the swarm to where it is to stand. Do not drive until the skep is crowded with bees to the edges of the combs. Care driving directly the queen goes up, or you will have too few bees in the skep. If you should find this to be the case, equalise them by exchanging positions of the stocks on a fine day when many bees are about.

H. C.—*Flour-scake, Water, Syrup*.—Bees do not store flour-scake, nor can they make use of it without water in some form. It is to obtain this necessary that they visit the pond. Bees take more syrup in warm days than in cold because they are more active on warm days.

W. E. M.—*Evacuation of Bees*. The appearance you noticed was only the natural relief after long confinement while brooding was going on, necessitating the consumption of much pollen. The discharge would be found under the microscope to consist largely of the husks of pollen.

C. W. F.—1. *Early Drones*. The drone which you send is perfect, and has apparently been tempted out by the sunshine, and found the easterly winds too much for his constitution. No doubt he has left numerous wisps behind inside; but if many are turned out suspect impending starvation and feed liberally, or much harm will be done to the stock. It is rather early for drones to be hatching; but the season has been unusually early this year, and your experience is not exceptional. 2. *Weak Stock*. We should not advise weakening a good stock to patch up a weak one, rather unite it to another. 3. *Prospects of Stock*. A stock containing only six frames would not be strong enough to fill sections; but by spreading the brood now, at the same time unsealing the stores in the outside combs, it will most likely be strong enough by the end of May to go to work. 4. *Fanning*. The loud fanning you mention is a good sign, and the hives which fan are no doubt crowded with bees. You might examine them, and if you find the outside combs covered insert one or two empty ones in the middle, not both together but alternately with the present ones. 5. *Water in Hive*.—The water you noticed was from condensation, the bees not being numerous enough to warm the hive into the corners. It would have been good policy to have removed one or two outside combs, and closed up the dummies.

INQUIRER.—*Distinguishing the Age of Queens*. There is no certain rule by which the age of the queen can be arrived at by inspection. As a rule old queens are less active in their motions, and less shy than young ones. Sometimes their wings become shattered, and they are larger and less bright in appearance than the young. The age of the queen should be marked on the hive, or a memorandum made of it. Her falling powers may be easily noted, by the small quantity of brood, and the tendency to produce drones, also by the listlessness of the bees.

ANON.—1. *Double-walled Hives*.—You obviously cannot make any hive double-walled without adding to its external dimensions. Double walls are an improvement, as they tend to preserve the internal heat in winter, and prevent over-heating in hot weather. 2. *Metal Rooves*.—You must nail pieces of wood about two inches thick along each edge and each corner of the hive, and nail boards on to them. 3. *Metal Ends*.—Metal ends to the frames are greatly preferable to metal runners to the hive-sides. 4. *Bingham Smoker*.—The Bingham smoker is a good one, although we cannot commend all others by pronouncing it 'the best.' 5. *R-queening*.—Refer to our 'Useful Hints' this issue, and also consult Cowan's book. 6. *Best Hives*.—Opinions vary, the Combination system is generally preferred.

H. B.—*High Competition; Stewart's Hive*.—As the rules governing the High Competition oblige the competitor in the first place not to exceed an outlay of two pounds, it will require a considerable amount of ingenuity to enable him to keep within his means if he elect to adopt the Stewart system. But the rules being now *in full compliance*, the competitor must 'cut his coat according to his cloth.' The dealer's profit might be cut off if the hives were home-made; and with the use of three boxes some honey might be taken the first season, the sale of which would provide capital for increasing the number of boxes.

REV. A. H. HALL.—*Poppies*. Poppies are not injurious to bees. We have grown them purposely for our bees for many years. It has been asserted that their odour stupefies the bees, but we never found such to be the case.

N. WELLS.—*Stocking an Observatory Hive for Shows*.—Only on the supposition that the intending exhibitor was distressed for time would we recommend him to place the bees in the Observatory hive before leaving home. It is far better that the bees should be taken to the show-yard in a travelling hive, with the frames properly fixed, and ample ventilation ensured. They would thus reach their destination in good condition, and the evening preceding the show they might be removed into the Observatory hive, without the loss of many bees. If left to the morning of the show, there would be a considerable amount of bees lost, as they, then considering that their day's work had commenced, would be inclined to fly abroad in search of food.

LINCOLNSHIRE BILL.—1. *R-queening*. We think you must be mistaken as to the age of your queens; but presuming you are right in your assertion that they have reached the mature age of 'at least four years,' it will be wise to requeen your stocks. It would save much valuable time by procuring young fertilised queens, and introducing them to the stocks whence the queens have been destroyed. 2. *Straightening Combs*. Lift the whole of the combs bodily out of the hive, brush the bees off, and straighten the combs, and replace them in the hive. 3. *Syrup*. The syrup that you are giving to the bees is not too thin for the present time. 4. *Swarming*. It is quite possible that the cast you have been at such pains in feeding may be ready for swarming in due time, but actual demonstration will determine this.

J. WARD.—Please refer to previous numbers as to simplest method of packing swarms and bar-frame hives, and to *Mobber's Keeping*.

W. PETERS.—There is no difficulty in cutting out queen-cells from bar-frame hives; it is a more delicate matter from skeps. First ascertain the position of queen-cell, then cut away the comb till you come to it. The bees will soon replace the comb. The best time to transfer from skeps to bar-frames is twenty-one days after swarming. The operation will in some degree affect the yield of honey; but if the conditions are carefully attended to, not to any great extent.

# LINCOLNSHIRE AGRICULTURAL SOCIETY.

PRIZES offered for SHOW of BEES, HONEY, HIVES, &c., to be held at GRANTHAM on THURSDAY and FRIDAY, 24th and 25th JULY, 1884.

- CLASS.
1. For the best Specimen of Ligurian, Carniolan, Cyprian, or Syrian Honey Bees, to be exhibited with the Queen in an Observatory Hive. . . . . 20/0 15/0 10/0
  2. For the best Specimens of English Bees to be exhibited with the Queen in an Observatory Hive. . . . . 20/0 15/0 10/0
- N.B.—It is not necessary that whole Stocks of Bees should be sent to compete in Classes 1 and 2.
3. For the largest and best Exhibition of Super Honey, the produce of one Apiary during the year 1884. . . . . 20/0 15/0 10/0
  4. For the largest and best Exhibition of Extracted or Run Honey in Glass Jars, each Jar to contain one or two pounds net weight of Honey respectively, the produce of one Apiary during the year 1884. . . . . 20/0 12/6 7/6
  5. For the best Twelve 1-lb. sections of Comb Honey, in Crate . . . . . 7/6 5/0 2/6
  6. For the best Twelve 2-lb. sections of Comb Honey, in Crate . . . . . 10/0 7/6 2/6
  7. For the best Twelve 1-lb. Glass Jars of Extracted or Run Honey . . . . . 7/6 5/0 2/6
  8. For the best Twelve 2-lb. Glass Jars of Extracted or Run Honey . . . . . 10/0 7/6 2/6
  9. For the best Glass Super of Comb Honey. . . . . 10/0 7/6 2/6
- N.B.—Competitors in Classes 5 to 9 inclusive must be resident in the County of Lincoln.
10. For the best complete, and most practical Hive on the movable comb principle, five of the frames to be fitted with comb foundation, with arrangements both for

- CLASS.
- storing surplus Honey for wintering. Price not to exceed 30s. . . . . 20/0 15/0 10/0
11. For the best complete, and most practical Hive on the movable comb principle, with arrangements for storing surplus Honey. Price not to exceed 7s. 6d. . . . . 10/0 7/6 5/0
  12. For the cheapest, neatest, and best Super for Harvesting Honey in the Comb in a saleable form . . . . . 5/0 2/6
  13. For the best Honey Extractor . . . . . 15/0 10/0 7/6
  11. For the best and most complete collection of Hives and Bee Furniture most applicable to modern Bee-keeping, — no two articles to be alike. . . . . 60/0 10/0 20/0
  15. For the best Straw Hive, with floor-board and cover, showing the most simple and ready means of managing (with a view to obtain Super Honey) and the best method of Feeding; the Hive to be stocked with Bees working, and the principle to be fully demonstrated. . . . . 20/0 10/0 5/0

**OBSERVE.—Last Day of Entry for Bee Exhibition, July 7.**

MANIPULATIONS WITH LIVE BEES.—Practical illustrations of Manipulating with Live Bees, showing the best methods of Driving, Capturing the Queen, transferring Combs from Straw Skeps to Bar-frame Hives, Uniting Stocks, &c., will be given during the Exhibition by able Bee-masters. Arrangements will be made by which Visitors may view with safety the mysteries of the Hives, and witness the perfect command the Scientific Apiarian has over his Bees. Demonstrations in *advanced Straw Hive management* will also be made with a view to show how needless is the cruel practice of killing Bees to obtain Honey even under the *Straw Hive system of Bee-keeping*.

For Conditions and Forms of Entry apply to Mr. R. R. GODFREY, Hon. Sec. of the Lincolnshire Bee-keepers' Association, Grantham: or to STEPHEN UPTON, Sec., St. Benedict's Square, Lincoln.

## A. G. DAWSON,

Manufacturer of

### BAR FRAME HIVES AND BEE-KEEPERS' APPLIANCES

OF ALL DESCRIPTIONS.

Comb-Foundation, Smokers, Frames of all kinds, Sections, Feeders, Extractors, Honey Jars, Books on Bee-keeping, &c.

ILLUSTRATED CATALOGUE POST FREE.

A. G. DAWSON, Alma Buildings, Macclesfield.

1767

DO not order your Hives and Appliances until you have seen E. C. WALTON'S CATALOGUE for 1884, consisting of 36 pages, fully illustrated.

Send five for W. Stamp on receipt of Address.

**E. C. WALTON,**

NORTH MUSKHAM, NEWARK.

CATALOGUES FREE.

Simmins' Hives, Crates, & Sections.

'FORTRESS HIVES.'

Association 'Standard' Bar-frames, 1s. doz.

J. H. HOWARD, Holme Apiary, PETERBORO'.

1887

### HEAD QUARTERS

FOR

Comb Foundation, Sections, &c.

For PRICE LIST apply to

WILLIAM RAITT, Blairgowrie, N.B.

JOHN T. KINNEAR,

IMPORTER OF

AMERICAN APIARIAN APPLIANCES,

8 REFORM STREET, DUNDEE.

Price List on application.

(65)

# THE BRITISH BEE JOURNAL

Communications to the Editor to be addressed 'SUNBWAYS' PRINTING OFFICE, Tower Street, St. Martin's Lane, W.C.

[No. 146. VOL. XII.]

MAY 15, 1881.

[PUBLISHED FORTNIGHTLY.]

## Editorial, Notices, &c.

### COUNTY BEE-KEEPERS' ASSOCIATIONS.

Mr. John Hewitt, of Sheffield, writing in our issue of May 1st, upon the Blich Competition, advocates the opening of the competition to all the British Isles, and says that in default of this, 'It is incumbent on the British Bee-keepers' Association to organize Associations in every part before they can fairly claim to make any distinction.' We do not agree with Mr. Hewitt as to the throwing open the Blich Competition to bee-keepers indiscriminately, whether they are members of the B. B. K. A. or not. In our opinion the Blich Competition should be one of the *privileges* attached to affiliated County Associations, which fulfil the conditions of affiliation. The central body has hard work to keep some of the Associations up to the mark, and others from kicking over the traces. Some are sluggish and torpid, and produce very little impression upon their county; others are impatient of the very gentle yoke which the Parent Association imposes upon them, refuse to hold their annual meetings at the required time of year, decline to send up their reports and balance sheets, and entertain wild ideas of setting themselves up in antagonism to their parent, and drawing other counties after them into a Cave of Adullam, which shall be a resort for all such Associations as are discontented, and very probably also for all such as are in debt. The only way in which the Parent Association can hope to hold its children together is by offering privileges of affiliation, such as will make it worth the while of County Associations to comply with the conditions of affiliation in order to obtain them.

Having said this much in opposition to Mr. Hewitt's views, we are glad to be able to concur in the after part of his statement, viz., that in order to make a distinction in holding out its privileges, it is incumbent upon the British Bee-keepers' Association to organize Associations in every part—in every part, that is, which comes within its jurisdiction. From the outset the British has been most careful not to intrude upon the ground which should be occupied by the Caledonian and by the Irish Association. We have already expressed our regret that these Associations do not assume more

of a parental character, and institute Blich Competitions and similar privileges for the County Associations which are willing to unite themselves to them. The Caledonian and Irish Associations have both taken up independent positions by not affiliating themselves originally with the British, and their independence must involve the responsibility of acting in a parental manner to those who come under their influence, and naturally look up to them for support and encouragement.

With this limitation, viz., that it should keep within its own province, we are quite in accord with Mr. Hewitt in his view of the duty incumbent upon the British Bee-keepers' Association. But we think that Mr. Hewitt is scarcely aware of the extent to which the B. B. K. A. is fulfilling this duty. Does he know that, with the exception of Rutlandshire and Westmorland, there is not a single county in England which is without the prospect of having an Association affiliated with the central body before the close of the present year? Is he aware that in South Wales the two excellently named Associations in Carmarthenshire and Brecknockshire will soon be enveloped by Association in Glamorganshire, Pembrokeshire, and Radnorshire; whilst the visit of the British Bee-keepers' Association to Shrewsbury at the time of the Show of the Royal Agricultural Society will doubtless produce a similar stirring of the 'dry bones' which are waiting to be clothed with life in the counties of North Wales?

### HONEY MARKET.

We understand from the Rev. W. H. Moyle, the active Hon. Secretary of the Berkshire Association, that Messrs. Huntley and Palmer, the well-known biscuit manufacturers of Reading, are prepared to enter upon the manufacture of honey biscuits, if they can receive a guarantee from some responsible source that they shall be supplied with two tons of pure British honey per week, or 100 tons gathered at the close of the season. The blind stupidity of the last General Meeting in crushing the honey market scheme is now more apparent than ever. There is no responsible body in existence which can give any such guarantee as would satisfy Messrs. Huntley and Palmer. The bearing of their announcement upon bee-keeping generally is so important that we would strongly advise the calling of a special General Meeting to

reconsider this subject, and (as we hope) to reverse the ill-advised resolution passed in February last. Through the medium of the County Associations the British Bee-keepers' Association could no doubt supply Messrs. Huntley and Palmer's requirements, and they would no doubt place confidence in its committee as a *responsible* body.

We understand that they do not wish to be troubled by any private offers of smaller quantities of honey, and that no dealers in honey need apply to them. If they undertake this new branch of manufacture it will be from a wish to encourage British bee-keepers to open a market for British honey, rather than from any prospect of advantage to themselves.

#### BLIGH COMPETITION, 1884-5.

This interesting competition commences on the 20th inst. We are pleased to report that the entries made are double in number compared with the previous contest. The following counties are represented, viz., Herts, Cornwall, Kent, Cambridgeshire, Sussex, Berks, Worcestershire, Wilts, Notts, Derbyshire, Bucks, Essex, Surrey, Herefordshire, Oxfordshire, Lincolnshire, Middlesex, and Gloucestershire. The entries made are principally on the frame-hive system. There are, however, several on the skep system, and the Stewarton is also represented. Each competitor should note that full details of the mode in which he commences the competition should be entered in his diary.

#### ROYAL COUNTIES AGRICULTURAL SHOW: GUILDFORD.

We beg to remind our readers that entries for bees, hives, honey, &c., in connexion with the Annual Show of the Royal Counties Agricultural Society, to be held at Guildford, close on the 11th June. See advertisement in this issue.

#### COMB HONEY IN SECTIONS.

By T. W. COWAN.

(Translated from the 'Bulletin d'Apiculture de la Suisse Romande'.)

Nowhere, perhaps, is the production of extracted honey better understood than in Switzerland, and the extracted honey shown last year at the Zurich Exhibition was all that could be wished for; but in a country where such a quantity of artificial honey is manufactured and where this is served at most of the hotels, even genuine honey is sometimes looked upon with suspicion, especially by those who do not understand its characteristics. The manufactured article, the principal ingredient of which is glucose, is so clear and of such an attractive appearance that many persons in eating it imagine they are eating real honey; and I have frequently heard persons not knowing anything about honey say that, 'that which was opaque from granulation must be adulterated.'

It will take some time to educate people to discern the pure from the false, and in the meantime bee-keepers could very well turn their attention to the production of an article which would not give rise to any suspicion of adulteration.

No one has yet succeeded to imitate honey in the comb, and those who purchase it in this form would know that they are not purchasing glucose.

In inviting the bee-keeper to produce honey in the comb, I know that he will not be able to obtain so large a harvest as by the system of extraction, but he will realise a higher price for it. In England, small boxes or sections containing about 1 lb. each, sell at 1s. 6d. each wholesale, and at about 2s. 6d. retail.

Extracted honey is worth from tenpence to one shilling a pound, according to quality, that being of the lightest colour realising the higher price. I was very much struck, at the Zurich Exhibition, by the absence of these pretty little sections of honey, so common at all our exhibitions, and could not help thinking that if they were produced here there would be no difficulty in finding a ready sale for them. There is a great difference in the appearance of these sections, even at our exhibitions, showing the different amount of care given to their production. Much more care is needed for producing comb-honey than extracted honey; consequently if the bee-keeper is not prepared to give this extra care, he had better not attempt it, as honey in sections not neatly finished is certainly not very attractive. It must please the eye or it will not find a ready customer. But, for those who are disposed to make a trial, I will give the best method of producing these sections, and I am sure that if the instructions are carried out carefully and entirely, the bee-keeper will not be disappointed.

The large hives such as the Layens, are not at all

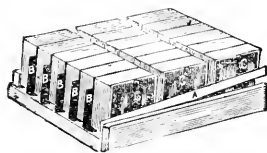

Fig. 26.

suitable, as they are too deep. It is well known that bees more readily store their honey above the brood; therefore, the frames should be shallow and reserved for brood only, whereas the sections are placed on the top and act as supers.

The Dadant Hive, which has a shallower frame, would be more suitable because the bees when they

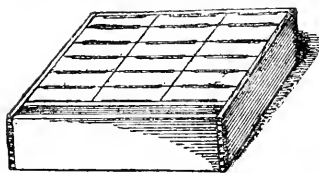

Fig. 27.

found themselves too crowded in the body of the hive, would be forced up into the sections. This form of hive being extensively used in the 'Suisse Romande' an experiment can be made without having to introduce a new form of hive. The supers at present used with this hive can be discarded and their place occupied by racks of sections. There are two forms of racks in use with us, the one with open sides as in fig. 26, and the other having closed sides as shown in fig. 27.\* These racks are made to hold twenty-one sections of 1-lb. each; they are sometimes made larger to hold as many even as thirty sections; but it has been found that with our hives those with twenty-one sections are the most convenient.

On the Dadant Hive twenty-seven would go very well. The rack consists of a frame  $\frac{1}{4}$  to  $\frac{3}{8}$  of an inch

\* The engravings illustrating this article are taken from Mr. Cowan's *British Bee-keeper's Guide Book*. The numbers of figures in the book are retained.—Ed.

in thickness constructed in such a manner that on it can be placed three rows of sections *C.C.C.*, and that sufficient space be left that the bees can freely pass over the frames and under the sections. Between the sections and on each side of them are placed cross pieces of about  $\frac{1}{2}$  inch square each. These serve two purposes: 1st. The space between the rows of sections allows the introduction of the fingers to remove them; 2nd, they act as supports for the separators *B.B.B.* At one end of the rack placed perpendicular to the frame is a board against which the sections are placed, whereas at the other end a fixed tapered piece with the wedge *A*, serves to press all the boxes together.

The little 1-lb. sections are made from one piece of wood; formerly they were imported from America, but now they are manufactured in large quantities in England, and to judge from the abundance of good poplar, they could be very well made in Switzerland.

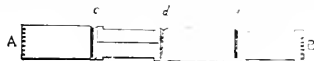

Fig. 25.

They are of wood  $\frac{1}{2}$  of an inch in thickness by 2 inches wide, and when put together they measure  $\frac{11}{16}$  by  $\frac{1}{4}$  inches. The strips of wood before they are folded have appearance of fig. 25. Every piece forming the section has the ends *A B* cut to form a mortise and tenon, and has three cross cuts *c, d, e*, in the shape of a V passing nearly through the whole thickness of the wood. If the piece of wood is bent in such a way that the ends *A* and *B* are brought together and are introduced the one into the other, a section as in fig. 26 is obtained ready for use.

It will be remarked that in the drawing one of the sides is a little narrower than the others; this is to allow the bees to enter the boxes, and when these are placed together a passage of  $\frac{1}{8}$  of an inch is obtained. The 1-lb. sections have a similar passage at the top, because sometimes it is found that two or three tiers of sections can be conveniently worked on the top of each other. The 2-lb. sections are  $6\frac{1}{2}$  by  $5\frac{1}{2}$  by 2 inches and work in exactly the same way.



Fig. 26.

Each little box must be provided with comb-foundation, and for this purpose extremely thin foundation should be used, otherwise the comb will not be fit to eat. The foundation which we use for this purpose is nearly as transparent as glass, and measures about 12 square feet to the lb.

It will be seen by fig. 26, that between each row of sections there are separators *B* which require an explanation, as they play an important part if uniform sections are required. If the combs when finished had not perfectly even surfaces and were not of an even thickness, the comb of one box would encroach upon the space in the other, and there would be a difficulty in packing them. Some sections would weigh more than 1-lb., whereas others would weigh less, and the sections would no longer present the same neat appearance, or uniformity. All this is avoided by using separators. These are generally made of tin and should be narrower than the sections by about  $\frac{1}{8}$  inch at the top and bottom. The wood of which the sections are made being  $\frac{1}{2}$  of an inch thick, this leaves a passage of  $\frac{1}{8}$  of an inch. This has been found a suitable space to leave, for if more space be left the bees would lengthen the cells at this place and if less it interferes with their passage in the sections. It has also been noticed that these separators hinder the queens from entering into and depositing their eggs in the sections. The thickness of combs also tends to prevent the queen from laying in them.

(To be continued.)

## ASSOCIATIONS.

### BRITISH BEE-KEEPERS' ASSOCIATION.

Mr. F. R. Cheshire having found it desirable to reconstruct his Lecture, 'Honey as Food,' delivered at the *Converzazione* on April 16th, we give inserted to the following tract on the same subject prepared by him for circulation at the International Health Exhibition.

### HONEY AS FOOD.

In the earliest ages honey formed a most necessary part of the food of man; and it is to be greatly regretted that it should have been so sadly overlooked in our own country since the introduction of sugar, which began to reach us in quantity about the middle of the seventeenth century, in consequence of Englishmen taking up in earnest the growth of the sugar-cane in Barbadoes. But although sugar has so completely become the substitute of honey, it has not by any means so completely replaced it, since the latter has claims as a food which the former does not possess; while in addition who will deny to honey, if pure, a flavour and character which often will make it a delicacy where sugar would but nauseate?

Honey is not made by bees, but is secreted in tiny quantity by blooms, especially by those of sweet scent, the perfume, indeed, being often in part derived from the honey itself lying in some deep recess in the flower, and inviting the visit of the bee, with its long and wondrously formed tongue, to gather for its own needs and for those of its home, and supply also the table of man with a fragrant sweet.

The bee is full of wonders, and its industry and activity have constantly called forth admiration and surprise. Its instinctive forethought in providing for winter, its self-sacrificing devotion, inducing it to labour without cessation (for it gathers honey by day and builds comb by night), have pointed many a moral, and often shamed the idle and indifferent. But all this energy, in whatsoever form presented, is an energy which it derives direct from the honey which it consumes. For we must remember that all food subserves two purposes, or one of two: it either builds up the material of the frame, when we call it a tissue-former; or it supplies heat and energy, i.e. activity of every kind. It is as a heat-former or energy-producer that honey helps the bee, and us also, if we are only wise enough to take it as a food, for in the little insect it accomplishes the same ends precisely as it would accomplish in the human system.

### DIGESTION.

All foods, if not already soluble (meltable) in water, have to be so altered within us that they become dissolved, and we call this solution digestion. Starch, for example, which forms five-sixths of our daily bread, is utterly useless to us while it remains as starch, because of its insolubility; but in the act of chewing, the saliva which we add to our bread begins to convert the starch into a sugar\* very much like to the sugar of honey, and so renders it soluble in order that it may in due course be carried into our blood, and there do the work of giving us power or heat. Cane-sugar, in like manner, although soluble, requires attention, and this alteration is also brought about by contact with the saliva, and the result is a sugar, as in the previous case, nearly identical with the sugar of honey. Honey, on the contrary, or the sugar that we find in grapes, is already in the condition for absorption or assimilation, and really no kind of work has to be performed upon it before it is actually rendering us service as a force- or heat-producer. It is a law that no force can be manufactured; it must have an origin. It must be paid for by the using up of some

\* There are several kinds of sugar:—Cane sugar, milk sugar, grape sugar, &c.

other force equal to it. So it is clear that when work has to be performed, it may be in the alteration of an article of diet a certain loss of energy is sustained. The superiority of honey in this is manifest, and we can understand why Sir William Gull has stated that grapes (the equivalent of honey so far as their sugar is concerned) have a very immediate effect in relieving a sense of fatigue.

It will be asked, then, if honey gives energy, where does it obtain it? The growing plant takes in power, coming to it in the form of heat and light from the sun. This heat and light do work. They are a gift of force to the plant, and enable it to produce foods (which are but power in a stored condition) for itself, or for animals which may in turn consume the plant wholly or in part. In this lies the energy of all food. Science has made clear that the great forces at work in the sun, and there expanding themselves, reappear with us in part as sun influence. This influence disappears as plants grow, and so form foods; and as these foods are broken up during the activities of animals, those forces are again manifested. The glow in our veins felt while we take exercise is but the result of the breaking up of food, possibly honey, which honey was formed at the expense of sun-heat. That glow, then, is but a reappearance, after many changes, of a tiny fraction of some bygone splendour of the King of Day.

#### PURE HONEY.

If honey, then, as a food be a giver of warmth to the system, a quickener of nervous and muscular energy, and a supporter of all vital functions, how important it is that it should be obtainable in a pure condition! It is not too much to say that modern improvements in bee-keeping have not only greatly augmented the yield of honey, but that they have given it to us in a purity formerly unattainable. The hive, as the home of the bee, has carried on within it the many processes connected with the deposition of eggs, the feeding of the young, commonly called the larvae, and the storing of food. Nature has favoured the bee wonderfully in that her nursery work has no uncleanly accompaniments, but still the tramp of the busy throng, wear, tear, and repair, interfere with that matchless purity of honey-comb to be seen in some of the exhibits made by the British Bee-keepers' Association, because in these the honey has been stored in chambers separate from the body of the hive. Pollen gathered by bees from the anthers of flowers, and which is their natural tissue (or flesh) former, is in this manner kept away from any contact with our honey, and the comb is finished with a surface as dainty to the eye as the petal of a lily, with the additional virtue that its more forcible appeal is not to the eye but to the palate. The little boxes filled with this beautiful comb, flat and white, are as portable as a packet of tea or a cake of scented soap; and if laid on their sides in a dish, and carefully cut round with a sharp knife, will leave the comb undamaged, to form perhaps a novel but certainly an attractive decoration at dessert. Comb thus eaten is always enjoyed greatly by young people, and the small quantity of wax it contains can be refused as would be a grape-skin.

#### EXTRACTED HONEY.

Some may prefer honey free of the comb. In former days this free honey was unhappily often carelessly or ignorantly prepared, and contained impurities which did not make it more appetising while they predisposed it to ferment; but these days have passed away. Draining and squeezing (a term too suggestive of handling) have given place to the process of extraction, a plan by which the comb containing the honey is rapidly whirled round in a box or cage of wire cloth. The honey by centrifugal force is thrown out free of every impurity, and can be drawn off into bottles, often of a delicate straw tint, and perfectly bright from the first. It must be here stated that the tint of honey much depends on its source.

The apple, raspberry, clover, lime-tree, and heather, by example, produce honeies distinct in density, colour, aroma, and perfume, so that a somewhat strong tint is no evidence of impurity; indeed, adulteration so constantly practised with foreign honeies is very generally made a means of giving the article, possibly a mere mixture of corn syrup, colouring matter, and chemical flavouring, the appearance of honey of especially high quality. The British Bee-keepers' Association has been doing good work in seeking to expose imposition, and in giving encouragement to the honest producer. America, unfortunately, has sent us many mock honeies, 'delicately flavoured,' no doubt, but the mixture has not the incommunicable aroma which is honey's birth-right—the outcome of the dainty flavour contributed by every bloom which has yielded its nectar to the little busy gatherers. The milk of flowers is honey, and the magic of science can never get even a distant approach to it out of rags\* or starch, although aided by subsequent additions made in obedience to the recipe of the very 'utest Transatlantic chemist. It is, however, matter for congratulation that since the British Bee-keepers' Association has been active in our midst, in no instance has honey of English growth been known to be put up on the market in an adulterated condition.

In some cases, especially where honey has been exposed to a low temperature or has been long kept, it will lose its semi-fluidity and transparency, and is then said to be candied. This frequently happens with honey of the highest quality. The change is due to a part of the sugar having undergone crystallisation, but of course all the food and health-giving properties remain unimpaired. To restore it to its original state, if this be desired, it is only necessary to place the vessel containing it in warm water. The crystals rapidly melt and the clear and liquid condition will remain for some considerable time.

In conclusion, honey contains sugar in the form most suitable to assimilation. On this very account it is desirable to take it in combination with some less readily absorbed material. 'Bread and honey' has a time-honoured memory, and is a combination as agreeable to sound physiology as it is to the sense of taste. Children with rapidly developing frames and irrepressible activity instinctively feel the value of sugars, and amongst these honey takes a place second to none, so far as the needs of the frame are concerned, whilst its aroma gives it first place on the list. The presence of a minute quantity of an animal acid lends in addition a medicinal value, which in cases of sore throat and some other ailments is well-nigh universally recognised, while the Medical Council of Great Britain recommend the use of honey in no less than seven distinct pharmaceutical preparations.

#### HONEY IN COOKING.

Choice and delicate fruits laid in honey may be for a long time preserved without loss of their beauty of form; and since honey imparts its characteristic flavour to articles with which it may be mingled, it commends itself as an ingredient in biscuits, cakes, &c., for which some recipes are appended. We understand that at the suggestion of the Rev. V. H. Moyle, the justly celebrated firm of Huntley and Palmer are about making biscuits with honey on a large scale. Such a firm happily requires no guarantee for the genuineness of its manufactures; but as, we presume, in this case the Association will endeavour to secure the large quantity of honey required from producers who guarantee their honey, assurance is doubly sure.

*Honey Cake.*—Honey 1 quart,  $\frac{1}{2}$  lb. fresh butter, juice

\* Rags have been employed in making syrup by chemical means, and there is a somewhat amusing instance on record in which used pawn tickets were passed through this singular conversion. In America, however, maize or cob corn, as it is termed, is almost always the source of these chemically derived syrups.



of 2 lemons. Grated nutmeg to taste. Warm sufficiently to soften the butter, and mingle by hard stirring. Mix from  $1\frac{1}{2}$  lbs. to 2 lbs. of flour to make a dough stiff enough to roll easily. Beat well with the rolling-pin until the dough is compact. Make into a sheet  $\frac{1}{2}$  in. thick, cut into cakes with a floured cutter, and bake on slightly buttered tins.

**Honey Lemon Cake.**—1 cup butter, 2 cups honey, 4 eggs well beaten, 1 teaspoonful essence of lemon,  $\frac{1}{2}$  cup sour milk, teaspoonful of soda, flour enough to make it as stiff as can well be stirred, bake at once in a quick oven.

**Honey Fruit Cake.**—4 eggs, 5 cups of flour, 2 cups of honey, 1 teacupful butter, 1 cup sweet milk, 2 teaspoonfuls cream of tartar, 1 teaspoonful soda, 1 lb. raisins, 1 lb. currants,  $\frac{1}{2}$  lb. citron, 1 teaspoonful each cloves, cinnamon, and nutmeg; bake in a large loaf in a slow oven. This will be nice months after baking as well as when fresh.

**Honey Sponge Cake.**—1 large coffee cup full of honey, 1 cup of flour, 5 eggs. Beat yolks and honey together, beat the whites to a froth; mix all together, stirring as little as possible; flavour with lemon, juice or extract.

**Honey Preserves.**—All kinds of fruit made into jam with honey instead of sugar are nice. For grapes, pick from the stem and pack into a jar until it is full, then turn cold honey over them until they are covered well. Seal up without any heat, and keep in a cool place. After a few months they will be found to be delicious.

**Honey Ginger Sausages.**—1 pint honey,  $\frac{3}{4}$  lb. of butter, 2 teaspoonfuls of ginger, boil together a few minutes, and when nearly cold put in flour until it is stiff, roll out thinly and bake quickly.

**Milk and Honey.** Take a bowl of milk, and break some light wheat bread, and also some white comb honey into it. This is delicious, the proverbial 'milk and honey' of the ancients.

**Cheap Honey Tea Cake.**—1 teacup of extracted honey,  $\frac{1}{2}$  teacup of thick, sour cream, 2 eggs,  $\frac{1}{2}$  teacup of butter, 2 cups of flour, scant  $\frac{1}{2}$  teasp. of soda, 1 teasp. of cream of tartar; flavour to taste.

**Honey Paste.**—1 cup honey,  $\frac{1}{2}$  cup white or yellow wax, 1 cup lard; melt together, then take it off the fire and stir till cool; perfume with rose or violet, and keep in cups, well protected from the air. For keeping the hands from chapping, rub on a little, after dipping them lightly in water. It softens them after hard work.

The intelligent cook will of course not wholly rest on cut and dried recipes, but will perceive at once that wherever cane-sugar syrup would be admissible, there honey may be substituted, and that very frequently with great advantage in point of flavour; while the confectioner will recognise that honey in combination with gelatine, and possibly glycerine, may be put into the most fanciful forms, which will at the same time retain the three most desirable qualities, of extreme digestibility, considerable nutritive value, and very agreeable delicate flavour.

#### GLoucestershire BEE-KEEPERS' ASSOCIATION.

Mr. C. Brown, of Bewdley, expert to the British Beekeepers' Association, gave a lecture in the Infant School-room at Fairford on Thursday evening, May 1st. Captain Melbourne presided.

Mr. Brown displayed some very fine diagrams of the physiology of the bee, and gave a full explanation of them and also of the habits of the queen, worker, and drone, and gradually unfolded the mysteries of the hive, particularly with regard to the government of the bees, sexes, and progress of the eggs, queen-rearing, &c. He then explained the proper management of bees, the extractor, guide-comb, &c. He also very forcibly condemned the barbarous custom of killing the bees in the autumn.

In my former entreaty for some one to undertake the starting a Bee-keepers' Association for this county I said

that I could procure ten or twelve members in the Fairford district; and I am glad to be able to say that I have prevailed upon twenty-five to become members, and hope to have a few more yet. If the other twenty-five towns in the county could do likewise, we should make a good substantial Society.

I think we are highly favoured in having such a man as the Right Hon. Lord Sudeley for President, as a good head has much to do with keeping up the interest of such concerns; and he is doing much good for the country by his example, and I hope that his undertaking will prosper, and that the blessing that Jacob gave to his son Joseph will rest upon him.—J. Cook, Fairford.

Mr. Zachary writes:—

It may interest your readers to hear that I have just given my seventeenth receipt of membership to the above Association, and numerous others have promised to join. I think that this is very satisfactory, as the Association was only started on 20th March in this year. I attribute this success to the thorough way in which the local secretaries have worked their districts, and to the interesting lectures which the Central Association have given us. Members intending to join should send their subscriptions in at once, as we are arranging now for the distribution of the *British Bee Journal*.—Wm. ZACHARY, Hon. Sec., Cirencester, April 12th.

#### BUCKINGHAMSHIRE BEE-KEEPERS' ASSOCIATION.

The Buckinghamshire Association has been holding important meetings in the northern division of the county, at which the County Secretary has attended. Amongst other centres at which meetings have been held, Wotton has been visited, and we are glad to learn that Mr. Baldwin delivered a lecture there to a well-attended meeting, chiefly composed of mechanics employed by the London and North Western Railway Company. Considerable interest appeared to be taken in the subject, and we shall hope shortly to hear that the Buckinghamshire Association has made good progress in inducing these artisans to adopt modern bee-keeping. So intelligent a class of men are almost sure to prove successful bee-keepers, and their experiences will, we feel sure, promote bee-keeping amongst the working classes generally.

#### SUFFOLK BEE-KEEPERS' ASSOCIATION.

The Annual Meeting of the members of the Suffolk Bee-keepers' Association was held at the Town Hall on Tuesday, April 22. The chair was occupied by the Rev. R. A. White, and amongst those present were Lord John Hervey, Mr. C. P. Ogilvie, the Rev. W. S. Walford, the Rev. S. Hoole, Mr. G. A. Garrett, Mr. J. A. Smith (Akenham), Rev. W. F. Clark, Rev. W. Harrison (Wickhambrook), Mr. E. R. Turner, Mr. R. Harding, Mr. Pollard (Laughley), and Mr. H. Kerridge (secretary), Mr. A. Harwood, Mr. W. Burleigh (Theberton).

Mr. Kerridge (the Secretary) presented the annual report, and the financial statement. The numbers of the Association's members were increasing, and bee-keeping was becoming extensively practised in the county. The Association's bee-bent had attended various horticultural and other shows in the neighbourhood during the year. The Association's show at Ipswich at the close of the last season had been one of the best held under its auspices, and the honey fair had afforded an excellent medium for the disposal of the produce. The financial statement showed subscriptions of the patron, Sir Richard Wallace, Bart., M.P., the Ex-Mayor (E. R. Turner, Esq.), the Rev. R. A. White, and the general body of members to the amount of 26*l.* 5*s.* 6*d.* The receipts from the show and honey fair, commissions on

sale of honey, &c., 10*l.* 8*s.* 8*d.*; total, 45*l.* 17*s.* 2*d.* The expenditure showed, including the payment of 6*l.* 14*s.* 3*d.* on the balance of 10*l.* 8*s.* 8*d.* due to the treasurer for the year 1882, payments for advertising, prizes, hire of room, fee to the British Bee-keepers' Association, and preparations of the annual show, a total of 50*l.* 0*s.* 10*d.*, leaving a balance due to the treasurer of 10*l.* 3*s.* 8*d.*

The report was adopted.

Sir Richard Wallace, Bart., M.P., was re-elected patron, and Lord Rendlesham, M.P., was elected president of the Association for the ensuing year. Lord John Hervey and Sir George Broke-Middleton, Bart., C.B., were elected vice-presidents. The Rev. G. Langley, the Rev. W. S. Walford, Mr. E. R. Turner, Mr. J. A. Smith, Mr. C. P. Ogilvie, Mr. A. Dix, Mr. J. Gilbert, Mr. A. Harwood, and Mr. G. A. Hempton, were re-elected as members of the Committee, and the names of Mr. Harding, Mr. B. Scott, and Mr. E. L. Fison were also added to the Committee. Mr. H. Kerridge was re-elected secretary and treasurer.

#### MONMOUTHSHIRE BEE-KEEPERS' ASSOCIATION.

On Friday, May 9th, the above Association was formed. The meeting was held in the Borough Court, Monmouth. It was well attended, a large proportion of the audience being ladies. The meeting was addressed by the Rev. H. R. Peel on 'Organization,' and by Mr. Brown, expert for Worcestershire, on 'Bee-keeping.' The Rev. James Oakley, Llanishon Vicarage, Chepstow, has kindly consented to act as hon. secretary; and it is much to be desired that all bee-keepers in Monmouthshire should lose no time in placing themselves in communication with that gentleman, and in enrolling themselves members of the newly formed Association.

The Rev. H. R. Peel is now engaged in a tour through the counties of South Wales, with a view of giving assistance to those who are promoting County Associations in Glamorgan-shire, Pembroke-shire, and Cardigan-shire.

#### NOTTINGHAMSHIRE BEE-KEEPERS' ASSOCIATION.

A meeting was held in the Exchange Buildings, Nottingham, on Wednesday, April 30th. In the absence of Lord Newark, who had promised to be President of the Association, the chair was occupied by the Rev. H. P. Ling; the Rev. H. R. Peel, and Mr. J. Huckle, Secretary of the British Bee-keepers' Association, attended the meeting on behalf of the parent Society. The Rev. A. H. Halley reported that he had corresponded with upwards of eighty residents of the county, most of whom had promised to support the Association. The following resolution, moved by the Rev. H. R. Peel, and seconded by Mr. Beeson, was carried unanimously, viz., 'That it is desirable that a Bee-keepers' Association be established for the county of Nottingham, and be affiliated with the British Bee-keepers' Association.' The Rev. A. H. Halley was unanimously elected Hon. Sec. pro tem., and a representative committee was formed, including several ladies. It was resolved that meetings be held in various parts of the county, and the Central Society be requested to send a lecturer to address these meetings.

#### CUMBERLAND BEE-KEEPERS' ASSOCIATION.

Considerable progress towards the formation of an Association for this county has been made, and we hope to be able to report in an early issue that the efforts of our Cumberland friends have been crowned with success.

## Correspondence.

\* \* \* All Correspondents forwarding Letters for insertion in the Journal, Reports of Associations, Shows, Meetings, Echoes from the Hives, Queries, &c., are requested to direct their communications to 'The Editor of the "British Bee Journal," c/o Messrs. Strangers & Sons, Tower Street, Upper St. Martin's Lane, W.C.'

#### HONEY MARKET.

At the close of Mr. Cheshire's interesting lecture on 'Honey as Food,' I exhibited to those present part of a honey cake, and also honey biscuits which had been manufactured for me by Messrs. Huntley and Palmer, of Reading, the celebrated cake and biscuit manufacturers. Part had been shown and given away at an Art and Industrial Exhibition opened at Theale on Easter Monday by the late high sheriff of Berks. I showed this cake and the biscuits because there is a practical bearing on the whole question of bee-culture arising therefrom.

Messrs. Huntley and Palmer are manufacturing now for the general market biscuits called 'Honey Drops,' and have used and intend using only pure, unadulterated British honey. They will require some *two tons a-week*: and as a depot is being formed in Reading to receive pure honey for this purpose, I shall be glad if all interested in bee-culture will make this known; also if they will ask their grocers or confectioners for these biscuits, and order them if they have not got them in stock. Mind, Huntley and Palmer's 'Honey Drops.'

I shall be glad to hear from all bee-keepers and secretaries and members of bee-keepers' Associations who have honey for sale; and I trust that such a demand as this will operate in a wholesome way on the general question of bee-culture, and lift bee-keepers out of little trifling differences about forms of hives, &c., into the broader question how to get the most honey from the little busy bee.

Messrs. H. and P. will not take any notice of any small communications announcing that Brown, Jones, or Robinson, may have 6 or 10 lbs. for sale; but vendors of honey, either in large or small quantities, may write for information to—

V. H. MOYLE,

Brook House, Burghfield,

Near Reading, Berks.

For a *bona fide* article market price will be given throughout the year.

#### PRIVILEGES OF COUNTY ASSOCIATIONS.

As a subscriber to your very valuable bee-keepers' help, I beg you will afford me a small space to answer some of the 'Privileges of County Associations,' set forth from time to time in the *Journal*, so far as regards this district. Residing in Lincolnshire, where the first County Association was formed, I as an amateur, desiring to get the benefit of unity, it being strength, and to enjoy and help on the privileges, applied to the local secretary of the County Association to become a member, when he told me, that, although he would take my subscription, he must first inform me that the privileges he could offer were far from what were represented as members' privileges; that the Association had not had a report since 1880; and further, that no visit of an expert, and no inducement to get a gathering of bee-keepers properly belonging to the Association, had been made for some time. The only privilege he had to offer was the use of an extractor. Is that a fair inducement to join the Association or encourage people to start bee-keeping? I am still anxious to make an unit in the unity, but we can scarcely run into the trap as now set. I am afraid the result will be, that unless matters are

mended, very few in this district will pay another year's subscription to the Lincolnshire Association. There is a local show annually now, at which bee-keeping is taking a prominent part, in our own district centre (Louth), so that the money and interest of the bee-keepers will go to help it instead of to the County Association.

I hope there will be an explanation to the information afforded me, and that the powers of the Association may make a satisfactory defence, and at any rate mend matters, so that enthusiastic amateurs like myself may obtain what a few seem now to want to keep to themselves. Trusting that events will meet me soon become a member of the L. B. K. A., and that it may flower again in this district, I am, &c., F. W. RIGGALL, *Louth*.

#### FROM 'HAMPSHIRE HOG.'

Mr. Editor, *Pachydermatous!* What a mouthful! You seem to want to air that classical knowledge which your biographer descants upon. I dare say it is getting rusty. Not so rusty as Edward's, though. No, H. V. E., 'When in death I calm recline' (as the Irish poet says, who must of course be a favourite of yours), the heart you will bear to my mistress will not be a *Bull's* heart. My flesh will not be *bovine*, but *porcine*. I shall be Pork, not Beef. *Pachydermatous*—pig-skinned! I can't get over that; I am crushed. I'll go over to Ireland and set up a bee-farm with Lett and 'Paddy.' You don't seem to like me here. I only tell my friends all their little faults and failings, and yet,—

'Everybody says I'm such a disagreeable man,  
And I can't think why.'

Refer to Mr. George Grossmith, Savoy Theatre, Strand. Good-bye, Edwards; good-bye, Mackworth; good-bye, Derby!

I must admit, however, Mr. Editor, that your idea is better than mine. There is no need for Scotland and Ireland to be afflicted if they will only do their duty. You keep your eye on Scotland; I'll wake up Ireland.—Yours, gruntingly, HAMPSHIRE HOG.

#### COUNTY REPRESENTATIVES.—

##### A SUGGESTION.

As you invite discussion on sending representatives from distant County Associations, I venture to make a suggestion. Let the County Associations make their Presidents their representatives. They are mostly noblemen and ladies, who are continually in London, and could attend the Quarterly Conference with very little trouble. It would also make them sensible of their position as Vice-Presidents of the Association.—JEMBO.

#### DISTRICT SECRETARIES AND LOCAL ADVISERS.

As some confusion has already arisen between 'District Secretaries' and 'Advisers,' may I suggest that the former should be known as *District Secretaries*, and the latter, whose office is quite distinct, and necessarily extends over a smaller area, as *Local Advisers*? It is not yet too late to establish this distinction in names, and may in future save much confusion.—J. LANGEN SEAGER, *Hon. Sec. H. B. K. A.*

#### QUEEN INTRODUCTION.

In reply to Mr. Simmins's letter in your issue April 15th, on this subject, kindly allow me a word or two on one or two points. I am accused of harshly condemning his system. I am not aware that I have used a single harsh expression, and beg to assure Mr. Simmins that nothing was further from my intention. I have written against

his system, simply because I felt that it was calculated to mislead the novice and the inexperienced; and I must be allowed to hold the same opinion still, although he has qualified it by allowing the use of smoke. This system, as is well known to many apiarists, was introduced in America some years ago, and proved an utter failure. Indeed, I do not know that any statement more adopted to cause chagrin and disappointment to the mere novice in queen-introduction could be framed than such as the following: 'A queen can be introduced direct and absolutely without risk'—in full capitals; and again in capitals: 'A queen on a comb parading unconcernedly among her own bees would be taken no more notice of than the others'—that is to say, when introduced to an alien colony without 'disturbance!' I have practised queen-introduction for more than thirty years, and can fully realise the danger with which such statements are fraught to the inexperienced. I have no personal acquaintance with Mr. Simmins, and can therefore have no quarrel with him personally, but against such statements, promulgated and made public, I claim the right to lift up my voice on behalf of others. I will only trouble you with one more reference.

Mr. Simmins charges me with *commending* Mr. Jones's plan of introduction by means of chloroform. I have not 'commended' it, neither have I recommended it. In fact, I have given it neither praise nor blame, as anyone may see by referring to my pamphlet. In the appendix I have simply given Mr. Jones's system stated in his own words, as a process by which he claims to have introduced fifty queens in fifteen minutes. It is true that Mr. Root, the editor of *Gleanings*, and author of that excellent book the *ABC of Bee Culture*, remarks on Mr. Jones's plan: 'It is my impression that one hundred queens may be turned loose at the entrances of one hundred queenless hives without losing more than five per cent on an average if it is done during the honey season, and towards the close of a day that has furnished abundant forage. Where queens are plentiful and apiarists pressed for time, I should recommend this plan of introducing; but it requires, as friend Jones wisely remarks, *considerable experience to know just the circumstances under which she will be accepted.*' And it is true that I have stated with regard to Mr. Root's words: 'These words exactly express my own views and experiences, and so far from advising the *inexperienced* to try any of the nostrums recommended as invariably successful, to their almost certain chagrin and loss, I would say, Purchase queens at the head of small nuclei, and endeavour to build up, by paying a little more for them, rather than run a certain risk of losing all.' This is very far from commending Mr. Jones's plan as a general method of introduction even to experts, to say nothing of novices! Nevertheless, I have no fear of the foul brood, so much dreaded by Mr. Simmins, as the result of this application of chloroform. I have repeatedly administered chloroform *in moderation* to bees under various circumstances, but have never had a case of foul brood in my apiary during the forty years I have been a bee-keeper. Indeed, I fully believe, with Mr. Cowan and others, who have studied the subject of foul brood scientifically, that it cannot arise spontaneously—that it can be communicated by the spores alone—the *micrococci*—which may be floating in the air, or conveyed by the bees themselves. *Ex nihilo nihil fit.*

I do not believe that it is 'a fact that foul brood is alarmingly on the increase in America,' as Mr. Simmins asserts. I see all the principal American periodicals on bee-culture, and have not yet discovered this fact. At all events, to characterise an experiment of one American apiarist amongst thousands, as capable of causing 'an alarming increase of foul brood' is, to say the least, gratuitously to hyperbolise. Again, by Mr. Jones's plan the bees are not rendered *fully comatose*, but simply brought into a *sleepy* state; hence all Mr. Simmins's fears

as regards 'stupified bees choking the entrance,' 'state of suffocation,' 'killing a large portion of the delicate larvae,' &c., &c., may be dismissed as 'chimeras dire' existing in his brain alone.

It is my intention to give the plan a full trial, and I shall hope to report results in your pages at some future time. Meanwhile—*pace* Mr. Simmins—I must beg to be excused if I prefer to his own the dicta of men like Messrs. Jones, Benton, and Root, who handle, perhaps, thousands of hives and queens where an English apiarist manipulates one.—GEORGE RAYNOR, *Hazleleigh Rectory, April 16th, 1884.*

#### PROPER NAMES OF THINGS.

A step leading to correct nomenclature is the first we ought to take, if we are desirous to advance any practical science such as that of apiculture to a high degree of perfection. Technical terms must be laid down authoritatively by members of the same by a body like the B. B. K. A. In writing of bees, hives, &c., our explanations should be clear and decisive. May I suggest a meeting of that Association, and may I propose a few abbreviated terms, just to explain my difficulty and my argument? Sections on top of hive are called 'supers,' but cannot be so termed when in or near the body of hive. As *super* is a Latin name, we might adopt, or the B. B. K. A. might improve, some of the following: 'Right laterals,' for sections on right side; 'Left laterals,' for those on the left; 'Collaterals,' those in body of hive; 'Utroquals,' on both sides at the same time; 'Undquals,' on every side; 'I'terials or Posterials,' on farthest side; 'Supers,' those on top. And, supposing the ideal hive to fall due south, we can call those frames parallel to the front side of hive, 'East and West Frames;' and those parallel to sides, 'North and South Frames;' 'E. and W., and N. and S. Frames.' This nomenclature can be easily added to, and the sooner we fix an intelligible vocabulary the better.

As an instance of the confusion caused by a want of proper names, read our esteemed writer Mr. Simmins' letter, p. 100, *B. B. Journal*. In four different places he uses four different expressions to describe one and the same position of frames. Locke says that almost all our errors are caused by words.—UNIQUE, *Hortown Rectory, co. Wexford.*

#### FUEL FOR THE SMOKER.

As a good fuel for the smoker I recommend dry cowdung: it is easily obtained, perfectly clean to handle—burns like tinder and slowly; there is no danger from sparks flying out, and it gives a fair amount of smoke with a peculiar smell much disliked by all insects. Start the fire with two or three hot ashes and put on them a few pieces of the fuel broken small: when well alight the barrel may be filled to the top, and by adding more as it burns down, the smoker can be kept going for any length of time.—D. R. MACQUEEN, *Kamo, New Zealand.*

#### REMOVING SUPERS DURING BAD WEATHER.

In reading the Rev. F. S. Selater's article on 'Feeding and Feeders,' on p. 130, I see he recommends removing supers when unfavourable weather sets in, and then to feed the bees; will he kindly state how he manages, (providing it is wet and cold), to take off, say ten or twenty supers, and get the bees out of them, so that they could be put away till the weather again becomes favourable? Some years ago I saw it recommended in the *Journal*, but never could see how it could be done, so seeing it brought forward again, I could not refrain from asking how it is done.—JOHN WALTON, *Leanington, Honey Cott, Weston.*

#### EARLY SWARM.

I have read with interest the remarks on page 130, about an 'Early Swarm.' It may possibly be of interest to some to hear that on the 16th March, which was a real mid-summer day for warmth, a swarm was reported to me by the owner. I made very particular inquiry about it then, but all the information I got was that he had had a swarm, that they settled in a neighbour's garden, and that before he could hive them, which he described as about a quarter of a peck, they took flight again and went back to another hive of his own bees and joined them. The circumstance caused considerable comment, and was, I am informed, the subject of reference from the pulpit, but unfortunately I did not happen to be present, but I have had many inquiries as to the probable cause.

A short time after, happening to be near, I took the opportunity of examining the parent hive, which, I was informed, still contained bees. It only required a tap to prove the mistake. I turned it up, and only found a few robbers on some sugar-cake, and have no doubt it was a 'hunger swarm,' as the hive was clean and about three parts filled with last year's comb.—J. HAM, *Redditch.*

#### BLACKS *v.* LIGURIANS.

For some weeks past I have been thinking of giving the readers of this *Journal* a short sketch of what has recently appeared in the *Journal of Horticulture* against Ligurians. But I see by last *Bee Journal*, p. 154, that I have been anticipated by Mr. H. V. Edwards, who has drawn attention to what has appeared in your contemporary condemnatory of Ligurians as 'honey-leavers,' as Mr. Edwards puts it, and very properly too: for what matter how much they gather if they manage to consume it all before the autumn? Had Mr. A. Pettigrew been alive to have read the condemnation of Ligurian bees, how delighted he would have been, as he was a strong foe to them years ago, as any one will see by referring to his papers in back volumes of *Journal of Horticulture*. But, as Mr. W. B. Carr said in his paper opening the attack on the Ligurians, Mr. Pettigrew had not much weight, as he had not tried the bees himself, and therefore could not speak from experience. But others have written for our benefit and warning too, and would have us beware of Ligurians, especially in our cold climate. All who have written their experience of Ligurians in the *Journal of Horticulture* for this five or six weeks have condemned them, and would prefer the black.

'Hallamshire' seems to be annoyed with Mr. Carr for condemning all foreign bees, as he has found that the Syrian bee has proved a perfect success with him, and, in fact, it is the coming bee, and no doubt will be named the Anglo-Syrian bee. Still I fancy that bee-keepers in future will be more cautious about procuring novelties in the shape of a thing that exercises such influence as does a queen-bee. As I do not know geography well, I cannot say what influence climate has in favour of 'Hallamshire's' Syrians; but I fancy it is better than what poor Paddy has at home. I know six different persons round here who have within these last three years tried Ligurian bees, and one and all condemn them as a failure for this part of the country (Ulster). One gentleman calls them the all-bees-and-no-honey variety; and no doubt experience has taught me it is too true. My stock of them this spring was only one pure queen (home-bred); and to convince your readers I am sincere, I caught her amidst a happy and prosperous colony and killed her, and gave her progeny a comb of good blacks' eggs from which to build queen-cells. As I see drones out, so I hope my country will be united, and say no more Ligurians for—PADDY.

### BLACKS v. LIGURIANS, AND OTHER FOREIGN BEES.

Under the above heading Mr. H. V. Edwards asks for my opinion of Ligurians (so-called) and Syrians for surplus honey-leaving. I have given my experience and opinion with the former in *Journal* for Dec. 15th last, page 294, and may further say that I heartily agree with most that has been said against them; neither do I consider their cross any improvement, being vicious and apt to get their surplus by robbing the more industrious blacks; even when there has been a heavy honey glut on, and when this is so blacks never guard their entrances. I have seen Ligurians and hybrids quietly fetching out load after load. Most people who defend them are dealers, or have only jumped at conclusions from first impressions without sufficiently studying them.

I was somewhat surprised to see Mr. S. Simmins, after praising them in the *B. B. J.*, stating in the *American Bee Journal*, page 25, present volume, that the "coming-bee" would have to be bred from blacks in a direct line. Well, I rubbed my eyes, when I read it; but as "Murder will out," the truth slipped out where he had no bees to sell; he was not running down the Ligurians, Oh, no! but he let the "cat out" for all that by the above; and as he lives in the south of England, bee-keepers may form their own conclusions.

I have given my experiences and opinion of Syrians and their first cross with blacks on pp. 50, 63, 7, 294, Vol. XI, and 31, Vol. XII, which I see no use to repeat; but by way of variety and "diversion" of which Mr. Edwards is very fond, I will just give the experiences and opinion of another bee-keeper—Mr. C. N. Abbott, who got the first Syrians which came to this country, and who made the 20% profit from one hybrid stock of these bees, besides winning a prize with twelve 2-lb. sections of their honey. Mr. E. calls this "the oft-repeated, but solitary case;" very likely, but the variety of Mr. Cheshire, if I remember rightly, was doubted when by liberal feeding and careful management he claimed to foot up a total receipt of 10% from one stock.

If those who have the number of the *B. B. J.* for July, 1881, will turn to page 52, they will see a letter headed, "PROLIFICNESS OF SYRIAN BEES. SOME OF THEIR PECULIARITIES." The writer of this letter is delighted with them. One stock had thrown five swarms; and at the foot, in brackets, signed "Ed.," which must be Mr. Abbott, as he was the Editor at that time, is the following comment:

"Multiplying into six straight away is not bad, and bears out the character they have received for unexampled prolificness. They are a wonderful race, the principle of life being marvellously strong within them; and they have extraordinary qualities in other respects. They are excellent workers; they breed very rapidly, they raise immense numbers of queen-cells, they frequently begin laying when only a few hours old, and in some instances become fertilised before they destroy the royal cells, though they appear to tear out their sisters that are near hatching. To our mind they appear to disprove the Dzierzon theory of breeding pure drones after cross-mating—a theory which never was acceptable to us, and, in fact, is against all other experiences in animal life. The drones that hatch from the eggs laid by virgin queens are uniformly well marked with rich golden yellow, but those produced after mating with black bees are in some cases quite black."

\* The writer is mistaken in this matter, for it is a fact, which I had the honour to discover, prove, and publish to the world in the *Journal*, on pp. 66, 67, vol. xi, that fertile workers live and lay their eggs side by side with laying queens. Thus, if there has been any attempt at queen-rearing from hybrid brood, we shall have hybrid workers producing hybrid drones, and at the same time the queen, if bred from a pure mother, will be producing pure drones; so after all there is no evidence to disprove the Dzierzon theory.—J. H.

"The worker progeny of cross-mated Syrian queens are all well marked, and suggest the idea that the Ligurian bee is a cross of this kind, the unevenness of colour in the Ligurian drones supporting it. As with Ligurians they vary in temper, some of the cross breeds are so terribly fiery that they can scarcely be dealt with, while others are as meek as flies—a fact which appears unaccountable. Our pure Syrians (we have but one stock at the present time) are fairly good-tempered while young, but a nucleus made from them that have done little work, and have grown old, are perfect little "demons," and care nothing for strong tobacco-smoke, though a jet be directed continuously against them. We have hesitated before giving an opinion on their qualities until experience gave authority for so doing, and even now we feel there is much to learn of them. We formed several nuclei from them for queen-hatching purposes, and young Syrians found their way into all the hives in their vicinity; and, having grown old, show their temper on all occasions, while their foster sisters are as good-natured as usual. They are small bees, but their cross breed are larger and the best workers we have, and, singularly, have shown no disposition to swarming."

In addition to the above, on page 48, in speaking of Cyprians, he says, "but the best workers we have ever known are the cross from the Syrians;" and in replying to a query on page 62, he says, "These appear to have the principle of life so strongly developed that probably they could raise queens from brood ready for sealing up."

This last statement is apparently so extraordinary and incredible I should have been inclined to doubt it, had not one of my best Syrian queens hatched from a cell that was like an ordinary cell, with a slightly curved drone-cupping. I saw the cap nibbled half round, so I took a pin and removed it, when out marched a very fine queen. It goes to show that Mr. Abbott at that time was carefully observing these bees, and was quite delighted with them, though at this time he had not made the 20% profit. In November he published his magnificent profit, from which time he seems to have had little or nothing to say about them; but in the early part of 1883 we find him sending out in the name of Abbott Bros. to all known bee-keepers a catalogue containing the following paragraph:

"CYPRIAN AND SYRIAN BEES.—Abbott Bros. have cleared their apiary of the so prevalent pests, and respectfully decline to receive orders for them. They are too fierce for ordinary management, and where introduced are likely to ruin the temper of English and Ligurian bees."

The question which occurs to me is, if they are a wonderful race, with extraordinary qualities in other respects, excellent workers and breeders, and their cross-bred the best workers he has ever known, and as meek as flies, though some of them were fiery—the result of crossing with hybrid Ligurian drones—with no disposition to swarm, how can he honestly call them "troubling pests?" I think all sensible bee-keepers would not object to such pests; the very possibility of having twenty or thirty lbs. of such bees at once in one hive ought to delight the lover of the Stewarton pile.

Mr. Abbott claimed to be responsible for all he wrote in the *Journal* when Editor; and as many of us were subscribers to it then, will he please explain why he wrote a fairly true account in their favour when he had them to sell; and when circumstances caused him to cease dealing in them, he put forth what I consider a mis-leading statement to deter people from buying them?

The matter is a public one; we are all wanting the bees that will give the greatest returns for the least trouble and outlay; and if Mr. Abbott has used his influence to prevent the introduction of them into this country, he ought to give us an "explanation." Bee-keepers have no idea of the trouble and difficulties Mr. Benton has had to experience in giving us these bees. At one time he had to leave his bees just as they were, queen-cells all hatching out, or whatever might require

attending to, and fly with his wife and child to the mountains to save their lives. Is there another man that would have returned to his work, and all for the purpose of giving us the best bees that could be found; and as he has placed these queens at the low price of 22s. each, I see no difficulty in the way of all getting them. Anyway, it is certain no competitor will go out to breed them, to reduce the price by breeding for quantity instead of quality, to supply dealers like they have done with the Ligurians.

I had hoped to show the superior qualities of the first cross with blacks in the 'Bligh Competition,' had the rules made it possible to do so, though this is a very poor honey locality. JOHN HEWITT, *Sheffield*.

### SWARMING.

Judging from the silence of the bee-keepers in general, not responding to the appeal of 'Paddy' Vol. VII, p. 33; it would seem that none are interested in this subject; and yet it appears from much private correspondence that very many indeed are most anxious to know how to manage their bees at this most critical time. I have already shown how I control those stocks working in supers in my large apiary, but now the question appears to be, how to adapt a similar system to those apiaries wherein the number of hives is limited.

'Paddy' rightly says that I did not, in my first paper on the subject, show how to prevent swarming; but a careful perusal would have shown him that my intention was not to prevent, but to point out how bee-keepers need not be halled by, swarming. By following the plan given, I find that any colony, at the swarming point, may be brought so completely in hand that the supers are never neglected; and I more, the old hive gives me no further trouble. Vol. VII, p. 12. I save my self endless trouble by making no effort to prevent swarming by the means generally adopted, and consider that in permitting the bees to swarm under control very much better results are to be obtained, because new swarms work with the most vigour. Neither do I ever remove one or two combs of brood as a preventive. When bees have once made up their mind to swarm nothing but the act of weakening them in that manner will really prevent swarming, and where foundation or empty combs are returned in exchange, these will be worked out and generally filled with honey, at the expense of the sections.

'Paddy' is quite right in considering that blacks swarm less than Ligurians, indeed the former very seldom swarm if the sections are properly attended to. Again, swarming seldom occurs with those stocks run for extracted honey, whatever race of bees we may be working with; but as the subject under consideration is that of preventing increase while working for comb honey, I must return to 'Paddy's' proposition. He does not see how to adapt a non-increasing plan to his apiary of only six hives, and I must say he submits a very extreme case in supposing all would be ready to swarm at the same time. But to get over even that difficulty, I will show what I should do with only *one* hive, if I wanted no permanent increase. Super the bees when strong enough and with favourable weather, and when they swarm (say out of nine frames) return the swarm to their original stand and hive on to seven frames of foundation, but first remove all the combs with adhering bees to another hive, placing the latter close to the old stand, but with the entrance (contracted) turned half round away from the other. All the working force will return to that hive on their own stand, leaving none but young bees to take charge of the nursery or removed brood-combs. The supers are to be placed at once on to the seven frames of foundation, fill up all open spaces below with dummies.

Returning to the nursery, it will be found that

in eight or nine days the first young queen will hatch; destroy the others, and in about another ten she will begin to lay; and now, after three days more, let the hives change places for the following operation. Probably, the young queen will have eggs in no more than two combs (there need not be more if taken in time). Leave those two, but shake all the bees from the rest into the body of the hive; and now return the seven combs recently built from foundation, with all bees, as well as the super, first removing the old queen, and as soon as clear, take the denuded hive right away. We have then again nine frames, and a very strong colony, by giving them all the young bees, just old enough to work, but which would have been of little use to the original hive at an earlier date, especially as the latter had been restricted to seven frames, being all that could be profitably occupied during the three weeks. We have also gained a good young laying queen without losing time, and seven new combs. If the same plan of hiving is followed year after year, it is supposed that more combs will be obtained than are necessary, but I am convinced that if the surplus combs are rendered into wax, it will nearly pay for foundation, while the slight additional expense is as nothing compared with the advantages obtained. Nevertheless, I consider that no system of bee-keeping is complete without extra combs and hives. Good old combs are invaluable, and inferior to foundation only when returning swarms as previously stated, while an additional hive may be wanted at any time.

I would advise no one to insert a virgin queen at the swarming point, as suggested by 'Paddy'; such a proceeding will only result in disappointment and loss, as practical experience will soon convince those who try it.

SAMUEL SUMMERS.

### WIRED FOR FOUNDATION.

The following is a method to fix whole sheets of foundation or broken combs: If the sheets of foundation are cracked or broken, they are made stronger than new; both comb and foundation may be inserted in a frame; *no saw-cut* required. Stretch some No. 26 tinned-iron wire, cut some pieces thirteen or fourteen inches long, see they are perfectly straight; now lay a sheet of foundation on a dummy, or a piece of wood broader than foundation if warped, so its being slightly convex is better high in the centre, about a quarter inch. Take hold of each end of a wire and draw it quickly backwards and forwards through the blue flame of gas - if put in the white flame will blacken it. Now plunge the heated wire in foundation, after a few trials one will hardly tell which side the wire was put in, one wire attached to a six-pound weight will support the weight and fail to draw it. I use six wires to the whole sheet, commencing about one inch from the end, a second half-inch from that, two near the centre, two more at the other end. Now make holes to correspond in top and bottom bar, thread the wires through and twist off. If the frame has saw-cuts three wire-nails driven through at the top of the bar, thread on either side of it and fasten off. If for combs tie knots in the wire, if extra strength is required put snips of wire three-eighths long in the knot. - J. S. BOREHAM, *Colchester*.

### MODERATE INCREASE.

This subject is nearly related to that of swarming without permanent increase. Many say they want all the honey they can possibly get, and great increase as well. There can be no greater mistake than to suppose that such a thing is possible. If we wish for a good yield of honey, our increase must be very slow, and then under the swarming impulse, if we want to obtain the best results. In the first place, proceed as already stated for no increase, but remove the old hive some distance

away, and from this swarmed stock, save all the queens you expect to want, by engaging them as they hatch, on *unsealed* honey (in the same hive). As soon as sufficient young bees have hatched out, form a nucleus with each queen, with one comb of brood, and bees from such hive, with another comb of honey on either side, leaving one young queen in the main hive. Do not force your other hives to swarm, but let them alone, and take only those that come off naturally, first treating them as before, but taking the removed combs and adhering bees to a nucleus with a young laying queen. After a few days, reduce the latter hive to seven frames, and put on a few sections only at first, carrying the surplus combs containing best brood to the next nucleus, and so on. If colonies are built strong in the first place, they remain strong throughout under proper treatment, and the seven combs (for moderate increase) will give better results than any other number, because now having our bees well in hand, we do not want them to produce more brood than is really necessary, while the honey flow continues.

Again, much mischief is caused by very many beekeepers attempting to raise queens before their colonies are really strong, but by adhering to the foregoing only naturally raised queens are reserved, and those from the earliest and best colonies, and in such a manner that there is little diminution of strength.

Of course, if no honey is required for a season or two, the amount of increase one can obtain is almost unlimited, as it is possible to make bees consume all their income in the production of brood; and those who are willing to forego present profits, can soon build up a large apiary. And, on the other hand, under a careful system of management, increase can often be obtained, naturally even long before honey is to be found in quantity, but artificial increase at that time must be carried out with great care, or much harm may be caused by dividing before the bees are really in a fit condition, and this being so, the season will most surely be lost.

S. SIMMONS.

#### THE CULTIVATION OF BEE-FLOWERS.

Kindly allow me to say a few words respecting the cultivation of bee-flora. I think the recommendation of T. H. Buckworth respecting the discontinuance of sowing of seed and planting of flowers for bees cannot be too strongly condemned. In England there are some hundreds of thousands of pounds expended every year in the purchase of flower seeds for sowing, to say nothing of the large amount of seeds collected by persons who make a rule to collect and sow their own seed, and we have only to picture what would be the result of Mr. Buckworth's advice if everybody were to cease sowing seeds and planting flowers. I take it for granted (all things considered) that the contribution of pollen and honey from our cultivated flora is as great as from any source we can mention. I do not for one moment desire to underrate the value of the palm-willow, but I would ask our well-informed bee-keepers that if its cultivation were adopted, as Mr. Buckworth says it should be, whether it would be of one-tenth the value of our flowers. From my own experience, and from what I know of others, I feel convinced that the cultivation of flowers should be encouraged a deal more than it is at present. I live on the outskirts of a county town, in which there are some scores of such small patches of flowers as Mr. B. seems to undervalue, and it is very interesting in favourable weather to watch such large numbers of bees so busy in carrying off the sweets of these small patches of flowers. I have a little garden about the size of that mentioned by Mr. W. Ingram in your issue of April 1st, which I always keep well stocked with most kinds of bee-flowers, such as early spring and late autumn pollen-producing plants, and in the summer I stock it with the best honey-flowers I can get (mostly borage, which is an excellent honey-producing flower),

and I can assure your readers that it affords me great pleasure to see my flowers continually black over with bees collecting and taking into their hives such large loads of pollen without going off in search for it one knows not where. This proves to me the advantage of sowing flowers in every available inch of ground we have. I would advise bee-keepers to sow and plant all the pollen and honey-producing flowers they can.

WILLIAM HOLLINS, *Stafford.*

#### WINTERING UNDER DIFFICULTIES.— HEWITT'S CANDY.

During the last week of October I had some skeps of condemned bees offered me. I hesitated to take them, partly because of the risk of attempting to feed them up for winter so late in the season, and partly because I had only a make-shift hive in which to place them, and no empty combs to spare. However, I decided to try; and I thought it was just the opportunity to test the merits of the candy Mr. Hewitt had lately been advocating in the *Bee Journal* (Vol. vi. p. 119). My hive consisted of four sides of inch stuff, standing on a loose floor-board, which projected two inches all round. I contrived another board of the same size to act as a cover, with a hole in the centre for feeding. In this hive I placed my bees on six sheets of foundation, two of which were partly worked out; and one of these two contained not more than half a pound of sealed syrup. I fed them with syrup for ten days to induce them to work out the foundation, which they did only partially; and they stored and sealed perhaps a couple of pounds of the syrup. Early in November I introduced a frame of Mr. Hewitt's candy placed according to his directions, and also a slab of ordinary candy, made according to Mr. Cowan's recipe, about 6 ins. square and 1 in. thick, on top of the frames, with a stick at each side of it to ensure passage way during the winter. I then packed cork-dust cushions outside the dummies, and another about 3 ins. thick on top of quilt, and supported the flat cover on wooden blocks, so that it stood clear of the cushion below it. I had previously procured some sheets of stout brown paper, tarred them on one side, and, putting two tarred surfaces together, ironed them with a hot iron until the tar soaked well in, and then separated them and put them by. I now tacked these sheets on to the edges of my cover and floor-board so as to make an outer wall of paper all round the hive, and a sheet over the top with overhanging edges and a hole corresponding with the feed-hole. Over all I contrived a very rough-and-ready arrangement to throw off the heaviest of the winter's rain, and allow ventilation through the feed-hole without the entrance of wet. And so I left them for the winter. The hive was in a sheltered corner, or I dare not have ventured upon so flimsy a covering; as it was it answered well.

All through the winter the bees in this hive were extraordinarily active, much more so than any other stock, and I felt very diffident about them. It was with fear and trembling that I removed the wrapper in the middle of February; but, to my delight, the bees were apparently as strong as when they were packed up. Cowan's candy was entirely gone, Hewitt's nearly so, and there was, as far as I could judge, most of the syrup left. I put some more ordinary candy over the frames and replaced the paper wrappings.

During the winter I had prepared a worthier habitation for them of a pattern which I prefer to any other. It is precisely similar in general plan to what Mr. Hewitt has lately been describing in the *Journal*, except that I prefer the half of a Tinsdickler match case (25 by 24 ins. inside, inch stuff tongued and grooved, cost 6d.) to the Assam tea-chest, and have the roof covered with Willbsden eurl instead of felt, and flush at the ends instead of overhanging. This hive is capable of holding thirty

frames, and an indefinite number of sections beside if desired; and so is large enough for two colonies of blacks, or the strongest conceivable stock of foreign bees. (Or other matchboxes can be got 30 ins. long equally cheap.) Into a hive of this sort I moved my bees early in March, at which time all the candy was gone, and only a little syrup left at the top of one frame, and they had a nice patch of sealed brood. There they were, strong and well, covering six frames at the beginning of March just as they did at the beginning of November. Thus I have found that with the help of a frame of hard candy it is possible to do what I presume it would have been folly to attempt otherwise: to put driven bees upon foundation at the end of October in a makeshift hive, and yet get through the winter in first-rate condition.

I have entered very minutely into some details above because I think that success or failure in this matter may be determined by apparently small causes. I hope that others who have tried candy during the past winter will report their experiences, so as to compare notes and arrive at the most reliable results before next autumn.—**HONEY-BEE.**

#### BEE-KEEPING IN THE ISLE OF MAN.

Some time ago I promised to report progress as to how Mr. Drinkwater's efforts were succeeding to improve bee-keeping in the Isle of Man. Early in the year he sent one of Abbott's Copyable hives to a gentleman in Douglas for exhibition, and as a prize to be offered at the Agricultural Show held in August in connexion with bee-keeping. As you can well imagine, the hive was a matter of curiosity to bee-keepers accustomed to the straw skep, and who never saw anything different. Several have turned their attention to the acknowledged improvement. One gentleman in Douglas has made four hives; Mr. Lockerby, at Crosby, has made five bar-frame hives; Mr. E. C. Kerr, of Ramsey, has one of Neighbour's imported ready by the time when his straw skep swarms. Mr. Harrison, of Derby Haven, is about commencing bee-keeping, also in one of Neighbour's bar-frames, and several others have the improved principle in contemplation.

Mr. Moore, of Douglas, has induced many of his friends to take the *British Bee Journal*, and has offered as a prize in connexion with Mr. Drinkwater's a honey extractor; and Mr. Lockerby, of Crosby, 20s., all in connexion with improved bee-keeping in the island.

Many of your readers, I have no doubt, are aware that the Isle of Man is a very favourite holiday resort; and should they this summer visit our beautiful shores, which is only a four hours' sail from Liverpool, any of the gentlemen whose names I have given would be only too delighted to be called on and instructed in the interesting subject of modern bee-keeping.—**MONA.**

#### HINTS TO COTTAGE BEE-KEEPERS.

Feed your bees well in April, and feed them slow in May, And you will have a splendid swarm upon an early day. Place a brick in water, for them to rest and quench their thirst, And if the weather should be cold, just feed the swarm at first: Be careful how you feed them; don't spill the stuff about, Or you will tempt the robbers to come and clear you out. Place a super upon the stock in June, and fix it tight, And soon the sections will be full of honey pure and white. 'Never kill the little goose that lays the golden egg,' Discard the sulphur pit; don't kill your bees, I beg, But drive them, and you will get pure honey; save the bees, 'Tis very little trouble—and you'll pay your rent with ease.

W. O. MILLER.

#### BEE-TENT ENGAGEMENTS FOR 1884.

##### KENT BEE-KEEPERS' ASSOCIATION.

June 2. Bath and West of England Show at Maidenstone.

June 24. Rochester and Chatham Horticultural Society.

June 28. West Kent Horticultural Show at Chislehurst.

#### AMONGST THE SWISS BEE-KEEPERS.—XI.

Besides the private courses of lectures described in my last article, bee-keeping is encouraged and assisted by the Government, and instruction in agriculture, of which bee-keeping forms a branch, is given at the cost of the Government, and is free to every one residing in Switzerland, irrespective of nationality.

I have before me a pamphlet of forty pages, the Syllabus of Instruction in Agriculture for the Canton Vaud: all the lectures to be given during the winter of 1883 and 1884 at Lausanne. There are eleven professors appointed, each taking a different branch. Lectures, varying from one to four hours a-week, from the beginning of November to the middle of March, are given on the following subjects, viz.: Agriculture in general, Swiss Agriculture, Rural Economy in Switzerland, Nature and Treatment of Soils, Farm-buildings, Bee-keeping, Arboriculture, Surveying and Measuring, Agricultural botany, Chemistry, Profit and Loss, Geology, Horticulture, Dairying, Livestock, Legislation, Machinery and Mechanics, Meteorology, Forestry, Vineyards, Zoology, Cattle Breeding, Management of Domestic Animals. As I said before, these courses of lectures are absolutely free to every one, and for those coming from a distance arrangements are made by which the pupils can board and lodge at a cost of from 60 to 65 francs a-month. Work begins at 8 in the morning and continues until 12, then from 2 to 5 in the afternoon, and from 7½ to 9 in the evening, so that the pupils have not much time to waste in amusements. Once a-week they are taken over some farm or apiary and are practically instructed. At the end of each course an examination is held, and certificates of proficiency are granted. This sort of instruction is also given in other cantons, so that it is evident that bee-keeping has its fair share of Government patronage here, and it is not its fault that every one is not a bee-keeper.

Besides the two principal societies mentioned there are fifty smaller societies in the different cantons; but these work quite independently of each other, and are not like our county societies. I think it would very much tend to the welfare of bee-keeping in Switzerland if they worked in more on the plan we do, and had societies in every canton affiliated to the central societies, all working on the same rules, and sending delegates to the quarterly meetings. Much more could be done by united effort than is at present done by independent action. The Government of the country is carried out satisfactorily on this principle of federation, then why should it not do equally well in bee-keeping? With us we have no means of ascertaining how many hives are kept in the country, but here a return has to be made to the Government, as these are classed with farm-stock. We in England have to make an annual return of all stock kept on a farm, but no question is asked about hives of bees. Thus, by the returns, we find that in Switzerland there are 177,825 hives kept, and taking these at 12s. each (an average price far too low), they represent a capital of 106,695*l.* We are also able to find out the number of hives kept in each canton, and the number in proportion to the population and area of each.

By the courtesy of the Verein Schweizer Bienenfreunde I am able to give two diagrams of Switzerland, showing the state of bee-keeping in the country. Fig. 1 shows the number of hives kept for each 1000 inhabitants. The letters represent the different cantons, which





Fig. 1.

are shaded in proportion to the number of hives in each canton. For instance, w. at the bottom of the plan, represents Canton Wallis, or Valais; and by referring

and 120 hives per 1000 inhabitants. Some of the cantons are more thickly populated than others; therefore Fig. 2 will also be interesting as showing the comparison

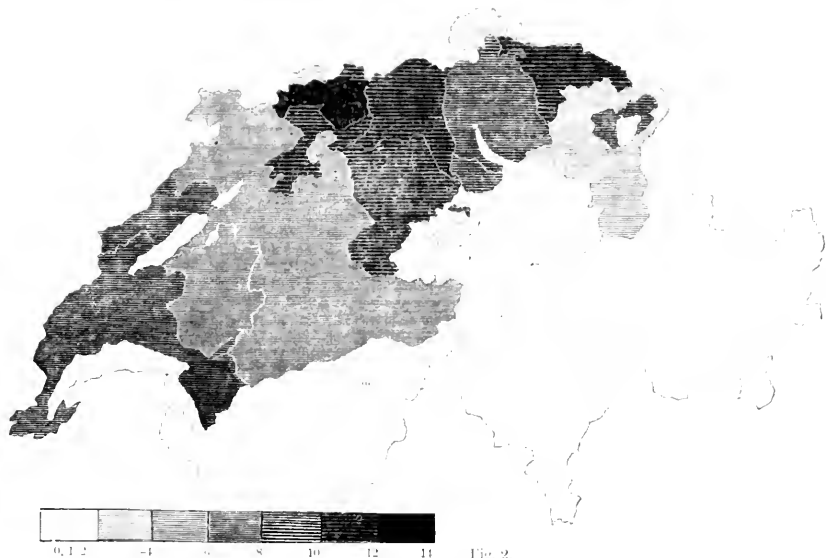

Fig. 2.

to the key at the bottom it will be seen that this canton is included in those containing upwards of twenty and less than forty hives per 1000 inhabitants. On the other hand, l. for Canton Lucerne, contains between 101

of the number of hives in proportion to cultivated land in the different cantons. By referring to the plan it will be seen that the mountainous cantons have the best number of hives. These are situated on the south

part of Switzerland, and have not more than 2 hives per square kilometre. The Canton Bern, however, which has also a great many mountains, rises to 6 per square kilometre; whilst Bâle has 14.

The following is the number of hives kept in each canton, viz.:—

1. Bern	39,226	stocks = 220.6% of the total number.
2. Vaud	23,067	" 129.7 "
3. Lucern	16,097	" 90.5 "
4. Zurich	15,418	" 86.7 "
5. Aargau	14,629	" 82.3 "
6. Thurgau	9,290	" 52.2 "
7. St. Gallen	9,158	" 51.5 "
8. Freiburg	8,490	" 47.7 "
9. Soleure	7,254	" 40.8 "
10. Grisons	5,915	" 33.3 "
11. Bâle	5,152	" 29.0 "
12. Neuchâtel	4,723	" 26.6 "
13. Valais	3,748	" 21.1 "
14. Tessin	3,342	" 18.8 "
15. Appenzell (outer Rhodes)	2,206	" 12.4 "
16. Schwyz	2,015	" 11.3 "
17. Zug	1,857	" 10.4 "
18. Geneva	1,821	" 10.2 "
19. Schaffhausen	1,427	" 8.0 "
20. Glarus	814	" 4.6 "
21. Oberwalden	622	" 3.5 "
22. Niederwalden	472	" 2.7 "
23. Appenzell (inner Rhodes)	471	" 2.6 "
24. Uri	382	" 2.2 "
25. Bâle town	228	" 1.3 "
Total	177,825	

Could our British Government be induced to take an interest in bee-keeping, and recognise it as a staple industry, it would do a great deal towards furthering what the different Bee-keepers' Associations have in view, viz., the improvement of the agricultural classes.—THOMAS W. COWAN.

## Echoes from the Hives.

*Shirley, near Birmingham.*—After the cold north-east winds which have prevailed so long, our little favourites are filling the hives very rapidly, and generally are in good order, although some few have died in the winter. We have now the advantage of the county expert, a very energetic person and just suited for the work.—C. B.

*Sheffield, May 9th.*—The weather this spring has been very bad for bees—cold, wet, and dull; gooseberries, plums, pears, and cherries have all gone and no honey or pollen from them, though they were loaded with bloom; apples and king sycamores are still to come, which are very promising.—JOHN HEWITT.

*North Leicestershire.*—From the 24th of April up to 8th inst., cold windy weather has been almost continuously prevalent. Many stocks have retrograded, but few at present require additional accommodation. Regular feeding has been necessary, for although supplies are still abundant on the fruit-trees, the bees cannot get at them. May swarms appear now to be out of the question, so serious has been the destruction of bees by the winds.—E. B.

*North Wilts, May 6th.*—The month of April was, I think, decidedly unfavourable to the bees, owing to the prevalence of strong easterly winds. When tempted out-of-doors by the sunshine many of the bees became chilled by the keen wind, and fell to the ground where they died. Great numbers of the pollen-gatherers were lost in this way. Rain fell on thirteen days, the total fall for the month being a little over an inch and a half, or, to be precise, 1 $\frac{1}{4}$ . I have been feeding during the

whole of the month and find that the bees have largely increased in numbers. Where feeding has not been resorted to bee-keepers have lost their stocks, or, if it has not quite come to this, breeding has been stopped, and the hives will be found in a backward state. A friend of mine in another part of this county, writing to me less than a week ago, said, 'This has been the most fatal season about here. Breeding having stopped in July, and there not having been two "bee days" together yet this year has played sad havoc.' Three days ago I found a drone Ligurian outside the hive chilled, and nearly dead. It was the first I had seen this year. To-day has been bright, and in places sheltered from the wind quite warm. Drones were flying from two of my stocks, a Ligurian and a black stock. We escaped the thunderstorm of yesterday, or at any rate the worst of it. The pear-trees are in full bloom, and the apples just coming out, so I hope that fine and warm weather will enable the bees to be out and gather a harvest from them.—H. B.

*South Derbyshire.*—The weather during the first half of April was warm, and the bees were very busy on the damsons, plums, pears, and gooseberries, and gathering pollen from the gilliflower and willow in abundance. The last half of the month was cold, and the wind east. A few bees were out during this period, with the thermometer at 40°. Although the wind has gone to the west since May came in, the air is very chilly. Yesterday I noticed a few drones lying in front of two of my hives.—T. W. J.

*Fairford, Gloucester, May 9th.*—The weather to-day is very fine, therm. 67° in the shade, but it has been very unfavourable the last two or three weeks: frost at night, and strong winds and rain by day, which have been very trying for the bees. Some stocks have been lost that had stood very well through the winter, and several others would have died if they had not been fed. Mine are all in fair state, but not like swarming.—JOSEPH COOK.

## Queries and Replies.

QUERY NO. 769.—(A. HULSE.)—*Spring and Autumn Feeding.*—In reply to Query No. 767 in *Bee Journal* of 1st inst., it is said that 'Syrup for use in spring may be simply a solution of sugar not boiled at all.' Is this as good for the bees as when it is boiled? and why cannot it be used in this way for autumn and winter feeding? And what are the advantages of boiling sugar? Is lump sugar to be preferred to any other?—A. The reason for boiling food for autumn feeding is that without doing so the water will not take up sufficient sugar; in other words, you would introduce much unnecessary water to the hive, and give the bees the labour of evaporating it. For spring feeding, when an excess of water is actually required, a solution of sugar not boiled is just as good as if boiled. Refined Crystallised Sugar is to be preferred to raw. (See Query No. 770, No. 2.)

QUERY NO. 770.—(W. E. M.)—1. *Casting out Larvæ.*—I have a strong hive of eleven frames, formed by the union of two, one of which had lost its queen. A few days ago I observed that white drones were being turned out; this was followed by a few fully formed drones. The weather was, and is, too cold to admit of my examining the hive, and I cannot see by simply lifting quilts whether there is a supply of food. To be on the safe side I began feeding with syrup. Although the stock is a very strong one, I find the bottle of syrup only partly taken, the quantity put into the bottle not exceeding two ounces. Does this show that there is food still stored in the hive? and if so, why should the drone brood have been thrown out? Can it be that there was an intention of swarming, and that this was given up in

consequence of the prevailing cold:—A. The cold weather has probably caused the cluster of bees to contract so much that it was unable to cover all the brood; hence the casting out of the larvae and pupae, or nymphs. Want of food may, however, be a partial cause, especially if the population of the hive is large. The syrup in the bottle may have granulated, and so from this, or other cause, the bees are unable to get at the food. Use a feeder from which the bees can feed rapidly. We suspect it is a case of starvation. No doubt the bees were preparing for swarming, but failure of food and cold weather has checked the propensity.—*2. Feeding.*—In last number of *B. B. Journal* you say that cane and not grape sugar should be used for bee syrup, but that nearly all the loaf sugar sold is made from beetroot, and contains a large proportion of grape sugar. What sugar, then, do you recommend for making syrup?—A. That sugar is best for feeding bees which possesses the greatest saccharine properties, and is least chemically treated. The pure West India sugars, the Muscovado, Porto Rico, or other, are the sweetest, but complaint is made that a sediment is left from those which clogs the small holes of the feeder. The Refined Crystallised Sugar contains almost a large percentage of the saccharine principle, and when boiled is perfectly clear. Loaf sugar is chiefly made from beetroot, and has a decided tendency to granulate.

QUERY NO. 771.—TYRO.—A. You do not say whether your bees are in frame hives or in skeps; whether your wish is to increase the number of colonies or to obtain surplus honey-comb or extracted; but at this period of the year we submit the following advice for your guidance:—The best time for transferring in spring will be about the twenty-first day after the bees have swarmed. In the meantime, if increase of stocks is a desideratum, (say) twelve new frame-hives should be provided, and the frames in them should be fitted with comb-foundation, to be in readiness for the six swarms and the six casts (or one swarm) that may be expected to issue from (say) six stocks. In stocking the hives with the swarms, which may reasonably be expected to be of average size, they should be confined to (say) four frames of foundation each, and the casts to not more than three, the rear of the hives being shut off by moveable dummies. After about forty-eight hours an additional frame of foundation should be given in each case, and a similar addition should be made every day or two, as the bees show ability to convert them into comb until the brood-nest is as large as the bees are able to occupy. Then additional frames should be placed between those that have their foundation worked out; and as soon as the bees show unwillingness to work out the foundation, the outside frames, the combs of which will probably not be quite completed, should be placed in a more central position where they will be finished, and the brood-nest will then be complete for the time being. On the twenty-first day after the first swarms issued there will be no brood left in the hives, except probably that of useless drones, and then the combs from the skeps can be transferred to other frame-hives with safety. In doing this the bees should first be driven from their hives into other skeps which should be placed on the stands to which the bees in them belong. The combs should be carefully examined, and if eggs be found in the cells they will indicate that the young queens left in the hives respectively after the issue of the casts have become fertile. If no eggs are found, the fact should be recorded, and the hive watched that it may be re-queened, should the continued absence of eggs indicate queenlessness. In transferring it will be better to fill a few of the frames with worker comb (rejecting the drone-comb) in preference to partly filling a number of them, and frames of foundation may be put between them alternately. When ready the frame-hives should be put in place of the skeps containing the driven bees, which latter should be put into

them as if they were natural swarms. To do this, the dummies in rear of the combs should be raised about an inch from the floor of the hives, and the bees shaken into the space in rear of them. The whole operation should be timed so that the driving should take place in the evening that there may be no inducement to robbing, or desertion by the bees themselves. If so desired, and the policy of the proceeding will depend on the weather in a great measure, the whole business may be forced at an earlier date than that of natural swarming. When the stocks are sufficiently strong a swarm may be driven from one of the hives (the most forward, of course) and placed on the stand from which it was taken, the sloping set on another stand with its entrance nearly closed, so that only two bees can pass, where it should be left for eight days, during which time a number of queen-cells will be raised in it. On the seventh day the remaining skeps may be 'driven,' and the swarms placed as above directed, and on the next day the combs and remaining bees may be transferred to frame-hives. In this latter case the frames of comb must be put side-by-side in the new hives because of the sparseness of bees, due to the swarms having been so lately taken away from them, and for the economisation of heat. The day after the swarms have been made, or two days at the farthest, which will be the eighth or ninth day, as the case may be, after the first skep was driven, it should be driven again, and the comb and bees from it transferred to a frame-hive; and while the transfer is going on queen-cells should be cut from the combs, and put one each into the other newly transferred hives—a series of operations that will cause queens to be brought into life at least a week earlier than otherwise would be the case. The queen-cells need only sit point downwards between two of the top bars of the central frames, care being taken not to damage them in any way. If put in through the feed-hole, and the thick ends of the cells should project above the quilt, protection should be given to them to prevent crushing, for which purpose a feeding-stage, hollow side down, will be admirable, and if a bottle of food be placed on every stage there will be very little likelihood of the queen-cells being neglected, as the food in the bottle will cause many bees to surround them.

The arrangement of sections in rear of brood-nest is quite a question of taste and convenience. They will do equally well in section frames, or in crates for the rear, either of which will be found a convenience; but if economy be a consideration they will do quite as well if set upon the floor-board. To do this effectually, a temporary dummy should be provided to fit in the rear of the brood-nest, and in it some slit should be cut to correspond with the inner top and bottom edges of the sections as shown in cut, and if the sections be placed against this

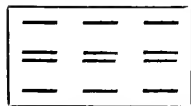

and corresponding pieces of very thin wood be put outside every set of six, a 'pile' may be formed that can be added to or diminished at pleasure, and than which nothing can be more simple or effective. The thin dividers need not touch the hive-walls closely, so that precision in cutting them is not an essential to success, but the dividing dummy should fit closely (to prevent propping) and should be fixed, so that the pressure from behind the sections, necessary to make them touch closely, may not cause the dummy to press against the frame of comb in front of it.

In fixing foundation the simplest and best way is to split the frames along the centre as in the cut, and to cut one side through, as shown, then by pulling the cut side open the foundation can be readily put into the gap,

when a couple of pins driven through the top bar will hold all properly together. In nailing the bar some one-



inch French pins will answer well, and to prevent possibility of their giving they should be driven diagonally, small holes having first been made with a fine bradawl.

QUERY NO. 772.—(S. L. B.)—*Spreading the Brood.*—In Mr. Cowan's book on bee-keeping, there is a passage in which he insists much on the benefits of 'Spreading the Brood.' But his practical directions on the subject are very vague; and he does not explain the *rationale* of his precept at all.—1. The directions for spreading the brood and the reasons for it are clearly given in Cowan's *British Bee-keepers' Guide Book*. On p. 95, under 'Spring Feeding' it is stated that 'rapid development may be encouraged in spring, if honey is plentiful in the hive, by uncapping some of the sealed cells every few days with a knife, and allowing the bees to help themselves as they require it.' This is done before regular spring feeding is commenced so as to stimulate the queen to commence breeding, and also to give room in the combs for brooding. Regular spring feeding should not commence in any other way as long as there are stores in the hive. At p. 99, full instructions are given for spreading the brood, and the object as stated is to have the stocks strong. The brood-nest is contracted by division-boards and the bees crowded on as many frames only as they can cover. The queen having commenced breeding by the stimulation described above as soon as there is brood on the frames, the frame containing the least brood has all the honey-cells uncapped and is placed in the centre between the other two, the bees remove the honey from the cells, store it elsewhere and give the queen room to lay the eggs. You were quite right in uncapping all the cells as the hive being crowded with bees they would soon transfer the honey to another part of the hive. The labour in doing this stimulates them to activity, which is the object desired. It is quite sufficient after this to examine the hive once a-week as directed. Brood will appear on the combs on either side of the three which have already been moved, and those containing the least brood will be uncapped and placed between the others and the same operation repeated every week until all the frames between the division-boards contain brood, then, and not till then, the division-boards can be moved and an empty frame inserted in the centre of the hive. No food will be required as long as any exists in the frames containing brood; but as soon as this runs short gentle feeding must be resorted to. Care must be taken to keep the space containing the brood between the division-boards crowded with bees. Read carefully again 'Spreading the Brood' on p. 99, and also the 'Caution' to be taken with regard to it.

#### NOTICES TO CORRESPONDENTS & INQUIRERS.

II. F.—*Receipts for Honey.*—Earthenware or glass are no doubt the best materials for honey-vessels, but tin does not injure it if kept clean. You may obtain earthenware or glass barrels with taps of wood, glass, or earthenware, of such houses who supply publicans' bar fittings. The name of Paine, White Horse Street, Stepney, London, occurs to us as being likely. Grocers' tea-cans with valves can be had of Gilbert & Co., St. John's Street, Clerkenwell, London, or of Parnell & Co., Wine Street, Bristol. We need hardly remind you that either of these arrangements is only suitable for unset honey.

MRS. BERNES.—*Preventing Swarming.*—If you return the swarm, preserve the old queen and destroy all queen-cells in the stock; but remember that your

queen will next year be past her prime. To avoid this it would be as well to allow one of the queen-cells to hatch out in a nucleus hive, and when fertilised and laying exchange her for the old one. You will thus get your stock headed by a young queen, and yet lose no time while she is being raised, &c. You may prevent swarming by giving plenty of room and destroying queen-cells as soon as found.

W. C.—*Dysentery, &c.*—Mr. Neighbour's advice to you was quite correct; but from your own description we do not think your bees are afflicted with that terrible disease called 'foul-brood.' The 'yellow spots' of which you speak were symptoms of dysentery, not foul-brood. Your losses probably arose from young queens failing to mate, dysentery, &c. Can you not obtain a visit from an expert before adopting strong measures? When the disease is once known the remedy is simple. We should certainly think that you run no risk in preserving your swarms. It is very easy to over-manipulate, *i.e.*, to meddle and muddle too much; and from your own description we are inclined to think that you have used too much salicylic acid, and created too great a disturbance in your hives. It is impossible for bees to do well if they are always being pulled about.

SUBSCRIBER, *Hendon Mersey.*—*Pettigrew's Hives.*—

(1.) Pettigrew's hives are so large that it is by no means certain that your hive will cast a swarm. (2.) *Prospects of Honey.*—Probably, the season being good, your bees would have more than enough left for their winter's supply, independently of the supers. (3.) *Time for Supers.*—When the hives are full of bees, and when the latter show signs of overcrowding. So much depends on locality, forage, &c., that it is impossible, without knowing the circumstances, to give a categorical answer. Most likely the end of this month.

S. G.—*Time for Re-queening.*—Your idea is quite impracticable. Queens are rarely heard to 'pipe.' Make artificial swarms, or allow your bees to swarm naturally. This 'piping' or 'trumpeting' of queens, as you term it, if heard at all, is so usually before the issuing of the second or third swarms.

W. H.—To answer all your questions would require us to write a book. We advise you to read carefully *Modern Bee-keeping* and Mr. Cowan's *Guide Book*. Meanwhile we gladly give advice on a few salient points. 1. *Feeding.*—Feed at the top of the hive, if requisite, with bottle-feeder. 2. *Position of Hives.*—You cannot improve the position of the hives. 3. *Expediting Swarming.*—No. You will do well to take artificial swarms when the time for it arrives. 4. *Preventing Bees going out on chilly Days.*—By no means. 5. *Preparation of Hives.*—Nothing except a thorough cleansing. One good swarm is sufficient for one hive. 6. *Number of Frames.*—This depends on the size of the swarm; if 4 lbs. in weight, give all the frames nearly filled with foundation. 7. *Bar-frames.*—The bar-frame is decidedly the best system. Collateral hives are rarely used now. 8. *Covering of Frames.*—Nothing. Let the super cover all frames. 9. *Expectation of Honey.*—Yes, if the season prove a good one. 10. *Transferring from Skeps.*—Three weeks after the swarms leave the hives, the old stocks may be transferred to frame-hives. Your remaining three questions would require a long essay. You may obtain all the information from the books named above.

Q. Q. Q.—1. *Deal Queen.*—Without any details as to the history of your queen, and from the state of her ovary, we are inclined to say that she was getting aged, and had been deposited by the bees. Had you put into the hive a comb containing eggs, a queen-cell would have been raised. But it would save time

by the purchase of a fertile queen, who may be procured of any respectable dealer. The insects sucking the vitals of chilled bees were *Acrida*, or mites, which most probably were introduced into the hives in the food which had been given them. (See reply to 'A Tyrore Man'.) 2. *Glass in Hives*.—We object to glass in hives. The water was caused by condensation on the bees not being sufficiently numerous to warm the hive into the corners. If the glass be not perfectly darkened, the bees, endeavouring to find an egress in that direction, die in great numbers. 3. *Drones*.—After drones have been hatched five days, they will fly out to fertilise a queen. 4. *Working out Combs*.—If the bees are confined to a smaller number of frames, they will extend the comb to the frame ends. 5. *Position of Sections*.—It would be better to put your sections at the back of the brood-nest. 6. *Dysenteric Sympoms*.—The feces on the outside of the hive are undoubtedly a sign of the bees not being in a healthy state; but if the inside is not soiled no mischief will accrue. After a long confinement this is frequently seen, but a purifying flight restores them to health. Keep the entrances clear, and add a little salicylic acid to the syrup until settled fine weather. 7. *Spreading Brood*.—You will find your case met by Reply to Query 772. 8. *Width of Entrances*.—These may now be five inches. 9. *Removing Supers*.—Blow a little smoke into the super to cause some of the bees to leave, then prise it up and carry it away. If the bees are troublesome employ smoke during the whole of the operation, but generally it is not much required. 10. *Queen's Foundation*.

We received recently from America a sample of this foundation, which was everything that could be desired. Care must be exercised that the wire employed should not be injurious to the brood.

**STUDENT**.—1. *Deceptive Honey-comb*. It is very unusual to find empty cells sealed over. If the combs had been out of the hives for some time possibly the cells had been punctured and the honey removed by ants or other insects. 2. *Double sealing of Sections* is the thickening of the capping if left on the hive too long. The dome-shaped cappings of drone-cells have generally supports built having their centres at the junctions of three of the cells. 3. *Sections not filed*.—It is difficult to get the lower edges filled quite into the corners. 4. *Cavariats*. Your greenhouse door being left open and being near the hives allowed your bees to find their way out after visiting these flowers, but as a rule greenhouses are dangerous bee-traps. The bees got in and fly to the glass, against which they worry until they fall exhausted. 5. *Section Cases*.—The fact of varieties of arrangements being adopted by hive-makers shows that opinions vary as to the best method. In those where the sections touch one another there is probably greater economy of heat, but when they are separated, it gives finger space for removal. There is no box to fit outside, but it is as well to wrap paper or similar material round to confine the heat. Bees will not enter cold and draughty supers. 6. *Suing Honey and Sections*. You would find it better, if you want both, to devote some hives to one system and some to the other. 7. *Strength of Hives*.—A stock covering only four Langstroth frames in the middle of May would be considered rather weak. 8. *Feeding*.—Yes, the presence of barley-sugar, combined with the mildness of the season, no doubt induced breeding. Perhaps your battles are not over the cluster, and so in cold weather the bees cannot extend themselves to reach them. 9. *Introduction of Queen*.—Between March 21st and now she would, being a good one, have had plenty of time to repopulate the hive.

**EISOM**. 1. *Dead Grubs*.—The immature bees thrown out were probably chilled when you transferred in the cold weather we lately had, which was totally unsuit-

able for such an operation. 2. *Crowded Hives*.—Yes, you may put on a super with fair probability of its being filled. 3. *Foundation not worked out*.—You have been too eager. In the first place, as stated above, the weather was too cold; secondly, you ought to have given the bees all their combs except the extreme outside ones; thirdly, until the population had so increased as to well cover the combs already in the hive you only checked them by inserting sheets of foundation which they could not cover to work out, remove one or both for the present.

**M. HULL**.—*Age of Queen*.—There is no certain mark by which the age of the queen is ascertained. There is greater activity and sprightliness in motion in young queens than old. The age must be deduced from facts. The old queen always leads off the swarm; and therefore by keeping a register of the first and after swarms bee-keepers become aware of the ages of their queens. Mr. Cowan is about to publish a *Bee-keeper's Notebook*, which will simplify and methodise the various events which occur in the history of stocks.

**F. W. JONES**.—1. *Swallows*.—Swallows do sometimes eat bees. 2. Bees crowded on six and seven frames may be considered to constitute a fairly strong stock.

**W. E. BEST**.—*Drum-brooder*.—It would be best to unite the remainder of the bees to another hive. It is a disputed question amongst bee-keepers whether the drones from a drone-breeding queen are capable of fertilising a young queen. Evidently some accident must have happened to the queen about autumn which affected her ovary.

**A TYRORE MAN**.—The insects forwarded are not *Braule cress*, which are sometimes found infesting bees, but a species of *Acarida* or mites, frequently to be seen in large numbers on humble bees. Probably they may have been introduced into your hive in the pea-flour or the sugar you may have been feeding the bees with.

**W. C.**—*Ants in Hives*.—Ants cluster in hives for the sake of warmth. There is a difference of opinion as to whether they are injurious to bees or not. A case mentioned by a correspondent in Vol. XI. p. 153, would make it appear that they are sometimes the cause of the destruction of bees. But many bee-keepers, Professor Cook amongst the number, say that they do not molest or are molested by bees. Paraffin oil sprinkled around a hive will prevent their intrusion; or draw a line round each leg with pitch dissolved in linseed oil.

**J. S. WOOD**.—We would suggest that you should adhere to the recognised method of making an artificial swarm. By your plan we fear that the bees would fly back to the hive in the old position, leaving too small a quantity of bees to rear the brood in the hive.

**R. BRIDGER CAMPBELL**.—*Cypha Bees*. The article on these bees has not come to hand. If re-written, please forward direct to us.

**C. N. WHITE**.—*Burrowing Bees*. The bees are burrowing bees; specific name *Audrena Primverana*.

**CHARLES WOOD**.—1. *Spreading Brood*. If your stock with only four frames is strong enough to have brood on all, you may when spreading it add another frame, and again the second time, and so on as the number of bees increase. See Reply to Query No. 772. 2. *Examining Hives*.—Supposing the hive to be properly constructed, with wide shoulders to the frames, with the combs across the entrance, and with a dummy in front of them forming an ante-chamber, we think our correspondent rather over-stated the case when he spoke of a week being occupied in raising the temperature again. The mere fact of disturbance and excitement causes a considerable rise in the temperature of the hive, and, unless the exposure of the combs was very prolonged, the normal temperature would soon be regained, and hot water would be unnecessary.

M.—*Artificial Swarming*.—It is one of the essentials of artificial swarming, that you should know after you have driven the bees in which live the queen is. There should be no blind chance in a matter of such importance. 2. *Supering*.—The greater number of worker bees you have at the time of supering, the clearer will be your prospects of obtaining honey when the season arrives. With a strong working stock, it does not much matter whether the supers are placed above, behind, or inside the hive.

B. FLATMAN.—1. *Ligurians and Red Clover*.—Ligurians and Syrians are said to be able to reach the nectaries of red clover. 2. *Tarring Skeps*.—It will do no harm to tar or paint a skep, and will tend to preserve it, but as it will render it impervious to air you had better bore a hole in the crown, closed with some loose material. 3. *Propolisation*.—Zinc or other metal does not prevent propolisation, but, as propolis adheres less strongly to metal than to wood, less jar is caused in separating it. 4. *Bees in Exhibition*.—We do not know whether Mr. Marriott's bees are at present exhibited at the Crystal Palace, but the British Beekeepers' Association have a large and interesting exhibit of hives, bees, and all kinds of appliances, at the International Health Exhibition, South Kensington. 5. *Salicylic Acid and Wax*.—It would not do at all. To be of any service the acid must be received by the bees with their food, or it must be applied directly to them. 6. *Bligh Competition*.—Your suggestion is too late for this year, it might be entertained on a future occasion.

G. S.—'The blue sediment' is the residuum of the colouring matter (indigo) which is used in the manufacture of loaf sugar. Our preferences, for reasons stated in reply to No. 770, tend towards the employment of Refined Crystallised sugar for syrup.

**SUPERIOR BEE VEILS**, Wire Gauze Fronts. 1s. each, three for 2s. 9d., post free. Address Wm. CRISP, Halstead. 2025

**COMB FOUNDATION MILLS** (Machine made in Brass) any length, from 5s. per inch.

COMB FOUNDATION, free by parcels post, 2s. 6d. per lb. HONEY EXTRACTORS, with all the latest improvements. Price, from 25s. each. SMOKERS, 2s. 6d. each. Address A. GODMAN, St. Stephen's, St. Albans, Herts. 2167

Herefordshire Bee-keepers' Association.

**SHOW OF HIVES AND BEE-FURNITURE**

IN CONJUNCTION WITH

THE HEREFORDSHIRE AGRICULTURAL SOCIETY, LEDEBURY, June 24th, 25th, and 26th.

Schedule of Prizes (including 40s. and 25s. for Best Collection, and two Classes for Honey) on application.

Entries close May 24th.

**MICROSCOPIC SHOW, ILLUSTRATING BEE-LIFE.**

(In order to make this department as complete as possible, the loan of Microscopic Slides for exhibition will be gladly accepted.)

**EXHIBITION OF HIVE-MAKING,**

both Bar-frame and Skeps, by workmen on the ground. MANIPULATIONS AND LECTURES IN THE BEE-TENT.

**BEE-KEEPERS' CONVENTION**

(For the discussion of Questions in Practical Bee-keeping).

On THURSDAY, June 26th, at 11.30 a.m., to which all Bee-keepers are cordially invited.

Price Lists and further particulars on application to the Hon. Secretary, ALFRED WATKINS, Wilcote, Hereford. (66)

**'THE BEE-FARM,' Braintree, Essex.**

Under superintendence of R. W. DAVIES.

**COMB FOUNDATION**, made from Root's Machine. Thick, 2s. to 2s. 6d.; Thin, 2s. 6d. to 3s. per lb. FEEDERS, slow or rapid, 2s. SECTIONS, V cut, per 100 1 lb., 4s. CRATE, and 21 Sections ready for use, 2s. DOUBLEWALL GROOVED HIVE on Legs, Nine Standard Frames with Metal Ends, Dummy, Section Holder, can be placed either way, Crate, Tin Separators, Glass 21 Sections, Quilts, Double Sloping Roof. Price 14s.; painted, 15s.

**BEE HIVES and APPLIANCES**

Of the best quality, at the lowest possible price, to be obtained from

**JOHN LEAKE, JUN.**  
BEACON STREET, LICHFIELD.

COTTAGERS' HIVE, made of 1-inch best Pine, planed outside, contains 9 Standard Frames and Dummy, resting on Tin Runners, suitable for Bee-Shed. Price 4s.

ABBOTT'S HONEY EXTRACTOR, best make, 9s. 6d.

BINGHAM SMOKER, neatly and strongly made, 3s. 6d.

Other Appliances at an equally low rate. 5 per cent. discount off all Orders up to April 1st.

Send Card for PRICE LIST to

J. LEAKE, Jun., Beacon Street, Lichfield. 1973

**E. M. HART & CO.,**

The LONGSTOCK HIVE Manufactory, STOCKBRIDGE, HANTS.

**SPECIALITIES:**

HIVES, complete, from 6s. SECTIONS, V-cut, in 6 sizes. FOUNDATION, Flat, or natural based.

CLARK'S COLD-BLAST SMOKER. 'Far and away the best Smoker.' 3s., post free.

HART'S SIMPLEX FEEDERS. 'The easiest and best to manage.' 1s. 6d. each, 15s. dozen.

THE 'SWANMORE' SECTION CRATE. 'The most perfect Crate made.' (60)

The Trade supplied. Price List on application.

Do not order your Hives and Appliances until you have seen E. C. WALTON'S CATALOGUE for 1884, consisting of 36 pages, fully illustrated.

Send free for 1d. Stamp on receipt of Address.

**E. C. WALTON,**

NORTH MUSKHAM, NEWARK.

CATALOGUES FREE.

Simmins' Hives, Crates, & Sections.

'FORTRESS HIVES.'

Association 'Standard' Bar-frames, 1s. doz.

J. H. HOWARD, Holme Apiary, PETERBORO'. 1887

The only Weekly Bee Paper in the World.

**THE AMERICAN BEE JOURNAL**

Established in 1861.

Edited and published by THOMAS G. NEWMAN, at 925 West Madison Street, Chicago, Illinois, U.S.A., and will be sent to European Subscribers at 10s. 6d. per annum for the Weekly, or 5s. for the Monthly, including Postage. The money may be sent by International Postal Money Orders on Chicago. London Agents: Messrs. Geo. Newbourn & Sons, 149 Regent Street, W.

# THE BRITISH BEE JOURNAL

Communications to be addressed to: Secy.

PRINTED OFFICE, Tower Street, St. Martin's Lane, W.C.

[No. 147. VOL. XII.]

JUNE 1, 1884.

[PUBLISHED FORTNIGHTLY.]

## Editorial, Notices, &c.

### THE VOLUME OF COLLECTED REPORTS.

Until the Central Association can afford to give greater publicity to its most useful volume, we can only offer the bee-keeping public in its 217 entries contents by extracting from it what seems to us to be of most general interest, and presenting it to our readers in the most condensed form possible.

We will note, in the first place, that thirty Affiliated Associations have this year forwarded their reports and balance sheets to the Secretary of the Central Association in time for publication. The defaulting counties are Lincolnshire (which from the complaints of our correspondents appears to be in an unsatisfactory condition generally), Lancashire, and Bedfordshire. We hope that these omissions will be repaired another year, so as to make the volume as *complete* as possible, and that we shall be able to present our readers with an article on the reports of at least forty Affiliated Associations. The recent decision as to the disposal of the *Bees' Testament Fund* will no doubt have a good effect in making County Associations more ready to comply with the conditions of affiliation.

Straws show which way the wind blows, and the little value at present attached by County Associations to the privilege of sending representatives to the Quarterly Conferences, is evidenced by the fact that only five Associations, viz., Cheshire, Devonshire, Essex, Hertfordshire, and Wilts, have published the names of such representatives in their lists of officers. This omission indicates that the importance of the Quarterly Conferences is not yet fully understood by the Associations generally, and that, from one reason or other, representatives have not been elected at their General Meetings at all, or if they have been, are held in very little honour. Before another volume is issued, we are in good hope that, by some amendment in the mode of Representation, the Quarterly Conferences may be made accessible to the representatives of the Associations most distant from London, and that all Associations may become sensible of what they may lose if they neglect to send representatives to the Conferences by some means or another. To finish our enumeration of omissions, we would remark that five counties have sent in no list of their

members, or the amount of their subscriptions. One county has sent a list of its members, but not the amount of their subscriptions. These details are all useful for statistical purposes, such as making a census of the full strength of the Central and Affiliated Associations, and ascertaining the amount of money annually expended in the advancement of bee-keeping. They cannot therefore be omitted without loss to the cause in hand. Such statistics will be indispensable if the Beekeepers' Associations are ever to be recognized and subsidised by the Government of this country. Some portions of the present volume, such as advertisements, for sale of publications, &c. (which, we should we think, be omitted in the future volumes), or the book will generally be fully and usefully, to be of general use.

To notice the new and pleasing features of this year's volume, we find that the advice given in the columns of this *Journal* and in some of the Papers read at the Quarterly Conversazioni has not been given in vain. First, as regards the appointment of County Experts. We find such appointments recorded in the reports from Berkshire, Devonshire, Dorsetshire, Essex, Hertfordshire, Hertfordshire, Kent, Surrey, Warwickshire, Wiltshire, and Wiltshire. Other Associations appear to have instituted experts' tours, but the names of these experts do not appear in the list of the officers of the Association, which seems to us to be an omission. No doubt, in the early stages of a County Association an expert *resident in the County* cannot always be found, and the services of Messrs. Baldwin and his *coffers* have to be resorted to. It is very desirable, however, that the county expert should be a *county* man, so as to ensure a *resident* authority upon bee-keeping, and a connecting link between the members and the committee of the County Association. In some reports, notably in those of Hampshire and Wilts, reference is made to the certificates and *chairs* of certificates which the county experts hold from the Central Association. We think this is a point which should not be overlooked by other counties in their reports.

We have next to notice with great satisfaction the adoption of the *district system* by so many Associations. In the reports of Cambridgeshire, Carmarthenshire, Derbyshire, Hampshire, Kent, Oxfordshire, Staffordshire, Surrey, and Wiltshire, we find the names of *district* secretaries recorded in the lists of the officers of the Association, with,

in some cases, the districts named over which they have the superintendence. In the Buckinghamshire report the names of the members belonging to each district are given. This, we think, is a very useful addition to the ordinary report, as showing at a glance in which districts the district secretaries work the hardest, and pointing out those weak spots in which the intervention of the county secretary, and some special effort to remedy the inefficiency of the district secretary, is most required. In the Hertfordshire report, though the list of district secretaries is given, we find a list of ladies and gentlemen who have undertaken to act as *local advisers* in different portions of that county. All this we regard as a great step in advance from the reports of the year 1882.

In some Reports, notably in that of Berkshire, we find mention made of a County Library of Bee-keeping literature—an institution which we cannot too highly commend to the notice of County Secretaries. In the Herefordshire Report attention is specially called to the conditions attached to the Medals and Certificates offered by the Central Association of County Shows, which is also well worth notice, there having been some uncertainty and confusion on this point in former years. One special feature of the Report from Herefordshire (that county of orchards, and the fountain-head of cider and perry, which the fruit-blossoms make so beautiful in the springtime) is the reference to Mr. Gladstone's speech at Hawarden on the 9th of January last, showing that fruit-growing is likely to become of greater importance in this kingdom, and that already 27,000 acres more of ground have in the last ten years been given to producing fruit. Alluding to this speech, the Secretary of the Herefordshire Association writes as follows: 'The Premier advocates strawberry-growing on a large scale. Only let fruit-growers remember that blossoms may be plentiful and yet fruit scarce, for in many instances the kindness of the bee in fertilising the blossom has to be depended upon. Bees must be therefore more extensively kept, and as a result, not *Jam* only, but *Honey*, gathered in the production of fruit, will be more frequently enjoyed at our daily meals.' As a commentary on this portion of the Herefordshire Report, we would call attention to the announcement made lately that Lord Sudeley, the President of the newly-formed Gloucestershire Association, has laid down 500 acres of ground for the production of fruit, and that he has established in his orchards an apiary of from 100 to 150 hives of bees for the purpose of fertilisation. We can only wish that the same '*local colouring*' which Mr. Alfred Watkins has thrown over the Herefordshire Report could be extended to the special features of other counties.

In conclusion, we would say that, although the details contained in the Reports of the Affiliated County Associations may have a more special interest for County Secretaries, who may all profit by each other's experiences, the general advance and progress in the spread of Bee culture manifest in this volume must command the attention of all thoughtful readers of this *Journal*: and when we

couple with this improvement in the organization for the production of honey, the increased demand for honey, such as that announced in our last number by Messrs. Huntley and Palmer, through the Secretary of the Berkshire Association, we cannot help feeling that we are on the eve of a *new departure* in the annals of our Associations, and that the dream (as it has been called) of a new national industry is not so very far from being realised.

#### EXPERT EXAMINATIONS.

First, Second, and Third-class Expert Certificates will be granted by the British Bee-keepers' Association to those only who are successful in passing examinations under the following scheme:—

##### *For Third-Class Certificates.*

An oral and practical examination (that is to say, an examination in which candidates will be examined by word of mouth, and will also be required to show their skill in driving, manipulating, &c.) will be held at the request of any secretary of a County Affiliated Association at a suitable centre named by him and approved by the Board of Examiners of the B. B. K. A. The Examiner or Examiners will be appointed by such Board. The candidates for Third-class certificates will not be required to give a lecture, or to answer questions in writing. One month's notice at least of the proposed examination should be given to the Secretary of the B. B. K. A. (The full term of notice will not be required where it is desired to hold an examination during the month of June in the present year.)

The railway and personal expenses of the Examiners, as well as all local expenses connected with the examination, must be paid by the County Association.

Annual County Shows are suggested as the most suitable opportunities for holding these examinations, when the judge or judges acting at such Shows may be appointed by the B. B. K. A. to act as Examiners.

These examinations will be considered as part of the privileges afforded by the B. B. K. A. to the County Affiliated Associations, provided that they have fulfilled the conditions of such affiliation.

##### *For Second-Class Certificates.*

An examination open to all holders of third-class certificates will be held annually on a day to be fixed by the Examining Board, and announced in the *B. B. Journal*, at various centres throughout the country.

A centre shall be any place approved by the Secretary of a County Association affiliated to the B. B. K. A., where a superintendent on the recommendation of the said Secretary is approved by the Board of Examiners. Such centre may be appointed where only one candidate presents himself for examination. This examination will be entirely by papers, which will be sent down by the Examining Board, and must be considered, together with the answers, as strictly private and confidential, and



must be returned to them immediately after the close of such examination.

The result of the examination will be communicated to the candidates through the County Secretaries, and a list of successful candidates will be published in the *B. B. Journal*.

#### For First-Class Certificates.

An examination, open to all holders of second-class certificates, will be held annually in London, or elsewhere, on a day to be announced in the *B. B. Journal*. Candidates will be required to give a lecture, either in public or before the Examiners only, on any subject connected with the theory or practice of bee-keeping that the Examiners may select. They will also be required to pass an oral, and, if the Examiners think fit, a written examination on the natural history of bees and the science of bee-keeping. Candidates must send in their names to the Secretary of the B. B. K. A. at least a week previous to the date of the examination.

Fees for the third-class examination to be arranged and received by the County Association. For second-class examinations a fee of 2s. 6d., and for first-class examinations of 5s., is to be paid by each candidate to the Secretary of the B. B. K. A.

The second-class examination will be held this year on Saturday, August 16th, at 2 p.m., and the first-class examination at the Bee Department of the International Health Exhibition, South Kensington, on Saturday, September 13th, at 11 a.m.

*Note.*—It is hoped that by this means third-class certificates of the B. B. K. A. will be attainable by many competent and practical men, who from their habits of life are unable to enter for a written examination. Those also who wish to obtain a second-class certificate of the B. B. K. A. will be able to do so without the expense, as hitherto, of going to London. It is clearly to be understood that these examinations are conducted by the Central Board of Examiners, and that the certificates granted will be those of the B. B. K. A., and not certificates of a local character.

The dates of the examinations have been, as far as possible, so fixed that a candidate will be able to pass the oral and practical examination and proceed at once, or very shortly, to the higher examinations for second and first-class certificates, if he wishes to do so.

#### THE PEEL TESTIMONIAL FUND.

By a reference to the report of the last meeting of the Committee of the B. B. K. A. it will be seen that the rules regulating the administration of this Fund have been formulated. Its success will now depend on the bee-keepers of the country. The biography of Mr. Peel, which has recently appeared in the pages of the *Bee Journal*, shows most clearly that it is his energy and perseverance and tact is due in a great measure the present advanced position of bee-keeping in the United Kingdom. From the day that Mr. Peel accepted the office of hon. secretary his chief concern has been the formation of County Associations, and his success lies in the fact that there are now upwards of forty Associations affiliated with the Central.

The proposed Fund is intended solely for the benefit of labourers and artisans, and will be an appropriate recognition of the services of Mr. Peel. The money subscribed will be invested, and the interest accruing therefrom will be expended in annual grants to County Associations. The manner in which the grants will be applied will be left to the County Associations, subject to the approval of the parent Society. The advantages the County Associations will derive from this Fund are at once apparent. There will be no fixed method determined upon for the administration of this Fund; each county, knowing its requirements, will have the power to make its own arrangements for the disposal of the amount allotted to it. Circulars setting forth the objects and origin of the Fund will be supplied to each County Secretary for distribution, and these circulars will be accompanied with a subscription form for the subscriber.

This Testimonial Fund will doubtless give a fresh impulse to bee-keeping, and be a great means of benefiting the labourer and artisan. As a recognition of the worth of Mr. Peel, and as a proof of the progress of the science of bee-keeping, it is to be hoped that the Fund will prove a great success, and that each County Secretary will labour earnestly to bring about this result.

#### USEFUL HINTS.

The weather all through May has been, with the exception of a very few days, all that bee-keepers could desire. Consequently, stocks which had become rather backward during the cold weather in April have recovered themselves and are now crowded with bees, and if not already swarmed are at the point of doing so. Now is the busy time for bee-keepers, and on the management of bees in June depends the success or failure for the season. In a short time the clover will be in blossom, and unless stocks are strong and ready to gather the honey the best part of the season will be gone.

**SWARMING.**—A swarm of bees in June is worth a silver spoon, but there are spoons and spoons and swarms and swarms. It depends upon the intelligence of the bee-keeper whether the spoon shall be a salt spoon or a soup ladle. Those who have attended to our 'Hints' for May will now have fertile queens in nuclei, or at any rate queen-cells, ready to give to their stocks after swarming. Do not attempt to swarm or divide unless the stock is full of bees and brood in all stages. When that is the case lose no time in performing the operation, especially if you desire to avoid the issue of a natural swarm, with all its attendant trouble of watching, following, and securing. The method of doing this both from skeps and bar-frame hives has been so often described that we must refer any beginner to some textbook such as *Modern Bee-keeping*. Be careful to leave enough bees in the parent hive to take care of the brood.

**SWARMS FROM BAR-FRAME HIVES.** Properly speaking the usual method of 'swarming' from these hives is 'dividing'; but if a swarm (*i.e.* bees without combs) is desired, many are puzzled how to do it, although they would be quite *au fait* at performing the operation with a skep. First find the queen, and secure her either in a cage or by placing the comb on which she is in a box temporarily; put a skep on a large board on the stand of the bar-frame hive to be swarmed from, removing the latter a little distance, then lift out the frames and brush or shake the bees off them on to the board. When one or

two frames are thus treated liberate the queen and let her run into the hive along with the bees; do not depopulate the stock too much. If ten frames are crowded with bees, those from four frames with the flying bees will make a large swarm. You may, however, if you want a very large swarm brush all the bees off and put the hive containing the combs and brood on the stand of a second strong stock, removing that to the place of the swarmed one (supposing the swarm is to be sent away), otherwise it must be put on the old stand and No. 2 on a fresh one. Be sure not to shake the bees from combs containing queen-cells in progress, or you will destroy the queens, rather brush them off.

**PACKING SWARMS.**—If in a skep, before putting them in, make a hole in the crown if none already exists, and cover it inside with a piece of perforated zinc, being careful it is fixed properly, so that if placed on a flat surface air can still enter. A rope-handle to carry by will secure, so far as anything can, care in lifting by porters, &c. The cheapest swarm-carrier is a lobster-box, price 4d. Instead of the lid, cover with canvas or cheesecloth by laths nailed all round, and put a few laths across to prevent it being torn. Direct it to travel on its side, so that the bees may cluster on the other side (then the top), not on the canvas. Be very careful no bees can escape, not only for your own sake, but to prevent any complaint on the part of the railway company or other carriers, which may lead to future refusal of bees altogether.

**RECEIVING A SWARM.**—If it has been confined for some time, leave it for an hour or two to settle down before opening, and give about half a pint of thin syrup, otherwise you may find the bees have digested the honey they took with them, and, being hungry, will also be pugnacious. After feeding they will be as harmless as if just swarmed.

**HIVING SWARMS IN BAR-FRAME HIVES.**—There are many ways of doing this, but the simplest is to remove some of the frames, cover those left with the quilt, and shoot the bees into the vacant space. They will soon draw up among the frames left. Any knots and clusters which do not seem inclined to join the main body may be driven by a jet of smoke, or scopped up with a card and thrown among the others. The division-board is then brought up to the frames, and the operation is complete. Always hive swarms in the evening; next day remove such frames as are not covered with bees. Of course, before hiving, the frames must be filled with foundation or, better still, with ready-built combs. The hive must stand perfectly level or the combs will not be built perpendicularly in the frames.

**NATURAL SWARMS.**—If by neglect to artificially swarm in time, or from choice, you allow the bees to swarm naturally, they must be first captured from where they cluster in a skep. If they have chosen an overhanging branch, not too high, hold the skep close up to them and give the branch a sharp jerk—a swing is not enough—and the bees will all fall in. If they have clustered on a limb too thick to jerk, or on the trunk of a tree, they may be driven up into the skep held over them by smoke, or brushed into it. A little consideration will show the best way: after securing them, or the greater part, if in an awkward position, watch whether the remainder are inclined to join those you have secured: if so, you have the queen; if, on the other hand, those in the hive leave and join the others, you have failed to secure her, and must try to do so. Having secured the swarm with the queen, place it on the stand of the hive in which you intend to keep it, shading it from the sun, and putting a stone under one edge of the skep to give

plenty of ventilation. In the evening turn the bees into their permanent hive.

**REARRANGING AN APIARY.**—When swarming, either natural or artificial, is going on a good opportunity is afforded for doing this. By putting the swarm on the stand of the old stock until the evening, removing the old stock to where you wish it to stand, and in the evening removing the swarm to where it is to stand, removal can be effected without loss. The flying bees having joined the swarm, will remain where placed, as is the nature of swarmed bees; while the young bees in the stock will mark their new position, and so not get lost; a few stragglers may return to the old stand, but not enough to be of consequence. If increase is not required, this plan of moving short distances may be adopted; and by putting the stock and swarm close together, they may be reunited after a few days. If the stock is left until a queen is raised and fertilised, the old one may be removed before uniting, and the stock is requeened without trouble.

**WEAK STOCKS.**—Any stocks which are still weak and do not seem to increase as others do are not worth troubling about, and should be united at once, or the queens, which are obviously of no good, may be destroyed, and the bees and combs utilised for nuclei for queen-raising, to avoid robbing good stocks for the purpose.

**COMMENCING BEE-KEEPING.**—Owing to the necessary ignorance of a beginner to judge the value of a stock offered to him and the danger of getting one which, although in the hands of an expert, might be made the most of, in the hands of a novice would lead to disappointment, it is as well to commence with a swarm, and, to ensure a good one, stipulate that it must weigh at least 4 lbs.—of course no one now-a-days will commence except on the modern system of bar-frame hives. Do not be tempted from motives of economy to buy an old hive, but get a new one from an old-established manufacturer; let it be what is called a 'Combination Hive,' in which the frames run across the entrance; the frames should be of standard size and furnished with wide shoulders; the roof should be deep enough to admit of a crate of sections or a feeding bottle, and the hive should also be furnished with two dividers and two section frames for the rear of the brood-nest. The frames must be furnished with foundation, but as this will very likely be broken down during transit if put in by the hive-maker, you must put it in yourself; you will find the slits in the top bars of the frames, being made with a circular saw, do not extend quite up to the side bars, and must be made to do so by passing a saw along. An easy way of fixing foundation is to be found in the *Journal* for August, 1883, p. 118.

**FIXING FOUNDATION IN SECTION BOXES.**—Take a piece of bees-wax and rub the surface where the fastening is to be made until it is coated, then lay on the sheet of foundation, and with a putty-knife dipped in honey pass over the edge of the foundation sufficiently hard to cause it to unite with the wax on the wood when the sheet is turned at right angles.

**SWARMS DESERTING.**—The fact of newly hived swarms deserting their hives, even repeatedly, and finally flying away to the woods, is a source of annoyance and loss. The hives, if not new, should be thoroughly cleansed and washed with salicylic acid solution before using; but the only certain remedy for these vagaries of the bees is to place the swarm on the stand of the colony from which it issues. The latter may be placed beside it with the entrance turned to one side at an angle of 90 degrees, and may be gradually brought round to face the same way as the swarm. If supered before swarming the super may be transferred to the swarm, also one or two of the brood-frames,—but no queen-cells—and the remaining frames closed up by division-boards. The swarm will work as vigorously as before, and the chance

of the supers being filled will be equally as certain as if swarming had taken place. The old colony will soon be headed by a young queen, and may be united to the swarm in the autumn if increase be not desired, the old queen being deposed if too aged to do work. This plan may be followed with skips as advantageously as with frame-lives, except that no transferring of brood can take place. If increase be desired the original stock should be removed to a greater distance from the swarm, but the plan works best where no increase in the number of colonies is desired. By this system the colonies become exceptionally strong, the natural propensity for swarming is gratified; the queens, from being reared in full colonies in the natural way are far superior to those raised in small nuclei, and much labour is saved. Worker-foundation should be supplied to the swarm. Generally speaking no after-warms will be given.

*The Journal.*—One of the first things to do in commencing bee-keeping is to get the *Journal* for the past two or three years and read it carefully; not to try any of the numerous untried suggestions which you may find, but to leave that until you have gained experience. Then in your difficulties which you are sure to meet with turn to its pages, especially to the *Queries and Replies*.

#### INTERNATIONAL HEALTH EXHIBITION: BEE DEPARTMENT.

In previous numbers of the *Journal* we have noted the pain-taking exertions of the sub-committee appointed by the B. B. K. A. to superintend this branch of their operations, and their strenuous endeavours to make the Bee Department a credit to the Association, and one of the attractions of this most interesting and instructive Exhibition. And now, looking at the number and nature of the exhibits and their representative character, we may state that great success has crowned their labours. They have succeeded in having the Bee Department located in a most accessible part of the building. Entering by the principal entrance in the Exhibition Road and passing onward down the South Gallery the visitor will, on the north side, observe the Small Corridor which is devoted to bees and the means which lead to their culture. The space allotted is forty-seven feet by thirty-five; and the manner it is contained and furnished reflects great credit on the Secretary, Mr. J. Huckle.

As we escape from the concourse of people over-surfing down the South Gallery, and as we find ourselves in this retired and quiet corner, its comparative calm and restfulness invite us to such musings. As we note the wall-garden bed with the diagrams published by the B. B. K. A., and the pictorial portions of the *Harvest-book* framed and hung around on every cognate vantage; the cases containing all the appliances of bee-culture, and the counters covered with hives, sections, crates, wax and honey extractors, and other articles, we look around in search of something besides and beyond these; we muse and ask how far and to what degree does this department of the Exhibition fulfil the special purpose of its promoters; what contribution does it give to the health and food of the nation? The main object of the bee-keeper is the production of honey, and his desire is that the public should have the disposition to take the honey produced. Efforts have been made by the B. B. K. A. by lectures and by pamphlets to prove the excellency of 'honey as food' and its virtues as beneficial to health. We, therefore, naturally turned our attention, in the first place, towards those articles of food in which honey might form an ingredient. But we must confess that we here met with a disappointment. Very few exhibitors

have apprehended this view of the intent of the Exhibition. The Chairman of the B. B. K. A., T. W. Cowan, Esq., who, though now residing at some distance from England, has not been unmindful of the claims made upon him. Mr. Cowan has evidently bestowed much pains and taken a vast amount of trouble to collect the various articles exhibited by him. His collection consists of various edibles sweetened with honey; these are cakes, biscuits, ginger-breads, and eight different kinds of bannons. Besides these there are two jars of artificial honey, such as is extensively sold in Switzerland, and liberally supplied in all the hotels. This honey consists principally of glucose, and it is desirable that the attention of the visitor should be directed to these imitations, so that he should be habituated to detect genuine from sham honey. The collection is the result of Mr. Cowan's visit to Switzerland, and bears evidence that whilst amongst the Swiss bee-keepers he has not been an unobscure spectator. The Swiss and other honeys, analysed by Mr. O. Holmer, hon. analyst of the B. B. K. A., will be read later; as also the Honey Drops, the latest manufacture of Messrs. Huntley and Palmer, may be seen and tasted. Passing from these, we look around in hope of discovering other English productions in the same line, but the search is fruitless. Where are the nectared sweets, the mead, the methueglin, the melliflora (which we had fondly hoped would have proved the coming drink), the honey-suckles, the honey-wine, the honey-vinoger, &c. &c.? Echo-answers, Where? We have hope, however, that some of these may yet be forthcoming. The Exhibition is yet in its infancy, it has many long months yet to run, the opportunity is still present to fill up these vacant places. May we not, with some expectancy, trust that some of our lady bee-keepers might make an effort to produce these articles so common in even the smallest countries of the Continent? There can be no doubt that in consequence of the exertions of the B. B. K. A. a great impulse has been given to the production of honey; and it is most desirable that means shall be adopted for the disposal of the same, and this can only be effected by the development of fresh outlets for its use. The Confectioner and the Bee-keeper must come into closer bonds of union with each other.

As at present the Exhibition is far from complete, and many of the hive-manufacturers have not yet forwarded their goods, it would be premature to notice in detail the various bee-appliances. We shall embrace a future opportunity for their description. The Exhibition will be open for many months, and we may look forward to an increased and continuous supply of honey. In the meantime we would mention among the exhibits of honey that of Messrs. Garratt and Morris from the St. Mary's Cray Apiary; these are in very neat, well-corked bottles. Close to their collection is a specimen of honey from Jamaica. Messrs. Neighbour have several sections of honey, which looked very tempting. We are all pleased to record the same of the honey shown by Mr. Thorn, of Ashwell, Herts. Mr. Geoffrey, of Grantham, exhibited some honey and wax; also samples of honey from the seasons of 1877, 1881, '82, and '83, which, though preserved for such a length of time, had refused to granulate. Mr. J. Gilbert of Stamford, Mr. Babbler, Mr. Overton, Three Bridges, Mr. R. Norman, Charley, Sussex, a cottager, and others, are also exhibitors of honey. Mr. Sells, of Ullington, exhibits a glass super of honey, weighing 20 lbs.; and Mr. J. M. Hooker, of Heathfield, Sevenoaks, a premier one of about 56 lbs. This last gentleman has several sections of honey on show; Mr. J. Taylor shows honey gathered by the bees from limes, clover, and heather. We were much pleased with some bees-wax exhibited by Mr. W. Soar.

There are three stocks of bees at work having flight-holes towards the Exhibition grounds. The bees are Carniolans and Ligurians, exhibited by Mr. Neighbour,

and a strong healthy stock of blacks belonging to Mr. Stubbin. These bees are a constant source of interest to the visitors. A most interesting series of lantern slides, photographed by Mr. Alfred Watkins, of Wilcroft, Hereford, is exhibited by Mr. A. G. Dawson of Macclesfield. These represent the physiology of the bee, and contrast the old mode of bee-keeping with that adopted at the present day. By the aid of these, a lecture on bee-keeping might be made most interesting. A case has been transferred from the South Kensington Museum, with descriptions by Mr. J. A. Abbott, the study of which would prove most instructive; it is an unwritten book on bee-keeping. Here are specimens of comb in all sizes and forms; worker, and drone, and queen cells; natural and artificial comb; comb infested with wax-moth; larvæ and pupæ; specimens of all races of bees—Ligurians, Cyprians, Svirians, hybrids, &c. It is a collection made evidently with a love to the work, and is well worthy of a position in a public museum.

Since writing the above notice, we have been informed that numerous additions have been made to the collection; among others, an excellent exhibit of honey as medicine, and a collection of seeds of flowers sought after by the bees by Messrs. Sutton. These will make the exhibition much more complete.

## ASSOCIATIONS.

### BRITISH BEE-KEEPERS' ASSOCIATION.

Committee Meeting held at 105 Jermyn Street on Wednesday, May 14th. Present—Hon. and Rev. H. Bligh (in the chair), Rev. G. Raynor, Rev. F. T. Scott, Rev. F. S. Slater, Captain Bush, R.N., Captain Campbell, R.N., J. M. Hooker, H. Jonas, D. Stewart, W. Martin, and the Secretary. The minutes of the last Committee Meeting were read, confirmed, and signed.

A letter was read from the Council of the International Health Exhibition, inviting the Committee of the British Bee-keepers' Association to arrange for a Conference on the subject of bee-keeping, to be held at South Kensington on August 7th. Resolved, that this proposal be accepted, and that the Exhibition Sub-Committee do make the necessary arrangements.

A letter was read from Messrs. Sutton & Sons, seedsmen, of Reading, stating that they were prepared to issue a price-list of seeds suitable for growing plants to produce honey and pollen, to be sold to members of the British and the County Affiliated Associations in small packets at a very low price. Resolved, that Mr. Cowan be requested to name the value of each plant in the list submitted by Messrs. Sutton, either for honey or pollen producing purposes, and that the list so revised be returned to Messrs. Sutton for publication.

The County Associations Sub-committee reported that decisive steps were now being taken towards the formation of County Associations in Monmouthshire, Glamorgan-shire, Pembrokeshire, and the remaining counties in South Wales. A letter showing the benefits which must accrue to the residents of the United Kingdom had been published by the Chairman of the Sub-committee in each newspaper issued in South Wales. Resolved, that the Sub-committee be empowered to publish similar letters in other counties where desirable.

The Examination Sub-committee presented their scheme for the examinations of candidates desirous of becoming experts. Resolved, that the same be approved, and duly published in the *B. B. Journal*. The Hon. and Rev. H. Bligh, the Rev. G. Raynor, the Rev. E. Bartrum, the Rev. F. G. Jenyns, and Mr. T. W. Cowan were appointed as the Central Board of Examiners for the present year.

Resolved, that the Rev. E. Bartrum, Mr. C. E. Fletcher, and Mr. J. M. Hooker, be requested to act as judges of bees, hives, honey, &c., at the Royal Agricultural Show to be held at Shrewsbury in July next.

The Rev. F. S. Slater and the Rev. F. G. Jenyns were appointed to act as judges and examiners at the Hereford County Shows, to be held at Hitchin on July 9th, and at Watford on July 23rd.

The Rev. F. S. Slater moved, 'That in order to avoid the inconvenience often experienced by bee-keepers by the existence of no standard size for 1 and 2-lb. sections, it is desirable that the Committee of the B. B. K. A. shall adopt a standard size in each case, and recommend that these standard sizes be adopted by bee-keepers generally.' Resolved, that the Rev. G. Raynor, the Rev. F. T. Scott, the Rev. F. S. Slater, and Mr. J. M. Hooker, be appointed as a Sub-Committee (with power to add to their number) to consider the desirability of setting forth a standard size for 1 and 2-lb. sections.

The next Committee Meeting was fixed for Wednesday, June 11th.

### PEEL TESTIMONIAL FUND.

A special meeting of the Committee, with the secretaries and representatives of County Associations, was held at the close of the above meeting, to make the necessary arrangements for the collection and disposal of this fund. The following were present—Dr. Walker, Surrey; Jesse Garratt, Kent; Rev. W. E. Burkitt, Wilts; Rev. V. H. Moxley, Berks; Rev. N. Royds, Beds; Mr. J. P. Saubels, Herts; Mr. J. P. Jackson, Lancashire; &c. After some discussion, the following rules and regulations, as moved by the Rev. F. S. Slater, and seconded by the Rev. F. G. Jenyns, were carried unanimously.

### RULES AND REGULATIONS.

That the fund to be raised shall be invested, and the proceeds shall be applied annually in grants to Affiliated County Associations, for the advancement of bee-keeping amongst cottagers.

That such grants shall, if the fund is sufficiently large, be made to two or more Associations in every year.

That no individual grant shall exceed the sum of five pounds.

That no Association shall be entitled to share a second time until every Affiliated Association has had an opportunity of participating in the benefit of the grant.

The Associations entitled to receive the grant shall be selected annually by ballot, such ballot to take place at the Annual General Meeting of the British Bee-keepers' Association.

Each County Association shall make its own arrangements for the disposal of the amount allotted to it, such arrangements to be submitted and approved by the Central Committee previous to the amount being paid.

That the funds shall be invested in the names of the Trustees, for the time being, of the British Bee-keepers' Association, in such securities as Trustees may lawfully select; and that the proceeds shall be paid annually to the Committee of the British Bee-keepers' Association for the purpose of distribution among the Affiliated Associations entitled thereto.

The Committee of the British Bee-keepers' Association shall be empowered to make all necessary regulations in respect to the distribution of the annual proceeds.

Subscriptions shall be received by the Secretary of the British Bee-keepers' Association, and by the Secretaries of the several Affiliated Associations.

The amounts collected by the Secretaries of County Associations shall be remitted to the Secretary of the British Bee-keepers' Association, and entered separately in his accounts of the fund, under the name of each County Association.

## SHROPSHIRE BEE-KEEPERS' ASSOCIATION.

On April 5th, 1884, an adjourned meeting was held of persons interested in bee-keeping at the Mayor's Court, Shrewsbury, for the purpose of electing a new secretary upon the retirement of the Rev. the Hon. C. Feilding. As it was impossible to find any one willing to undertake the office of secretary, the Rev. J. H. Charter was elected Treasurer, to hold the balance in hand until next year, when it was hoped somebody would come forward. The meeting concluded with a vote of thanks to Mr. Feilding for his services during the past seven years.

## WORCESTERSHIRE BEE-KEEPERS' ASSOCIATION.

A meeting of the Committee was held at the Guildhall, Worcester, on May 17th, at which it was resolved to hold the annual show of bees, hives, honey, &c., at Pershore on July 29, 30, and 31 next in conjunction with the meeting of the Worcestershire Agricultural Society. The schedule of prizes will be seen in our advertising columns, and as the time fixed for holding the show will be a good one, we trust that the entries will be numerous and the exhibition a success.

## RUDIMENTS OF BEE KEEPING.

## FEEDERS AND FEEDING.

(Continued from page 131.)

Constant spring feeding in suitable quantity, if carefully carried out, will, in a short time, produce a marked effect on our stocks. If a hive in good condition is treated thus, it is surprising how soon the amount of brood will increase, and the young bees, as they hatch out, will add to the strength of the hive, and make it possible for a still larger amount of brood to be produced. Should the hive already contain a supply of sealed store, it will not be necessary, or desirable, to give the bees any syrup until the store they already possess is in great part consumed. Instead of putting on the feeding-bottle, we need merely uncap the honey in the hive little by little. The bees will commence restoring it, excitement in the hive will ensue, and the queen, thinking honey is plentiful, will commence laying with a will. Every bee-master should take special pains in spring to ascertain constantly the amount of store each hive contains. If he has uncapped most of the honey, and this has resulted in a larger daily supply being seen required to maintain the increasing number of bees, it is evident that the hive will starve unless syrup is supplied to it, or honey in considerable quantity is being gathered. A stimulated hive requires additional care in this respect, and its wants must be supplied artificially, if they are not satisfied naturally. It is needless to point out that the above remarks apply equally to the case of a hive which comes out of winter quarters with hardly any food remaining. Indeed, in this latter case, greater care and watching are required. It will be found, too, in the case of a hive which has wintered badly, that the small number of bees it contains prevent a rapid increase in the amount of brood reared. The bees will not be sufficiently numerous to keep warm more than a limited amount. Hence we shall not so rapidly be repaid for stimulating a weak hive, and an additional reason arises why we should never winter weakly stocks, but rather mite them to others.

In moveable comb hives, the advanced bee-keeper employs yet another method of producing brood more rapidly than the bees (if left to themselves), naturally would. By placing empty combs from the outside of the hive into the centre, and by adding additional combs, he induces the queen to fill them with eggs, and a large number of young bees are soon hatching out. Great care, however, is required in practising this plan, since

if you get too many frames filled with eggs the bees will prove unequal to the task of rearing them,—they will become chilled,—and serious mischief will be produced. Let the beginner therefore be very cautious in this respect until he learns, by experience, how far he can safely adopt the plan.

If bee-keeping is to be made really profitable, it is absolutely necessary that we should stimulate our hives. People sometimes are led into the statement that 'if the bees cannot gather what they require, they must take their chance.' This, it is needless to say, is both inhuman as well as unprofitable. If a little feeding makes our bees additionally profitable, and often saves them from death itself, is not the small amount of expense and extra trouble well repaid? Would not the loss of a valuable stock prove far more serious?—F. S. SCLATER.

## COMB HONEY IN SECTIONS.

By T. W. Cowan.

(Translated from the *Bulletin d'Apiculture de la Suisse Romande*.)

(Continued from p. 161.)

When all the sections are arranged in the rack and pressed together with the wedge *A*, fig. 26, they are ready for placing upon the hive. The colony should be very strong before the sections are put on and should have been stimulated at the proper time. Of course, the time varies according to the locality; but, with us, we usually commence to stimulate our colonies six weeks before the great honey yield. As we require the honey to be stored in sections, we must keep the brood-chamber free from honey and full of brood. With this object in view all the honey in the combs should be extracted; but this must be done with the greatest care, so as not to damage the brood. If the extractor is worked at the proper speed, the honey will be driven out, whereas the brood will remain; but if the speed is increased in the slightest degree, the brood will also be thrown out. Only two combs should be extracted at one time, as brood-combs should be out of the hive as short a time as possible.

The foregoing instructions having been followed, the proper time for putting on the sections is when honey is coming in plentifully. Sometimes it is found difficult to make the bees work in the sections. In such a case the sections are placed in a frame fig. 28, 2 inches

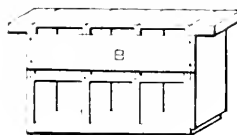

Fig. 28.

wide having no top bar and furnished on one of its sides with tin separators. One of these is seen in position at *B*; the other being removed to show the sections. This frame is placed in the body of the hive, at one end with the separators towards the cluster of bees and a division-board on the other side of frame. The bees will immediately begin to work on the comb-foundation, and as soon as the cells are well drawn out, the sections are taken out, and placed with the adhering bees in the rack above. The bees in the body of the hive finding their companions at work above, soon join them and the work will progress rapidly. Bees begin sections more readily in the body of the hive, but finish them much more quickly above. The end sections can be furnished with glass on the outside, *C*, fig. 26 so that an idea can be formed of the progress of the

work within; but the bee-keeper must not depend upon this; he must examine the sections frequently, and as soon as he finds one finished it must be removed and another put in its place. The rack should be covered with a quilt, and when this is removed the bees are driven down by a few puffs of smoke, the wedge is withdrawn and the sections separated. Examine the centre ones, as these are always the first finished and remove the completed ones. Lift out the section carefully and give it a sudden jerk in the line of the comb to shake off the bees on to the alighting-board at the entrance of the hive. Place the sections partly filled in the place of those taken away and fill up the vacant space with empty sections. This examination must be made every two or three days whilst honey is coming in very rapidly, and this for the following reason: if the sections are allowed to remain in their places after they are capped over, the bees add wax to the coverings, and in running over them they become discoloured. The added wax is a loss, as the honey consumed in its production could otherwise have been stored. There is also a loss of time, because in place of occupying themselves with this they might be filling other sections. The sooner the sections are removed after they are completed the better they look, and the cappings of the combs should be so thin as to be almost transparent. Occasionally the outer cells next to the wood are not sealed over, as they are the last filled; but the bee-keeper need not trouble about these, but should remove the section when the surface is sealed over. As soon as a section is removed it is placed into a crate shown in fig. 30, and which holds about forty-eight sections.

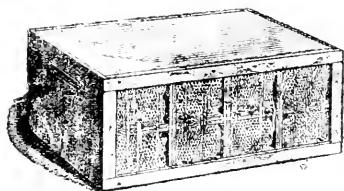

Fig. 30.

When this is filled the sections are assorted according to quality, and are then placed in travelling crates which are of a similar construction to the other, but made to hold only from one to two dozen. In these crates honey can be sent without danger by railway if care be taken to place glass on the two sides so that the railway authorities could at once see what was inside. The sections placed on the top of the hive must be well protected and kept warm by means of coverings, otherwise during cool nights the bees would abandon them, and thus much time would be lost. It is for this reason that some persons prefer the racks with closed sides shown in fig. 27, but this is not as convenient as the rack, fig. 26, for removing the sections.

Others use sippers in which are hung frames containing three sections furnished with separators as in fig. 29, but

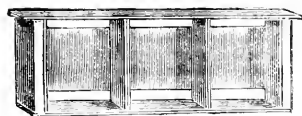

Fig. 29.

these present the same disadvantages as the closed-sided racks; moreover, when an examination is made three sections must be lifted out at a time.

When it is intended to put a rack of sections on a

hive, after removing the quilt it should be placed in such a way that the line of sections runs in an opposite direction to the frames in the hive. If the rack does not completely cover the top of the frames strips of wood can be placed to prevent the bees getting out. Sometimes two or three racks can be worked at a time placed one upon the other.

Sometimes, notwithstanding that the bees have given them abundance of room in the sections they persist in swarming. In this case I remove all the frames from the body of the hive and replace them by frames containing comb-foundation, after which I return the swarm and replace the sections. The work is then continued without interruption and the swarming fever is checked.

When, in preparing a colony for receiving the sections all the honey in the brood-chamber is extracted care must be taken that the bees do not perish from hunger; and if the weather be unfavourable, small quantities of food must be given to them according to their requirements. However, when the sections are put on the bees should no longer be fed or they might store the syrup in them and thus spoil them. In this way beautiful sections may be obtained at a profit to the bee-keeper; the rule to bear in mind being that the body of the hive be reserved for the brood only and that the bees be forced to store the honey in the sections. Occasionally the queen may get into and spoil some of the boxes, but this must not be a reason for using perforated zinc between the hive and sections, as this hinders the work of the bees and reduces the harvest. In a good neighbourhood, with proper management, hives worked upon this principle should give 100 lbs. each in sections, besides some extracted honey in the autumn.

#### 'EXCELSIOR' HIVES, OR EVERY COTTAGER AN AMATEUR HIVE MAKER.

(Continued from page 183.)

We now come to the most important part of the hive, viz. the frames, and on this part I have spent more thought than on all other parts of hives and bee-culture put together, and still I have not got the matter reduced to the condition I should like. Let us just consider some of the difficulties. In the frames as sent out by all hive-makers the sides are cut off square, and the top bar is at least plain underneath, and nearly all have to be nailed in a block, one nail is not sufficient to hold them, and if two or more are used one nail is sure to get struck more than the others, thus crushing the fibres of the wood forming the top bar, and when the frame is turned round to nail the other end the opposite corner will get treated the same, thus causing one frame-side to stand out in one direction, and the other side the contrary, or both sides may stand out of true in one direction, thus causing the combs which may be built or transferred into them, to be not interchangeable; this is a fault which may be noticed in most prize hives at shows by just reversing the frames. So soft is pine, and the almost impossibility of striking a number of blows, having exactly the same force, even by a skilled joiner, I have come to the conclusion that it is next to impossible for a cottager to nail plain frames together, no matter how true they may be cut. So to meet this difficulty (which I have sadly experienced in my frame-making, though I don't consider myself a novice) I have designed a dovetailed frame, see Figs. 8 and 9; if these cuts are done exactly true, and a little glue is brushed round where Figs. 8 and 9 join, and a small pin driven through the sides, the frame will be firm, rigid and true, and, what is more, no block will be required, and any child almost can put them together. Another difficulty in putting plain frames together is getting suitable nails in country places; if they are long enough, they are too thick, and so on; I have met with it

in this large town, no ironing or keeping *every* nail which is made.

I prefer wide-shouldered frames before all others, not merely as distance-keepers, but by placing the shoulders on alternate sides,  $\frac{1}{2}$  an in. more base is obtained, and when all are close together they are practically all one solid lump, safe to travel anywhere; those with metal ends do not allow of the smooth even surface on the top which those cut all in wood do.

Now, as to cutting these frames, I must confess that I do not at present see how cottagers can do it themselves without suitable tools; neither can I see how they can afford to get minutely true ones made, even if they were able; and as I should be in the position of a doctor, ordering things that could not be obtained if I left the matter here, I have made arrangements by which one dozen frames, with two tops extra (one for dummy and one for front), will be sent per pair 1 post for 1s. 10d., along with suitable nails, to anyone sending for them; *6d.* of this is for postage, so the price here will be 1s. 1d.; "Association Plain" will have 17 in. top bars, and plain shoulders, "Association Wide" will have 15 in. top bar and wide shoulders, and will interchange with Abbott's, Edey's, or any other maker's of alternate wide-shouldered frames, no matter which way the shoulder may be fixed; my sized frames will be sent at the same price, or any other size, cut to order, at from *3d.* extra; all wide-shouldered frames will have a long wire nail through them to prevent the shoulder breaking off. I consider I have now put it in the way for every cottager to make his own lives complete, and these arrangements about supplying the frames will continue in force until either I or some one else can find out how they can be home-made.

I now come to fixing in the foundations. If we split the top bar it weakens it; and, what is more, allows moths to get down the middle of comb and destroy it, whilst bees can't help themselves; and if a fresh sheet of foundation is required to be put in, just consider the difficulty of clearing out the old comb and getting the frames home again. If sides, in every sheet,  $\frac{1}{2}$  of an inch is wasted in the top bar, which is equal to 5 per cent if full sheets are used, and 20 per cent if 1-in. strips are put in for guides; so if one will only think about it they will soon come to the conclusion that a better way is desirable. On referring to Fig. 8, two lines x, which should be plain sewing or knitting cotton, are threaded through a hole near the bottom of frame side (this plan is the invention of Mr. S. F. Clifton, see *Journal*, page 121, Vol. XI.; before I saw it I simply slipped a piece of elastic cover, which I removed every time, but I like this plan very much better), between which the sheet of foundation should pass, and which will thus be held firmly in the centre with no fear of its toppling over. I now turn the frame and foundation upside down, and with Fig. 16 (which is the old wax guide-maker) in the left hand, I put off against it, the guide puts the foundation in the centre of frame, which, of course, it must just touch from one end to the other, and I just hold it in place with the tips of the fingers; with the furthest end of frame tilted up I now take a little hot wax from a glue-kettle in the wax-spoon, Fig. 15, and beginning at the extreme end, just run a



Fig. 15.—Wax-spoon: dotted lines show original shape.

little wax out of it in the corner formed by the foundation and frame, drawing the spoon forward from one end to the other, like you would use a brush; the hot wax quickly sets, fastening the foundation and frame-top together, and so neat is it done that the melted wax run in can scarcely be seen. After doing one side you may take away the guide and run the other side down the same way, when the foundation will be as safe as between

split bars. The threads should be left in for the bees to remove, as it will keep the foundation from moving about, and, perhaps, breaking down. When foundation is fixed into sections by means of the spoon, the most clever expert could not detect how it had been fastened up, as



Fig. 16.—Foundation Guide.

there will not be a trace more wax than what the bees would use in a natural way, and all bee-keepers who wish to fix foundation quickly and cleanly I would beg of them to give this a trial; in putting foundation into sections the strings are not required.

The spoons are made from ordinary teaspoons, knocked round with a hammer, as shown in Fig. 15, not half a minute's work; two should be used in a kettle of hot wax, so that one will be getting hot while the other is being used and getting cool, for they must be hot in use, or they would cool the wax, and everything depends on using it hot; the kettle may be a glue-kettle, or one tin can inside a larger one; and so beautiful are old tin cans for the purpose I consider it a waste of money to buy a glue-pot.

The spoons may be the commonest possible, and are very cheap to buy, but people who have some marked A. L. P., which looked like real silver when new, but which turned into brass after a few days' wear, and were thrown in one side in disgust, may now bring them into use again.

I am aware this plan of fixing foundation is somewhat of a retrograde movement, as the foundation was formerly fixed by means of brushing hot wax down the point, running hot wax down it, and running hot wax from a smelter; this last was expensive to buy, clumsy to use, and very often by tilting it up a little too much flooded everything with hot wax; but the spoons are just the thing, as you can just take as much wax as you require, and by means of the spoon (formed by bending them) and capillary attraction, we can do the work as it never was done before. So those who have been annoyed with moths in the slits of top bars, and who have found a difficulty in putting foundation into sections, I say, just give this plan a trial (the only necessary expense is the spoon), and I venture to say as soon as you have got in the way, you will be delighted with it; putting foundation into sections nearly as quick as they can be picked up and put down again, and no means of telling how it was done; whoever daunt of such a thing?

I think I have now given full and complete instructions, and the drawings will be easy to understand, as they show how the different parts are joined, but should any part not be sufficiently clear to anyone I shall be happy to endeavour to make it so. But let me here state that should the hive be required to stand on legs (which I do not approve of, as mice can run up them) they must be secured on at the corners, but I prefer to stand it on an empty box some 6 or 7 inches of overhanging ledge, which completely sets mice at defiance.

The ready-painted boxes which I mentioned at the beginning are to be got at the wine and spirit merchants; they are known as "Green H. Lanes," are marked JOHN DE KUPER & SON in a half circle, with an anchor in the middle in white-paint letters; there is also J. D. K. & Z, with an anchor above, branded on with burnt letters; so there is no mistaking them. They are 11 in. wide, 10 in. deep, and 11 in. long, inside measure; they are just right for my frames, and will hold Association frames very well, as bees do not readily build below the thin bottom bar; but if they are used for Association frames I would advise 1 in. being cut off, either the top or bottom.

By means of the gimlet and saw-pat a slight-hole is

cut; by means of the saw and square the lid is cut into a plain dummy, a frame top-bar is nailed to it, and one on the front of the box, and seven broad-shouldered frames dropped in. A piece of felt is cut to cover the top, a strip of wood nailed on each side, to one of which two pieces of leather can be nailed to form hinges, a staple or screw-eye in the other, and one in the box, completes it; or, it may be done as Fig. 17, the five strips being cut

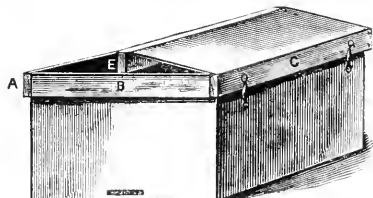

Fig. 17.—Makeshift Hive. From a 'Green' Hollands Box.

from slating laths, and the hinges formed by threading twine through screw eyes; it will just hold seven frames, and the division-board if left perfectly plain.

These boxes are the most handy things possible to act as makeshift hives, nuclei, and storing frames or combs in. They charge me in this town 6d. each for them, so who would be without a bar-frame hive, when one can be got ready painted with frames, and roofed, for 1s. 6d.—not the price of a skep with floor-board and cover? They could be easily worked in piles on the Stewarton principle, but I have not tried them this way yet, but I see no objection to it. Fig. 17 shows one of these boxes converted into a makeshift hive; the five strips A B C and E (D being out of sight, but is like B) are cut from slating laths  $1\frac{1}{2}$  by  $\frac{5}{8}$ ; A E and C should be  $11\frac{1}{2}$  in. long, and B and D  $16\frac{1}{2}$  in., and nailed together as shown, a piece of roofing felt is then nailed on to A and C; the hinges are formed by threading twine through screw eyes, both sides being treated alike, the loop of twine is slipped over the bottom eyes, and sticks pushed through, which prevents it slipping off, or the wind lifting the roof off; either side will thus be hinged, and the roof can at once be lifted off, when the box—or hive rather—is not wanted to stand out-of-doors; strong twine or rope threaded through the eyes on each side will form a handle to carry them about by; E will rest on the quilting, and keep it from blowing up, and plenty of air will be able to pass over it to keep it dry.

To those bee-keepers who have not seen these boxes—and I have never seen or heard tell of any one doing so except those I have told myself—I would say, Inquire for them, and you will be well satisfied; they are made from  $\frac{1}{2}$  an in. white deal, well painted green, and are what those square bottles of Hollands or Geneva gin come in.

I hope I have made hive-making a very simple matter, and put it in the way of every cottager being an amateur hive-maker; and, perhaps, those of them who are in want of a job, or a rainy day, may be able to go to the grocer's, get a box, make it into a hive, and sell it to some neighbour who wants one, but has not time to spare to make it, or, if it is nicely finished, perhaps the squire or parson would readily buy it in preference to one double or treble the price. If by these instructions I have done something to popularise bee-keeping amongst cottagers, and enable them to extract a little honey (or money) out of time as it passes by to make existence more pleasant, I shall feel well repaid for the hundreds of hours I have pondered the matter over the past four years.

In these hives I have selected the 'longitudinal' principle, for this seems the best of any for universal use; it enables us to just give as many combs as the queen can fill with eggs—the power of egg-laying in queens varying

as much as 50 per cent—and by removing the back combs and pushing the dummy-board up to the brood, we can force the bees at once into the supers.

I have provided for no queen-excluder zinc, as it is not infallible—I should very much like to see the zinc which will hold back a hybridised Syrian queen and pass the workers—and as bees can be managed without, obviously it is bad policy to introduce it, if we wish to simplify bee-keeping.—JOHN HEWITT, *Sheffield*.

COOK'S 'MANUAL OF BEE-KEEPING.'—We have much pleasure in directing the attention of our readers to the large circulation which has been attained by this practical and instructive work. Its twelfth thousand has recently been issued; and this fact is the best evidence of its utility as a guide to bee-keeping, and the appreciation it has been favoured with by apianians both in America and in this country.

#### AN APOLOGY.

In a letter in our last issue signed John Hewitt, Sheffield, on 'Blacks v. Ligurians, and other Foreign Bees,' some expressions appeared which Mr. C. N. Abbott has understood as an imputation on his character. We deeply regret this. Our appreciation of Mr. Abbott's character may be estimated from the position taken by us when the Testimonial to him was raised; and nothing has transpired since that time to cause us to retract therefrom. We therefore desire to take this the earliest opportunity of apologising to him for permitting the remarks to appear in our paper, and to express our sincere regret that any words in the *Bee Journal* should have found insertion to cause him any uneasiness.

## Correspondence.

All Correspondents forwarding Letters for insertion in the Journal, Reports of Associations, Shows, Meetings, Echoes from the Bees, Queens, &c., are requested to direct their communications to 'THE EDITOR of the "British Bee Journal," 27, Messrs. Stangeros & Sons, Tower Street, Upper St. Martin's Lane, W.C.

#### OUR HONEY IMPORTS.

The value of honey imported into the United Kingdom during the month of April, 1884, amounted to 4962l. (From a private return sent by the Principal of the Statistical Office, Custom House, to E. H. Bellairs, Wingfield, Christchurch.)

#### HONEY MARKET.

Thanks for the insertion of my letter in last issue relative to the formation of a honey depot in Berkshire for honey (pure and unadulterated), run, and sections from all parts of Great Britain and Ireland. I only regret that the kindly article wherein you alluded to the admirable way in which my suggestion is being so practically taken up in numerous directions should have contained anything at all approaching to unkindly comment on the fact of the last General Meeting rejecting the idea of a honey market in connexion with the British B. K. A. With that decision, although a member, I had nothing to do. My own idea is that such a work is better left to individual enterprise, based upon sound and business-like principles, at all events for the present.

Offers of honey, run and comb and wax are coming in from all parts of Great Britain, and the more the better, as while Huntley and Palmer will be and are large consumers, other branches of industry also use and require honey and wax for different purposes, and



it will tend to 'focus' the work the more widely it becomes known that the promoters of the 'honey depot' will at all times buy (subject to their analyst's satisfaction) pure British or Irish honey, extracted or in sections, or wax, and also pay carriage to Reading by goods train. The knowledge of this fact will be a help to all present and intending bee-keepers. The prices of course will vary with the seasons, but full wholesale price will always be given.—V. H. MOYER, *Brook House, Burghfield, Reading.*

#### COUNTY ASSOCIATIONS.

In the absence of the Chairman of the Sub-Committee of the County Association business of the B.B.K.A., I send you some remarks in reference to Mr. Riggall's letter in the *Journal* of May 15.

The principal privileges of association offered by the B.B.K.A. to County Associations are briefly as follows:

1. Information on all subjects connected with the advancement of bee-culture.
2. Representation at quarterly conferences of the Central Association.
3. The gift annually of two medals and a certificate, to be offered for competition amongst members as prizes for honey.
4. Free use of a bee-tent and of the services of a judge at the annual county show.
5. The enjoyment of any facilities provided by the Central Association for the sale of honey.
6. The examination of experts for certificates.
7. Participation in the benefits of the Poel Testimonial Fund.
8. The admission of members to the 'Bligh' Competition.
9. The purchase of the publications of the Central Society at the ordinary trade-price.
10. To newly formed and weak County Associations the services of a representative of the Central Association, free of all expense to give lectures or other assistance.

As Mr. Riggall's letter may be understood to imply that the Central Association not only offers these privileges to County Associations, but is also responsible to individual members for their application, may I be allowed to point out that the internal organization and management of each County Association rest entirely with its members, and the enjoyment of the privileges of affiliation offered by the B.B.K.A. is conditional only upon the fulfilment of certain conditions.

Mr. Riggall, in his letter, represents the Lincolnshire Association as being in a sorry state indeed. But the removal of the 'trap' he speaks of, if such exists, is in the power of the county members alone. I have not, unfortunately, a copy of the Lincolnshire rules by me, no report or balance-sheet having been received by the Central Association since 1880, but I am given to understand that, in an early copy of these rules, it was provided that, at the request of a certain number of members, the Secretary shall be compelled to call a general meeting, to remedy any special grievance. It may be that the indolence or indifference of the County Secretaries accounts for the instances we find of weak Associations, which fail in conferring benefits on their members, or in applying in an efficient manner the privileges of affiliation offered by the Central Association. If this be the case in Lincolnshire, where is the Committee of management? Its members are responsible for the proper management of the Association, and should see that their subordinate officials are working satisfactorily. Let a sufficient number of members forward a request to the Secretary to call a special meeting. Let that meeting ascertain the causes of the present weak state of the Association, and devise a remedy.

Should the Lincolnshire members so desire, I feel sure

the Committee of the B.B.K.A. will give them every assistance in giving new life and vigour to their organization. The success which attends the efforts of the Central Association in this respect is plainly marked in the many strong Associations which of late have been developed, and it is certainly a subject of much regret that Associations, through mismanagement, should be allowed by their members to fall lower and lower in the list, and perhaps eventually lose the benefits of affiliation by failure to comply with the conditions. Such a result invariably points to inefficient management, and the necessity of reorganization. May we not hope that our weak Associations will recognise the necessity of electing a hard-working Committee, of appointing an energetic County Secretary, and of uniting their members by such an organization as will best assist members individually, and spread bee-culture generally within their respective counties?—FRANCIS S. SLATER.

#### PURIFYING BEES' WAX.

At the Health Exhibition I saw some very nice little moulds of bees-wax, exhibited, I think, by Mr. Godfrey of Lincolnshire. I do not know how to get the dirt and impurities from the wax, nor how to turn it out in these nice little moulds, but have only bits of refuse wax at a time. Mr. Godfrey would be doing a service if he were briefly to communicate through the *Bee Journal* the *modus operandi*, so that small bee-keepers could accomplish the desired result without the costly paraphernalia advertised by dealers.—R. E. C.

#### DISTRICT ADVISERS.

The increasing importance of appointing, by County Associations, District Advisers or Secretaries is a matter which requires ventilation in the columns of this our medium for the interchange of apianian ideas and suggestions. Who and what description of person is the most fitted to fulfil the duties imposed upon them by such a position? It must of necessity be one who is well posted in the humanitarian cultivation of our little labourers, the honey-bees, that is one great desideratum. Next in importance it becomes one to possess a ready tact in answering questions, in order as much as possible to avoid giving offence to the questioner on matters relating to his superstitious ideas, which we must remember have been inculcated in the minds of the peasantry from generation to generation. Nothing is gained, but everything is lost, by ridiculing this ancient bee lore. If such is done, 'Hodge' will answer, 'I know it be so,' and turning on his heel will avoid any further controversy on the subject; better by far pass such ideas over by an answer at first, such as, 'Ah, well, that's strange, but it never occurred to me, and gradually at different meetings endeavour to eradicate such fallacies from his mind; it's easily done, as I have experienced, and no offence given. Superstition among the peasantry in this neighbourhood is very rife on bee matters.' Last week I came across an incident which, with a little management, I showed the questioner the fallacy of his notions. He said, 'I know my bees be going to swarm as soon as I see them drawing the young bees out, and chucking 'em on the ground outside.'

Another adjunct for a district adviser is the means of locomotion, as such an office must of necessity be an honorary one, and as long distances have to be got over somehow, walking would be out of the question. In some cases, as in my own, it would be of small consideration, as business necessitates my visiting nearly every part during the week for five or six miles round, but every one is not so situated. This is a matter which I think we shall find will be very troublesome, and I really do not seem able to suggest any plan to surmount it, except the only one of appointing one whose business takes him

much abroad in his particular neighbourhood. But, by-the-by, I had forgotten the cyclists. People get used to see you continually pass by, and are not then so adverse to stopping you, and asking that which they want to know; they also get more familiar with you. I have noticed them come to their doors at first with a 'Good morning, sir?' when, perhaps, the next time you pass, it's, 'Could I trouble you to step inside, and look at my bees?' This is always the commencement of an apianian friendship, and the consequent upsetting of his or her killing-the-geese-that-lays-the-golden-egg and inhuman treatment of their little labourers. I should also consider that a District Adviser ought to pass an examination at county headquarters, to see whether he is as conversant with modern bee-cultivation as would be necessary for the proper fulfilment of his duties.

I myself feel confident of the good results which will accrue to the County Associations if they will go in heartily and take the matter up with earnestness. Members will increase, and consequently the Associations will flourish, whilst very many of the labouring classes will have their rent gathered in upon the wings of their numerous dependents, and their minds and bodies stimulated with something better than the usual quart.—  
W. B. WEBSTER, *Wokingham, Berks.*

#### CERTIFIED EXPERTS.

With reference to the letter of 'Paddy,' in your issue of May 1, respecting certificated experts.—I consider the suggestion to be one of the greatest value, and will gladly send in my subscription of 1s. and undergo the examination necessary to obtain a certificate should this scheme be carried out.—DUBLIN.

#### ANOTHER POINT GAINED.

For some years past I have striven to solve the problem of feeding dry sugar to bees, and at last I am pleased to be able to record that I have a system of stimulative feeding which enables me to give the sugar in such a manner that there is not the slightest waste; the food is placed where it is readily accessible to the bees at all times, and during any weather. I am saved all cooking, my feeders cost me next to nothing, and require attention less often than it is necessary to examine hives during stimulation. I find it no small advantage to be able to dispense with the daily 'round' with the syrup-can, and have nothing sticky about.

All my dummies are composed of a frame of the usual size, but 1½ ins. wide, or thick; one side is closed entirely with a board ½ in. thick, while for the purpose of feeding, the other side has a piece also ½ in. thick, reaching from the bottom to within ½ in. of top-bar, for the bees to enter by the slot thus left, and this board is fastened by a wire nail at each end near the bottom edge, permitting it to open out as if on hinges. When closed, a wire nail is also driven nearly home through the frame at each end, near the top edge. These nails, thus arranged, form a most simple but effective hinge and fastening, and those for the latter purpose are readily withdrawn with the pinners when necessary.

When ready, the box is filled up level with the slot with genuine Porto Rico sugar, and then placed to one side of the brood-nest, acting as an ordinary dummy. Each holds nearly three pounds at a time, and according as one is almost emptied, another 'dummy-feeder' is inserted at the other side of the brood-nest. At the same time a sheet of American cloth is placed next above the frames, and on this more than sufficient water will condense to enable the bees to reduce the sugar to syrup; this they will do but little faster than it is required for brood-rearing, and the queen is never crowded out; while the stimulation is so great, that if sufficient old

stores remain in the combs, spring feeding by this means need not be commenced until nearly a month later than with syrup feeders, and even then those colonies having the dry (or rather moist) sugar will take the lead.

The most perfect system of stimulative feeding with syrup is that of giving a 'gentle, continuous supply,' introduced, and so persistently advocated, by Mr. Abbott. By that plan we permit only a few bees to work at the syrup at one time; and while they know they have a constant flow, they do not know how much there is behind, hence they proceed too cautiously, as compared with my box-feeder, wherein many hundred can work at the food, being aware that they have a large quantity to depend upon; thus a higher temperature is induced, and brood-rearing goes on just as it does during a honey-flow.

The boxes must not be wider than the size given, or comb will be built in them; and if 3 lbs. are not sufficient at one time, more feeders can be added. It must also be understood that the bees are to be crowded on to these feeders, just as they are (or should be) on to the ordinary dummies. When crowded with bees working at the sugar, these combination dummies are warmer than with chaff-packing, but for winter any kind of warm material can be inserted if thought desirable, then turning the slotted side away from the bees. The Porto Rico sugar is to be used only in spring and for producing young bees in autumn; but for winter stores the best grade of Demerara will answer admirably, keeping at least two full boxes in at one time for fast feeding.

It is not my intention to enter upon any discussion on this subject. With myself dry sugar feeding is no theory, but an accomplished fact; and while some few will probably be unable to carry it out, the bulk of intelligent bee-keepers, especially those with large apiaries, will acknowledge that the system has great advantages.—SAML. SIMMONS.

#### INTRODUCTION OF QUEENS.

Many letters have lately appeared in the *B. B. Journal* respecting the Simmons's method of introducing queens. Last summer I had an opportunity of testing it thoroughly. I introduced seven queens according to Mr. Simmons's instructions, and I never had a single failure; they were readily accepted by the bees, and were very soon at work laying eggs. If I had fifty to introduce I should most certainly do it the same way, as I have had no reason to think it is not a good and safe plan. Bees are doing very well now, breeding very fast, and some hives are filling supers.—NORTH DEVON.

#### REMOVING SUPERS DURING BAD WEATHER.

In answer to an inquiry on this subject, a suitable moment must be selected for the purpose, such as will enable the bees in the super to return to the hive. The mode of removal will be that employed in ordinary cases. No advantage will be gained unless bad weather appears likely to last, as little honey is obtainable.—F. S. SCLATER.

#### WILLOWS AND FOUL BROOD.

If the honey that is collected from the palm bloom upon the willows is of any use as a cure or preventative of foul brood, it ought to do a lot of good this year; although I very much doubt it, as during the spring of 1882 the willows were as full of bloom as they are now, a certain bee-keeper in this neighbourhood (not a novice at it either), a bar-framist, found he had got foul brood, and, notwithstanding all the precautions he took, and the fact that there were several acres of willows in full bloom within a short distance of his hives, he did not get rid of it all through the summer.—J. FRANCIS, *Tonbridge, Kent.*

## TEMPERATURE OF HIVES.

Your request that I would subject the matter of 'temperature of hives' under various conditions, taking external temperature and amount of food consumed into consideration, to a thorough investigation, has led me to make a few experiments, which are stated in Table I. But I must not claim for them the

results of a thorough investigation, nor can I consider myself to be a scientist, but simply give here a true record of what passed under my observation. To make the figures intelligible to your readers, with your permission, I will add a few words of explanation.

TABLE I.

	TIME OF DAY.	TEMPERATURE IN THE SHADE.	No. 1, B.B.H.					TEMPERATURE IN THE SHADE.	TEMP.		WIND.	RAIN.	BAROMETRIC PRESSURE.	REMARKS ABOUT WEATHER.	REMARKS ABOUT BEES.
			No. 1.	No. 2.	No. 3.	No. 4.	No. 5.		MIN.	MAX.					
Sunday, May 4th.	7 a.m.	54	70	70	82	82	58	61	7	6	S.W.	—	29.8	Wind strong and gusty, but was not down by wind on returning home.	In morning quiet, went to work, but was not down by wind on returning home.
	1 p.m.	58	72	72	85	85	61	63	—	—	W	0.05	—		
	9 p.m.	49	70	70	82	82	57	60	—	—	W	—	—		
Monday, May 5th.	7 a.m.	54	72	74	78	74	55	61	31	58	S.W.	—	29.45	Flying moderately in morning, but quiet after 11 a.m.	Flying moderately in morning, but quiet after 11 a.m.
	1 p.m.	55	75	75	81	80	55	65	—	—	W	0.01	—		
	9 p.m.	42	72	75	81	75	54	60	—	—	W	—	—		
Tuesday, May 6th.	7 a.m.	48	74	71	76	75	51	58	29	60	N.W.	—	29.71	Flying moderately in morning, freely at noon, but went down by wind.	Flying moderately in morning, freely at noon, but went down by wind.
	1 p.m.	50	84	86	90	88	56	68	—	—	—	—	—		
	9 p.m.	38	83	88	98	92	54	70	—	—	—	—	—		
Wednesday, May 7th.	7 a.m.	47	82	86	91	81	51	58	31	78	S.W.	—	29.01	Flying moderately in morning, but kept at home by rain later on.	Flying moderately in morning, but kept at home by rain later on.
	1 p.m.	58	85	86	91	90	56	68	—	—	W	0.1	—		
	9 p.m.	49	86	88	92	82	54	78	—	—	W	—	—		
Thursday, May 8th.	7 a.m.	54	88	88	94	88	58	62	44	65	S.W.	—	29.00	Flying moderately in morning, which increased to freely during day; although it was dull. Nos. 1 to 4 fanning at 9 p.m.	Flying moderately in morning, which increased to freely during day; although it was dull. Nos. 1 to 4 fanning at 9 p.m.
	1 p.m.	65	90	89	96	92	70	70	—	—	—	—	—		
	9 p.m.	51	89	92	94	92	62	70	—	—	—	—	—		
Friday, May 9th.	7 a.m.	56	88	88	94	88	62	65	46	68	S.W.	—	29.18	Flying moderately in morning and free later on, but subdued by wind; Nos. 1 to 4 fanning at 9 p.m.	Flying moderately in morning and free later on, but subdued by wind; Nos. 1 to 4 fanning at 9 p.m.
	1 p.m.	68	95	88	94	97	78	78	—	—	—	—	—		
	9 p.m.	54	94	92	97	94	72	80	—	—	—	—	—		
Saturday, May 19th.	7 a.m.	62	92	91	97	91	70	74	41	78	S.W.	—	29.21	Flying freely from early morning throughout day. Clear and calm.	Flying freely from early morning throughout day. Clear and calm.
	1 p.m.	78	97	96	98	92	94	—	—	—	—	—	—		
	9 p.m.	59	94	94	94	94	81	90	—	—	—	—	—		

Without extending the length of this paper unduly, I feel I ought to say a few words as to aspect of my apiary, kind of hives, &c. Early in 1883 I removed into my present house and garden. The garden is open to all sides except the north, on which the house stands. There is a young hedge planted of white-thorn and privet, which is protected by a rough wood fence; and my garden is pretty well stocked with fruit-trees, and currant, raspberry, and gooseberry bushes, all too young and small to afford any protection. The hives numbered 1 to 6 in the table above all face south; while there is a glimmer of sun, they get it, and they also get the full blast of every wind that blows. I hope to get them more sheltered by-and-by, but cannot for the present until the hedge and evergreens, &c. are grown larger.

The hives, 1 to 4, are bar-frame, double-walled, made by myself, and are dovetailed, not simply nailed together; there is a dead-air space all round; but besides this I have cork-lust cushions which I place outside the dummies to keep the bees warm; and I always keep them in during spring until the hives are expanded to their full complement of bars, so that there is no longer room for them; and I may add, each of them has six quilts on top of bars. Of Nos. 5 and 6 I must say more presently; but I selected these four as being as near alike as possible, and the bees being about equally strong, all natives and all last year's queens, but not of all one strain. Having borne with my description so far, let us examine the figures.

I had been making a few experiments a few days

earlier with Nos. 3 and 4, but did not get everything in satisfactory order until Saturday afternoon ready to commence the following morning. I may add, in no case were the bees alarmed or excited in taking these temperatures. I had taken precautions to prevent that, which were very satisfactory. Sunday was a very squally day, with strong winds from S.W., the wind dropping at night brought on a cold rain, the effect of which is seen in the reading of the outside thermometer, this was followed by a cold night. But Monday morning opened bright with strong wind and flying clouds, which brought on hail-storms before noon, the effect of which on the thermometer is recorded, both inside the hives and out, and ended in a frost early on Tuesday morning, and a low temperature in the hives as well as out-doors; but the sun shone out brightly between the clouds, and as the day wore on the bees flew more freely than they had previously for the week, which raised the temperature in brood-nest from 6 to 10 degrees. From Tuesday night on to the end of the week we got a higher temperature, both inside the hives and out. The highest recorded is No. 3, 98°, Tuesday 9 p.m.; this I will explain more fully in Table II. No. 4 also reached the same temperature on Saturday at 1 p.m.; but this was from natural causes and not from artificial excitement. But what I found in the week previous as well as during these experiments was, that the bees objected to the temperature of their brood-nest exceeding 90°, and as the temperature exceeded that so they increased fanning at the entrances. It occurs to me that they do not fan to

expel foul air, the ventilation at the entrance being sufficient for that, but simply to reduce the temperature; and I also drew the inference that if they are fanning in the evening and the internal temperature is over 90° and the external temperature is less than 60°, you may safely expand your brood-nest as your bees are wasting heat which we may utilise with safety. Having said so much about temperature, I would call your attention to 'food.' You will observe Nos. 1, 2, and 4, do not vary much either in temperature or amount of food consumed, while No. 3 has exceeded the others considerably. I will endeavour to explain this as we look at Table II.

TABLE II.

TEMPERATURE	4 p.m.	5 p.m.	6 p.m.	7 p.m.	8 p.m.	9 p.m.	10 p.m.
Thermometer in the shade	59°	—	—	48°	44°	42°	38°
No. 3 Hive	50	92	94	96	98	98	98
No. 4 "	86	87	90	92	92	92	92

I had been waiting for a day or two for the wind to calm down as I wished to remove No. 3 into a clean hive; and on Tuesday, at 4 p.m., I took the opportunity of doing so; it is identical with the others, only sweet and clean. I always shift my bees, both spring and autumn, into clean new painted hives, and always using one-size frames in all, have no difficulty. Moreover, I have never been troubled with foul brood, although my neighbours have; but I have had dysentery bad enough on more than one occasion. *Young bee-keepers may note this.* My idea of the origin of foul brood coincides with Mr. Cowan's, so I do my best to prevent it, and consequently have never had to cure it. But this is a digression, so we will return to Table No. II. At 4 p.m. the outside thermometer stood at 50° Fahr. inside No. 3 at 90°, same as at 1 p.m. inside No. 4, at 86°, 2 degrees less than at 1 p.m. I had anticipated all my wants, and had three spare frames fitted with whole sheets of foundation ready to hand. I commenced by removing the cover and five quilts and food-bottle of No. 3. I gently drew back the quilt from one side and gave a puff of smoke, repeated the process on the opposite side, covered all up and an occasional puff at the centre-hole to keep all down that attempted to fly, and the internal 'roar' told me they were fully gorging themselves in a panic. I removed the quilt from half the number of bars, and lifted them out into the clean hive. I now removed the quilt on to the bars in the clean hive and removed the remainder, dumming them snugly up and covering all over in about three minutes. As I passed each bar out I cast my eye over each card of brood, and they were such as could only delight any bee-keeper, there was an abundance of bees, a good complement of drones (in Nos. 1 to 4 as well as others I have, had drones flying since Easter Sunday), and brood in all stages of development, and perfect sheets too, no Syrians could possibly have better; there were little or no sealed stores. I had taken care to keep it uncapped earlier in the season; and although I had been feeding all the week, yet the bees had consumed all they had taken down as well as gathered. Having packed No. 3 up securely and set it right, you will see by the table how the internal temperature stood for the next 6 hours in relation to the external thermometer; but I have forgotten to say I inserted one of the bars into the middle of brood-nest, and the thermometer thus stood between a sheet of brood and a sheet of foundation while recording the temperatures here given, so we will pass on to No. 4 which did not require a clean hive. This I smoked as before described, taking care not to inject any into the flight-hole; but simply on top of the bars, to drive the bees down until they had gorged. Having quickly examined a few frames to see all was progressing well, I also inserted frame fitted with foundation into the middle of this hive, the

thermometer standing as in No. 3; but the bees did not gorge so much in No. 4 as in No. 3, consequently did not increase the temperature of their brood-nest so violently, and fanned but little in comparison to No. 3; but with this difference also, No. 3 worked out their sheet in forty-eight hours, but it took No. 4 seventy-two hours to do the same amount of work although equally strong in numbers; but the increase in the consumption of food in No. 3, as you will observe, is considerable for the same time, but they also maintained greatest temperature.

No. 5 was a 10s. 6d. single-wall hive of a well-known maker. I have no fault to find with it, frames, dummies, and sectional supers included, it is good money value; although making my own I should not like to keep bees in anything so liable to be affected by the external temperature. It is not mine, but one placed in my care by a cottager that has left this neighbourhood, who is going to send for it when he has settled down again; he has kept bees in straw skeps for years, and last autumn invested in this hive stocked with bees as a start on the new principle. He gave it into my possession a few days since, as 'a good strong stock which gave 60 lbs. super last year, with plenty of food,' and only wanted garden room for it. They at first flew freely, but just as I was about to commence these experiments I noticed they were very quiet, so I took off the lid and listened, and hearing no movement, I gave the hive a 'jar' which awoke them. On examination I found bees sufficient to fill three frames, but they were on eight; so I withdrew five and dummied them up on three, but not an ounce of food nor a single sealed cell of brood had they, although the queen was young and there were many young bees amongst this small number that remained. Well I did not feel this a very satisfactory stock to have charge of, so I took the temperature and found it little or nothing beyond the external temperature, so I resolved to put a bottle of food on and record the results, which I have given above. On Thursday I found the queen had laid two patches of eggs 'back to back' on centre comb, about three inches across, and there was a slight sound of animation within, the bees evidently 'burning' food to generate heat. I need not comment on the prospects of profit from No. 5 this year at any rate.

No. 6 is an old tough-combed skep, a 'Bligh Competition' of my own. I let it take its chance. In 1882 it gave me 20 lbs. super honey. In 1883 it gave a May swarm, which I gave to a friend, and the swarm filled a large skep and gave 25 lbs. super honey in 64 days from swarming, and I had hoped the old stock had afterwards stored enough to care for itself, but finding no brood in it, I tested that also to see the difference between a weak stock in a skep and a bar-frame hive, with the result here given; but with this difference, the skep has had no food. It is an old 'companion in adversity' of mine; I have taken it many journeys; it has been 'driven' at South Kensington, and nearly drove all the committee out of the tent, and I have driven it myself at several local lectures where my services have been in request; but I put it under stern discipline, it has to shift for itself, but we cannot break the combs down, which makes it valuable at times.

I may say a friend and neighbour of mine, who is a very painstaking naturalist, has tested one of his hives with practically similar results, and has now borrowed a portion of my appliances for further experiments.

As you predicted, I have found this matter of 'Temperature of hives' very interesting, and hope it will be of interest to the readers of the *B. B. J.*, any of whom requiring further information may have it with pleasure, if it is possible to be given by—AMATEUR EXPERIT.

[We desire to thank our correspondent for the trouble he has taken in complying with our request, and for the interesting communication he has given to our readers.]

## PROPER NAMES OF THINGS.

Your correspondent 'Ubique's' letter has, I must say, puzzled me. Does he mean it for a 'goak' (as Artemus Ward calls it), or is it seriously intended? That we should ever adopt such terms I cannot for a moment imagine. Just fancy an expert, on his spring rods, instructing 'Hodge' that he might now venture to insert his 'Utroquals,' and, if the weather permit, try 'Uterials' also. If he finds 'Undicals' not sufficient, then resort to 'Supers' to complete the matter. That evening he would tell his neighbour, 'That expert chap's lin'ere a-talkin' French. I can't understand him; I shall stick to them straw hives—their's the most natteral.'

I find that the terms 'sections' and 'supers' are often more than the limited vocabulary of the country labouring classes will sustain; and to puzzle the learned bee-keeper even in these days of Board Schools with such additions would be fatal to any attempt to induce the adoption of more scientific methods of bee-culture.

The quotation from Locke seems to me most applicable, for many errors would be caused by using words that few would understand the correct meaning of; and the result would be confusion worse confounded. Let us stick as close as possible to plain, simple Saxon, that all may be able to grasp the matter. There are difficulties enough without adding those of long words and intricate terms. I take this liberty of disagreeing with your correspondent, knowing that to many who look anxiously for the coming of the *British Bee Journal* the use of such terms would make the articles quite beyond them, and thereby spoil the good the circulation of the paper among members of County Associations is now doing.—C. BROWN, *Bewdley*.

## REPLY TO 'HAMPSHIRE HOG.'

I had intended to have sent 'Hampshire Hog' an elaborate apology, but time forbids; and he being such a good-natured, jolly sort of a pachyderm will take the will for the deed, doubtless. 'H. H.' had said he meant no malice in the issue of *B. B. Journal* before my letter appeared so that anything more on the point was unnecessary. The cloven foot had disappeared.

'H. H.' already seems to be getting fond of Ireland, as he is initiating the wit of that land and committing *female bulls!*—H. V. E., *Mackworth, Derby*.

## QUEEN IMPREGNATION.

I released and examined a hive at the end of March. I replaced it, as I thought, in good condition, in respect to stores and brood. I must, however, in some way have destroyed the queen during my manipulation. On the 9th of April I again opened the hive and found the brood almost all hatched out and a queen-cell nearly ripe. The weather after this was bad, and I could not open the hive again before the 23rd of April. I then found the queen-cell hatched and a good supply of drones. In my other hives I saw scarcely a drone. On the 10th of May I again examined the hive, there was no sign of brood and the drones had almost disappeared. On the 19th I found eggs and grubs. Are not these facts interesting on two grounds, as, 1, showing the early impregnation of a queen in unfavourable weather; 2, proving almost with certainty that the queen mated with a drone of her own hive?—ABERDEEN.

## A HONEY DEPOT.—STANDARD SECTIONS.

Your just strictures upon the short-sighted policy of the general meeting of the B. B. K. A. in shelving the question of a central depot for the sale of British honey, induce me to again approach the subject in the hope that something may yet be done in the matter. To me it appears the pressing question among bee-keepers and the high talk about privileges of affiliation, membership, &c. amounts to very little, unless an outlet is offered for the

disposal of produce. From my own experience I know what a boon such a depot would be to the cottager, for he has difficulties to contend with unknown to his better-to-do brethren. As an illustration I may perhaps quote what passed between a cottager and a wealthy bee-keeper in my neighbourhood. The gentleman was saying how easily he disposed of a hundredweight to his own grocer in a little southern town, and that the demand had exceeded his ability to supply.

'Ah, sir,' said the cottager, 'I wish you would sell my 60 lbs., I have tried in several places but can find no market. You see people will buy *your* honey and pay you a good price, but they want *ours* for nothing.' It may be asked why did the gentleman not arrange the matter so as to secure the same terms for his poorer friend, but the difficulties of guarantee and the unavoidable trouble in the matter nine times out of ten effectually prevent this.

The whole matter seems to me one of pounds, shillings, and pence, and this I take it was the reason the general meeting discussed the subject. It seems to be assumed on all sides, that the business cannot be made to support itself, and although I am not inclined to go into this branch of the question I may be allowed to express a doubt on this head. At all events, I believe it will be conceded that, properly managed, a central depot would not entail a very considerable loss, and if the manufacture of comb-foundation of guaranteed purity were added to the general business, a considerable return from this branch alone might be expected. All bee-keepers use this commodity, and I need only point out the great safeguard we should have if a responsible body manufactured it guaranteed free from paraffin and *Gaultheroid wax*.

As one who knows something of the details of working County Bee Associations I may say that the privilege of sending to a central metropolitan depot would be of immense value to cottagers; far more so than to any other class, and I believe it would 'pay' County Associations if they had to subscribe £1 a year to obtain such an advantage. But the scheme advocated by Mr. Stewart has always appeared to me as the right one, viz. that a certain number of guarantors should accept responsibility for a limited time and amount. If I remember rightly his estimate required 100 members at two pounds each for three years. This sum was to cover the expense of a sort of club-room. Such a club, centre, or circle, would appear very useful to bee-keepers, and if an appeal was made to the many well-to-do and enthusiastic bee-keepers amongst us I cannot believe it would fail. We have recently witnessed the easy way in which the B. B. K. A. surmounted its pecuniary difficulties, occasioned as I think by far more doubtful enterprises; and I trust Mr. Stewart and his friends may again take up the matter in a more complete form and carry it to a successful issue.

With regard to the proposal for appointing a standard size for sections, which I see is to be brought forward, I trust the committee of the B. B. K. A. will not be so ill advised as to attempt such a subject. The appointment of a standard sized frame was an advantage apparent to anyone, although its adoption in my case involved the condemning of a dozen highly finished edifices; but what advantage would accrue from our all using the same sized sections I am quite unable to discover. If three large apiaries supply the same town, it would surely be to their mutual advantage that each one offered a different article; and I confess if my neighbours sent to my market one pound, one and a half, or two pound sections, it would appear that I must adopt the new half pound size or go in for extracted. But I have confidence in the collective wisdom of the B. B. K. A., and we are much indebted for their successful resistance to the pressure put upon them to appoint a size for distance-pins and broad shoulders; an excellent thing from a manufacturing point of view, but a thing greatly to be avoided by advancing bee-keepers.—E. H. BELLARS, *Wingfield, Christchurch*.

## CLARK SMOKER.

I have had a Clark smoker in use two years, and have found it very faulty indeed. Let anyone having a smoker of this type hold the furnace door next his face, work the bellows, and he will feel quite a blast of air coming through instead of going up the chimney. The construction is wrong altogether, as I shall prove; though the cold blast is a grand principle if properly applied.

The fire-box is too short and too wide, allowing the fuel to roll about getting out of the line of draught, and does not allow of keeping it alight long enough, and it cannot be filled from the top which is important. I have had one made which, though large, could be made smaller and yet give excellent results. The bellows are 12 inches long by 10 wide with a 10-inch barrel (or furnace) 3 inches diameter—the short tin pipe seen at top of bellows is  $\frac{3}{4}$  diameter. The blast is brought right up in the contracted chimney, which is 5 inches long by  $\frac{3}{4}$ , on the principle of a locomotive exhaust pipe forcing the blast to move upward through a  $\frac{3}{4}$  elbow pipe, creating a vacuum and a strong rush of air through the fuel. The top is easily lifted off to refill, it being a great advantage to put fresh material on that partly or nearly burnt, though the top might work on a hinge as made by an American firm. A spark guard might be fitted in the moveable top if desired. On lighting the fire I pour a little petroleum in the  $\frac{3}{4}$  hole at bottom. It lights instantly, and the smoker is no more trouble except to refill when needed. The large bellows give a long steady draught, which is just the thing in applying the match, instead of a series of short jerky puffs. I also have a direct draught at the lower end of barrel which can be instantly brought into use by moving a tin slide packed with asbestos (fire-resisting material), the latter is only a matter of fancy as the cold blast is perfection in itself. The above is not mere theory but good in practice, and is a perfect treat to use after being annoyed by an indifferent smoker. I have no interested motives in describing the above. Cannot some of our supply dealers give us a similar article and so benefit British bee-keepers?—J. C. LAMBERT, *South Island, Hull.*

## Echoes from the Hives.

*Leamington, Weston.*—Glorious change in the weather, bees working very hard on winter beans, turnip-seed, trefoil, &c. The scent among the hives and the roar of the bees on an evening tell very plainly that honey is coming rapidly in,—a very pleasing contrast to some of the last days of April and early part of the present month.—JOHN WALTON.

*Wisbech.*—This has been a good month for bee-keepers in this district. Like the preceding four months of the year very little rain, plenty of sunshine, our rainfall for the year to the present time (May 26th) only 4.58 in. This is a very large seed-growing district. Honey is coming in very plentiful. I put on a crate of twenty-one one-pound sections on the 11th, and to-day I see they are sealing the outside sections, so will be ready to come off (if this weather continues) by the end of the month. I also slung some honey out of bar-frame hive last Friday to prevent swarming. There have not been very many swarms here at present. Skeps were very light in the early spring.—J. D.

*Abingdon.*—My bees have done remarkably well this spring. I have taken off my first super, which is eight inches square; it was taken off on May 26th, it weighed eight pounds, and was quite full of sealed honey. I have six more, which are partly full, some will be ready to take off in a few days. I am working them on the

old straw skeps, which I prefer to any other hive; I have three in number, with three supers on each, which are all full of bees. The super is quite fit for a show.—D. BRUCKLAND.

*Bewdley, May 19th.*—The month of April has been most fatal to bees, the cold east winds and the sharp frosts have killed many bees, and destroyed many stocks. The last week, however, has done a great deal for those that have been cared for. The apple and broom being out, the bees have brought in both honey and pollen in fair quantities, some two or three stocks being up in supers. The first swarm that I have heard of was at Cheltenham on the 29th of April—a genuine swarm; the next, May 12th, at Redditch. On the same day I drove a swarm for a cottager from a hive 'hanging out,' which is apparently doing well; and several are showing signs of swarming very soon. Queenlessness has been also very prevalent in many places, particularly, of course, in the straw.—C. BROWN.

*Bedford, Cople, May 22.*—Since writing my last we have had some rough, cold weather, the end of April and beginning of May being very windy and cold, but on the 10th came the wished-for change, and with it the first swarm of the season in this district on Monday the 12th. Swarming seemed to be general all round. Bees are doing well now, I have one hive working nicely in super, there being plenty of winter beans, &c., in flower all round, but the fruit-blossom is minus, nearly all being spoilt by the late frosts; have driven one or two swarms where they hung out but refused to swarm.—A. F.

*Cumberland, Altonby, May 23.*—We have had wretched bee weather here this season so far, but it seems to be taking up now, and I hope we shall have a fine summer yet.—J. W.

*Essex, May 23rd.*—Dry weather, we are told, produces honey, my experience of the past two months leads me to think we can have too much dry weather for success in bee-keeping. In my locality we have had but two small showers since the middle of March, and during the past month severe frosts, the consequence is there has been little apple-blossom, and flowering shrubs have not developed themselves; in some cases the blossom of the sycamore has been cut off by frost. I think our season is about ten days late. Swarms as yet are not very general; I have had one from a supered stock; my hives were all supered on the 10th, a few only are at work, one crate has nearly all its sections ready for sealing. Our experts' report of his spring visits is very favourable both as to the increased number of colonies which he examined, and also to the satisfactory state in which he found them. I do not now look forward to having a prosperous season, as when the rain comes we may naturally expect a long continuance of it to equalise the long drought we have experienced.—G. H. A.

*South Cornwall, May 24.*—Though, no doubt, 'summer is incun in,' yet I can hardly report any summer weather up to date. True, we have had a week of hot sun by day, but the nights have been very cold, and on Monday, the 19th, there was frost here on the coast, and, as I am told, further inland on the following days. I therefore do not think the bees, with all their hard work, can have found much nectar. Last examination shows that several of my own hives, as well as some others in the district, are getting quite strong in bees. Yesterday I ventured to hang the first crate of sections, and to-day I have heard of a super set on a very strong Cottagers' bar-frame hive. If the wind should leave the east, a fortnight more of this weather would give great results, but then we have conflicting interests, and a 'shower is wanted' for various crops. I am sorry to report from further west a bad case of foul brood. A friend suggested that it was brought on by too much interference.—C. R. S.

*Sheffield.*—Bees just now are having a fine time of it:

the honey hangs in drops in the immense amount of sycamore flowers, or drops out, or crystallises in grains of sugar. It seems to be unable to ooze out from full-blown flowers, but comes out from the embryo bloom and from the leaves in little drops as well. I enclose you a specimen on which you will note the honey is quite ripe; and only wants 'lading' into the combs. Noticed bees coming home now, as they get what they require without having to 'wander from flower to flower.' You will be able to comprehend why I call the sycamore the 'king' of British honey flora. It lasts from three to six weeks, and for five years has always yielded more or less a crop, though, curiously enough, in the list of honey-producing plants given in the *Journal* some time ago—this the best of all was omitted. In my opinion no tree yields honey of such delicious flavour or in such abundance. JOHN HEWITT, *Sheffield, May 25.*

*Hants, Newmarket, May 26.*—We are having glorious weather, and swarming is going on rapidly, about three dozen having been recorded in this district. The first natural swarm in the neighbourhood was out of a straw skep in Mr. Jackson's house apiary at Earith, on Sunday, May 11th. It now covers nine frames, and is giving surplus honey in my apiary. Frames and sections are being rapidly filled. There is every appearance of a good honey year in this district. The weather is somewhat similar to that we experienced at the same time in 1882, and the honey yield is likely to be equally good though a little later.—C. N. WHITE.

*West Gloucestershire, 27th May.*—27th April to 8th May: weather very changeable and stormy. 9th to 27th May: beautiful warm weather, which the bees have taken advantage of. Drones appeared in my apiary on the 19th inst. Swarming will be late, the nights having been cold and frosty, and the atmosphere dry, which is not favourable for swarms. The first I have heard of in this district came off on the 22nd inst. Bees are now working well, filling sections and supers.—R. W. L.

*Wainfleet, May 27th.*—Last Saturday, when extracting turnip-seed honey in my ten farm garden, my foreman told me his neighbour had had two swarms, and was expecting a third. Presently he told me the third had just swarmed and flown away. Three swarms from three stocks in the middle of May is very good for this part of the country, as generally east winds make sad work with us. This year we are having a grand harvest from the clove and turnip-seed. I extracted about 50 lbs. from four hives, thirty-six of which have gone to the Health Exhibition. In the ten I have never had such strong hives, but at home they are almost a failure, although the latter have had all the attention they could possibly want. The chief cause is from having no shelter, the result being three have blown over, besides two being queenless. The weather is now very good, although the frosty nights are making the turnip-seed go out of flower quickly; but beans and mustard will soon be in.—W. M., *Wainfleet.*

## Queries and Replies.

QUERY No. 773.—(A NOVEMBER.) *Cutting out Queen-cells.*—On Saturday, the 10th of this month, I examined my bees, which have been fed up on candy all the winter, and found them (one hive especially) in very good order. This one had plenty of young bees, also brood and some queen-cells, all of which I cut out, as my desire is to check swarming and have as much honey as possible. On Tuesday, the 20th, there issued from the hive I speak of what looked like a swarm, which, after some excited wheeling in the air, settled upon its own hive. At one time there were three clusters underneath

the porch and underneath the alighting-board; these gradually massed into one cluster, and after about three hours they returned by degrees into their own hive. I then examined the frames, and found three queen-cells fully formed and closed, and several others incomplete, all having either grubs or formed bees in them, all of which I cut out. I wish to know what was the cause of this large number of bees leaving the hive in this way? should it be prevented again happening? and how? There was a waste of three hours' time and much energy, which I suppose should not be allowed. They certainly could not have had a second queen in the hive; and as they had three frames given them ten days before, which on the day I speak of were worked out, nothing more, they cannot have been over-crowded. I am quite a novice in bee-keeping, and shall be very glad of information. I have been a subscriber to *B. B. Journal* for nearly two years, but do not remember to have seen a circumstance similar to that which I write about noticed. 1. In the first instance you committed an error in cutting out the queen-cells on the 10th, but you committed a much greater in cutting out those on the 20th. Cutting out queen-cells will never check the swarming impulse. It is much better to let nature take her course. Read the article 'Swarms Deserving' under the heading 'Useful Hints,' in our present issue, and in future act upon it. Immediately after cutting out the cells on the 10th, the bees formed new ones. These would be sealed over by the 20th, and the swarm would naturally issue on that day, which, as appears, was the case. The bees would have swarmed some days earlier if the former cells had not been removed. When the swarm at last came out on the 20th, the queen, from her ovaries being full of eggs, fell to the ground, and was in the midst of the clusters of bees under the alighting-board unable to rise, and no doubt perished there when deserted by the bees. Your hive is now queenless, and queen-cells are again raised; a young queen will issue in due time, but before she begins to perform her duties of maternity the population of the hive will have greatly decreased. *Experimenta doct.*

QUERY No. 774.—(JAMAICA.) 1. *A Jamaican Bee.*—May I ask you to acquaint me with the name and species to which the bee forwarded herewith belongs? Judging from the numbers that are daily to be seen, I should say they were indigenous. I have never heard of any being domesticated, and, although I have shown the specimen to many, I have hitherto been unable to get any information about them. I, at first, mistook them for Ligurian drones, but was soon undeceived on endeavouring to capture one, by its applying its sting in a most vigorous and painful manner. 2. The bee forwarded is indigenous to Jamaica. Its specific name is *Centris fasciata*, Fabr. The male is rather smaller than the female. 3. *Honey Vinegar.*—Can you also let me know of any simple process by which vinegar may be produced from honey? The natives here manufacture it, but their method appears to me to be both extravagant and ineffective, as the vinegar produced is of a very poor quality. 4. Take thirty gallons of rain-water; heat it, and put it into a barrel; add two quarts of whisky, three pounds of honey, five cents worth of citric acid, and a little mother of vinegar. Fasten up the barrel, and put it in the cellar, and in a short time it will contain vinegar unsurpassed for purity and excellence of taste.

QUERY No. 775.—(WILD BEES.)—*Indian Bees.*—1. Can any correspondent give me information as to domesticating wild bees? A friend of mine, a resident in the Naga Hills in India, has tried to do so, but without success.—2. There are many native Indian bees which are susceptible of domestication. There are others which, as an Indian Commissioner writes, 'would require all the taming powers of a Sir John Lubbock to reclaim.' In the Kutchha Naga country forming the

western portion of the Naga Hills district, there is so far an approach to domestication that the wild bees and their hives are looked upon as the property of the nearest village in whose neighbourhood they have settled, and in that place much honey is gathered. Mr. Stormont, Superintendent of the Model Farm, Pachora, records his experience in endeavouring to domesticate some of the vagrant colonies found suspended on their single comb from the branch of a tree:—Owing, however, to the violent temper of these wild bees not allowing even at swarming time their queen to be handled, my attempts at living were persistently ineffectual, until about three years ago, when I accidentally discovered that an irritated swarm when syringed with water immediately settled and commenced to devour their honey, and that when sprinkled with sweetened water they gorged themselves with the liquid and became sufficiently good-tempered to admit of considerable liberty being taken with them. By this means I at last succeeded in getting a swarm safely into a box hive along with a piece of comb which they had already constructed. After a little confinement they seemed to have made up their mind to settle, and went quietly to work; some time after, however, they disappeared all of a sudden, leaving behind them a single piece of comb large enough to testify that they had been fairly industrious during their stay.' It is only by patience and study of the habits of these bees that success can eventually be achieved. The introduction of Mr. Cowan's *Guide-book* and of English made hives would prove of the greatest service to all who desire to improve apiculture in India. 2. *Honey not crystallising*.—Can any one explain why in India honey does not become solid? The temperature is often very low, but the honey remains liquid.—I. We can only suppose that the heat of the Indian climate prevents the granulation of honey. In the colder parts of the country—as the higher parts of the Himalaya mountains—honey will granulate without doubt. Nevertheless the nectar yielded by tropical plants may have less tendency to granulate, even when removed to a colder climate.

#### NOTICES TO CORRESPONDENTS & INQUIRERS.

W. CORNER.—The bee forwarded belongs to the class called *Andrenide*. The *Andrenide* is a section of the great family of *Apidæ*. The specific name of the bee is *Andrena Trimmeriana*. It is a burrowing bee. The cells it forms for its young are beautiful specimens of insect architecture. They are wonderfully neat and perfect. They are thumb-shaped, made from particles of sand, fixed together by some viscid fluid which the bees have the power to secrete. The outside of the cell is roughish; the inside quite smooth. If you had taken the trouble to dig where you saw the bees enter, you would no doubt have come across these cells. You would have found in them a small pellet of slightly sweetened pollen about the size of a red currant, just sufficient for the sustenance of the infant bee. These bees would not in any way consort with your hive-bees. There are numerous points of difference which cannot be obliterated. In habits they are different. They are solitary-living bees. They are male and female; no neuters. They do not make provision for the winter. Physiologically, too, they differ. Their tongue is broader and shorter, and they are not aculeated. With the exception of the exterior form, there is little similarity between them and hive bees.

C. T. CHEVALIER.—1. *Bees deserting the Hives*.—The reason was probably starvation. 2. *Bees looking Old*.—As there was brood on April 8th, that would now be hatched, consequently they cannot all be old. 3. *Fertile Workers*.—They cannot be distinguished from ordinary workers and bear no resemblance to queens.

ONE WHO DOES NOT KNOW IT ALL.—*Bees refusing Syrup*.—They would not do so unless their instinct told them it was unwholesome. Perhaps you made some mistake in the proportion of salicylic acid, or the sugar was bad, or the water, or you burnt it. 2. *Visits of Experts*.—You do not give your address, consequently we do not know your county; but surely your county secretary could and would put you in communication with some experienced member who would assist you even if your Association had no regular expert.

R. E. C.—1. *Fermenting Food*.—Food prepared from unrefined sugar is very apt to ferment in hot weather as it contains the elements of fermentation, hence the importance of using only the best refined crystal sugar. Fermented food is certainly highly injurious to bees. 'Hints: Had you read carefully you would not have been feeding on 12th of May if the weather with you was as fine as in London. We wrote at the end of April, and said, 'Feeding must be continued while the weather remains at present,' i.e., bitterly cold. 2. *Flying Foundation*.—It is quite immaterial. 3. *Spreading Brood*.—When the hive is so crowded with bees as to contain brood outside of the end frames, it is high time more room is given by supering or by adding comb or sheets of foundation in the middle.

T. PRENTICE.—*Spring Decadling*.—The refuse wax is simply the cappings of the cells, and is not caused by wax-moths. Your bees have suffered from spring dwindling during these prevalent easterly winds. If, as you say, the queens are very prolific, do not unite the colonies. Perhaps you have over-manipulated in cold weather, and thus chilled the brood. Contract the hive, in each case, to as many combs as the bees can cover, and introduce extra combs of worker-cells as required. You may thus build up both colonies into strong stocks for wintering, and possibly obtain some surplus honey by extracting.

ROBERT DOUGLAS.—*Transparent Hives*.—We are unacquainted with the hive you mention, but if by 'transparent' you mean that the hive has glass sides, we should object to it *in toto*, since bees cannot winter well in glass. Any kind of hive can be placed under your 'shed,' but we prefer hives on separate stands. You cannot do better than to act on the advice given in *Moderate Bee-keeping*. You should read also the *British Bee Journal*.

G. SANDS.—*Section Racks*.—There are no racks made to hold sections of two sizes to our knowledge, nor is it desirable. The size of the 1-lb. section in most common use is  $4\frac{1}{2}$  in.  $\times$   $4\frac{1}{2}$  in., and this size may be used in the Standard frame, six sections filling the frame; but the  $4\frac{1}{2}$  in.  $\times$  4 in. fits the frame better. A sub-committee, to report on Standard sections of 1 lb. and 2 lbs., has been appointed, and it is probable, we should think, that the last-named size, as a standard for 1 lb., may be adopted. All hive-makers supply both sizes, we believe.

J. E. ROSMAN.—The honey market is not open for the disposal of honey from the colonies. The aims of the B.B.K.A. in this direction are solely for stimulating the production and disposal of English honey.

SUFFOLK.—*Fastening Foundation in Sections*.—The section is placed upon a table or bench, the foundation laid on, a wooden gauge laid upon it, and a roller, having been dipped in some thin starch paste to prevent it sticking to the wax, is run along with a considerable amount of pressure. The wood should be quite dry. The foundation is turned up at right angles to the gauge. There are other ways, by dipping the edge of the foundation in melted glue, and inserting it into the slit sawn for the purpose; also by the use of a wax-smelter and block. (See Useful Hints.)

LEICESTERSHIRE.—Please refer to reply to 'D. T. Morgan.' The Secretary of the Leicestershire B.K.A. is Mr. E. Ball, Waltham, Melton Mowbray.



**D. T. MORGAN.**—*Beginning Bee-keeping.*—Adopt bar-frame hives. Borrow a hive for a model, and endeavour to make the hives you require like it. Purchase a swarm of bees. Study *Modern Bee-keeping* and *Conant's Guide-book*, and read the *Bee Journal*. Place yourselves in communication with the secretary of your County Association; and if it has an expert solicit the favour of his visits.

**J. WILLIAMSON.**—*Queen depositing more than one egg in a cell.*—A young and healthy queen should deposit the eggs regularly in cells. Sometimes a queen will lay several eggs in one cell and pass over others when she ascertains that they are not ready for the reception of the eggs; or it might arise from some congestion of the ovary. The workers are able to transfer the superfluous eggs from one cell to another, as only one would be allowed to hatch.

**J. COTTELL.** *Maberna.*—1. The idea of keeping bees closed for three months in a public exhibition is one which should not be entertained and which we should be pleased if you would not attempt. It is contrary to nature and humanity, and would be fraught with the direst consequences. 2. Presuming that bees could be kept for that time, the best food would be either honey or syrup of a consistency similar to that of the honey to be gathered at that season. 3. The bees should be conveyed the distance mentioned in a travelling hive, and in the evening of the day of arrival placed in the observatory hive.

**S. V.**—1. The pollen in the piece of comb forwarded is such as might be gathered from the bean-field in your neighbourhood. 2. The bee received is a female wild bee; its specific name is *Andrena fulva*. A description of which may be found in Vol. XI., p. 35.

**W. REDSHAW.**—*Wild Bee.* The bee forwarded is one of the prettiest of our little wild bees. The name given to it by naturalists is *Epeolus*.

**ANON.** *Chilled Brood.* The comb forwarded betrays no signs of foul brood. It was a slight case of chilled brood. The precautions you have taken will effectually prevent any evil results.

**SUPERIOR BEE VEILS.** Wire Gauze Fronts. 1s. each, three for 2s. 9d., post free. Address Wm. CLARK, Halstead. 2025

**BEE HIVES and APPLIANCES**

Of the best quality, at the lowest possible price, to be obtained from

**JOHN LEAKE, JUN.**  
BEACON STREET, LICHFIELD.

**COTTAGERS' HIVE,** made of 1 inch best Pine, planed outside, contains 9 Standard Frames and Dummy, resting on Tin Runners, suitable for Bee-Shed. Price 6s.

**ABBOTT'S HONEY EXTRACTOR,** best make, 9s. 6d.

**BINGHAM SMOKER,** neatly and strongly made, 3s. 6d.

Other Appliances at an equally low rate. 5 per cent. discount off all Orders up to April 1st.

Send Card for PRICE LIST to

**J. LEAKE, Jun.,** Beacon Street, Lichfield. 1974

**WIRE STAPLES, &c.**

**A. GOODALL & SONS,** BRIGHOUSE, YORKSHIRE.

Or from

**C. T. OVERTON,** THREE BRIDGES, SUSSEX. 1963

**PURE FOUNDATION.**

Owing to rapid rise in the price of Beeswax, I now quote 2d. per lb. advance on list prices. Present price, 2s. 2d. per lb.; 5 lbs. for 10s.

**COMBINATION HIVE,**

24 inches long, ten broad-shouldered Frames, deep Supering, Roof, &c. Price 8s. (The cheapest hive made.)

**REAL AMERICAN SECTIONS,**

1s. per 100.

**PRIZE STRAW HIVES,**

1s. 4d. and 1s. 6d.

CATALOGUE POST FREE ANYWHERE.

**G. STOTHARD,** Mill Apiary, Welwyn, Herts. (2453)

From M. J. J. carded for Straw Slaps at the Great Crystal Palace Show, 1875.

Seventeenth Edition. Price One Shilling.

**SEVENTY POUNDS A-YEAR:**

HOW I MAKE IT BY MY BEES.

By the late J. W. PAGES.

Also, by the same Author, price Sixpence.

**EARLY ARTIFICIAL BEE-SWARMING.**

No watching required.

Apply to Mrs. J. W. PAGES, The Chestnuts, Alfriston, Sussex, by whom the same manufacturers of 'Economic Bee Furniture' are employed as formerly. (10)

**METAL ENDS FOR FRAMES.**

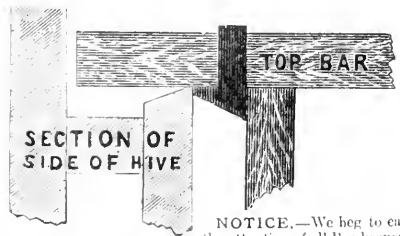

**NOTICE.**—We beg to call the attention of all Bee-keepers to our latest improvement in METAL ENDS for Frames, which entirely supersede the use of Zinc Runners and Broad-shouldered Frames, while their weight and fixing keep the Frames perfectly perpendicular. Price 10d. per doz., 9s. per gross. Specimen sent on receipt of two stamps.

All Hives above 10s. each are fitted with these Ends.

Illustrated Catalogue free on application.

Silver Medal, Knight-bridge, 1883. First and Second Prizes at Hayley, Coventry, &c.

**C. G. HARRISON & CO.,**

Hive Makers and Dealers in all Apiarian Appliances,

HALESOWEN, WORCESTERSHIRE. 2155

**J. DINES & SON,** Manufacturers of Bee Appliances, System, and Extractors, Medford, Essex.

**W.P. MEADOWS,** Wholesale & Retail of Bee Appliances.

**The Rayner Fooder** Perf. For description see Journal May 19<sup>th</sup> '84

**DR. PINE'S**  
**Registered Removable Metal Frame Ends.**

Prize Medal, B.B.K.A., 1882; and numerous other Prizes.

BY the use of this valuable invention the making of Frames is simplified. No metal runners are required, all systems of frames are rendered interchangeable, and propolization is reduced to a minimum.

Unfortunately, as is the case with all inventions of merit, numerous substitutes are being introduced under the name of 'improvements.' But there is not one of these so-called 'improvements' which does not possess defects from which the original invention is free.

It is, therefore, absolutely necessary when ordering Hives to specify that the Frames are to be fitted with 'DR. PINE'S ENDS,' and with no others. All Hive-makers will supply Hives fitted with them, and generally without extra charge, the small cost being sayed in diminished cost of labour.

Price of the Ends, 1s. per doz. or 10s. per gross.

**DR. PINE'S**  
**Woven Wire Veils.**

Prize Medal, B.B.K.A., 1879.

Do not confine the breath, do not obstruct the sight, and cannot be blown against the face or cars.

Price 2s. 6d. each.



**DR. PINE'S BEE-KEEPERS' LOTION**

Is the acknowledged Remedy for Stings, especially for removing the subsequent inflammation. Price 1s. 6d per bottle.

The above Inventions may be obtained from

Messrs. NEIGHBOUR & SONS, Regent St. & Holborn, London; And from all respectable Dealers in Bee-keepers' Requisites.

Dealers may obtain Wholesale Prices from the Inventor,

Mr. F. LYON, 94 Harleyford Road, London, S.E.

**BEE VEILS.** Improved with Wire Gauze Fronts, or with Silk Brussels Net. Post free 18 Stamps. Address E. DING, Papworth-Everard, St. Ives, Hunts. (5d)

**CLANE (PREPARED)** for making Straw Skeps. 1 lb. postal packages—Fine, 2s. 3d.; Coarse, 1s. 3d.—free. **SALICYLIC ACID**, 1s. per oz. post free. **THYMOL**, 1s. packets free. Either of the foregoing cheaper in quantity. Address J. R. W. HOLE, Tarrington, Ledbury.

**DALLINGHOOD.**

**ANDREW BLAKE**, in tendering his best thanks to all those who have kindly given him their patronage for over Three years, begs to inform them that on account of his other branches of trade, and for convenience of the Hive business, he has made this over to his Son, who has been accustomed to the work, and will carry on the business at Ipswich upon the same principles as before, and he would solicit for his Son the same kind favour which has been given to himself. For the future, Letters for Hives, &c., should be addressed to—

Mr. JAMES BLAKE,

BEH-HIVE MANUFACTORY,

Cemetery Road, Ipswich, Suffolk.

PRICE LIST ON APPLICATION. 2032

**THOMAS B. BLOW,**  
**WELWYN, HERTS.**

Manufacturer of Bee-keeping Appliances of every Description,

And IMPORTER OF FOREIGN BEES,

**BEGS** to call attention to the unrivalled quality of his productions. By the aid of special power machinery he is enabled to combine moderate prices with high quality. Mere lowness of price is not so much aimed at as accurate fit and finish, all goods being adapted both for the convenience of the Bees and ease of manipulation to the Bee-keeper.

ILLUSTRATED CATALOGUE, 48 Pages, 50 Illustrations, full of interesting and useful information, Free on application.

**THE HEREFORDSHIRE**  
**SCHOOL OF APICULTURE**

**SUPPLY BEES, HIVES,** and everything pertaining to Modern Bee-culture. Hives made only of the best well-seasoned wood, a quantity of which is always kept ready cut and prepared for putting together.

Awarded Honourable Mention for a HIVE exhibited at COLK INDUSTRIAL EXHIBITION, 1883, and First Prizes at various County Shows. Revised Catalogue for 1884.

**J. R. W. HOLE,**

(Expert to the Herefordshire B. K. A., qualified by B. E. K. A. Certificate.)

Address—TARRINGTON, LEDBURY.

**CHARLES T. OVERTON,**

First Class Export of the Sussex Bee-keepers' Association,

**THREE BRIDGES, SUSSEX,**

Begs to call attention of all Bee-keepers to his **NEW STOCK OF BEE-KEEPING APPLIANCES** for 1884, and hopes to be favoured with their support.

Sales and Repairing of Bees, and other Appliances, warranted at Lowest Rates, Knightsbridge, Hastings, and other Shows, for the Best Bee Hives, Bees, Smokers, Supers, Extractors, Comb Foundations, &c.

Orders can now be booked for Prime Stocks, and Swarms, of ENGLISH, LIGURIAN and other Foreign BEES, for early spring delivery; also Imported LIGURIAN QUEENS. First consignment will arrive early in May.

**SPECIALITIES.**

The 'COWAN HIVE,' and Extractors, English Smokers, the best in use; Supers; Honey Rack; Comb Foundation, American 2-lb. and 1-lb. Sections; FLAT TOP STRAW HIVES, with hole in top for feeding and supping, 2s. each; Crates of 18 1-lb. Sections for Straw Hives, 5s. each, complete.

Questions on Bees and their Management answered by return of post, 3d. stamps. Send 7d. for Models of Bee-keeping, 1s. 3d. for British Bee-keepers' Guide. Catalogue free on application.

**E. G. PARKER,**

WATCHMAKER & JEWELLER,

**ALTRINCHAM, KNUTSFORD, and WARRINGTON.**

**All kinds of Bees, Bee-Hives, & Appliances,**

For Old-fashioned as well as Modern Bee-keeping.

**BAR-FRAME HIVES** from 4/6 each, **COMB FOUNDATION, SMOKERS, FEEDERS, &c.**, at most reasonable prices.

Winner of 15 Prizes & Medals for Bees & Appliances last year.

1st Prize for English Bees, both in 1882 and 1883.

1st Prize for Observatory Hive.

1st Prize for Best and Cheapest Cottagers' Hive, on the Movable Comb principle, not exceeding 15/.

1st Prize and Silver Medal for Best and largest Collection of Bee-Hives and Appliances for Modern Bee-keeping, including a Hive complete on the Modern System at 25/-, at the Cheshire County Bee-keepers' Association Show; also 1st Prize for largest Collection in 1882.

'MODERN BEE-KEEPING,' the Simplest and Cheapest Book. Price 6d.

Cash with Order to be sent to Altrincham. (61)

# THE BRITISH BEE JOURNAL

Communications to the Editor to be addressed 'STRANGEWAYS' PRINTING OFFICE, Tower Street, St. Martin's Lane, W.C.'

[No. 148. VOL. XII.]

JUNE 15, 1881.

[PUBLISHED FORTNIGHTLY.]

## Editorial, Notices, &c.

### CONFERENCE AT THE INTERNATIONAL HEALTH EXHIBITION.

Members of the British Bee-keepers' Association and of all affiliated County Associations who wish to obtain tickets of invitation from the Council of the International Health Exhibition to attend the Conference of British and Foreign Bee-keepers on Friday and Saturday, July 25th and 26th, are requested to send in their names and addresses as early as possible to Mr. John Huckle, Secretary British Bee-keepers' Association, Kings Langley, Herts, who will forward them to the Secretary of the Literary Department of the International Health Exhibition. The number which the hall will hold being somewhat short of 400, the number of invitations must be limited.

### HOGES' HONEY.

We cannot find much sympathy for Mr. Hoge, the American speculator in honey, under the disappointment which he must experience at not being allowed to exhibit his 'prepared' honey in close proximity to the department assigned by the Council of the International Health Exhibition to the British Bee-keepers' Association. We are not curious to inquire as to the means by which Mr. Hoge gained admission to this department at all, but there can be but one opinion as to the want of good taste displayed by Mr. Hoge in endeavouring to attract the notice of the public by planting his exhibits in close proximity with those of the B. B. K. A., with which he has no connexion at all. It was open to Mr. Hoge as an American to exhibit in the Foreign Department, or by becoming a member of the British Bee-keepers' Association to exhibit under their auspices, and subject to their conditions; but instead of adopting either of these courses, he has tried the more hazardous one of trying to make a cat's paw of the B. B. K. A. in order to get his chestnuts out of the fire, and must not be surprised if he gets a scratch from the paw of the cat for his pains.

We understand that the specimens of adulterated honey exhibited by Mr. Otto Helmer and

Mr. Cowan were for a few days removed by an Order of the General Superintendent of the International Health Exhibition in deference to Mr. Hoge's wishes.

These exhibits have now been restored to their former position, and we fear that Mr. Hoge will still have to gaze upon the case of specimens amongst which will be found some samples of his honey condemned by Mr. Otto Helmer in the *Analyst* of last April, as will be seen by reference to page 139 of present volume of *British Bee Journal*.

### SPURIOUS HONEY.

We extract from the *American Bee Journal* the following letter from Messrs. Stearns and Smith, honey-dealers in San Francisco, who with regard to spurious California honey propose the following remedy:—

"Through the widely circulated *American Bee Journal*, we desire to call the attention of our Pacific Coast honey producers, and especially those of California, to the urgent and immediate necessity of a law or laws against the adulteration of honey, and the sale of the same. Our dairymen have met and discussed the matter of adulteration, and our State Legislature has enacted a law protecting them against the sale of "bull butter," or oleomargarine, and we hope our different Bee Associations will take this matter up. California honey has a world-wide reputation for purity and excellence. There is for sale on the market a vile compound, under fancy labels named "honey," composed of about 40 per cent of honey, 50 per cent of glucose, and 10 of water. It is a lard on our industrious bees; it works a great hardship to their owners; and, when it is shipped to other places, it gives our fine honey a bad name, and there lies the great damage to our honey producers. We hope they will talk this matter up, and send men to the next State Legislature that will look to their interest and protect by law this great industry of California."

### TO COUNTY ASSOCIATIONS.

The British Bee-keepers' Association, in arranging for the decoration of the Bee Department at the International Health Exhibition, have prepared a design for shields to be used for trophies of small flags suitable both for indoor and outdoor decoration. These can be supplied to County Affiliated Associations at 6d. each, post free; they can also be made up on wood, ready for trophies of three or five flags at 1s. 6d.

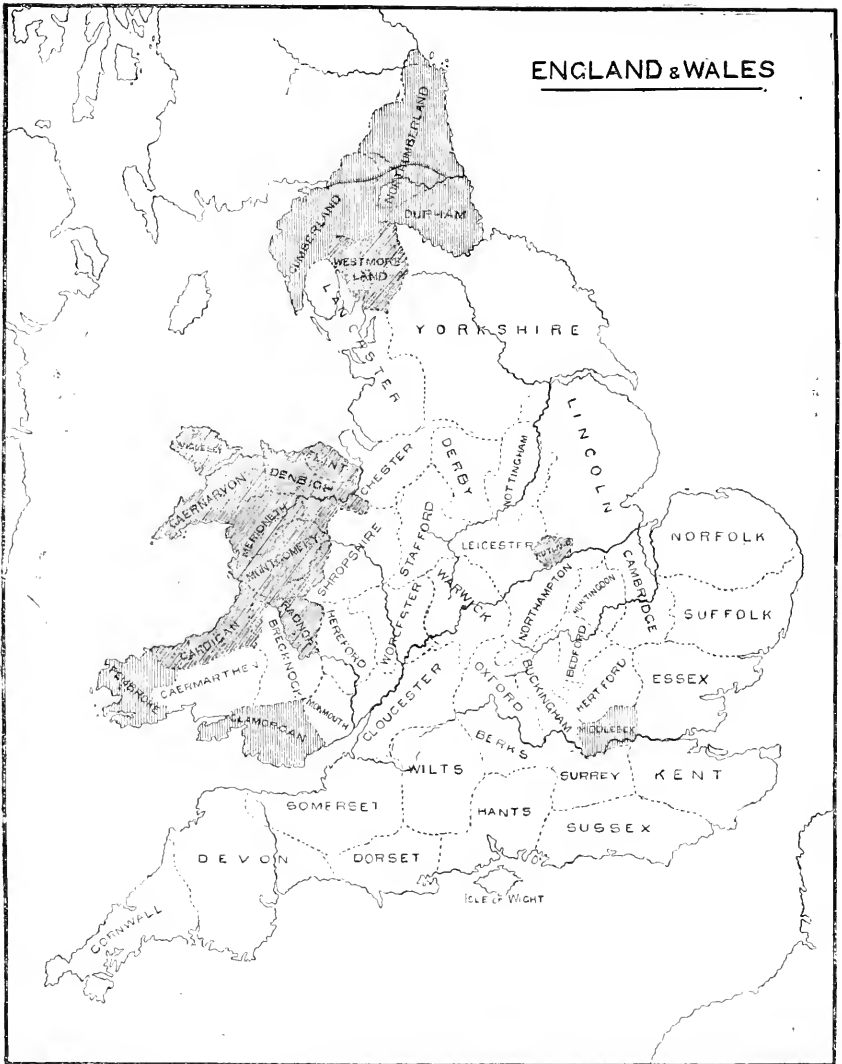

MAP OF ENGLAND AND WALES:

SHOWING THE COUNTIES AFFILIATED AND NON-AFFILIATED WITH THE BRITISH BEE-KEEPERS' ASSOCIATION.

In order to make our readers sensible of the work which the B.B.K.A. has been effecting during the last six years, we publish the above map of England and Wales, which shows in a clear manner the affiliated Associations of the Parent Society. The map indicates (1, unshaded) the counties which

possess completely formed Associations; (2, light-shaded) those in which Associations are partially formed; and (3, dark-shaded) those still benighted counties into which the light emanating from the central body has not yet penetrated; but even in some of these last a movement has been made

which will soon bring them within the inner circle of our system. It will be seen that there are now thirty-seven counties affiliated with the B. B. K. A., and we may reckon that there are 6000 members of these Associations. Many of these Associations are worked by the aid of district secretaries in the various large cities in the counties; and these again have local advisers in various districts, so that soon the ramifications of the Society will reach the smallest village and hamlet in the kingdom.

We have good hope that in the course of the coming year a similar map may appear in the *Journal* disfigured by no black patches, to be followed by equally satisfactory maps of Scotland and Ireland; so that at no great distance of time we may have the satisfaction of presenting our readers with a map of the whole United Kingdom covered with Bee-keepers' Associations. One result of such a desired consummation would be that it would give us the pleasure of being able to publish the rules and regulations of some future Bligh Competition established under a confederation of the Parent Associations of England and Wales, Scotland, and Ireland, from which no bee-keeper in this realm will have to be excluded.

In the present number of the *Journal* a circular setting forth the objects and the origin of the Peel Testimonial Fund will be found inserted. The map appears very opportunely with this circular, as it shows in a visible form the extent of the effect of the energy and tenacity of purpose displayed by Mr. Peel in bringing bee-keeping to the advanced position it at present occupies in the United Kingdom.

#### INTERNATIONAL HEALTH EXHIBITION:

##### BEE DEPARTMENT.

We are informed by Mr. A. G. Dawson that we were in error in ascribing to him the exhibit of the lantern-slides illustrating the various phases of bee-life. The honour of their exhibition is due to Mr. A. Watkins, Wilcroft, Hereford; and we desire to direct the attention of our readers to a letter by that gentleman on the educational value of such illustrations, and of his readiness to give any assistance in his power to the Committee of the B. B. K. A., if they think it desirable to issue under their auspices a series of slides suitable for lectures on bee-keeping.

An excellent exhibit of Honey as Medicine, for relieving coughs, colds, asthma, &c., has been added to the department by Mr. Cardwell, Chemist, of Reading.

An ingenious specimen of a natural swarm of bees has been prepared by Messrs. Abbott Bros. of Southall, and has been attached to the tree which adorns the Bee Department.

#### EASTERN AND OTHER BEES FOR NEW ZEALAND.

We are informed that Mr. T. B. Blow, of Welwyn, Herts, has a commission to forward Syrian, Cyprian, Holy Land, Carniolan, and Italian bees to New Zealand. It will be very interesting to ascertain how these bees, on which there are so many

diverse opinions in this country, succeed in their new location.

#### HERTFORDSHIRE ASSOCIATION.

The Prize List for the Annual Exhibitions to be held at Hitchin on July 9, and at Watford on July 23, is to hand. The prizes offered are chiefly for artisans and cottagers; in these classes the amounts offered have been considerably increased, whilst those in the amateur classes have been reduced; medals only being offered in these classes. A class for hives and appliances is open to all England. The schedule contains a notice that the Association is prepared to arrange for the examination of third-class candidates at both of these shows in accordance with the scheme recently arranged by the British Bee-keepers' Association.

It is proposed for the future that when the number of members in any parish reaches six, a copy of the *British Bee Journal* shall be circulated in that parish alone, and that after circulation it may be retained for the use of the members residing in that parish; the members to decide in whose custody it shall remain. The necessary arrangements for carrying out this proposal have been made by the Rev. G. V. Oddie for Aston parish, and by Mr. W. M. Allfrey for North Mymsnas parish. In the former parish the number of members is sufficiently large to necessitate the circulation of two copies. The hon. secretary hopes that the several District Secretaries, Local Advisers, and the members generally, will complete such an arrangement as early as possible, in order that each parish in the county may have its standing bee-keeper's library.

#### CALEDONIAN APIARIAN SOCIETY.

The eleventh show of honey, hives, and bees, of the above Society, will be held at Edinburgh, in connexion with the Highland and Agricultural Show on the 23rd, 24th, and 25th July. We beg to acknowledge the receipt of the schedule of this show. The show is being held under most distinguished patronage. The Prizes offered are ample and complete. We trust that the exertions of the painstaking secretary, Mr. R. J. Bennett of Glasgow, assisted by the practical experience of the well-known bee-keepers who form the Committee, may be crowned with success; that it will form a creditable and interesting addition to the show of the Society under whose auspices it is held; and that the bee-keeping fraternity of the North will unite together in its support.

#### NOTTINGHAM BEE-KEEPERS' ASSOCIATION.

The Rev. A. H. Halley, hon. sec. of the Nottingham B. K. A., having accepted the curacy of St. James's, Upper Edmonton, has in consequence been obliged to relinquish the hon. secretaryship. The Rev. T. F. Boulbee, St. Mark's Vicarage, Nottingham, we are pleased to be able to report, has consented to supply Mr. Halley's place as hon. secretary. Mr. Halley, though no longer a resident in Nottingham, has been elected as the London

representative of Notts, in accordance with the suggestion made at the last Quarterly Meeting, but which has not yet been finally resolved upon.

Mr. Halley having now come to reside in Middlesex will, we have no doubt, prove a valuable accession to the Association now forming in Middlesex.

#### IRISH BEE-KEEPERS' ASSOCIATION.

Following the example of the leading Agricultural Societies of England, the Royal Agricultural Society of Ireland has arranged for the attendance of the bee-tent and lecturer at their Annual Exhibition to be held at Kilkenny on July 2nd, 3rd, and 4th. See advertisement.

#### TREATMENT OF FOUL BROOD.

Mr. Cheshire has, we understand, made some most successful experiments in attacking foul brood; and he expresses his willingness to treat an infected hive under the eye of the Committee, in order that some consensus of opinion may be presented to the International Congress. The plan involves scarcely any labour, and no destruction of combs or hive, and would not cost more than 3d. per stock. If this be verified, it is good news for bee-keepers, and we trust the Committee may give Mr. Cheshire the opportunity he desires.

### ASSOCIATIONS.

#### BRITISH BEE-KEEPERS' ASSOCIATION.

The second Quarterly Meeting of the above Association took place on Wednesday, the 16th May, at 6 p.m., in the Board-room of the Royal Society for the Prevention of Cruelty to Animals, where a large audience had assembled to hear an address by Mr. F. R. Cheshire on the subject of 'Honey as Food.'

The Rev. C. E. G. Jenyns having taken the chair, said that he would only interpose for two or three minutes between the audience and Mr. Cheshire, whose remarks he knew would be highly interesting to all present. He need not enlarge on the importance of the subject to be treated that night. He thought that it derived additional weight just now in view of the approaching Health Exhibition, at which the British Bee-keepers' Association had secured a most favourable site for the display of honey, bee-keeping apparatus, literature, etc., which he trusted would be the means of educating thousands of visitors to the Exhibition in a subject comparatively little known or understood. The lecturer needed no introduction. He was well known to them, and they might safely trust his competency to deal with the subject he had undertaken.

#### HONEY AS FOOD.

Mr. President, Ladies, and Gentlemen,\*—The subject which I have the honour of introducing to your notice on the present occasion is not one of my own selecting, but has been pressed upon me somewhat hurriedly by your Committee, who have failed in securing the services of a medical practitioner, who was to have read a

\* In a previous number of the *Bee Journal*, I cast my lecture into a form to meet the general public, who ignorant of apiculture would not have been able to follow at all closely the argument involved in the lecture as now presented. The former is intended for general distribution at the Health Exhibition. The lecture as delivered at Jernyn Street, was illustrated by experiments, reference to which would rather hinder than help the general reader, and in consequence all allusion to them is here omitted.—F. C.

paper on honey as food. I throw myself, therefore, into the breach, hoping that you will supplement during the discussion any omission that may present itself to your notice. Several with us are well able to enter into this question upon its scientific bearings, and I am pleased to see in our midst an eminent chemist who has more than once shed light upon a kindred subject, and in similar gatherings to the one now before me.

Mr. Hehner's recent lucid and exhaustive lectures upon the 'Chemistry of the Hive' have well shown the fact that honey is largely, indeed almost wholly, made up of two kinds of sugar with a certain proportion of water. One of these sugars has the power of turning the plane of polarisation to the right, the other to the left; and they are in consequence respectively denominated dextrose and levulose. The proportions of these sugars are pretty constant, but I am not of opinion that they are so absolutely so as some have stated, for reasons which I must adduce later on. Since these sugars form the food constituents of honey it will now be necessary to consider their value in that relation, and so I purpose pointing out the use of nectar to flowers, and then the physiological, *i.e.*, the food uses of honey (as the immediate outcome of gathered nectar) to bees and to mankind.

First, the use of nectar to flowers. The fertilisation of ordinary flowering plants is brought about by the transfer of pollen grains formed in the anthers to a sticky surface denominated the stigma. Each pollen grain then throws out from its side a tubiform extension, frequently of very considerable length (in many British lilies 3 or 4 in.), which extension grows on and on through the central organ of the flower till reaching the ovule it becomes the channel by which the contents of the pollen grain are transferred to the embryonal cell, and the fusion of the two (the anther cell and embryonal cell) becomes the beginning of the new individual in the seed. Without this fusion or fertilisation the object of the bloom cannot be accomplished, whilst the structure of the flower very generally is such that failing the intervention of insects the transfer of pollen to stigma is exceedingly improbable, and even impossible. The flower, therefore, baits itself, so to speak, with nectar, for wherever pollination is effected by insects, glandular organs are formed in the flowers which secrete sugary and odoriferous juices, or else these juices are contained within delicate cellular tissue, from which they are easily sucked out, as is the case with many of the orchids.

The position of these glandular organs or nectaries is extremely varied, but it always stands in some relation to the special contrivances adopted by the flower to secure its pollination through insect visits; while at the same time it is almost invariably so protected that rain shall not easily wash away the sweet secretion. In the buttercup, for example, although the nectaries are placed upon the petals of the corolla, the honey is secure against rain, as it is covered by a tiny lappet, which very persistently refuses contact with water. In the common pansy the inferior petals are rolled up so as to form the spur behind the flower, and into this spur nectar is secreted by two appendages of the anthers provided for the purpose, while a wonderfully beautiful arrangement exists to secure fertilisation when the honey is removed by the insect visitor, but upon which the scope of this address forbids me to enter, every bloom possessing some peculiarity, which might in itself furnish material enough for a lecture.

Honey, then, is provided by the plant for a definite object, and at cost to itself, and is not a waste product or excretion, as some botanists appear to have imagined.

In entering upon the next phase of our subject, the uses of honey as a food to bees and men, we must remember that foods are of two kinds: those that produce the tissues or material of the body, and those which

supply them with force and heat. Pollen is of the first description, and upon it mainly bees depend for nurturing their brood. Honey and all sugars are of the second class. Honey gives energy to the busy worker, and it also keeps frost at bay during the rigour of winter. In order to understand the origin of this energy given to animals in general, and bees in particular, by sugar foods, we must examine the method in which the latter are produced by plants.

Whilst the sun is shining, every green leaf extending its face to catch the power of its rays is engaged in drinking in both light and heat, which are but modes of motion, to borrow the title Tyndal gave to one of his admirable works. The chlorophyll granules, which impart to the leaves their green colour, are the instruments for turning this energy to use; and they, whilst receiving power, give out from themselves energy in turn, in building up starch out of water and carbonic acid, the latter, in large part at least, derived from the air into which this substance is being constantly thrown by the breathing of animals, decay, combustion, &c. The starch is only formed at the expenditure of immense sun energy, which is locked up, as it were, within it, existing as (what is scientifically denominated) potential—a power, which may at any future time reappear as the starch is reconverted into the substance from which it was at first elaborated. This process is the initial one in the formation of all plant substance, but since starch is insoluble it must be converted into some new body capable of solution, in order that it may be distributed through the whole structure of the plant, and become the vitaliser of every part.

This new body is sugar, into which starch most readily passes, and thus becomes a very highly diffusible substance, travelling along with the sap, and everywhere yielding that energy which is the accompaniment of life. In a growing potato-plant, by example, daylight and sufficient temperature being given the leaves are constantly at work starch-producing. The actual energy, *vis viva*, of the heat and light is changed into potential energy (the food power of the starch). The starch is converted into sugar, the sugar circulates in the sap, and in virtue of its potential becomes the instrument of plant-work. Wonderful chemical changes are brought about, sap is mixed with a force that is astonishing, roots push their way in the solid soil like steel prongs driven by a sturdy arm, big tubers are formed and drive all before them as they expand. We say, and say truly, this is the energy of life, but physical life can only direct and build into its own wondrous pattern. It can gather into itself energies at its disposal and utilise these as its servants. Energy it cannot create, and the power here at work in the potato-plant is a power which was actual in the sun and potential in the sugar. This point being clearly apprehended we shall have but little difficulty in realising the position which sugar, and consequently honey, occupies as a food to the animal world. Our attention as bee-keepers will naturally at first centre itself around the hive, and here we learn, as previously hinted, that the complete diet is made up of honey, pollen, and water. The pollen furnishing not only albuminoids, or flesh-formers, but earthly matters and salts in abundance.

The necessity of pollen for the production of grubs is so nearly universally admitted that it now needs no discussion; but not a few have supposed that the adult insect for its proper nutrition requires only heat-forming food. It must, however, be remembered that considerable and prolonged activity, such as we find in the bee, needs food of both kinds, for all animal exertion involves not only a break-up of force-forming material, but also a retrograde change of some nitrogenous matter, flesh-like substance; and this can only be resupplied by pollen. Honey, under natural conditions in the hive, always contains nitrogenous matter in small amount, or

is associated with it; but when honey is replaced by sugar, pure and simple, the absolute absence of albuminoids affects the bees prejudicially. Any properly conducted experiments would prove that severe and protracted cold could not be so successfully resisted by bees if they were provided with sugar alone, and for reasons which every physiologist would clearly understand. Indeed, Verloren has entirely put this matter at rest, and has shown that although a considerable amount of exertion can be un-dertaken temporarily on a diet containing no nitrogenous matter as sugar, still weakness and weariness soon supervene, quickly followed by complete muscular exhaustion. I take it that some advice which has been given recently in relation to feeding in winter has been misleading, and has arisen from views which, at the best, have been only partially correct. The splendid condition in which my own stocks pass through the most trying spells of cold would convince any one (and they are always open to view) that those who see the necessity for 'hooked wires' to clear out accumulating dead have not yet learned the secret of wintering.

The most restful conditions are those in which least nitrogenous material is required, because then least is worn out, and thick hive-sides and proper contraction of the hive-body will enable bees to pass the greater part of most winters in the state which most truly approaches hibernation. The condition at which we should all aim, and during which even the consumption of honey is surprisingly small, while pollen is almost, if not quite, unnecessary. But when the frost becomes intense the bees have to assume a semi-activity in order to oxidise sufficient material to yield heat more abundantly, and so maintain the temperature which is essential to their vitality. Under these conditions small quantities of pollen are most desirable, and the arrangement of nature is the right one.\*

Bees have on each side of the body seven beautifully constructed apertures, five between the abdominal segments and two under the wings. As the abdomen is elongated and contracted, air is continually taken in and then expelled. This air travels into every portion of the creature; and I recently had the honour of showing to the Royal Microscopical Society that every muscular fibre is provided with its own special aerating tube, some of which are so minute that a bundle of a million of them would only equal a hog bristle in thickness. The oxygen permeating thus every part of the organism is, as occasion requires, caused to unite with muscle and other juices; and in these (juices) sugary matters are burnt up and give out heat, while the sugar returns to the substances, out of which the plants frame it by power borrowed from the sun. Carbonic acid and water are the result, and the potential becomes actual heat. Heat is due to molecular vibration, and this molecular vibration may be converted into nerve vibration, or nerve activity, or muscular contraction, or physical movement. How beautiful, then, is this principle of 'storage of force,' not a thing of modern times and the property of electric light companies, but as old as the hills, and even older. The sun glows and gilds all; and the plants (the true 'traps to catch a sunbeam') gather in his energy, and incarnate it, so to speak, in their own material frame. The little busy gatherer flies abroad, cheered and warmed by the present sunshine, and returns with a

\* I have, since delivering this lecture, tried an experiment upon 4 lbs. 5 ozs. of bees shut up in a box, half of which consisted of perforated zinc. They were stood for seven hours before a window in the light, and allowed to worry, and then weighed. They had lost 5½ ozs. They were placed then in a cool pantry in a dark corner to pass the night, and in twelve hours the loss in weight was less than 7 oz. During this time they had remained in cluster, but in the light had, in large part, been constantly seeking an exit. In the first case the loss per hour was more than twelve times that of the second.

change of sunshine for the future in its honey-sac. The sun sinks lower and lower in his daily march, and presently the white mantle of winter covers the ground. But the sun, although absent, is still diffusing his warming, vitalising energy through the hive. The honey contains his beams locked up, and the "store" is but a store of sun-power in reserve. The sun is, then, in a sense, always with us. He leaves us, but not until he has given his deputy, and that deputy is heat-forming food, and that heat-forming food must always at some period of its history assume the exact character in which we find it in honey.

We now are in a position to study our last point—the value of honey as human food; and so strikingly is nature one, that we shall discover that in the economy of bees we have the key to the matter. We and they alike need constantly to form heat, and to be able to convert that heat into the various forces of physical life, and we all depend upon heat-forming foods as the origin of these forces. The bee takes but one form of force-forming food—sugar; we also take fat, but fat can always be traced back to sugar and to starch in the plant, so that fat can be regarded as sugar in a somewhat concentrated form. In bees tubes distribute oxygen direct to the fluids, in our case lungs take in oxygen and distribute it to about 60,000,000 cells, from which it is again gathered up by the blood, which blood in turn distributes it over the body. This blood contains countless multitudes of corpuscles, which gather the oxygen into themselves by uniting it with a substance they contain, and which then becomes brightly red. The myriads of these corpuscles transcend imagination; each one is  $\frac{1}{1000}$  inch in diameter, and from 120 to 160 could be placed flat on the cut extremity of a hair; yet a man of ordinary weight and health possesses such a multitude of them that, could they be placed in contact with each other side by side, they would form a line which would extend more than three times round the earth's equator. These oxygen carriers act precisely as do the minute air tubes of the bee's body.

If starch is taken as food it needs to be changed into sugar, and a special, or rather two special, ferments are provided within us to effect this change. The saliva during chewing begins to convert starch into the soluble sugar-form, and that sugar is the kind which we find in honey. In cane sugar (the sugar of the tea-table, whatever its source) an alteration is also necessary, and it is brought, by contact with the mouth, at once into the kind of sugar we have in honey; the very kind which, by absorption, can be at once taken into the blood, and do the work of yielding up its potential energy within us. Mr. Helmer, it will be recollected, pointed out that bees largely convert cane sugar into grape sugar (honey sugar), and so we see in honey we have completed for us those changes which are essential before sugar can be carried into our circulation. It is worthy of remark, that if cane sugar be (artificially) injected into the blood, it is immediately excreted as an intruder, whose injurious presence must be at once got rid of, but that the injection of grape sugar (honey sugar) is not followed by any such excretion.

We see already that no food is of any service until it can be brought into the liquid condition. Starch must be dissolved by alteration into a new substance before it can be utilised by plant or animal. Solution in water is the only portal into the temple of physical life. Honey contains food in a dissolved state exactly prepared for assimilation at once which places the sugars it contains at the very head of the list of sugar-foods, yet on this very account it should be associated with some less easily absorbed material. Sugars as absorbed are carried to the liver by the portal vein, and thence they are quietly transformed into the next condition (*glycogen*) and stored, and afterwards, as occasion demands, again liberated to pass in the form of grape-sugar into

the blood-current for oxidation and production of heat. If much honey be suddenly taken alone, it passes so immediately into the circulation that the transforming power of the liver is insufficient, and the overburdened organ becomes gorged, the circulation is overcharged with sugar and nausea is the result; but if the honey be associated say with bread, the former is during chewing successfully entangled with the starch and albuminoid substances, and is only set free in the stomach as the dissolving processes of digesting progress. Its slow liberation permits the liver to thoroughly overtake its task, and the blood receives from time to time only those supplies which the demands of the economy justify. Bread and honey is, therefore, a combination which the soundest physiology approves.

Let me point out the enormous amount of force these foods are capable of liberating within us. Every grain of carbon as forming part of sugar united with oxygen and converted into carbonic acid yields an amount of energy which would be equivalent to raise a man of ordinary weight twelve feet into the air. The work done within the body in maintaining it in conscious life is so great that only a part of the forces of our food can be put forth in activity without. The subject is so immense, and can be viewed from so many sides that I both feel that my observations have been unduly prolonged, and that much that might well have been said has been omitted.

In conclusion, let me remark that we receive honey as one of the good gifts of a bountiful Creator, who in it supplies us with energies from the sun, that great type of Himself who even though unseen is yet present with us the source and centre of all activity.

#### DISCUSSION.

The Rev. V. H. Moyle was sure they had all listened with the greatest possible pleasure to Mr. Cheshire's highly interesting address. Being under the impression that honey absorbed in combination with bread and flour was better than if taken singly, he had thought that if he could bring a few samples of bread or cakes to this Quarterly Meeting it would be a practical illustration of the value of honey as food. He had taken the opportunity about three weeks ago to speak to Mr. William Palmer at Reading, when he informed that gentleman of what had transpired at the Annual Meeting of the Association, and invited him to make some honey-biscuits or a honey-cake, which he (Mr. Moyle) promised to show at an exhibition opened in his parish, and also to bring up to the Quarterly Meeting in London, when, perhaps, the members present would test the biscuits and the cake. He had told Mr. Palmer that if he could not do this he (Mr. Moyle) would ask Messrs. Carr or Peck and Fearn to undertake it. Messrs. Palmer had complied with his request, and he would ask the ladies and gentlemen present to taste the cake and biscuits and give their opinion thereon. He was glad to say that the firm were quite willing, with the sanction of the Committee of the Association, to place some honey-cake and biscuits on their stand at the forthcoming Food Exhibition. He thought this would be a good step towards popularising the sale of pastry of this sort. He then called attention to an American pamphlet on the subject of *Honey as Food and Medicine*, and exhibited several bottles of prepared honey destined for the latter purpose, the uses of which were explained in the pamphlet. In conclusion, he stated that Messrs. Sutton (the seedsman) had responded to an invitation he had addressed to them, by issuing a leaflet giving the names of the flowers from which the best honey could be derived. They had, moreover, presented him with 2000 copies of this leaflet for distribution. They had also offered a collection of twenty-four varieties of the seeds of these flowers at a cheap rate.

Mr. Glennie said that he had heard and even knew of



cases in which honey, so far from being a food, was very little short of a poison to some persons. A relation of his always suffered from a rash immediately after taking honey.

The Chairman said that he was speaking to an officer of the Engineers recently who had spent a considerable time in India and the Himalayas. That gentleman had informed him that the honey produced from a certain tree, rhododendron, which was rather plentiful in that country, was absolutely useless and had been thrown away because it acted as a narcotic on those who partook of it.

At this stage of the proceedings the Rev. H. R. Peel was asked to preside in consequence of the Chairman being compelled to leave.

Mr. Peel said he was sorry that the area of Mr. Cheshire's remarks had been necessarily limited to honey as food, especially as he understood that Mr. Cheshire could have said a good deal on the subject of honey as medicine. At the General Meeting it was proposed, as they would all recollect, that a medical man should be invited to read a paper on this subject, and the Baroness Burdett-Goutts kindly promised to obtain the assistance of one for that purpose. The idea was that the paper should afterwards be printed in pamphlet form for circulation at the International Health Exhibition. He believed the Baroness applied first to Sir Henry Thompson, who confessed that he did not know much about honey as used in medicine. Then Sir James Paget was asked, who answered that he knew less. Doctors on this question did not disagree, but, much to the mortification of the Committee, were in general accord. He (Mr. Peel) then wrote to Dr. Lionel Beale, who admitted he was not at all competent to grapple with the subject. The doctors said this was a chemist's question, upon which application was made to Messrs. Savory and Moore, who received the Committee's deputation in a most friendly way, but admitted that honey was very little used as a medicine, so far as they knew; and they thought that adulterated honey was equal in value to pure honey for this purpose. After this, Mr. Hoker urged the Committee to take a similar course to that adopted by Mr. Moyle with Messrs. Huntley and Palmer, that was, in the event of Savory and Moore's non-compliance to go to Messrs. Squires or Dinnford. However, Mr. Cheshire was at hand to help them in their difficulties, and he had very kindly consented to fill the breach. He (Mr. Peel) would be very glad if Mr. Cheshire would, in his reply at the end of the discussion, be good enough to say whether he thought that pure or impure honey was of any value for medicinal purposes. Perhaps, he might be the means of enlightening Sir Henry Thompson and Sir James Paget on this subject.

Dr. Walker thought it was nearly impossible for any one to contribute a paper on the value of honey as a medicine. So far as he knew, honey was very little used in the profession, and when prescribed it was employed generally as a "ty-biter," that is, for the purpose of disguising or altering the taste of a nauseous drug. He had read up various books likely to give information before coming to this meeting, but could find little or nothing on the value of honey as a medicine. It was used occasionally for children as a mild laxative. He would be only too pleased if its value to doctors could be demonstrated. Mr. Glennie's remark as to the effect of honey on some persons reminded him of a circumstance reported in Xenophon's march of the Greeks, in which it was stated that several of the soldiers were taken violently ill in consequence of eating honey found on the journey. He thought it was impossible to give a reason why honey could be taken by some and not by others. That fact was simply an illustration of the old saying that what was one man's meat was another's poison. Doctors generally in such cases veiled their ignorance by ascribing this circumstance to

an idiosyncrasy. There was no doubt that honey was easily assimilated, because it was of that form known as grape-sugar. He had found the grossest ignorance prevail among the poorer classes as to the right food for children. For a small child bread and potatoes were perfectly useless for the purpose of nutrition. The younger the child the greater the difficulty it found in assimilating starch. It was well known that in the West India Islands the negroes, who were very poor and thin at other times of the year, soon picked up weight when the sugar season set in, owing to the easy assimilation of the sugar.

Mr. Neighbour called attention to a book in his possession, written about one hundred years ago, in which honey was recommended as an excellent cure for sore throats. There were also other valuable hints in the work, which he would be happy for any one to peruse.

A member wished to know whether pure honey and the so-called honey in the market were identical as an article of food, that is, whether one was as easily assimilated as the other, and would produce the same amount of force and energy.

Mr. Cheshire thanked the meeting for the kind way in which his observations had been received. He felt that all were greatly indebted to Mr. Moyle for the practical step he had taken, which he (the speaker) hoped would be the means of creating a public demand in favour of biscuits and cake containing honey as an ingredient. He had come up from Hastings hurriedly to attend this meeting, and had had time to make only a few notes before commencing to speak. In regard to Mr. Glennie's observations, he quite agreed with Dr. Walker that no explanation could be given of the fact that honey from any source was injurious to some persons. This must be put down to an idiosyncrasy, as had been stated. It was well established, however, that honey produced from some plants was really injurious, and that probably that from the Azalea Pontica and *Kalmia latifolia* caused peculiar effects to which Xenophon referred, — a kind of stupefaction. There was always present in honey besides the two forms of glucose to which he had referred, an animal acid, which had not yet been properly made out by chemists. The acid seemed to be serviceable in cases of sore throat and other inflammatory symptoms. Why it had a curative effect it would be difficult to say for certain, but one might theorise and ascribe this fact to the readiness with which it enters into combination with mucous tissues. Honey was variable, and therefore its value as a medicine could not always be the same. The honey derived from orchard blossoms had a very distinctive character indeed, while that taken from clover was very delicate in flavour. The food value depends on the presence of two glucoses. With regard to the question as to whether adulterated honey is as nutritious an article of food as pure honey, he thought the answer must be emphatically "No," for the reason that this so-called honey consisted largely of corn syrup, which contained a sugar not so readily broken up as glucose, and therefore not so readily converted into carbonic acid and water in the body, and which consequently demanded a larger amount of force to assimilate it than was necessary in the case of pure honey. Corn syrup was very cheap, and was therefore used freely in the manufacture of pseudo-honey. In conclusion, he again thanked the members for their kind receipt of his remarks.

A cordial vote of thanks was passed to Mr. Cheshire for his interesting lecture, who briefly acknowledged the compliment, after which the proceedings terminated.

The names of the Rev. E. Barrum and the Rev. F. G. Jenyns were omitted in our last issue as having been present at the Committee meeting held on May 15th.

## MIDDLESEX BEE-KEEPERS' ASSOCIATION.

## NOTICE OF SPECIAL GENERAL MEETING.

It being very desirable that the Committee of the Association should include gentlemen from all the districts in Middlesex which are not at present represented on it, in order that the Association may be established on an extended basis, a Special General Meeting will be held, by kind permission of the Royal Society for the Prevention of Cruelty to Animals, at their Board Room at No. 105 Jermyn Street, London, on Tuesday, 24th inst., for the purpose of electing such members on the Committee in the place of others who are willing to retire, and of reconsidering the Rules of the Association.

The chair will be taken at 5 o'clock, either by the President, the Right Hon. Lord George Hamilton, or by the Hon. and Rev. Henry Bligh, one of the Vice-Presidents of the Association; and the meeting will be addressed by the Rev. H. R. Poel, as a deputation from the British Bee-keepers' Association, and by F. R. Cheshire, Esq.

Any persons in Middlesex interested in bee-keeping, or who are desirous of becoming members, are invited to attend this meeting, or to communicate with F. KENWORTHY, *Hon. Sec.*, 55 Coleman Street, London, E.C.

## LEICESTERSHIRE BEE-KEEPERS' ASSOCIATION.

The Committee of this Association met on Saturday, June 7, in the Mayor's parlour, Old Town Hall, Leicester. Mr. W. S. Pridmore was voted to the chair. The offer of the Melton Horticultural Show to find half the prizes was accepted, and the prize schedule prospectively drawn up by Messrs. Bickley and the Secretary was adopted.

After some discussion on the appointment of an expert, it was concluded that the funds of the Association were not at present sufficiently strong to bear the expense; but, as a substitute, it was proposed and carried that the following members, viz., Rev. T. W. Goddard, Dr. Emmerston, and Messrs. Johnson, Ward, W. S. Pridmore, Meadows, Riley, and Goddard, be requested to act as local advisers in their respective neighbourhoods for such members as needed their assistance and were willing to pay travelling expenses when incurred. Several of the above gentlemen have already intimated their willingness to act.

## DEVON AND EXETER BEE-KEEPERS' ASSOCIATION.

The County Show of the Devon and Exeter Bee-keepers' Association was held in conjunction with the Devonshire Agricultural Society's Show on May 21st, 22nd, and 23rd, at Exeter, in splendid weather. Among the exhibitors of collections of apparatus was Mr. Baldwin, of the Bromley Apiary, Kent. He showed a new arrangement of supers, by which the size of the super can be reduced to suit the season, so as to prevent a large number of incomplete sections at the end of the year. Another super, set for use on the old straw skep, enables cottagers to take advantage of the new method of supering without having to abandon their own straw hives. A new feature in this collection is a moveable comb straw skep. Mr. Moxey, of St. Martin's Lane, Exeter, showed a very large collection of hives, many of them being on the Griffin pattern; also an observatory-hive stocked with Carniolan bees; and straw skeps, quilts, section trays, travelling crates, a new honey-extractor of a cheap character, and zinc dividers of his own pattern. Mr. Moxey's new observatory-hive merited special attention. Messrs. Richards and Honey also displayed a handsome collection of apparatus, among other things a glass hive and glass super. They showed as well an observatory-hive and others on

the Griffin pattern, besides abundance of useful articles in the shape of smokers, wooden dividers, and comb foundations. Mr. Wilcox, of Tiverton, showed straw hives for cottagers in several patterns, all of a very useful character. There were specimens of the larger class of honey-extractors, as well as cheap wooden hives within the reach of the cottager's purse. A few sections of last year's honey were staged for exhibition. The bee-tent was erected in close proximity to the show of apparatus, and therein Mr. Baldwin conducted manipulations. Besides driving bees from hive to hive, he gave short addresses at intervals during the afternoon in the bee-tent upon the method and management of bees, not only in straw skeps but also in bar-frame hives, more especially suitable for the instruction of the cottager. These manipulations were continued daily throughout the show.

## ANTRIM AND DOWN BEE-KEEPERS' ASSOCIATION.

On Tuesday, 3rd June, eight gentlemen met together for the purpose of forming the above Association. A proposition has since been received from the Armagh B. K. A.: 'That as there are not sufficient bee-keepers in any one county to sustain an association for itself, there should be an association formed called the North East of Ireland B. K. A., having Belfast for its centre, and that the existing societies becl amalgamated with it.' At an adjourned meeting held on Saturday, 7th inst., it was resolved that the next meeting be held on Thursday, 19th inst., when deputations are expected from the Armagh and Tyrone Bee-keepers' Associations to consider the above proposition.

## RUDIMENTS OF BEE-KEEPING.

(Continued from p. 183.)

## THE HONEY HARVEST.

Bee-keepers, at the commencement of their career, are often discouraged by finding little honey gathered, and the results of the first entire season of management most unsatisfactory. Supers are not taken to by the bees; stocks in spring get weaker instead of stronger, and improve only very slowly; the advantages and profitability of intelligent bee-keeping appear more and more unreal. The fault may invariably be looked for in what may be termed the nursery of the hive, in the production of brood. When hives dwindle in spring, this arises from the hatching brood failing to keep pace with the death-rate. And, as honey becomes plentiful, and bees die in greater numbers, the task of increasing the amount of brood becomes the more difficult through the smallness of the population. Stocks remain weakly far on into the year, and the best of the honey harvest is practically over before the labourers are ready to gather it. Now there are two great causes for this state of things: (1) either the queen is afraid to begin early egg-laying, through the smallness of the store of food in the hive, or (2) she has become too old, and should have made way last season for a young, vigorous queen. The fertility of the queen and the ability of the bees in early spring to tend and feed a large and increasing number of her brood, are the two great secrets of a successful honey harvest. Let hives, therefore, in autumn be packed with a supply of food sufficient not only to keep the bees alive, but also ample for the rearing of young bees in spring at the earliest opportunity. With starvation staring them in the face, how can we expect the bees to venture upon largely increasing the consumption of food by rearing a suitable amount of brood? Again, a young, vigorous queen will eagerly take advantage of the first moment possible for brood-rearing. Indeed, she may keep such a succession of young bees up

throughout the winter as to have the hive full of strong workers ready for the early spring work, instead of a number of aged, worn-out ones. An old queen, incapable of laying the necessary number of eggs, of course implies a less numerous population and a reduced honey harvest.

The present is the moment to think about the young queens you are likely to need in your hives before next season. The safest and simplest course for a beginner is to find a strong stock, the queen of which is known to be both young and prolific, and in which there are queen-cells in a forward state; in fact the hive ought to be on the point of swarming. Remove the queen, and, following the directions given in Cowan's *Guide-book* or other books, introduce her into a hive, from which the old, worn-out queen has previously been removed. The result will in every way be satisfactory. The good queen will soon improve the strength of her new hive. The hive from which she was taken will have its desire for swarming checked. Possibly its bees will hatch out the young queen from her cell, and, finding the succession of brood interrupted, will consider swarming unnecessary, and settle down to work at supers; or if they do swarm, the swarm and the old stock will both of them have a young queen of the present year.

'Why will not my bees work at the supers?' is often asked. 'Why?' Because they do not at present require the additional room, or because they made up their minds that they were overcrowded before the supers were offered them, and in consequence commenced preparations for swarming. And swarm they will. If the desire for swarming is to be prevented, room, both in the brood-nest and above it, must be liberally given as the bees increase in numbers. If they find room enough, they will not wish to swarm; on the other hand, if they once make up their minds that swarming is desirable, your hive will be stopped in gathering surplus honey as soon as the swarm issues, and the moment in the season will perhaps be lost when most honey is obtainable. Our hives, then, should not be weakened by swarming, if this can possibly be prevented. They should be full of bees at the earliest moment possible, and a super should be offered them, into which they can overflow, and in which their honey can be stored. If much honey is obtainable, it is surprising how quickly a super will be filled. But unless honey is coming in, we cannot expect hard work in the supers. In bad weather it will perhaps entirely cease, and the bees will leave the super. No more will the bees work in sections which they have no honey to fill than a man would work at extra house room which he does not need. Again, it is useless to hope for work in supers unless the brood-nest is fully occupied below. When once more room is required, and honey is plentiful, the bees will eagerly occupy the supers, and supply you with honey of the best quality. F. S. SELATER.

## Correspondence.

\* \* \* All Correspondents forwarding Letters for insertion in the Journal, Reports of Associations, Shows, Meetings, &c., should be requested to direct their communications to 'The Editor of the "British Bee Journal," c/o Messrs. Strangeways & Sons, Twelve Street, Upper St. Martin's Lane, W.C.'

### HONEY AND WAX DEPÔT.

You will, in the interests of bee-keepers, be glad to learn that the promoters of the Honey Dépôt are receiving communications, inquiries, and offers of honey and wax from all parts of the island, and that already very large quantities are steadily flowing towards Reading; so that a fresh industry is being opened, which is proving a great help to bee-keepers generally. The promoters of the Dépôt are doing all they can to get some manufacturers of

beverages as well as makers of articles of ornament and utility to use honey and wax largely, and so increase the demand for pure unadulterated British and Irish honey; and successfully too: Messrs. Huntley & Palmers' venture is being well appreciated and responded to, as their 'Honey Drops' are in large and increasing demand. I shall be glad to give information to all who want it as to terms, &c. for honey, extracted and in comb or sections, or wax, as the promoters are prepared to take all they can get of these pure and unadulterated articles.—V. H. MOYLE, *Brook House, Burghfield, near Reading, June 10th.*

### TEMPERATURE OF HIVES.

I read with great interest the observations on the 'Temperature of Hives' in your last issue. Would 'Amateur Expert' be so good as to say how he took the temperatures? with what sort of thermometers? and how he inserted them into the brood-nest? I have tried, but did not find it an easy matter to get the temperature of the brood-nest accurately. Huber put the usual temperature of hives between 95° and 97°, and in winter in strong hives, even when there were several degrees of frost, between 86° and 88°. I have not tried in winter, but the temperature of a straw skep was taken daily at 7 a.m. from March 30th to May 26th; the thermometer only twice registered below 94° F., and only once as high as 95·8° F. During April the thermometer varied from 94° F. to 95° F., and only once stood above 95° F. During May it varied from 95° F. to 95·8° F.; it did not go below 95° F., and only once reached 95·8° F. The hive was never fed, but was weighed daily; its weight was increasing till April 5th, when bees and comb weighed 23 lbs.; it diminished very steadily from this till May 11th, when they weighed 15½ lbs. In the next two days it gained 3 lbs., and on the 17th the bees swarmed; it was a fairly strong hive, drones were flying from it in March. The temperature was taken with a thermometer nearly a foot long, graduated to fifths of a degree Fahrenheit. The thermometer was thrust through the top of the skep, leaving only the top of the index and about four inches of the glass projecting. This was protected by an inverted flower-pot, over which were laid sugar-bags and felt. The thermometer was not disturbed during the whole time, so that its index must have risen and fallen very constantly with the part of the hive the bulb was in; but I do not think that it registered the full temperature of the brood-nest; possibly it registered more than a degree too low, for on lifting off the flower-pot the index would fall a degree or more very quickly, whereas the temperature of the brood-nest would not have altered in that short time.

On March 27th, which was cold, and the bees remaining in-doors all day, I watched the temperature of a strong Raynor hive with the above-mentioned thermometer thrust through the carpet between two frames. From 9 a.m. to 11 p.m. it varied only between 93° F. to 94° F. This hive had ten large frames in it; the bees had wintered on them and could not have wintered better; the bees at the time were only covering seven or eight of them.

I have described the conditions of these observations at this length in hope that 'Amateur Expert' will explain the reason that I have registered more uniform temperatures than he has, for at present his observations have rather unsettled my ideas of the temperature of hives.—G. D. HAVLAND, *St. Bartholomew's Hospital.*

### LANTERN SLIDES.

In noticing a series of lantern slides I exhibited at the Health Exhibition (they were not shown by Mr. Dawson by the way), you remark upon their use in illustrating a lecture.

In my short experience of lecturing I have found

illustration by means of the lantern to be of the greatest possible value; it enables you to engage the attention of the audience not only by means of the ear but through the eye; in fact, it requires a really talented speaker to thoroughly hold the attention of his audience in a semi-scientific subject like bee-keeping, when he has no graphic illustrations to help him. I have often thought that the 'British' would be doing a good work if they got up a thoroughly representative set of lantern slides. I for one should be happy to lend the best of my negatives, and I think there must be several others who, like myself, are photographers as well as bee-keepers. Probably most of the County Associations would subscribe for a set, so the enterprise need not be costly, and then with the help of a modern three-wick lantern and a portable screen lectures would be much more frequent and interesting than they are at present. My own set I have made more complete by the addition of some ink diagrams (also on lantern slides) of hives, exterior and interior; also practical mottoes, such as 'Give more room as the hive gets crowded,' 'Keep your stocks strong,' &c., and sections of fruit-blossoms showing the stigma, pistil, and nectary (the natural object pressed between the glasses). Of course the making the slides would have to be done by professional hands; I need scarcely say I have no 'axe to grind' in the matter (to use an American expression), as I have never sold any photographic productions. I may add that I think photos from nature are far more attractive and useful than mere copies of woodcuts; there is scope for plenty of work in photographing the different bees and cells (no easy task), and securing natural pictures of operations in bee-keeping, such as hiving a swarm, transferring, &c. I hope to do more in this direction; then artistic photographs of bee-gardens in different parts of the world would be most interesting.—ALFRED WATKINS, *Widcroft, Hereford.*

#### BEE-KEEPING AN INDUSTRY FOR LADIES.

I was much struck the other evening by hearing a party of young ladies reading in the *Staffordshire Advertiser* an account of Miss Gayton's successes with her bees, and asking each other why they too could not make sixty pounds in one year by bee-keeping. If secretaries of County Associations would send to their county newspapers such extracts from the *Bee Journal* as would attract general attention and awaken general interest, they would soon find a great increase in the number of their members.—AHS CECROPIA.

#### ROBBING.

June 1st.—A strong swarm issued from a stock of Ligurians at 11 a.m., settled in a goose-berry bush, easily lifted and placed on stand thirty yards distant from parent stock in one hour from time of swarming. All appeared to go well that day; next day I noticed unusual activity in stock and swarm,—concluded robbing was going on, and found it so. Swarm robbing parent stock, but in a most friendly manner; there was no fighting, they came and went as freely as others. I was at a loss how to stop it, but thought that syringing swarm with scented syrup would be the best thing to do. At night, when all was quiet, sprayed every frame well on both sides and all the bees. Next morning was up early to see the result, and found same thing going on again, quite friendly; so had to wait for night again, when I moved old stock thirty yards away, and ten from where swarm stood, and moved swarm on stand of old stock.

Again up early on the 4th to see result, which was that robbing was stopped, but a great number of bees from swarm were flying about the place where first put, which continued all day, many finding their way into a hive about two yards from it, where they were received quite

readily, and numbers from old stock finding their way back to old place and joining swarm, but at times with difficulty; but I think that there were not more than two dozen lost.

I noticed that those seeking admission into strange hive approached with quite a different hum to what the robber makes, which may account for their being accepted. Towards dusk I picked up about two dozen that had alighted on some currant-trees; one dozen I placed at entrance to swarm—they were accepted; a dozen I placed at entrance to hive, about two yards from place where swarm first stood; they were accepted, and, strange to say, nearly all bees that came out of the latter hive on being disturbed by strangers going in were Ligurians. I also placed a few at entrance to old stock, and they were accepted.

Permit me to add that when I opened the frames to spray the swarm I was astonished to find that they had very nearly worked to the full extent eight full sheets of comb-foundation in thirty hours.—M. WHITTLE, *Lockinge, Wantage.*

#### HOGES' HONEY.

I see by the label on the Hoge's honey that he calls himself 'Purveyor to Her Majesty the Queen.' How has the patronage been obtained? Can you tell me the name of the distinguished chemist under whose formula the Hoge's honey is prepared?—AN ANXIOUS INQUIRER WITH A SORE THROAT.

#### MR. HEWITT'S WAX-SPOON—MR. CLUTTEN'S FOUNDATION-FIXER.

For the benefit of those who find the putting in foundation—both in sections and frames—one of the trials of bee-keeping, as I did till to-day, I should like to mention that I find Mr. Hewitt's wax-spoon and guide perfection, while for frames where the top bar is split Mr. Clutten's foundation-fixer is invaluable.—A HAMPSHIRE LADY.

#### A RANDOM SHOT.

Some time ago, in an editorial article on 'Bee-keeping as an Industry for Women,' you mentioned the names of several English ladies who had distinguished themselves by their ability in the management of bees, instancing among others the late Miss Stirling Graham, of Duntrune, and Mrs. Bellairs, the wife of E. Bellairs, Esq., Wingfield, Christchurch, Hon. Sec. to the Hants B.K.A. No doubt your bow was drawn at a venture, but the random shaft was better aimed than you dreamed of, for I note in the last annual Report of the Hampshire B.K.A. the following sentence:—'The *British Bee Journal* has recently, in grateful terms, alluded to the services and skill shown by Mrs. Bellairs in bee management, and in coupling her name with that of the venerable and late Miss Stirling Graham, of Duntrune, the writer was probably unaware that the first lessons (about bees) of the former were obtained from the latter.'

'Many a shaft at random sent  
Finds aim the archer little meant.'

In the same report there is a very graphic account of the difficulties and arduousness of the voluntary manipulators at County Shows which might well bear transference to your columns.—MELISSA.

#### PURIFYING BEES' WAX.

Your correspondent, 'R. E. C.', in last issue, asks that I would communicate through the *Journal*, for the benefit of bee-keepers, my system of cleansing and preparing wax similar to that to be seen amongst my exhibits at the International Health Exhibition. To me it is always a pleasant duty to diffuse any little knowledge I possess

for the good of others, and I am therefore pleased to give, for R. E. C.'s especially, the following simple directions. First, I might say that I store all waste combs during the season late in the autumn, when bees are clustered and few about. I fix an old iron boiler in my garden, put the comb into bags made of common strainer-cloth, and melt all down, skim off the wax as it rises, throw it into cold water, then take it out and put it into strong earthen jars, and place them in the boiler, heat it down. Leave it to cool, when all refuse will settle. Turn it out and remove the sediment, break up the fine, and put it into a clean earthen vessel, a common jug with lip is best, place it in a boiler and again melt it down, prepare moulds, dip them in cold water, and leave to drain for a moment, then pour in the hot wax, and leave till cold, when it will turn out clean. R. R. GOSFREY, *Grantham*.

#### GOOD LUCK, INDEED!

In Sussex recently a swarm of bees, upon issuing from the hive, mounted high into the air and started off. The man in charge of the garden, hoping to recover them, followed the bees, and, after dining so for rather more than a quarter of a mile, was delighted to see them coming towards him, until he found himself surrounded. Whether from fright or not he took his hat off his head, when, to his astonishment, the bees took possession of it, and he was able to carry the hat and its occupants home on his shoulder and hive the swarm.—FRANCIS S. SELATER.

#### KILLING ROBBERS.

I have often wondered by what means bees who guard the entrance of a hive kill robbers, as hitherto I have failed to discover any visible signs upon them which might throw any light upon the matter, except that their bodies are much drawn upon and contracted. This morning, however, I found enclosed bees in front of one of my hives. The robber was quite dead, while the defender, whose sting had no doubt caused the death of the robber, was unable to detach itself from its enemy.

Thinking the above may be of some interest to bee-keepers, I have pleasure in forwarding the bees for your inspection. OXING.

#### MR. HEWITT'S HIVES—SYCAMORE HONEY.

I notice your correspondent J. Hewitt's recommendation Dutch gin-cases as suitable for bee-hives. I have used them as 'make-shifts' for years, but think their sole recommendation is that they can be adapted to take Standard frames. I used them for Baldwin's frames before 'Standards' came into existence; they are, however, altogether too slight and thin for winter, and I have only used them at swarming time and in warm weather. Certainly I have just wintered a driven stock in one of them on some spare frames from other hives, but I was careful to place the whole arrangement into a larger box, and gave plenty of warm packing, so of course they came out all right, but they would never do to stand a severe winter in this country. Mr. Hewitt has never seen or heard tell of any one using them, but for his information I can tell that gentlemen that the 'green' cases, and also the 'red,' are largely employed for hives throughout Tasmania, Australia, and New Zealand, just as skeps are here and without frames, as I can testify from personal observation in 1881-82, but then the climate in those countries is very different from ours. In Australia bees seem to thrive in any old box so long as it is protected from the sun. In New Zealand I met with some fairly well-constructed frame-hives in Nelson, Canterbury, and also Auckland.

I should not have troubled you with this were it not also for some remarks you print from the same gentleman

with regard to sycamore honey. Now, while agreeing that his statement may be perfectly correct, that honey from sycamores may be both abundant and of 'delicious flavour,' I strongly object to his seeming teaching that the nasty insect secretion termed 'honey dew,' that he refers to as only requiring 'fading into the combs,' is at all of a 'delicious flavour,' or a desirable compound to have mixed with one's honey. Finding my bees gathering 'honey dew' from sycamores (and the bloom of these trees being about over), I removed my supers that the bees should only make use of it in the brood-nest.

Last year the sycamores were clean by reason of occasional showers, but this year we have not had a drop of rain for some time. The secretion, I observe, comes from a green aphid very similar to if not the same as that which infests our rose-bushes. I have seen it asserted that all 'honey dew' is the secretion of some insect, and am inclined to the belief; but still I have noticed for years bees frequently gather from fields of tares before they are in bloom, and also when in bloom, with out visiting a single blossom, and I have failed to trace any insect visible to the naked eye, but doubtless the microscope could unravel the mystery. The honey (?) gathered in this manner from tares is pure white, and has a slightly alkaline flavour.

I trust you may think it advisable to warn bee-keepers to beware of 'honey dew,' and, as bees will gather it at times, to take precautions against its going into supers as the genuine article; it is disagreeable stuff at best, and spoils the flavour of real honey. I write this solely in the interest of what should be every bee-keeper's chief endeavour, viz., the production of pure honey; and since honey is used as food, to quote Mr. Cheshire, 'how important it is that it should be obtainable in a pure condition!'

We are now having some most refreshing rain, which I trust will wash the secretion from the trees, and as soon as clover is in bloom, on go supers again! M. H. MATTHEWS, *Wood Green*.

#### MR. SIMMINS' SUGAR FEEDER.

Having had some correspondence with Mr. Simmins this spring, in which he very courteously told me of his new sugar feeder, I wish to endorse his remarks. I have had the feeder in use in twenty-three hives; it has answered admirably, and with me will certainly be the feeder of the future. The honey flow ceases here about the middle of July, consequently breeding does so as well. I intend trying it at that time to prolong egg-laying if possible through August, which, if successful, ought to be a help in the spring; that anxious critical time of the bee-keeper.—J. C. LAUREL, *Hull*.

#### CURE FOR BEE-STINGS.

Throughout the whole of last bee season I used and recommended it to many others, who found it equally efficacious 'Hudon's Dry Soap,' a little of it moistened and applied will at once allay all pain and swelling. It is so very cheap that I think so simple a remedy should be widely known among bee-keepers. CHARLES ROBERTS, *60 Brook Street, Chester*.

#### ANOTHER FUEL FOR THE SMOKER.

Seeing a note in the issue of the 15th ult. on the above subject, I would mention what may not be known to all the readers of the *B. B. J.*, that the black fungus which is to be found growing in the cellars of liquor vaults makes one of the finest fuels possible, inasmuch as it is portable, will not go out, and gives out a continual smoke. Most brewers consider this fungus an ornament to their cellars, and do not care to part with same.—W. D. ST. AOE, *12 Promenade Villas, Cheltenham*

## HINGES TO HIVES.

The enclosed sketch may possibly be of use to some of your readers who have double-storied hives, and like them to open with hinges. The top half of hinge is screwed to the roof, the lower half slips into a socket,

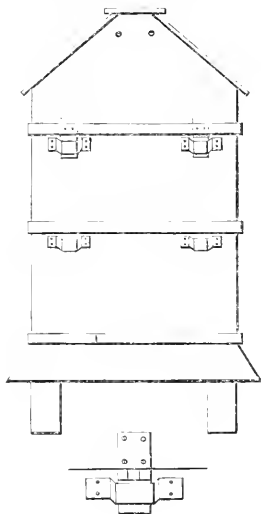

which is a piece of hoop-iron bent and screwed on to hive body. When you want to take away the upper story, you lift the roof straight up and the hinges come out of the socket, and are all ready to fit into the sockets on body of hive; it opens just as if it was screwed on.—S. GEORGE LITLEDALE, *Wick Hill House, Bracknell.*

## HONEY EXTRACTOR.

I have for some time past used a honey extractor of my own invention and make, which is very simple and

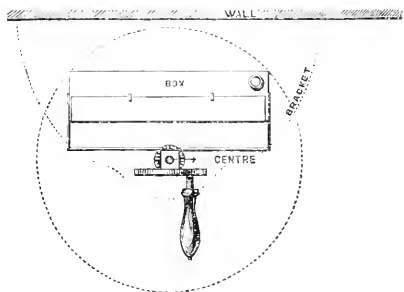

effectual, and cheaper to make than the other extractors now in use, which in my opinion do not answer the purpose so well. I have shown it to many friends

who have called upon me, interested in bee-keeping, who are surprised to see so simple an appliance work so well.

A gentleman who has seen it recently has induced me to send particulars to your *Journal*, in the hope it may be of service to those bee-keepers who, like myself, make their own appliances.

I send herewith a sketch drawn by a friend representing the extractor in position ready for use. The

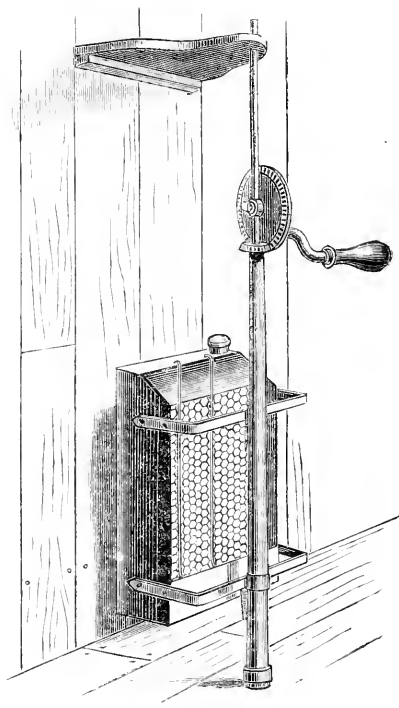

upright is made of  $\frac{1}{2}$  round rod, with collar on the bottom about 2" worked square below the collar to keep it from turning round in the socket. The portion which works round the rod is an old gun-barrel, fitted with a small bevel wheel at the top end. Further down the barrel are fixed two eyes with collar, as shown, in which the can hangs. An eye should also be made to be fixed to the rod, with a small arm on which to fit the larger bevel wheel with handle, represented on sketch. The tin can should be made to hold nine sections, to suit Standard frame. Two iron or tin straps are fixed to the can, with stearts in the centre of each to slip in the holes projecting from the barrel. I may say that the two wheels can be obtained at Lloyd's, Steel House Lane, Birmingham, for 1s., and that if there should be any difficulty in obtaining a gun-barrel, a piece of gas-pipe would answer the purpose as well.

There are several of the extractors at my house in use when needed, and shall be glad to show them to any one who may call at any time.—THOMAS OWEN, *Wiltshire Cottage, No. 7 Shaft, Corsham, Wilts.*

## LAST QUARTERLY PAPER.

May I ask, Mr. Editor, why no report of the last quarterly paper and the discussion thereupon has appeared in the *Journal*? The *Conversazione* was held on the 16th of April, and I have been for special reasons particularly anxious to know what took place at it, but no account of it can I find. I suppose that it must have the origin of some heresy or schism, and that it has been suppressed for this reason. Pray give us some explanation as to the cause of the delay.—RUSTICUS' EXPECTANS.

[Mr. Cheshire's lecture was delivered *viâ* *cave*; and his numerous engagements have hitherto prevented him from reducing it to the form it assumes on p. 200. We trust that 'Rusticus' will now find his expectancy gratified.]

## REPLY TO H. V. E.

All right, friend Edwards; but what do you mean by 'committing female bulls'? How did you know that I was a Justice of the Peace? Can I have committed myself? And why should I commit female bulls? True, I was thinking of *Coves* as a residence when I return from Ireland, but how did you know this? You must be a prophet—the Derby Prophet. Did you prophesy the Dead Heat?—HAMSHIRE HOG.

## DEEP &amp; SHALLOW FRAMES.—SECTIONS.

T. W. Cowan, Esq., on page 160, says, 'The large hives, such as the Layens, are not at all suitable (*i.e.*, for honey in sections on the top), as they are too deep. . . . The frames should be shallow, and reserved for brood only.' Will he please explain this, and give us the evidence which causes him to regard these statements as correct, and say why bees in the Stewarton hive, with a brood-nest 14 in. to 18 in. deep, store honey so readily in supers above? Also, if bees will yield a greater profit by using a deeper brood-frame—as I know they will—why bee-keepers should be required to use one 8 in. deep?

A little farther on he recommends the American Standard sections, 4½ in. square and 6½ in. x 5½ in. Will he please say why British honey-producers should dress their honey in American robes and send it on the market in such a shape that it can't be discerned from American, thus enabling questionable American honey (which might spoil their own market at home) to be sent here and sold as 'English'? This is a serious matter, and I trust he will duly and seriously consider it. If the Committee of the B.B.K.A. were composed of merchants or manufacturers, they would in a moment recognise the point, *viz.*, that to command the best price for your best goods, you must not dress and label them as you would the common.—JOHN HEWITT, *Sheffield*.

## WIRED FOUNDATION.

J. S. Borcham on page 168 gives a very crude way to make wired foundation; he wrote to me a short time ago, giving the plan, putting in three brass wires; I cautioned him against using brass or any but *tinned* wire, or heating it first, and telling him of the American plan of 'wiring' the frames<sup>7</sup> where seven wires and two cross ones are used in a Langstroth frame; also telling him I intended taking the matter up in the *Journal* as soon as possible.

Those who are thinking of making this had far better wire the frame on the American system; 1 lb. of No. 30 wire will do 175 L. frames, and so popular is the system becoming that A. I. Root says he is getting the wire in by a ton at once, and he is not the only dealer in the wire; any kind of foundation will do, and if *tinned* wire is used the brood is not killed as Mr. Cheshire said it was. I have devised a very superior way of wiring frames with thin bottom bars, which I will give shortly. Query: Who are dealers in No. 30 tinned soft iron wire in this country?—JOHN HEWITT, *Sheffield*.

## NOTINGS FOR THE JOURNAL.

*A Bee-Veil*.—Knocking about amongst bee-keepers, one often sees and hears quaint sights and queer remarks. While visiting a bee-keeper of some twenty-seven hives in Westerdale, and in driving a hive of bees for him, he bolted for his bee-veil; and judge the surprise and amusement of myself and a friend who had accompanied me, to see advancing towards us a veritable facsimile of the illustrations in the *Graphic* of the Kelly gang of bushrangers, the bee-veil consisting of an old stable lantern tin perforated with many holes, such as you used to see about when we were small boys, with horn for a door. We laughed outright at our bee-keeping friend in tin helmet; he was a humorous fellow and joined in the mirth.

*Queens taking an airing*.—By the way, has any brother bee-keeper ever seen his queens out for an airing on a bright sunny day? I upon several occasions have seen a queen come out and circle about for a few minutes and run in again. I noticed this last autumn, and watched carefully for some weeks every fine day, and saw more than one queen come out and circle round two or three feet and then run in again. If this is a common practice it will account for some of the many losses in queens.

*A Plea for the Blue-Tit* (*Parus Caroleus*). In common with other bee-keepers in the early winter months, I was highly indignant at what I considered the ravages of the blue-tit. Several of them at morning and evening paid regular visits to my hives, then retired to a favourite perch to eat the captured bees, and on the spot were numerous stings, giving the inference that the tit was a most destructive fellow in an apiary. I even made up my mind to trap a few; but as this was such a barbarous method I purchased some birdlime, and while carefully watching to take my captives, I soon altered my mind, and came to the conclusion that my bees were groundless, and am glad to say I did not wring the neck of a single tit. My reason for changing my mind was that out of many weeks of watching, and from as short a distance as eight feet, I never saw the tit touch a live bee, but, on the contrary, they are the most indefatigable scavengers in gathering up the dead bees, and retiring to their favourite perch, and there plucking out the sting, and eating the choicest morsel, just as has been many times described in the *Journal*.

*Different Races of Bees*. A correspondent of the *Journal* wishes to have set at rest forever the superiority of English or foreign races of bees. This is a question like that of hives—unsatisfactory to answer, not for want of knowledge but for the ignorance of novices. An expert bee-keeper will keep bees with profit in an old cask or box of any description. So it is with bees; in one person's hands they are everything that is desired, and the same race of bees in another's, from some error, will fail to give the same results. I see the same correspondent questions their abilities in the north or at high altitudes. I can only say that I have kept the pure race and hybrids close to the sea-coast, where the said sometimes half drifted over and into the hives; and I have kept them a few miles from the top of Stanimore, one of the highest and bleakest parts of England, and never yet had any cause to complain of their working qualities; and would not be afraid to compete in a Bligh Competition with Ligurians against blacks, or hybrids against both races. Without doubt they are vigorous fellows, and, to use an Americanism, vigorous at both ends. They are more active than the common bee, they are better by far breeders and better honey gatherers, and, of which there is no doubt, their last qualification, better stingers as well. Why, like the weather, we must put up with some clouds, or we could not appreciate the sunshine.—W. CRISP, *Great Ayton, Yorks.*

## THE MANUFACTURE OF STRAW HIVES.

For the information of those of our readers who may feel interested in the production of straw hives we give below an illustration of *Oettl's* frame, so much used on the Continent. There are, of course, several others, more or less known, on the other side of the Channel, among which the Rev. Bedé's is probably one of the most popular; but whatever their individual improvements or adaptation, they are none the less all based upon the main features of *Oettl's*.

This frame was, first of all, adopted in Germany for the manufacture of their square straw hives. It consists of a circular base, with a double row of stakes or pegs between which the straw is pressed. A lever, *e, u, s*, of a 1' shape, travels over the stakes or pegs and presses down the straw.

A strong pin, which is put through the holes in the upright shaft, *l*, keeps the straw in position whilst it is being stitched together. Sections of a circle, like the one marked X, are used as a means of facilitating this pressure, but they can be dispensed with by the practical hand. As the rows of straw keep rising so does the lever, which is fastened to the pivot, *q*, by the pin, *d*.

The pattern here represented is supposed to be made of oak or elm wood, and the double row of pegs seen projecting from the frame are of two kinds, as our illustration shows. Generally speaking, the upright shafts of those made of late are of iron. For instance, the two patterns exhibited by M. Bedé had their iron shafts fixed upon a wooden frame, and their lever was of the same metal. Frames built upon this principle are cheaper and more solid as well. When working with them no stitch is made until the shafts are full of straw up to their top. The stitches are made straight, running either upwards or downwards. The rest of the operation needs hardly any particular explanation. For rectangular hives, having straight

walls, the lever has to be displaced in rotation with the pivot upon which it rests. At a recent show, held at the Orangeries of the Tuileries, an invention of this nature by M. Naquet, of Ansaulliers (Oise), attracted considerable attention, as it produced straw walls of extraordinary regularity and strength.—JOHN B. CAMAS HELLA.

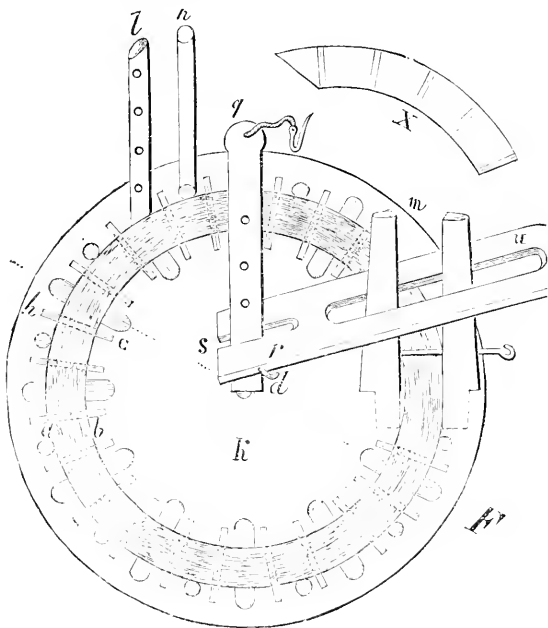

## Review.

BRITISH BEE-KEEPERS' PRACTICAL NOTE-BOOK, FOLLOWED BY RULES FOR THE GENERAL MANAGEMENT OF MOVEABLE COMB-HIVES THROUGHOUT THE YEAR. By T. W. Cowan, F.G.S., &c. (J. Huckle, Kings Langley, Herts.)

Bee-keeping is passing through a new phase. It is rapidly assuming the form of a science. It is daily becoming evident that it must be conducted more systematically and methodically than it has hitherto been. Mr. Cowan's *Practical Note-book* is published at a most opportune time; and if accurate entries are made of all the operations and observations in the apiary to which it directs attention, it may lead to the discovery of many new facts, such as the relation of the secretion of nectar in plants in regard to the weather, and the laws regulating the production of honey. The book comprises a series of tables, which have been so arranged that the bee-keeper may make the following entries:—Daily Observations; Observations during Winter; Ob-

servations respecting Queens; Queen-rearing; Number of Brood-combs, &c.; Swarms; Produce of the year; Food table; Autumnal inspection; Wintering table; Inventory of Stocks; Income and expenditure. At the end of the work are given some short rules for the general management of moveable comb-hives. Where a large number of hives are kept for profit, it will be found very desirable that accurate entries be kept; and the possessor of even a few hives will find his interest in his bees much increased by attention to the details required by this book. It is needless for us to state that the author, in compiling this work, has drawn from his own experience the requirements of the apiarist—an experience considerably enlarged by his having come in contact with the most able bee-keepers on the Continent. His work will be found a most necessary supplement to his *Guide-book*; and we trust that it will meet with as large a measure of appreciation at the hands of the public as has been meted out to that most reliable and practical work.



## Echoes from the Hives.

*Abingdon.*—My bees are still doing remarkably well. Although there has been a lot of cold rain in Abingdon for several days and N.W. winds, my bees work well between the storms; and to-day, June 9, I have taken fifteen pounds of splendid honey in glass super from one hive; and last Monday, June 2, I took a second super off another hive eight pounds; the first glass super was taken from the hive on May 26th, eight pounds; and there are two more nearly fit to come off on the hives, and I have one hive nearly forty pounds in weight of honey with large glass super on top, the super is nearly full of comb, and about half full of honey. My hives face full south. My bees have been well cared for all through the winter and do not swarm off and leave their home.—D. BRICKLAND.

*Leighton Buzzard, May 28.* I have this day taken twelve 1-lb. sections from one hive; other hives working in supers well. Had first swarm from skep on May 12. I fancy my bees are early.—SOUTH BEES.

*North Leicestershire.*—The 7th, 8th, and 9th inst. have been cold and wet and the bees pretty well confined within doors; prior to the 7th they had a good month's hard labour. Nevertheless reports are very conflicting. On the one hand, stocks abnormally strong are reported; on the other many are still said to be weak, not having recovered the bad windy weather about Easter-tide. Supplies have been very abundant from may, sycamore, trefoil, maple, daisy, and late blossoms, and there have been a few nice supers secured. The first swarm in this neighbourhood issued on May 7th from a skep hive, the first from a bar-frame on June 14th. As the bees are just beginning to flower, and the clover and limes will be ready in a fortnight, future swarms will be almost valueless; hence returning swarms and efforts at prevention are the order of the day where honey is wanted.—E. B.

*South Cornwall, June 10.*—Melancholy proof of the short supply of nectar! This morning I found drones being ejected from a skep which had been well fed, and was fairly heavy; not grubs, but fully developed, and in some cases living and moving bees. Of course examination followed, with the discovery of both worker and drone brood almost down to the floor-board, but of little honey. This is the first summer's day for weeks; and though there is but little sun the cold wind has ceased to blow, and it is close and thundery. The barometer is rising, and if the temperature continues high the numerous workers will gather supplies. At present we are just in the state we were. This time last year plenty of bees but little honey; all will now depend on the weather. Two May swarms are reported in the neighbourhood, and I have heard of three or four more during this month.—C. R. S.

*Ireland, Bray, June 5th.*—Bees are very backward for the time of year, at least a fortnight later than last year; bee-keepers only now beginning to get the bees into the supers; the weather now being so cold that they are hardly able to store any honey, only having enough for the brood; though we had a fine fortnight in May, yet we had a cold east wind almost every day. E. D'O. jun.

*County Donegal, Finn Valley.* The last ten days of May were splendid weather for bees; and the latter filled some sections in body of hive, which I transferred to top to be sealed over. The first week in June was cold and chilly, and the bees stayed in their hives, and took down all the honey from the sections in super, probably because their stores were running short. My stocks, most of which occupy nine frames, are making no preparations for swarming, which I expect will be late this year in

this district. The white clover is beginning to bloom, and if we had some weeks of fine weather we would have a good harvest. In this district very few straw skeps remain after the winter. Several persons who had flourishing apiaries two years ago have now not a single stock. I should say that at least three-fourths of the stocks in straw skeps perished during the past winter.—APICTIA, June 9.

## Queries and Replies.

QUERY No. 776.—(C. J. J.)—*Returning Swarms, Casts, &c.*—I have a strong lot of bees in a frame-hive, the stock-hive full, and the bees now busy in the sections. The bees were a last-year's early swarm, and the age of the queen unknown, except that the parent hive swarmed the preceding year, so the queen was probably hatched in 1882. If the hive swarms, could I return the swarm; and, if so, which queen should be kept? I am a novice, and should object to examine the frame-hive for the old queen, even if I were sure of finding her, of which I am uncertain. How are casts returned? *i. e.* do the bees destroy the surplus queen? When skeps are driven and united, do the bees destroy the surplus queen? if not, how is the difficulty of the second queen surmounted? *A.* The probability of your hive swarming or not depends upon the weather. In cool, showery weather, when little or no honey is coming in, bees will swarm, owing to the rapid increase of population and the scarcity of food. In fine, sunny weather, with occasional showers, when honey is coming in fast, they will continue to work in supers if sufficient room for breeding is given below. As you do not appear to be sufficiently expert to discover and capture a queen, in case of your bees swarming, either follow the plan given in our last number under 'Swarms Deserting,' in 'Useful Hints,' or return the swarm to the parent hive on the evening of the day it issues, spreading a sheet in front of the hive, and shaking out the swarm upon it. The parent hive should be wedged up a couple of inches in front to allow the bees to enter quickly. But by the latter plan the probability is that the swarm will issue again. Casts are returned in the same way. The bees will settle the matter of queens.

QUERY No. 777.—(S. L. B.)—*Returning Swarms.* In various notices about swarming I have seen it mentioned that as the owner did not wish the number of his stocks increased, the swarm was returned. Please say if this can be done; and how? Is the old queen to remain queen of the new united stock, the queen-cells having been first cut out? And will swarms, as a general rule, accept this way of cheating their instinct; and under pretext of being hived allow themselves to be replaced exactly as if they had never swarmed at all? I am specially anxious to know, as last year my supers, which were coming on well, were spoiled just at the critical moment by swarming, and never were finished. *A.* See answer to 'C. J. J.' Very much depends upon the weather and the season, but as a general rule returned swarms issue again; in fact, continue swarming out until the honey season is over. If a swarm is returned the queen-cells should be cut out previously, and in the course of a week the operation should be repeated, but we prefer to gratify the swarming impulse. Refer as above; also to the previous reference in our last issue, and you may get your supers filled and avoid increase. 2. *Queen Wasps.*—(Profiting by advice in the *Journal*,) this spring turned my attention to queen-wasps, and have 'removed' in the garden the goodly number of thirty-six. Although I know that this is a Bee Journal, and not a Wasp Journal, I should like to know if you could insert a short note on the natural history of these queens; *i. e.* a brief sketch of their lives, telling whence they come and how long they live. Do all the wasps we see in autumn in a

wasps' nest die the same autumn except the queen? And where does she live during the winter? And does she alone excavate the nest for the coming brood? And does she live through more than one season, like a queen-bee? and only once impregnated? And is there any easily accessible book giving fully their natural history, and that of the humble bee?—*A. Nilid alienum*, &c. The communities of wasps, like bees, consist of females, males or drones, and workers. The females are of two kinds,—first, the females proper, which are considerably larger than either the males or workers; secondly, there is a smaller kind of females, which, like fertile workers, only produce male or drone eggs. The females in a populous vespiary amount to several hundreds; they emerge from their pupa state towards the end of August, about the same time as the males; they fly in September and October, when they pair. Few of these females, however, survive the rigours of winter—only the strongest do so; they remain during the winter in a torpid state, till the bright spring weather revivifies them, and recalls them to renewed activity. It is in the spring that the greatest vigilance should be exercised in the destruction of queen-wasps, for each of them may become the founder of a numerous colony. As soon as revived by the warmth of spring the queen-wasp proceeds to construct a few cells, and deposits in them the eggs of working wasps. The eggs are covered with a gluten which fixes them securely to the sides of the cells. The eggs seem to require care from the time they are laid, for the queen-wasp many times in the day put their heads into the cells which contain them. The life of queen-wasps seems to be no sinecure. At first they have no helpers. They are the solitary founders of the colonies. They take the same care of their young as worker-bees in feeding the young grubs; indeed, those first hatched are entirely fed by the queens which produced them. They feed them till they are in their pupa state; but within twelve hours after they have arrived at their perfect state, the young wasps eagerly commence building cells, and proceed to assist their parents in feeding the grubs of workers and females which are by this time born. In a few weeks the colony will have received the accession of many workers and females, who without distinction apply themselves to providing food for the now numerous grubs. Even when the vespiary numbers many thousands the queen-wasp does not cease her labours, but continues to set an example of industry to the community. It is most probable that she does not survive through a second winter. Every work on entomology treats of the history of the wasp and humble bee, but we are not acquainted with any work devoted specially to them.

QUERY No. 778.—(R. R. RABY).—1. *Packing for Winter*.—Please answer the following questions in your next issue, if convenient.—1. If bees are numerous enough in September to cover nine or ten frames, may not that number be left in hive when packing for winter?—*A.* Yes, certainly. Say the end of September, or early in October. Many winter upon ten frames. 2. *Tobacco paper*.—Does tobacco paper stupefy bees?—*A.* Yes, if sufficient quantity of the smoke be given. For ordinary use brown paper is best. If you wish to stupefy bees puff-ball is generally used, but as it is thought to be injurious to the brood, it should be used only at such times as the bees are not breeding. 3. *Honey left for Bees*.—If five or six frames contain a good deal of honey when it is time to super, should some of it be extracted? or should it be all left for use of bees?—*A.* We should prefer leaving it for the bees.

QUERY No. 779.—(Q. Q. Q.).—1. *Sending Queens by Post*.—I shall have some spare young queens to send by post next week, and would thank you to say how I should pack them so as to travel safely, and also what number of attendants should be given to them, and what

kind of food?—*A.* Queens may be sent by post with a small piece of comb, about two or three inches square, in a little frame fastened in the middle of the box, and about one hundred workers, or they may be sent in a small box with only about a dozen workers. A small piece of candy is put into a recess on one side of the box and a tube filled with water, 'corked' with a sponge, on the other side. This is the way many queens were sent from Cyprus and arrived safely. If the post-office people know the contents they will refuse them, so you must pack them so as not to be discovered. 2. *Preventing Queens entering Supers*.—How can I prevent (or nearly so) the queen entering the super without using the excluder-zinc? If I leave a space of  $\frac{3}{4}$  inch between frames and sections would not the bees build comb in it?—*A.* The separators between the sections will so reduce the size of the slits as to render it difficult for the queen to enter the supers over the hive. 3. *Preventing Wasps-Moths*.—In order to prevent moths from working in slits of top bars of frames, would it do to keep the foundation within  $\frac{1}{2}$  inch of top and fill the space with ordinary putty?—*A.* Putting the slits on the tops of the frames will prevent the moths laying their eggs there. 4. *Extension of Supers*.—Is there any objection to the super extending beyond the frames over the chaff-packed sides (three inches in width)?—*A.* The only objection is the diffusion of the heat. The overlapping sections would not be likely to be entered. 5. *Treatment of Young Bees*.—I formed some nuclei recently by giving a comb of hatching brood and one of honey and pollen. As soon as the young bees hatched the bees dragged them outside, and I was obliged to remove the brood-comb so as to save the lives of the young. What was the cause of this?—*A.* If you examine the brood thrown out you would find, probably, that their wings were defective owing to partial chill, sufficient to prevent perfect development, but not to cause death in the cells. 6. *Queens from Nuclei*.—I have now one comb each in two nuclei, and they are quite easily managed, although I have read that the bees are disposed to swarm with the least interference. One of these nuclei has two queen-cells sealed over. I have read that queens reared in small nuclei are very inferior. Are they less prolific than those reared in mother-hives? Would they not do very well to put over a swarmed stock for a week or two till good queens would be reared from the queen-cells?—*A.* The bees from nuclei when without food are apt to follow the young queen when she goes forth on her wedding flight. Queens reared in nuclei or in small colonies are not so strong or good as those reared in strong stocks. The proper plan is to get them reared in strong stocks and give the ripe cells to nuclei to hatch out. 7. *Uniting Nuclei*.—How can I unite two or more nuclei when I take the queens from them?—*A.* The bees of nuclei, when done with, may, if they stand near each other, be brought together and united, leaving one queen, and strengthening by a comb or two of brood from other hives, or they may be united to any other stocks, and the few lost bees returning to the old spots disregarded.

## NOTICES TO CORRESPONDENTS & INQUIRERS.

T. CARTER.—*Mason Bees*.—The cells forwarded are those of the mason bee (*Megachile muraria*). Nests of the mason bees are often found in the angles of empty hives. They generally select for their structure an angle sheltered by a projection on the south side of a stone wall. The chief materials of the nest are grains of sand, which are glued together by a viscid saliva into masses the size of a small shot. After the walls of the cell are raised, the female deposits an egg with a supply of pollen and honey, and proceeds to the erection of a second cell, and so on until the whole number, which varies from four to eight, is completed.

The Rev. J. Lawson Sisson writes:—'In a great many of my hives (bar-frames) there are masses of the cells of these tiny bees, but I have never seen them making use of the honey-bee's cells till this year. In one hive they have filled up all the spaces between the V-shaped broad-shouldered frames of Abbott's pattern. So well mortared are they that it was difficult to move the frames. Seeing some notions of wild bees in the present number of the *J. vocal* induced me to send you the specimen. Two of the combs in same hive have cells filled in the same way. You can see the yellow pollen (in which the masons have deposited their eggs) very plainly by looking at the other side.'

MISS M.—1. *Drones-cells*.—The cappings you note are those of drone-cells; the colour of the cappings is caused by that of the pollen or bee-bread, which with wax constitutes the covering of the cells. These cappings are different from those that cover honey-cells, which are pure wax. 2. *Hatching of Virginia Queens*. It is about eight days after the swarm has departed that the first princess is hatched. 3. *Size of Virginia Queens*. The young queens when they emerge from their cells are egg-sized; when they settle down to their duties of egg-layers a change takes place in their appearance; they look more truly.

W. CORFIELD.—*Thymol*.—Thymol is not used for clearing hives, though we do not see why it should not be useful in that way. It is used as a preventive rather than a cure for foul brood. The crystals are stretched up in a muslin bag (three or four crystals of 10) and placed in one corner of the hive. It is volatile (something like camphor) and is a strong antiseptic. It is made from oil of thyme.

C. SMITH.—It will be desirable to drive the bees and transfer the combs to a bar-frame hive. Bar-frame hives are procured from any dealer in bee appliances (see advertisements). For the best mode of driving and transferring see *Modern Bee-Keeping*.

A. G. AMERSHAM.—*Feeding Systems*.—Your bees should have been fed. During the late cold, wet, inclement weather it has been impossible for swarms to build comb—or, indeed, to exist—without food, which they could not obtain from the fields. Feed upon syrup. See recipe in *Modern Bee-Keeping*. Continue feeding until the hive is filled with comb, then cease, and put on a super. You should read Mr. Cowan's book. If the season prove a good one you may obtain surplus honey towards its close. We recommend you to procure a visit from your County Expert, from whom you will obtain more practical information in half-an-hour's conversation than you gain from a long study of books.

RALPH H. COWELL.—The nearest expert to Chesham, Cheshire, is either Mr. W. B. Carr, Higher Bobington, Cheshire, or Mr. E. G. Parker, Altrincham.

W. B. J.—1. *Drones*.—The number of drones in your hive is caused by the foundation supplied. If desirable a drone-trap might be employed to reduce their number. 2. *Removing Sections*.—With the sections employed there is no difficulty in seeing the progress made by the bees in filling the sections. When full let them be removed and others supplied.

R. CAREY, *Skibbereen*.—The flower forwarded is *Linanthus Douglasii*. You will do well to cultivate it for your bees.

H. G. W. A.—Most likely the unhatched drones, being at the edges of the outside combs, got left outside the cluster one cold night, and so became chilled and died, and were thrown out.

BUSY B.—*Queen-cells on Drone Brood*.—Bees sometimes raise queen-cells on drone brood; but drones only are ever evolved therefrom. This appears to be one of the few mistakes committed by bees.

## IRISH BEE-KEEPERS' ASSOCIATION.

BY ARRANGEMENT WITH THE ROYAL AGRICULTURAL SOCIETY OF IRELAND.

### The BEE-TENT of the ASSOCIATION

WILL BE AT

#### THE CATTLE, &c. SHOW, KILKENNY.

ON JULY 2ND, 3RD, AND 4TH.

Lectures and Manipulations, at intervals, each day.

CHARLES F. KNIGHT, M.D., *B. S., &c.*

## LEICESTERSHIRE BEE-KEEPERS' ASSOCIATION.

PRIZE SCHEDULES of the LEICESTER and MELTON MOWBRAY SHOWS can be had on application to the Secretary, Mr. EDWIN BALE, WATHAM, MELTON MOWBRAY. (72)

### PURE FOUNDATION,

2s. 2d. per lb.; 5 lbs. at 2s.

COMBINATION HIVE, 24 inches long, 10 inches deep (the Cheap and Complete Hive made), price 8s.

*Illustrated Catalogue, free anywhere.*

PRIZE STRAW HIVES, price 1s. 4d.

G. STOTHARD, Welwyn, Herts. 2197

### BEES! BEES!! BEES!!!

SEVERAL more Swarms for disposal, including Pure Ligurian, Hybrid Ligurian, Holy Lands, and Black, Small Swarms for Liganiansing in Nuclei. QUEENS—Imported Ligurian, Home bred, Tested, Untested, Holy Lands (hybrid), and Blacks, from Queen whose progeny proved best honey gatherers last year. Apply for particulars to

E. WOODHAM, Abbotsley, St. Neots. 2292

LIGURIAN THREE-FRAME NUCLEI. I can spare a few more at 21s.; after June 17, 6d. each. Address Swarms, Rottlingdean, Brighton.

FOR SALE, a SMALL BEE-TENT, with Poles, &c., complete; quite new. 8 ft. long, 6½ ft. high, 2½ ft. wide; the sides are made of white net, and top of Holland. Price 30s. Address C. P. Ivy Lodge, West Molesey, Surrey.

### C. G. HARRISON & CO.,

MANUFACTURERS of every description of BEE-KEEPING APPLIANCES. Among their Specialities are Hives, 10s. 6d. each, Metal-ends, Metal Covers, Honey Extractors, Wax Extractors (new pattern), Smokers, Feeders, &c. Silver Medal, Knightsbridge; 1st and 2nd Prizes Hagley and Coventry.

HALES OWEN, WORCESTERSHIRE. (2502)

### WANTED.

LARGE QUANTITY of ENGLISH HONEY; also, a MAN TO LOOK AFTER PUBLIC EXHIBITION OF BEES, for Three Months or more, at Watering-place, West Coast. Address A. I., *Advertiser Office*, Altrincham, Cheshire.

### WIRE STAPLES, &c.

A. GOODALL & SONS, BRIGHOUSE, YORKSHIRE.

*Or from*

C. T. OVERTON, THREE BRIDGES, SUSSEX. 1963

**DR. PINE'S**

**Registered Removable Metal Frame Ends.**

*Prize Medal, B.B.K.A., 1882; and numerous other Prizes.*

BY the use of this valuable invention the making of Frames is simplified. No metal runners are required, all systems of frames are rendered interchangeable, and propolization is reduced to a minimum.

Unfortunately, as is the case with all inventions of merit, numerous substitutes are being introduced under the name of 'improvements.' But there is not one of these so-called 'improvements' which does not possess defects from which the original invention is free.

It is, therefore, absolutely necessary when ordering Hives to specify that the Frames are to be fitted with 'DR. PINE'S ENDS,' and with no others. All Hive-makers will supply Hives fitted with them, and generally without extra charge, the small cost being saved in diminished cost of labour.

Price of the Ends, 1s. per doz. or 10s. per gross.

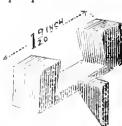

**DR. PINE'S Woven Wire Veils.**

*Prize Medal, B.B.K.A., 1879.*

Do not confine the breath, do not obstruct the sight, and cannot be blown against the face or ears.

Price 2s. 6d. each.

**DR. PINE'S BEE-KEEPERS' LOTION**

Is the acknowledged Remedy for Stings, especially for removing the subsequent inflammation. Price 1s. 6d. per bottle.

*The above Medications may be obtained from*

Messrs. NEIGHBOUR & SONS, Regent St. & Holborn, London; and from all respectable Dealers in Bee-keepers' Requisites.

*Dealers may obtain Wholesale Prices from the Inventor, Mr. F. LYON, 94 Harleyford Road, London, S.E.*

**BEE VEILS.** Improved with Wire Gauze Fronts, or with Silk Brussels Net. Post free 18 Stamps. Address B. DIXON, Papworth-Everard, St. Ives, Hunts. (59)

**CANE (PREPARED)** for making Straw Skeps. 1 lb. postal packages. Fine, 2s. 3d.; Coarse, 1s. 3d.—free. SALICYLIC ACID, 1s. per oz. post free. THYMOL, 1s. packets free. Either of the foregoing cheaper in quantity. Address J. R. W. HOLE, Tarrington, Ledbury.

**BEE HIVES and APPLIANCES**

Of the best quality, at the lowest possible price, to be obtained from

**JOHN LEAKE, JUN. BEACON STREET, LICHFIELD.**

COTTAGERS' HIVE, made of 1-inch best Pine, planed outside, contains 9 Standard Frames and Dummy, resting on Tin Runners, suitable for Bee-Shed. Price 4s.

ABBOTT'S HONEY EXTRACTOR, best make, 9s. 6d. BINGHAM SMOKER, neatly and strongly made, 3s. 6d. Other Appliances at an equally low rate. 5 per cent. discount off all Orders up to April 1st.

Send Card for PRICE LIST to

J. LEAKE, Jun., Beacon Street, Lichfield. 1873

**THOMAS B. BLOW, WELWYN, HERTS,**

Manufacturer of Bee-keeping Appliances of every Description,

And IMPORTER OF FOREIGN BEES,

BEGS to call attention to the unrivalled quality of his productions. By the aid of special power machinery he is enabled to combine moderate prices with high quality. Mere lowness of price is not so much aimed at as accurate fit and finish, all goods being adapted both for the convenience of the Bees and ease of manipulation to the Bee-keeper.

ILLUSTRATED CATALOGUE, 48 Pages, 50 Illustrations, full of interesting and useful information, Free on application.

**THE HEREFORDSHIRE SCHOOL OF APICULTURE**

SUPPLY BEES, HIVES, and everything pertaining to Modern Bee-culture. Hives made only of the best well-seasoned wood, a quantity of which is always kept ready cut and prepared for putting together.

Awarded Honourable Mention for a Hive exhibited at CORK INDUSTRIAL EXHIBITION, 1883, and First Prizes at various County Shows. Revised Catalogue for 1884.

**J. R. W. HOLE,**

(Elected to the Herefordshire B. K. A., qualified by B. B. K. A. Certificate.)

Address — TARRINGTON, LEDBURY.

**CHARLES T. OVERTON,**

First Class Export of the Sussex Bee-keepers' Association,

THREE BRIDGES, SUSSEX,

Bees to all attention of all Bee-keepers to his

NEW STOCK OF BEE-KEEPING APPLIANCES for 1884, and hopes to be favoured with their support.

Silver and Bronze Medals, and other Prizes awarded at Exeter, Knightbridge, Herts, and other Shows, for the Best Bee Hives, Bees, Smokers, Saps, Extractors, Comb Foundation, &c.

Orders may now be booked for Prime Straws, and Swarms of ENGLISH, LIGURIAN and other Foreign BEES, for early spring deliveries. Also Imperial LIGURIAN QUEENS. First consignment will arrive early in May.

**SPECIALITIES.**

The 'COWAN HIVE' and Extractors. Bingham Smokers, the best in use; Supers; Honey Racks; Comb Foundation, American 2-lb. and 1-lb. Sections; FLAT TOP STRAW HIVES, with hole in top for feeding and sapping, 2s. each; Crates of 18 1-lb. Sections for Straw Hives, 5s. each complete.

Questions on Bees and their Management answered by return of post, 3d. stamps. Send 7d. for Modern Bee-keepers, 1s. 6d. for British Bee-keepers' Guide. Catalogue free on application.

**M. G. PARKER,**

WATCHMAKER & JEWELLER,

ALTRINCHAM, KNUTSFORD, and WARRINGTON.

All kinds of Bees, Bee-Hives, & Appliances,

For Old-fashioned as well as Modern Bee-keeping.

BAR-FRAME HIVES from 4/6 each, COMB FOUNDATION, SMOKERS, FEEDERS, &c., at most reasonable prices.

With list of 35 Prizes & Medals for Bees & Appliances last year.

1st Prize for English Bees, both in 1882 and 1883.

1st Prize for Observatory Hive.

1st Prize for Best and Cheapest Cottagers' Hive, on the Movable Comb principle, not exceeding 15/.

1st Prize and Silver Medal for Best and largest Collection of Bee-Hives and Appliances for Modern Bee-keeping, including a Hive complete on the Modern System at 25/-, at the Cheshire County Bee-keepers' Association Show; also 1st Prize for largest Collection in 1882.

'MODERN BEE-KEEPING,' the Simplest and Cheapest Book. Price 6d.

Cash with Order to be sent to Altrincham. (61)

# THE BRITISH BEE JOURNAL

Communications to the Editor to be addressed 'STRANGEWAYS' PRINTING OFFICE, Tower Street, St. Martin's Lane, W.C.'

[No. 149. VOL. XII.]

JULY 1, 1884.

[PUBLISHED FORTNIGHTLY.]

## Editorial, Notices, &c.

### PHYSICIAN, HEAL THYSELF.

We publish on page 227 an editorial article on the British Bee-keepers' Association which appears in the current number of the *Beekeepers' Record*. The *Record* is the organ of the Lancashire and Cheshire Association, the *Bee Journal* not being good enough for it. It is an advantage for the British Bee-keepers' Association to have the mirror held up to it, that it may know how it looks to one of its affiliated associations; and it ought no doubt to feel grateful to the editor of the *Record* for the conscientious manner in which he has discharged the duty which he feels to be incumbent upon him of 'looking critically into its organization and conduct.' We cannot, however, commend the tone in which this article is written, nor the spirit which seems to inspire it. We were under the impression that the British Bee-keepers' Association *was* holding a Metropolitan show at the present moment in connexion with the International Health Exhibition; and this is a Show lasting for six months instead of three or four days, as formerly. We also thought that a great opportunity was offered this year to bee-keepers to meet together for friendly intercourse in the Conferences which have been arranged for the 25th and 26th of July. We may be wrong. Doubtless the writers in the *Record* are the people, and wisdom will perish with them. It has been suggested to us, however, that it may perhaps be our duty 'to look critically into the organization and conduct' of the Lancashire and Cheshire Association, and to remind its members that the holding of Shows is not the only duty of a Bee-keepers' Association. It is also the duty of its Committee to steer clear of County Courts, and to pay the prize money within a reasonable time to those who have gained such at their Shows. We might also remind them that vaulting ambition sometimes overleaps itself, and that the frog who tried to swell himself out to look as big as the bull ended, as our American friends would say, by 'bursting up.'

### THE EDUCATIONAL ACT AND APICULTURE.

The Rev. Arundell Leakey, Vicar of Acton, near Sudbury in Suffolk, deserves the thanks of all bee-keepers, both present and future, for the step which he has taken in reference to introducing the science and art of bee-keeping as an element in our National Education; and we congratulate him on

the encouraging response which he has received from the President of the Committee and Council on Education, which will be seen in p. 220. We understand that Mr. Leakey has communicated with some members of the Examination Subcommittee, and that the matter will be taken up by them in good earnest. We hope to be able to report progress after the next meeting of the General Committee, or Council, as we think it might well be called.

We have long felt the importance of inducing schoolmasters in rural districts to interest their scholars in the fascinating pursuit of the study of the bee, feeling assured that if the principles of humanity to this little insect are inculcated in the early days of childhood, it will bear rich and abundant fruit in after years.

Bee-keeping, too, is especially adapted for the schoolmaster. It takes him out into the fresh air after enduring for hours the hot atmosphere of the schoolroom. It is a recreation which has the advantage of being different from his usual work, and at the same time it allows scope for the special bent of the scholastic mind. There is just enough of science in it to give it the necessary interest to recommend it to the ordinary schoolmaster. It is exactly what is needed to bring him into relation with kindred minds, and thus in a degree to break down the irksome isolation of enforced residence in a rural village.

We feel convinced that if the schoolmaster will turn his attention to bee-keeping, it will give a fresh zest to his life, and he will, while instructing his poorer neighbours, be conferring a benefit upon them. We have the brightest hopes that this new departure will be a marked era in the history of bee-keeping; and we trust that the Subcommittee will feel the necessity of perseverance in order to obtain from Government the removal of the restrictions mentioned in Mr. Leakey's letter.

### BEE-KEEPERS' ASSOCIATIONS IN N. WALES.

ROYAL AGRICULTURAL SOCIETY, SHREWSBURY.

A meeting will be held in the Meeting Tent of the Royal Agricultural Society on the Show Ground at Shrewsbury, at 5 p.m. on Tuesday, July 15th, with a view to forming Bee-keepers' Associations for the Counties of North Wales. The meeting will be addressed by some of the leading members of the British Bee-keepers' Association, and all who are interested in improving the condition of the artisan and the agricultural labourer, whether bee-keeper

or not, are invited to attend. The Hon. George Douglas Penman, the eldest son of Lord Penrhyn, has been invited to preside over the meeting.

### COUNTY BEE-KEEPERS' ASSOCIATIONS IN SOUTH WALES.

A copy of the following letter has appeared in the newspapers in South Wales; and we are pleased to announce that it has borne fruit in the establishment of a Bee-keepers' Association for Cardiganshire:—

(To the Editor.)

May I ask you kindly to draw the attention of your readers to the importance of forming Bee-keepers' Associations for the counties of Cardiganshire and Montgomeryshire? These counties appear to be well suited for bee-keeping, and the production of honey is now becoming a national industry which should not be overlooked by those who are anxious to befriend the agricultural labourer and to enable him to make some addition to his scanty income. There is a large demand for honey in England at the present time. Messrs. Huntley and Palmer, the well-known biscuit manufacturers at Reading, require a regular supply of two tons of honey weekly; and the Rev. V. H. Moyle, the hon. sec. of the Berkshire Bee-keepers' Association, in order to supply the demand, has opened a depot for honey, for which a good market price is given. The sum of 4962*l.* was paid to foreigners during the month of April alone for honey imported into the United Kingdom. Why should this money not have been paid to our own countrymen? Every other county in South Wales will soon have its Bee-keepers' Association to bring the seller and buyer of honey together. Why should Cardiganshire or Montgomeryshire wait?

I beg to call the attention of all clergymen, schoolmasters, and gardeners to this deficiency in the institutions of these two counties; and I am quite sure that Mr. L. Oswald Lewis, the hon. sec. of the Carmarthenshire Association, will give them the benefit of his experience in forming such an association if they will only consult him.

The British Bee-keepers' Association (of which the Baroness Burdett-Goutts is the president) will also give considerable assistance to the promoters of County Bee-keepers' Associations.—I remain, sir, yours truly, HERBERT R. PEEL, late Hon. Sec. B. B. K. A., Thornton Hall, Bucks.

### PEEL TESTIMONIAL FUND.

	£	s.	d.		£	s.	d.
<i>Deronsshire.</i>				<i>Lincolnsire.</i>			
W. N. Griffin . . .	0	5	0	R. R. Godfrey . . .	2	2	0
W. Walker . . .	0	5	0	<i>Surrey.</i>			
<i>Essex.</i>				A. W. Robinson . . .	0	5	0
Rev. G. Raynor . . .	1	1	0	<i>Sussex.</i>			
<i>Hertfordshire.</i>				T. W. Cowan . . .	2	2	0
Rev. E. Bartram . . .	1	1	0	G. D. Haviland . . .	0	10	0
J. Kipling . . .	0	2	6	<i>Warricksire.</i>			
Rev. F. G. Jenyns . . .	1	1	0	J. Noble Bower . . .	0	10	0
Miss Gayton . . .	0	5	0	G. Franklin . . .	0	5	0

The above subscriptions are the amounts received and acknowledged by the Secretary of the British Bee-keepers' Association in accordance with the arrangement made at the special meeting of the Committee of the B. B. K. A. and the representatives of the County Affiliated Associations.

We regret that we are not able to give a statement of the full amount subscribed. Two applications have been made to Mr. J. P. Jackson for the list of subscribers

whose subscriptions were paid previous to the present arrangement, but it is not yet to hand. When received they will be duly acknowledged in the *B. B. J.*

The amounts collected by the Secretaries of County Associations, when remitted to the Secretary of the British Bee-keepers' Association, are entered separately in his accounts of the fund, under the name of each County Association.

### FOUL BROOD.

We are requested to say that Mr. Cheshire would feel obliged by any bee-keeper forwarding to his address, Avenue House, Acton, samples of foul brood, in order to enable him to complete his experiments in that direction.

### BLIGH COMPETITION.

We beg to remind candidates that copies of Competition Journals for the months of May and June should now be sent to the County Secretary.

### USEFUL HINTS.

By the time these lines are in the hands of our readers the honey-harvest will be in its full strength. The weather has been so favourable all through June that stocks are in fine order for gathering the nectar from the clover and lime-trees and storing in their owner's sections.

No time must be lost in putting on sections, if not already done. If they are put in the first instance on frames at the back of the brood-nest, and, when partially built out, removed, with the bees in them, to the top crates, it will cause the latter to be entered and worked in far more readily than if they were put on empty. The warmer supers are kept the better. If sections are required for sale, it will be right to feed extracted honey to hasten the completion of them; but if for exhibition, such a proceeding would not only be dishonest and contrary to the declaration which accompanies the form of entry, but would lead to disqualification.

**EXTRACTING.**—When extracted honey is wanted, hives should be set apart for its production. The greatest quantity is obtained by the doubling system. If, however, this is not adopted, two or three tough combs, if containing drone-cells all the better, should be separated from the brood-nest by excluder-zinc, and the honey extracted every few days. When the cells are beginning to be sealed it is ripe. If extracted before this stage is reached, honey is apt to ferment if kept some time. It is not advisable to extract from combs containing brood.

**SWARMS.**—When they have filled the hive with combs they should be supered.

**STOCKS** which have swarmed will be found about fifteen days afterwards to have filled the combs with honey; this should be extracted and supers put on. The emptied cells will be taken possession of by the young queen for breeding and the incoming honey deposited in the supers.

**PURCHASING STOCKS.**—Now that foundation is so cheap, it is not, as a rule, worth while to purchase stocks, as swarms become stocks in about ten days. But as opportunities sometimes offer of getting

good stocks cheaply, they may be ventured upon with care. Before admitting them to your apiary, examine carefully for disease.

**FOUL BROOD.**—If no experience of this fell destroyer has been had, its presence may be overlooked on a cursory examination, directed more especially to ascertain the presence of the queen, the strength, amount of brood, &c. The signs of it in a mild form are, some of the grubs being of a dull colour instead of white, or a few cells remaining capped while all around them the brood has hatched, and the cells been refilled with eggs. If this is noticed, remove a few of the caps with the point of a knife. If the brood is alive and healthy, all is well, but if dead, examine more closely. Chilled brood (which is not likely to be found at this time of the year) will be found in a patch or ring. Foul brood in isolated cells. If, on removing the cap, a brown slime is found, there is no doubt of the disease. Have nothing to do with the stock, or any from the same apiary, or even the same neighbourhood. The more advanced stages of the disease are more easily detected, many more cells will be found capped, and the caps smoken and perforated. The disease is even perceptible to the nose. The stench of decomposition arising is not to be mistaken.

**TREATMENT.**—If you have reason to suspect its presence, send us a few cells, protected so as not to get crushed in the post, and we will either set your mind at rest or tell you the worst. If the disease is present, lose no time in stamping it out, not only for your own sakes, but for that of your neighbours. You may cage the queen, and so prevent production of brood, and, when that already existing has hatched out, say sixteen to twenty days, or at once, without waiting, proceed as follows: In the evening, when all the bees are at home, drive the infected stock off in a skep, or shake off the bees from the combs if in a bar frame hive, and confine them in a skep or box with plenty of ventilation for at least forty-eight hours, until they have digested the honey in their sacs, and are at the point of starvation. Then treat them as a swarm, putting them in a clean hive which has been sponged over with solution of syrup containing salicylic acid, furnished with new frames filled with foundation; feed them with salicylic acid until the combs are built out. Meantime the infected hive should be burnt, hive, combs, honey, quilts, everything. It requires some courage to burn an expensive hive, but it is the safest way. Disinfection may answer, but, on the other hand, it may not; and if not the whole process must be gone through again, having wasted the hive and probably infected other hives which were previously not touched. The skep and canvas used for quarantine must be burnt. If you have many hives to treat, it would pay to have a quarantine-box made of tin or zinc, about eighteen inches by ten, by nine deep, with a lid, fitting bee-tight, of perforated zinc. Open the box, shake the bees in, close it, and stand it lid-downwards on two sticks on the bare earth. The bottom of the box should be lined with perforated zinc, to give the bees foot-

hold when it became the top in use. This box can be perfectly disinfected by filling with water and putting it on the fire to boil. The earth over which it stands is to be turned up, and so all infection is removed without the necessity of destruction, as is the case if a skep and canvas is used.

Mr. Cheshire is, as mentioned in *Journal*, p. 209, carrying on experiments with a view to treating stocks without destruction; but as this plan will not be published until August, if then, it would be as well to stamp out the disease when existing by the above method.

## ASSOCIATIONS.

### BRITISH BEE-KEEPERS' ASSOCIATION.

The Monthly Committee Meeting of the Association was held at 105 Jermyn Street on Wednesday, June 11. Present, Rev. H. R. Poel in the chair, Rev. L. Bartram, H. C. and Rev. H. Bligh, Capt. Campbell, H. Jones, J. M. Hooper, W. O. G. Glemis (treasurer), and the Secretary. The minutes of the last Meeting were read, confirmed, and signed. The statement of accounts for the month ending May 31st was also read, showing a balance in hand of 50*l.* 6*s.* 8*d.*

The Exhibition Sub-Committee reported that Mr. Hoge had secured space immediately adjoining the B. B. K. A. department at the International Health Exhibition for the purpose of exhibiting his 'preparative honey' and that at his suggestion the case containing the specimens of 'shilbut' which he exhibited by the B. B. K. A. had been removed by the Chief Superintendent, and that steps had been taken to bring the matter before the Council of the International Health Exhibition, with the result that Mr. Hoge's exhibits had been removed from the Exhibition, and the case of additional specimens had been replaced. This Committee also reported that the Conference to be held at South Kensington by the B. B. K. A. had been fixed for July 25 and 26.

Resolved, That Mr. Cheshire be requested to read a paper on 'Foul Brood and the best means of curing and preventing it,' and that Mr. O. H. Hooper be requested to read a paper on 'The Adulteration of Honey and the best means of detecting and preventing it,' and that the Hon. Secy. Burdett Coutts, President of the Association, be requested to take the chair.

Resolved, That the names of Colonel Pearson and Mr. Oswald Lewis be added to the list of judges for the Showbury Show, and that the Rev. H. R. Poel, the Rev. E. Bartram, and Mr. T. W. Cowan, be elected as Stewards of the Bee Department. Mr. Chas. N. Abbott and Mr. J. M. Hooper were unanimously elected as Judges and Examiners in the Bee Department of the Royal Counties' Show to be held at Guildford on June 21 and following days.

The Rev. George Raynor was elected to act as Judge at the Norwich Show, to be held on July 3rd.

The next Committee meeting was fixed for Wednesday, July 2nd.

CONFERENCE AND QUARTERLY MEETING AT SOUTH KENSINGTON, JULY 25th and 26th.

### Programme of Proceedings.

Friday, July 25th, 2 p.m., subject for discussion 'Foul Brood, and the best means of curing and preventing it,' to be introduced by Frank R. Cheshire, Esq., F.R.M.S. Saturday, July 26th, 11 a.m., Quarterly Meeting of the

Committee of the British Bee-keepers' Association and the representatives of County Associations.

Saturday, 2 p.m., 'The Adulteration of Honey and the best means of detecting and preventing it,' to be introduced by Otto Helmer, Esq., F.C.S., F.I.C., Analyst to the British Bee-keepers' Association.

Members desirous of attending the Conference are requested to make an early application to the Secretary, J. Huckle, Kings Langley, Herts, for tickets of admission.

#### BATH AND WEST OF ENGLAND SHOW.

This Show was held at Maidstone on June 2nd and the four following days. The weather, which for a long time previously had been dry and cold, causing much anxiety to bee-keepers as well as to farmers, underwent during the Show a decided change; and although it undoubtedly affected the receipts for admission to the Show Yard, the inconvenience which resulted from the frequent rain was cheerfully borne by the large number of visitors. The site of the Show was admirably chosen, the view from the upper part embracing some of the choicest scenery of the county of Kent. The bee-keeping Department, under the auspices of the British Bee-keepers' Association, but more immediately under the direction and management of the Kent Bee-keepers' Association, as on a former occasion, formed one of the attractions of the Show; and although many of the exhibits of honey entered were not forthcoming, the show of hives in the two classes provided, as well as the collections of apianian appliances, the Exhibition was fairly representative of the present phase of scientific bee-keeping. Some confusion was caused by the change of position involved in placing the department in the permanent building usually devoted to the Art Exhibition, instead of the site previously decided upon; but the almost constant stream of visitors testified to the great popularity to which the movement has attained. The Judges nominated by the Committee of the British Bee-keepers' Association were the Hon. and Rev. Henry Bligh, of New Hampton, Middlesex, the Rev. F. T. Scott, vicar of Harthip, near Sittingbourne, and Mr. J. M. Hooker, of Sevenoaks; but the duty, consequent upon the indisposition of the first named, devolved upon the latter two gentlemen, and it is needless to say their awards gave complete satisfaction.

In Class 1, for Observatory Hives stocked with bees, out of four entries Messrs. G. Neighbour and Son and Mr. S. J. Baldwin were the only exhibitors, and the prizes were awarded in the order named. Messrs. Neighbour's hive was very nicely finished, and contained six combs, Mr. Baldwin's having three combs only. These exhibits requiring a flight for the bees were necessarily relegated to a tent by themselves.

In Class 2, for the best Frame Hive not exceeding 15s. in value, twelve entries were made, by most of the principal manufacturers, and of these eleven were forthcoming. In judging these, as also the succeeding class, the Judges experienced very considerable difficulty, the design and workmanship generally being high class, many being perfect marvels of cheapness; in fact, the question forces itself upon the mind whether they can be produced for the money, or whether ulterior objects do not sometimes induce the exhibitor to undertake their manufacture even at a loss.

The first prize was awarded to Mr. James Lee of Seal, near Sevenoaks (formerly of Bagshot), for a capital hive, affording thorough protection from weather, fitted with metal-ended frames and provided with super rack. The second prize was awarded to Mr. James Blake of Ipswich, who has succeeded to the business so ably carried on previously by his father. The same excellence is apparent in this hive as has always characterised those turned out by Mr. Andrew Blake; and it is not too

much to say that it thoroughly deserves the award bestowed upon it. Messrs. Green and Sons of Rainham, Kent, Mr. W. F. Martin of Ringmer, Sussex, and Messrs. Dines and Son of Mutton, Essex, are selected for high commendation. The other exhibitors in this class are A. Joy of Aylesford, S. J. Baldwin, Bromley, Eley and Son, St. Neot's, R. W. Davies of Braintree, and E. C. Walton of Newark.

In Class 3, for hives for cottagers' use, price not to exceed 10s. 6d., the first prize was bestowed upon Mr. Alfred Joy for an excellent hive with rack for supering, and provided with a most comfortable quilt of thick saddle felt. This latter article is a somewhat novel one for the purpose, as, besides being very warm, the exhibitor claims for it free ventilation, without draught, for the vapours which ascend from the clustering bees. The second prize was gained by Messrs. Edey and Son, Mr. Baldwin and Messrs. Dines and Son being highly commended.

In Class 4, for the best collection, etc., Messrs. Neighbour and Son and Mr. S. J. Baldwin were the only exhibitors, the former firm gaining the premier position, and the latter second prize. These exhibits fully sustained the scientific character of the pursuit of bee-keeping, and the interest excited by them was strikingly apparent. Messrs. Neighbour's display of bee-keeping appliances was arranged in a most effective manner, and comprised many articles of elaborate design and finish, as well as innumerable articles of a more workmanlike kind. The display made by Mr. Baldwin was of a more practical aspect, almost every article, apparently, being for every-day use in the apiary.

In Class 5, for the best super of honey, ten entries were received, but three exhibits only were produced, two by the Rev. F. T. Scott and one by Mr. Joy. The former being ineligible to act as judge, Mr. John Martin, of Dunkirk, Faversham, and Mr. J. Garratt, of St. Mary Cray, were deputed to the task of judging in the honey classes. The first prize was awarded to Mr. Scott for a beautiful Stewarton super, the second prize being taken by Mr. Joy for a bell-glass super.

For the best twelve 2-lb. sections of super-honey, Mr. Sands bore off the Silver Medal of the B. B. K. A., the bronze medal going to Mr. Joy, and the certificate of merit to Mr. J. M. Hooker, the latter exhibiting honey in good preservation from last year. In the class for 1-lb. sections, the Rev. F. T. Scott gained the first prize for twelve very evenly-finished sections, Mr. Joy taking second honours—Mr. J. Solomon being highly commended. For run honey Mr. Joy received first prize, Mr. W. Seabrook being second. For the best sample of comb-foundation made in the presence of the judges, Mr. Baldwin bore away the palm, Messrs. Neighbour and Son taking the second prize.—J. GARRATT, *Secretary Kent B. K. Association.*

#### CARDIGANSHIRE BEE-KEEPERS' ASSOCIATION.

We have great hopes that an Association will soon be formed in Cardigan-shire. R. F. Gower, Esq., Castle Malgwyn, Boncath, is stirring in the matter; and we have little doubt that he will make the Cardiganshire Association a success. Will bee-keepers in the county kindly place themselves in communication with Mr. Gower?

#### MIDDLESEX BEE-KEEPERS' ASSOCIATION.

A Special General Meeting for the extension of the above Association was held on Tuesday, June 24, at 5 p.m. in the Board Room of the Royal Society for the Prevention of Cruelty to Animals, 105 Jermy Street, St. James's, the Hon. and Rev. Henry Bligh in the chair. The Chairman said the object of this meeting was



to extend as far as possible the area over which the influence of this institution might be felt, and to gain members from all parts of the county; and, in fact, to establish it as a proper County Association in affiliation with the parent body. For the information of those who were unacquainted with the affairs of the Middlesex Association, he would say that it was founded last year in consequence of a movement which took its rise in Ealing. Certainly, Middlesex, for reasons to which he would afterwards refer, had been left behind in the race of County Associations, and he thought all honour was due to the men of Ealing for taking the initiative in this matter. They had met with considerable difficulty in starting the Association. They received very little response from outside their own immediate neighbourhood, and the result was that the society had too much of a local complexion. This year they had secured the services of a new secretary, Mr. Fox Kenworthy, whose name was well known in the bee world, and having for some time acted as Secretary to the British Beekeepers' Association, and they determined to take some means for enlarging the basis on which the society rested. They had decided to invite those who lived in different parts of the county to become members of the committee, and several of the existing committees had offered to resign their places in favour of others who might be elected. Therefore the work they had in hand that day was to elect fresh members of the Committee, and also to consider some rules which had been suggested in lieu of those by which the institution was at present regulated. He thought it was hardly necessary to say anything on the importance of encouraging beekeeping. They were all converts to that opinion. He would not stop to recount the work which had been done by the British Beekeepers' Association; but he would remind them that the extension of that society's work, and its general success, were due to the organization of the system of affiliated County Associations. Mr. Peal, who had kindly come to the meeting, and would shortly address them, had worked very hard in this direction, and the result was that nearly every county of England had its Association, Middlesex he was sorry to say being very late in availing to its duties. The cause of this was easy to be traced. The British Beekeepers' Association when first founded was supported very much, and indeed carried on by Middlesex men, Mr. Abbott, Mr. Cheshire, and Mr. Hunter, being among the founders. Then the Annual Show seemed to be sufficient for all the wants of the beekeepers of Middlesex, and probably owing to these circumstances the idea of an association for Middlesex never seemed to have occurred to any one. There was a considerable district, which might still be called country in the Home County, and the object of the British Beekeepers' Association was to push beekeeping to every corner of the country. That could only be done in Middlesex by the formation of a society for the county, which would include the metropolis. The metropolis was the centre of the life of the country, the centre of its trade and wealth, and indeed of all its interests. He thought they ought not to despair of beekeeping contributing very much to the trade of the country. He believed the resources which might be developed through beekeeping would form no unimportant part of the income to be derived by our countrymen from our fields. One subject to which he hoped the new Association would direct its energies was towards the establishment of a honey market in London. Other counties were engaged in similar undertakings. A very successful honey depot had been established at Reading. Even if they succeeded in this project there would still be much left to accomplish. The Parent Association had to work up the interest in their proceedings all over the country. The counties must work up the districts, and the districts the parishes. In conclusion, he hoped to see the day when the almost

ideal vision of all true-hearted bee-keepers would be realised, namely, a country developing to the full the vast wealth contained in its past life—a result which must have an immense power for good in the homes of the cottagers and labourers of the country.

Mr. Henderson stated that all the members of the Committee of the Middlesex Association were Ealing gentlemen. As it was desirable that the committee should not have so much of a local complexion four of those gentlemen, namely, Mr. Gardiner, Mr. Loder, Mr. Powlesland, and Mr. Shadwell, had consented to retire in favour of representatives to be elected on the Committee from other parts of the county. He then announced that their resignation had been accepted.

Mr. Ross seconded the motion.

The following gentlemen were then elected on the Committee of the Association, the Hon. and Rev. H. Bligh, Dr. Bentham, Mr. H. Jonas, Mr. H. Leach, Mr. F. H. Cheshire, Mr. H. L. Mills, Mr. G. T. Harrison, Mr. C. N. Abbott, and Mr. A. Neighbour.

The suggested Rules for the government of the Association in future were then considered, and discussed, and passed.

The Rev. H. R. Peal said that it afforded him the greatest pleasure to attend this meeting, and lend the benefit of his experience to the Committee. He wished it to be understood that he did not attend there as a deputation of the British Beekeepers' Association. This he felt to be rather an advantage than otherwise, because he was consequently not under constraint, and could unburden himself freely. He was present merely as a friend of their Chairman, who had, in the course of his address, travelled over all the ground that he (the speaker) had intended to cover, and therefore there was very little left for him to say. He quite agreed with Mr. Bligh that the reason why Middlesex had been so backward was owing to the circumstance that the British Beekeepers' Association, which started in Ealing, was looked upon as doing duty for the home county. The parent Association had passed through several phases. It had fought its way into public favour, and had entered into what he considered the philanthropic and practical stage. Mr. Cheshire, who was to have been present that evening, had from time to time in past years reminded the Committee that, in the midst of their labours, they were losing sight of the most important part of their duty, that of getting at the cottager. They ought to benefit the cottager by teaching him how to keep his bees better, and improve his income by selling swarms of bees, honey, and wax. The best way of accomplishing this end was by means of County Associations, and he was delighted to say that every county in England except Westmoreland and Rutland had established institutions of this kind. During the present year they had invaded South Wales, and started Associations in Glamorgan-shire and Pembroke. They would, he was sure, be glad to hear that there was a good prospect of their cause extending in Wales. A most enthusiastic gentleman had recently been in communication with Mr. Oswald Lewis, Secretary of the Carmarthenshire Association on the subject, and he had gone to the expense of hives and other appliances from London for the purpose of popularising the cause in his district. This gentleman, they would be surprised to hear, was upwards of ninety years of age. He had also the pleasure of informing them that arrangements had been made with Mr. Jenkin, of the Royal Agricultural Society, the annual show of which would be held at Shrewsbury this year, for the meeting of North Wales bee-keepers on the 15th of July next (the second day of the Show) in one of the Society's large tents. The object of the meeting would be to promote the formation of Associations throughout North Wales. He trusted that these facts would act as an incentive to Middlesex. There were several districts in Middlesex, which, he thought, if

properly worked, would give a good account of themselves, such places as Barnet, Finchley, South Mimms, Stanmore, Uxbridge, Ealing, Southall, Hanwell, Staines, and Hampton. He congratulated them on the prospects of success which awaited them, taking into account the immense number of wealthy residents within the area of their proceedings. No other County Association had the advantage of a Metropolis like London wherein to canvas for subscriptions. He recommended the Secretary to lay before the Lord Mayor and Common Council the claims of the Association; also to try and enlist the support of the clergy of all denominations, from the Archbishop of Canterbury to General Booth, or Messrs. Moody and Sankey. If this course were taken, the good results accruing therefrom would not only benefit the Middlesex Association, but do good to the cause everywhere. The noblemen resident in London also had estates in the country, and they would probably be induced to support Associations established in their own counties, if their interest were once awakened by the Secretary's appeal for aid. He also suggested that the Middlesex Association should endeavour to hold its own honey market and Annual Show. If they could be relied on to do this, the British Bee-keepers' Association would be relieved of an immense burden on their finances, which was almost more than they could bear. It would set the parent body free to occupy the *vide* which he thought they were best fitted to undertake, namely, the education of the masses in the art and science of bee-keeping by the publication of literature on the subject; and the promotion of scientific experiments in relation to bees, their food and management, &c., could then also be undertaken in earnest. Only the other day a gentleman had suggested to Mr. Mundeila, the President of the Committee of Council on Education, the desirability of teaching the art of bee-keeping in the elementary schools of this country. Contrary to general expectation, this request had met with an encouraging response. In the event of this project taking effect, it would fall to the lot of the British Bee-keepers' Association to prepare graduated manuals for the use of the children—a task of importance, and necessitating considerable care. He hoped they would direct their attention specially to the establishment of a honey market, and quoted Mr. Moyle's experiment at Reading, which had been attended with so much success. Mr. Moyle could now obtain more honey than he was able to dispose of at Reading, and he had proposed to use Columbia Market for the purpose of getting rid of it, the Baroness Bardett-Coutts having kindly offered the market for such sales. In concluding his remarks, Mr. Peel said that he was sincerely interested in the success of that institution, and he prophesied great results for bee-keeping if the Association were established on a firm basis. Any assistance he could give by way of advice or attendance at special meetings would be always cheerfully rendered.

The Chairman proposed, Dr. Benthall seconded, and Mr. Fox Kenworthy supported, a vote of thanks to the Rev. H. R. Peel for his kind attendance and assistance at the meeting, which was appropriately acknowledged.

Mr. Dean proposed, and Mr. Leach seconded, a vote of thanks to the Chairman, who briefly responded thereto, and the proceedings terminated.

#### BEE-TEXT ENGAGEMENTS FOR JULY.

##### ESSEX BEE-KEEPERS' ASSOCIATION.

- July 3.—Brentwood Horticultural Society.
- July 9.—Tollshunt D'Arcy Cottage Garden Society.
- July 10.—Braintree Horticultural Society.
- July 16.—Maldon Horticultural Society.
- July 23.—Springfield Cottage Garden Show.
- July 22.—Radwinter Horticultural Society.

##### KENT BEE-KEEPERS' ASSOCIATION.

- July 4. Tunbridge Wells Horticultural Show (Annual Exhibition K. B. K. A.).
- July 9, 10. Lee, Lewisham, and Blackheath Horticultural Show.
- July 17. Cranbrook Horticultural Show.
- July 22. Dartford Horticultural Show.
- July 23. Hawkhurst Horticultural Show.
- July 29. Ash and District Horticultural Show.
- July 30. Ashford Horticultural Show.

##### WARWICKSHIRE.

- July 23.—Rugby.
- July 26.—Hall Green.
- July 29.—Hagley.

##### WORCESTERSHIRE BEE-KEEPERS' ASSOCIATION.

- July 17.—Malvern Rose Show.
- July 23.—Redditch Horticultural Show.
- July 26.—Kidderminster Horticultural Show.
- July 29, 30, 31.—Worcestershire Agricultural Society's Show at Pershore.

## Correspondence.

\* \* All Correspondents forwarding Letters for insertion in the Journal, Reports of Associations, Shows, Meetings, Echoes from the Hives, Queries, &c., are requested to direct their communications to 'The EDITOR of the "British Bee Journal," c/o Messrs. Strangeways & Sons, Tower Street, Upper St. Martin's Lane, W.C.'

#### OUR HONEY IMPORTS.

The value of honey imported into the United Kingdom during the month of May amounted to 524*l*. [From a private return sent by the Principal Statistical Office, H.M. Customs, to E. H. Bellairs, Esq., Wingfield, Christchurch.]

#### THE EDUCATIONAL ACT AND APICULTURE.

I have long thought that the Educational Act was not doing as much for the child of the peasant as for that of the town artisan, for though the curriculum is the same for both the advantage reaped must vary with the means each has of availing himself of the proffered instruction.

The necessities of the rural home generally forbid the rustic scholar staying an hour longer than the law actually demands, and those extra branches of knowledge taught under Schedule IV. are benefits only for those who can extend the time of tuition beyond that actually necessary to satisfy the attendance officer. Should, however, the labourer's child happen to be able to remain at school the subjects taught are not those which will be of use to him in his career of husbandman, and to reap any tangible benefit from what are sometimes termed 'extra subjects' he must forsake his father's calling and migrate to the town.

With a view to remedying in some degree this state of things I wrote to the President of the Educational Department, and asked him to admit scientific apiculture as a subject which should be taught and be recognised by the Act; and it was with true satisfaction that I received a reply that bee-keeping might be taken as a specific subject and earn grant under Schedule IV., subject to certain conditions set forth in the correspondence I enclose for publication.

My primary object, however, in asking you to publish this correspondence is to enable others to do what in my own parochial schools I cannot do, for though our master is a bee enthusiast, and an expert in the highest sense of the word, and at present an exhibitor in the bee-section of the Health Exhibition in London, we have no children whom parents can afford to leave at school long enough to come under Schedule IV. Hence we have no

scholars who are of standing to be taught bee-culture, and thus earn grant, but I cannot help thinking this may not be the case in all rural schools.

It was my intention to set about drawing up a text-book for use in schools, adapted to a progressive scheme extending over three years' instruction, the first year's part suited to the fifth standard attainments, and the last part touching upon the fertilisation of flowers by insects, and including elementary entomology so far as bees were concerned. However, on reflection, it has occurred to me that it would be best, through your medium, to ask the British Bee-keepers' Association to publish such a book on the lines of the *Hand-book for Cottagers*, as such a manual would carry more weight and be better received, and, consequently, better further the cause of bee-keeping than a manual drawn up by a private individual. I feel how serious a difficulty to the usefulness of the concession made to me by Mr. Mundella is this limitation of the IV. Schedule, but I have strong hopes that if the subject be taken up by those who have the labourers' well-being at heart, and a belief in the possible development of bee-culture, that the Department, which has shown such honest desire to serve the people by the Educational Act, will allow it to be taken as an 'extra subject' capable of earning grant, and subject to no further conditions than sowing and tending-sofa. The fact that the Government now recognise the subject at all as one which may be taken in any school in Great Britain, and upon a proficient knowledge of which grant may be earned, is already a success upon which we may congratulate ourselves, and a long step in the right direction.—**ARNOLD LEAKEY, Acton Vicarage, Sudbury, Suffolk, June 12th.**

Copy.

To the Right Honorable A. J. Mundella.

SIR,—A great admirer of your educational measures, I take the liberty of writing to ask you whether the department of which you are the head will allow our parochial schools to take as an 'extra subject' a branch of entomology instead of the whole subject, viz., practical scientific bee-keeping, the natural history of the honey bee, and the fertilisation of flowers by insects generally, and by the domestic bee specially? The government of more than one German State, I understand, makes the subject compulsory in rural districts.

The great liberal gift of schools to the country would confer one more national benefit if it eradicated the superstitions concerning bees, and paved the way towards the development of resources lying absolutely idle. We have every convenience at hand, and are surrounded by tracts of clover land which would render the knowledge a source of wealth to the future peasant. Very faithfully yours, **ARNOLD LEAKEY, Vicar of Acton, Treasurer and Correspondent of the Acton Parochial Schools, Acton Vicarage, Sudbury, Suffolk, 14th Feb., 1884.**

To the Rev. A. Leakey, Acton Vicarage, Sudbury.

REV. SIR,—I have the honour to acknowledge the receipt of your letter of the 14th inst.

I am directed to state that if you can draw up a graduated scheme for teaching the subject your name, and obtain H.M. Inspector's approval of it, it may be taken as a specific subject under Schedule IV.

I have the honour to be, Rev. Sir, your obedient servant, **F. T. PALGRAVE, Education Department, 20th Feb., 1884.**

To H. W. Cloughton, Esq., H.M. Inspector of Schools.

DEAR MR. CLOUGHTON, As you know the question of scientific and profitable bee-keeping is one in which I take a great interest; by lecturing and by practical demonstration I have done what I could to forward the science among agriculturists and labourers. Mr. Clark, our schoolmaster, was one of my first disciples; he is an enthusiast, and exceedingly well versed in the subject. It struck me that the Department would allow scientific

bee-keeping (as is done abroad) to be taught in the schools, and allow Government grant on the subject.

I append a letter from the Department, which, as you see, sanctions the plan provided you add your consent. I need hardly say I trust you will see no objection to a plan which will be ultimately an immense boon to the future peasant by adding to his scanty resources and dispelling the many superstitions respecting the profitable and proverbially industrious insect. With kind regards, very faithfully yours, **ARNOLD LEAKEY, Acton Vicarage, Sudbury, Suffolk.**

To the Rev. A. Leakey.

DEAR MR. LEAKEY,—The Educational Department having sanctioned the subject of 'bee-keeping,' it only remains for me to approve the graduated scheme for teaching the subject. I would only remind you that the scheme must be progressive, and extend over three years. The first year's part must be adapted to Fifth Standard children, *i. e.* of eleven or twelve years of age. Wishing you success, I remain, yours truly, **H. W. CLOUGHTON, Feb. 27th, 1884.**

#### EXTRACTION OF BEESWAX.

This subject, which has very opportunely been brought up by 'R. E. C.' in the *Bee Journal* and answered in the current number by Mr. R. R. Godfrey, is of so great interest and importance to bee-keepers generally, that I make no apology for continuing the subject in the belief that the best available process, as practised a century ago, is not only still the best process, but has been lost sight of, so far as I am acquainted, in all the modern works on bee-keeping. This is the more remarkable when we consider the intolerable amount of trouble and 'mess' usually gone through in the process of obtaining two or three pounds of wax. Whoever has once seen the marvelous *charm* wrought by a few drops of sulphuric acid, or nitric acid (*ayuga fortis*) in clarifying beeswax, must needs wonder that its use is not more generally known; and I cannot do better than send you a verbatim copy of the process as described by John Keys, in his book, *The Practical Bee-Master*, and published December 6th, 1789. This writer, perhaps better known as the author of *The Antient Bee-Master's Farewell*, published sixteen years later, will always take high rank as a 'Father of bee-keeping,' and it is not a little remarkable, that we should not have advanced, but rather retrograded, in a process which he professed to have himself invented more than a hundred years ago. **E. H. BELLARS, Hingfield, Christchurch.**

#### PROCESS THE SECOND.

To extract marketable wax from the combs by a single operation, without either straining or pressure.

Take an earthenware vessel, much narrower at the bottom than at the top; put therein a quart of water, and one ounce of single *ayuga fortis*, or the like proportion for larger or lesser quantities; stir them well together, and then put in so many good wax combs, as when melted, will reach within a finger's length of the top of the pan; set it on a clear but strong fire, and as soon as it begins to melt, stir it about, and so continue until it boils, and even longer if the combs be not thoroughly melted; remove it then from the fire, and let it stand until it be cold. The wax will be in a cake at the top, and the impurities underneath it. There will be two sorts of impurities; the lowest will be almost entirely dross; this is to be taken off by itself, and is of no value; the next will be a layer of dross, but with some wax intermixed; this also is to be taken off, so as to leave the cake pure and reserved by itself, as also any foulness that may be on the top; both which may be refined along with more combs the next boiling. Old combs that have wax in them, or other refuse that has been pressed but yet contain a considerable portion of wax, may be thus treated and will yield as fine yellow wax as the best combs, provided the combs or refuse have been previously pressed down and kept in a close tub or vessel in a house for five or six weeks,

which will occasion the impurities to ferment and rot (the wax will not), and thereby disengage the parts and dispose them more aptly for separation.

### WAX EXTRACTOR.

We forward an electrotype of a wax extractor, and think from its simplicity and handiness it will relieve a

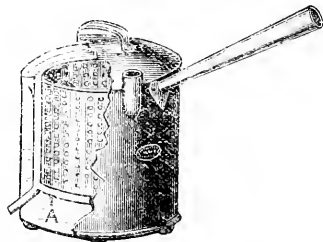

long-felt want. The mode of using it is as follows. Nearly fill the outer chamber A with water, fill the perforated basket with useless comb, &c., put the lid on and place it on the fire; the steam is allowed to escape through suitable holes at top of the inner chamber, which are partially covered (as shown on left side of engraving). To prevent any water being carried over with the steam, the wax is drawn off from the pipe at bottom; and as the lid and basket can be connected at will there is practically only one moving part, therefore the work of extracting may be carried on continuously without removing the boiler from the fire. A water gauge is fixed to large sizes, it is admirably suited for straining honey and for use as a capping can. C. G. HARRISON & CO., Coombe Wood, Hales Owen, June 25th.

### THE ITALIAN BEE.

Having for many years been an ardent admirer of *Apis Ligustica*, and as several bee-keeping friends, in the pages of the *Journal*, have questioned their usefulness, it resolves itself into a matter of fact how far individual experience of practical apiarists justifies the praise that has at various times been lavished upon them. I use the term 'practical apiarists' for the simple reason that a great many who rush into bee-keeping are far from practical, and in the hands of such persons no kind of bees or any variety of hives ever will give satisfaction, for they are continually pulling their hives to pieces just to see how the queen is getting on, until their bees become so irritable that they sting every one who ventures near them. Talk of the coming bee, Italians are eminently the coming bees, for under such treatment they come right at you,—and you, why you are generally going.

The first point I urge in favour of the Ligurian is its beauty, and if there is any truth in the old adage 'a thing of beauty is a joy for ever'—the Italian bee can win and hold it, for nothing is so beautiful as a swarm of Italian bees hanging from a branch, looking almost as transparent as amber in a mid-summer sunlight. Many years ago I was tempted by the glowing accounts of those golden bees to purchase a swarm, which duly arrived packed in a wash-tub, and very golden they were (in cost); however, I set to work to make the most of them. At that time I was the happy possessor of nine straw skeps, all about one size. I selected one with the combs half way down, and drove the blacks, and added them to a similar hive of English bees in the adjoining hive, placing the Ligurians in the hive from which I had driven the black bees.

Now for my first experience of the new race: in three weeks, or thereabouts, the Italians had built their combs down to the floor-board, and shortly after swarmed. So satisfied was I, that I ligurianised eight out of the nine hives; and never in all those years have I been out of Ligurian and black bees, and have had no cause to change or modify the opinion I then formed. The time came when I adopted the moveable frame-hive, and then came real knowledge of apiarian matters, and since then I have had Ligurian queens from Mr. C. N. Abbott and other dealers, and have sometimes found them vary greatly in colour, but the worker progeny, as a rule, were first-class, and I have had beautiful banded workers from a queen that was quite as dark as any British majesty.

Now for a few of the points upon which they will beat the Britons hollow. First, and worst, they will plant more stings to the square inch in shorter time than any hive of English bees; i.e., when thoroughly aroused. Handle them gently, and you will not have much cause to complain, except in hot weather, when honey is abundant; at which time their sentinel bees are so quick that they come like darts, and so alert are they that no black bee is allowed to enter their hive; while, on the contrary, Italians fraternise freely with black hives. They can better defend themselves against wasps and hornets, and are never subject to attacks of wax-moth; they seek them out and quickly destroy all moths and larvae. They are quicker in their flight than the blacks. Watch a hive of each race in an approaching thunder-storm; why, the Italians are all home in a body, so much so as to sometimes block up the entrance to their hive in their hurry to obtain shelter, while the English bees come home more leisurely, nothing to hurry John Bull. This alone proves them to be quicker on the wing, no mean advantage when it comes to honey-gathering.

Next they have longer tongues than Britons, so that they can gather honey where our blacks cannot. Any one can convince himself of this by bending a piece of wire gauze to a wedge shape; smear the top side with honey, and place it over the feed-hole of a black stock; then mark where the honey is cleared off. Now place it upon the Italians, and see if they do not clean it further up. Then as to honey-gathering, if it is to be had they will get it, and woe to the small black stock that attempts to rob, and amongst the slain very few yellow jackets will be found. On the contrary, a small stock of Italians defend themselves so vigorously that I have never yet seen them robbed.

Then take a glance at the interior of a Ligurian hive; see the splendid sheets of brood, often from top to bottom, speaking volumes as to the prolificness of the queens. This point, then, disparagers do not deny. See the inconsistency of their argument, for all bee-keepers are agreed that large bodies of workers are the object and aim for successful honey-gathering. Let me quote a case from my own experience. Some seven years ago, in working a very large (Abbott's Standard) hive of sixteen frames, pure Ligurians, I had four large swarms from it, and each was placed in ten Standard frame-hives, and in a few weeks were sheets of worker brood in every frame. Meanwhile, just over the hedge, a twenty-seven-acre field of beans came into bloom, and in a very short time every sheet of brood gave place to one of honey. I took one and placed it in the hands of an engineering friend, saying, 'How much will that weigh?' His reply was, 'A stone at least.'

Now mark: there was one good stock of Italians gave four natural swarms which filled from top to bottom four Standard hives of ten frames each. Now, will any bee-keeper deny their honey-gathering capabilities? I must say in all fairness that the stock hive was rather thin of bees. This question of their honey-gathering abilities is the one most questioned. I have often placed

in competition in my own apiary a hive of blacks and a hive of Ligurians with varying success—mostly in favour of the foreigner; and in the same tests with a first cross with our English bee. I never had another that could give me under the same conditions the same returns. Let any one just glance at the recent article, 'Four Years in a Bee-house, in the *British Bee Journal*, for April 15th, 1884, and examine the tabulated yield from various stocks; the evidence is in favour of the Ligurian hybrids. Down to last year my experience has been the same; a small lot of half breeds gave me 16 lbs. super of white clover honey, and other 16 lbs. super from the heather, beside a body box full from top to bottom. Writers in the *Journal* speak of them as excellent for swarming, but no honey; in a good district they will fill every cell with honey as fast as the young bees hatch out, until the queen is contracted to a brooding space no larger than a hand.

Now come to the question of testing them. This is not so easy as it used to be. In conversation with an old bee friend a few days ago he said, 'I have got a bee that gives me more swarms and more honey than ever any kind did before.' He had no knowledge of Ligurians. When I came to see his bees, they were a well-marked cross from a Ligurian. I have kept the first cross from Ligurian queens, and first crosses from Ligurian drones and English queens, and much prefer the former. The greatest objection is their irritability, fully justifying the Scotch apianist's opinion: 'A man, but this tangle devilish.'

Another advantage which they possess over their English majesties is their brighter colour, enabling any one engaged in searching for her majesty to at once find her. This of itself is no mean advantage, as those engaged in queen-raising and artificial swarming can testify. If there is a breach in your garden hedge which tempts small boys to explore and taste your ripe fruit, just shake up a half-dozen stock, place it near the trespass, and every one will give it a wide berth. Even a dog on a hot day will pass by on the other side, and then when it comes to rubbing, the Italian are always first at the feast and the last to leave. W. CURRIE.

#### STANDARD SECTIONS.

Instead of the Committee of the B. B. K. A. fixing a standard section, would it not be better to certify that all sections of a certain size shall be called or known by a certain number? For instance, say 6 $\frac{1}{2}$ " x 4" No. 1; 4 $\frac{1}{2}$ " x 4" No. 2, and so on. It would then only be necessary for bee-keepers to say 'I want No. 1,' Standard sections, or have No. 1 Standard sections of honey to sell; and the purchaser would know what he was buying. As to whether they would 'Standard' a number to a measure not a multiple of the Standard frame (inside) I leave to them; I throw out a hint that may be taken for what it is worth. S. F. CLETON, *Harleston*.

#### PLACING SWARM IN A BAR-FRAME HIVE.

I was asked by a friend the other day, how to get a swarm into a bar-frame hive. Perhaps some of your readers may find my plan simple. I remove the bottom board, and keep the top screwed on. I gather the swarm in a straw skep, and when the bees are settled down, I turn the skep upside down in a pail and stand the hive on the upturned bottom of the skep, and the bees very soon find their way up into the hive; at evening the bottom board can very easily be screwed on. J. WILKINSON, *Brimcombe Vicarage, Stroud*.

#### THE QUEEN AND THE BEES.

Mr. John Burroughs, one of the most delightful of American essayists, in his book *Loaves and Wild Honey* is responsible for the following: 'Huber relates that when the old queen is restrained in her movements by

the workers, and prevented from destroying the young queens in their cells, she assumes a peculiar attitude and utters a note that strikes every bee motionless, and makes every head bow; while this sound lasts not a bee stirs, but all look abashed and humbled, yet whether the emotion is one of fear, or reverence, or of sympathy with the distress of the queen mother, is hard to determine. The moment it ceases and she advances again towards the royal cells, the bees bite, and pull, and insult her as before.' Is this poetry or fact?—R. J. P., *Wellington, Salop*.

The note to which Huber alludes in the above passage is the well-known *piping*, which may generally be heard on the evening preceding the issue of a second swarm or cast. It proceeds from the young queen at liberty in the hive, eager to demolish her rival struggling to emerge from her cell, but restrained by the bees. The note is, doubtless, one of anger. The queen is the servant or slave of the hive, and is, by no means, a free agent. Even in the matter of swarming she is often compelled to leave the hive; and after the bees have formed a cluster on an adjoining tree, we have seen her dragged out by the worker-bees *adens colosus*, and guided to the swarm.

#### WORKERS IN QUEEN-CELLS.

I sent you with this a queen-cell, which you will see has had a queen hatched from it, and a worker has entered it to clean it out; the bees have closed the hole with the wax in it. I send it to show that the experience of one of your correspondents has been repeated. I also send a worker, imprisoned apparently when attending the larvae of a queen by the hole being partly closed. I thought that finding these cells in two separate hives this morning within a few minutes of each other sufficiently remarkable to warrant my forwarding them to you, to use or not in any way you wish.—ALFRED J. CLARKE, 29 *Abchurch Lane, St. Ethel's, Oxford, June 21*.

We are obliged to our correspondent for forwarding the queen cells; it is not an uncommon experience with bee-keepers to find workers thus enclosed in queen-cells.

#### BEES AND TARES.

What part in the life of many of nature do these nectaria play which are placed on the leaves, stipules, or parts of a plant other than the flower? I have been led to these thoughts by observing my bees busily gathering from tares. For a long time I could not discover the source of attraction. When first noticed, early in April, the tares were but two or three inches high, and not a blossom of any kind was to be seen among them. The field was alive with bees, and I spent some time on several occasions watching them; up one plant, down another, seldom taking wing, actively inserting the tongue among the young unfurled leaves, and diligently inspecting the point of juncture between leaf and stem. But for what? I gathered plants and examined on the spot; took others home and examined with a lens; but all to no purpose. No aphides, no honey dew, nothing could I light upon to explain the matter.

Time passed; the north-east wind got and held possession for some three weeks, destroying bees by thousands within the limits of my garden alone. Then came a spell of better weather, and bees were back at the tares again, but what a contrast with regard to numbers! It was now quite a difficult matter to make observations on account of the scarcity of bees, while in the early part of April they were in such abundance. All through May the weather here continued most unsatisfactory, but with care I worked my stocks up again, and the visitors to the tares increased at a similar ratio, so that by the end of the month the field on each fine day once more resounded with the hum of busy bees, as it had done six weeks before. By this time, too, the tares

had commenced to bloom, and were a foot or more in height.

On returning from church on 1st of June I noticed that the bees were flying in great numbers in the direction of the tare-field, so in the afternoon I strolled there too, and was rewarded for my trouble. The bees were more systematic in their movements; there was an absence of that restlessness as if searching for something that I had observed earlier in the year, and on alighting at once stationed themselves on the stem beneath a leaf. Thus directed I took a plant in my hand, and saw for the first time the little purple pit on the stipule. Holding it up, the concave underside reflected the sun to my eye, and applying my finger it communicated a stickiness and a perceptible sweetness to my tongue.

Here, then, was a solution to the mystery,—a honey-gland placed on each stipule at the base of the leaf, apparently quite unconnected with the fertility of the plant. There are similar spots on the stipules of field beans, and it is said bees gather from them, but I have failed to detect them doing so. There are also little glands on each side the midrib near the base of laurel-leaves, which I know are visited by bees, and probably it only requires careful observation to reveal them on many plants. As far as the tare is concerned, if the honey yielded by these glands is as good as it is plentiful, *Vicia sativa* must find a place in the list of valuable honey-plants.—THOMAS H. HARRIS, *Kingswirth, June 5th.*

[Reference to previous volume will show that bee-keepers have not been unobservant of the existence of honey-glands at the base of laurel-leaves.]

#### DEEP v. SHALLOW FRAMES. SECTIONS.

On page 200 Mr. Hewitt takes objection to my recommending the Swiss bee-keepers to use the Dadant hive for producing sections in preference to the Layens, which is a much deeper one; and asks me to explain why I prefer a shallow frame. The question has been so thoroughly discussed as to deep v. shallow frames that I should be wasting valuable space by going over it all again. Advanced bee-keepers, both in England and America, are almost unanimous in their agreement that sections are much more quickly worked over shallow frames, and the Committee appointed by the British Bee-keepers' Association were unanimous in their adoption of the present Standard. The Stewarton hive cannot be compared to the Layens; the one is an octagon 15 in. by 14 to 18 deep, the other is a hive whose internal dimensions are 30½ in. in length, 12½ in. in width, and 16½ in. in depth.

In telling the Swiss bee-keepers that the sections usually used were 4½ by 4½, and 6½ by 5½, I stated facts, and if Mr. Hewitt visits the exhibition he will see nine out of ten sections exhibited of these sizes. The reason they are so common is that they were the first introduced from America, and have since been generally adopted. No doubt when the Committee of the B. B. K. A. take into consideration the advisability of adopting a standard section they will also take into consideration Mr. Hewitt's remarks as to the commercial import of adopting another size.—THOS. WM. COWAN.

#### SWARMING IN INACCESSIBLE PLACES.

How marvellously obstinate bees can be is often made manifest if we try to dislodge them from the site of their selected bough. Sweep off the cluster as often as you please, but return to it they will. A swarm of mine—the second from a stock skep this season—settled on a main limb of a high elm—so high that ladders were useless. After many devices had been tried, and the bulk of the bough had been broken off, a small string was tossed over the stump by means of a bit of the tied to it, and a long cart-rope was made to follow. On this a bucket was hauled up under the cluster, and a good

shake secured, time after time, a few handfuls, which were successively emptied into a hive. But it was 'no go,' we failed to get the queen. Determined not to lose the bees, I then hauled up a bucket of smoking brown-paper and wet hay, and eventually saw the whole lot crowd back into the parent hive. They settled on that bough about 11 a.m. on Wednesday, June 4, and were not dislodged till 11 a.m. on the following day. The weather was at first fine. Then came a heavy storm of rain, but the bees were on the under side of the big bough and would not budge, although it rained for hours.—J. LUKIN, *Weekford, Essex.*

#### TITS AND BEES.

Having read the remarks on p. 209 on 'Blue Tits,' I think there is some mistake about the bird. Probably there is no one who has taken more interest in these birds than I have; they are constant residents in my garden, building and roosting in all sorts of odd appliances, such as old boots, teapots, meat-tins, cigar boxes, &c.; and I could at any time destroy them without the use of powder-shot, but I believe they do on the whole a great deal more good than harm. Whether they are better beloved for the treatment they get I can't say, but I can certainly say that I have never yet been able to discover that they kill bees. The great tit (*Parus major*), locally known as the Tom Collier, picks up exactly, as described by Mr. W. Crisp, all dead bees lying about in the winter and spring, when insects are scarce. The blue-tit, commonly called the Tom-tit (*Parus corulens*), I have never once seen take bees either dead or alive, although I am never without some. I have had four-and-twenty young ones reared in an old teapot in two nests within a few feet of my hives; and great as the craving of young birds is, and anxious as the parents are to satisfy them, the bees escaped, while thousands of caterpillars from the surrounding fruit-trees were brought home and eagerly devoured, the nest or home being so situated that I could see exactly what was going on from my bowser without being seen by the birds.—J. HAY, *The Wren's Nest, Astwood Bank, Worcestershire.*

#### QUEEN WASPS.

I have read with much interest the reply to Query No. 777 on the habits of wasps; and although this is not a Wasp Journal, the subject is so intimately connected with bee-keeping that it may very profitably be referred to. I have always taken great interest in wasps, and for ingenuity, industry, and perseverance they surpass bees; and if I may be allowed to be considered a bit Irish without offence, I commenced bee-keeping with a stock of wasps some five-and-thirty years ago. Having got hold of my granny's lantern, which had three sides glazed, I put in a stock, or nest, and in this observatory hive and its inmates I took delight. Last year I improved upon this, and had some beautiful specimens of nests under bell-glass sumps, which were exhibited with their living—but of course securely imprisoned—inmates, with wasps' nests in all stages, at some of our local horticultural shows in the bee department, and they certainly proved a very attractive and interesting corner.

Some part of the replies on p. 212 is new to me, and would, I think, bear investigation; but it would unduly extend the subject probably, while some of the questions asked were not answered. For instance, 'Where do queens live during the winter?' The most favourite place I have found is under the straw hackles on skeps; I have taken scores from them. They also creep under the thatch of hay or corn stacks, and in the thatch of cottages. The question was asked, 'If queens alone excavate the nest for the coming brood?' Queens excavate the holes until the young working wasps, which appear in the first week of June, are able to relieve the

queen. I have several nests of this season, and I know of others which I can take at any time, before they trouble my bees in autumn.—J. H. AM.

### SCOUTS AND SWARMING.

The following may be interesting. For some three weeks a large empty hive, furnished with frames of spare comb, has been quite actively visited by bees, and so much that I have since examined, thinking some small swarm had located there. This afternoon, about 4 o'clock, a large swarm left a cottager's garden, a first swarm from strong stock in straw skep. The owner saw them swarm out, rise direct up, and cross towards my orchard. Quickly following, he kept them in view, and several others also; they came direct down to the hive, and poured a continuous stream into it, and most certainly never clustered. Indeed, they more resembled a comet, for the queen appeared first with a primely procession. I can hardly give you exact dimensions of the swarm, but as far as I can judge, they cover six of Abbott's large Standard frames crowded. The weather is most delightful here, and bees doing splendidly.—W. E. CLARK.

### FUMES FOR SMOKER.

The black fungus which infests wine-cellar, and is mentioned by Mr. Slade in your last number (p. 207) as being a good material to use in the smoker, is known to the naturalist under the name of *Rhizidium cellare*. The fumes of it have the property of stupefying bees, but they are said to soil the honey-comb. The large puffball fungus, *Lycoperdon giganteum*, when dried and ignited like tinder has also been used to subdue bees, though I cannot speak from a personal knowledge of its use; still, I can adduce another well-known substance, namely, Amadou, familiar to the votaries of Neotoma; this is a fungus of striking character and manifold use; the *Polyporus fomentarius*. I have found this to admirably serve the purposes of the bee-master; and further, unlike the *R. cellare*, is fit to carry in your pocket—very clean, and nice to handle. It can be got at Leichter's and Barbe's, artists' colourmen, bottom of Regent Street. I have got a good sized piece, about a foot and a half long, for a shilling or so. It is used by French artists, chiefly for Encaustic drawing (*Encaustic* being the French for willow charcoal). It is safer to ask for it as Amadou for the Encaustic process than by its scientific name as *P. fomentarius*. *Cela va sans dire*. But, in fact, all touchwood can be made to produce an indifferently good bee-smoking fume by drying and a little preparation; since rotten wood is itself nothing more than wood-tissue, dead, and interlaced, disorganized, and destroyed by an enemy—the Mycelium, or delicate threads of a common fungus.—F. G. S., *Churchdown Vicarage, Member of the Gloucestershire Beekeepers' Association, June 18*.

### CYPRIAN AND SYRIAN BEES.

From the Mount Lebanon Apiary.

When I left Syria in the fall of 1882 for Athens, Greece, the Mount Lebanon Apiary consisted of some fifty-eight stocks of bees, forty of them in eleven frame-hives, and the rest in six frame-hives. The whole had been sold with a guarantee regarding the wintering. The count in the spring of 1883 showed only two or three stocks less. The pay for the apiary sold was to be in the shape of Syrian and Palestine queens delivered in Europe. Before the number sent had been completed, cholera broke out in Egypt, and quarantine regulations were established in all European ports, and steamer communications became very irregular, so that many of the shipments arrived in poor order or dead, all having

been delayed three days or more on the way. When the journey is already one of eleven days, it makes considerable difference to add three or four more days, and with eighteen to twenty days by post through several degrees of latitude, very careful packing is necessary to insure any degree of success. One lot of sixteen queens arrived in Munich from Beyrout over forty days after mailing with only dead bees in the boxes. Then came the establishing of a cordon of guards about Beyrout, and Mr. Balden-perger, the young man who had purchased the apiary, after having suffered from the Syrian climate (although he was born in Palestine), was obliged to leave Beyrout suddenly by land, there being no steamers. The journey by sea to Palestine takes twelve hours, but by land six days, and with quarantine added, this journey stretched out to eighteen days!

From these remarks one can comprehend some of the difficulties met with in conducting the importation of bees from the Orient, and that—much as one would like to know just what he could promise and fulfil—he is often at a great loss to know what to do. With all this in view, after thinking over what was to be done in 1884, I concluded that, unless the attempt to import queens from the East in any considerable numbers, and of the races desired, be given up, the only way would be to try another journey to Cyprus and Syria with the expectation of bringing back a quantity of queens and full stocks, and of making such arrangements as would make the receipt of further shipments more certain. I therefore announced another journey to Cyprus and Syria, and made offers to purchase both the Mount Lebanon apiary and the Cyprus apiary. The latter I knew was reduced to a small number of stocks, but I supposed the former, located at Beyrout, must contain some sixty or seventy stocks at least, not having received from any one a single hint that it was in any other than a fairly prosperous condition. I supposed, therefore, that my principal work would be in Cyprus—to bring up the Cyprus apiary by purchasing bees of the natives and transferring them into new-made-comb hives, as well as to rear a lot of queens. Hence, I went there first and began this work—and, sure enough, I found plenty of work. My former assistant, a native of Syria, was engaged to aid me again. Imagine our surprise, upon coming over to Beyrout, to find that the Mount Lebanon apiary consisted of but four stocks of bees, all weak, and with but two laying queens, and a lot of empty hives with dry combs; the latter all more or less damaged by moth-larvæ and mice. However, there was no use crying over spilled milk; nor dead bees, so, accepting the stocks, hives, and combs at their value, I hired a Turk to make me a lot of boxes, and set about purchasing stocks and transferring them. The apiary now numbers forty stocks, and we are adding to it daily, while some queens and full stocks have already been sent out. I shall take a lot with me, but intend leaving some forty stocks in good order under the charge of my Syrian bee-keeper, who will make shipments to me from time to time.

Some idea of the fatigues of such an undertaking can be gained from the statement that my usual day's work, both in Cyprus and Syria, is from five in the morning until ten or eleven in the evening, with only barely time to take my meals, sometimes even only a piece of bread has been all the dinner I have found time to eat; and once, when getting ready a shipment of bees, I worked all night, or from five in the morning until five in the afternoon of the following day, taking out only time to eat. The weekly steamer was to leave twenty-four hours earlier than usual, and there was no other way to do, as extra help to work with bees on modern methods is not lying around loose in the East. Of course, with such fatiguing days' work and rough mountain journeys after bees, it is no wonder I have already had an attack of Syrian malarial fever; but medicine which I brought with me has fortunately checked it, and I hope to get

away before it can do much with me, and in the bracing air of the Bavarian highlands I will soon be all right again.

Whether these efforts, which I have surely made in the full belief that they would result in general good to apiculture, will ever be looked upon by the bee-keeping public in such a light or not, is a question which, while not troubling me greatly, has naturally enough often suggested itself to my mind. Had a recent writer in the *American Bee Journal* (see page 152, Feb. A. B. J.) possessed a few more facts about these matters, he would probably have omitted, or greatly modified, some allusions they made. He likely did not know that some ten years ago I began giving the bee-keeping public (through translations, &c., which brought no money into my pocket) information about Eastern bees, and that, after more than four years of direct hard labour in trying, tropical climates, I have probably injured my health permanently, and am actually poorer in pocket than when I set out from my native land. He surely did not imagine that during these four years I have often worked for weeks in succession twelve to fourteen hours daily, sometimes all night; and often the best bed I could find was a plank; and I have more than once been obliged to make a meal of dry bread alone, or of dry bread and olives, and that eaten by the light of the moon or of a camp-fire after a hard day's work. Exposed to the attacks of insects which abound in the tropics, of wild beasts sometimes, not entirely safe from Moslem fanaticism, and endeavouring to labour hard in a malarial climate, I have had my full share of trials in these directions. It is perhaps time I returned to my native land, if I have stayed away so long that any considerable number of my countrymen begin to doubt my being any longer an American, which, at least, seems to be the case with the *American Bee Journal* writer above referred to, who honours (?) me by applying to me the expression, 'a man who once lived in America!' For my part, I have never been a bit ashamed to own that I was born in Michigan, my parents and grandparents in the Eastern and New England States, and that I have heard that one of my great-grandfathers did come from Old England. Pray what could be this writer's definition of an American? It would be interesting to know whether we really have any American bee-keepers or not. I have dwelt upon this point for the sake of using it as an illustration, since it seems to me to be typical of many of the ideas on bee-keeping matters put forth by the said writer, that is, his ideas are sometimes put forth either without especial thought or before the ground covered by them has been canvassed in all directions. I do not mean to say that much that is valuable does not come from his pen, but only to say to beginners, who cannot always hit upon the shining nuggets hidden amongst corroding earthen, that a good manual of bee-culture would be a better guide for them than the articles of the writer referred to.

Nearly two years ago Mr. D. A. Jones, of Canada, after having gained a wide reputation through his connexion with this Eastern bee enterprise, discontinued the business, because, as he said, there was no money in it, and he might bring himself into the streets trying to introduce better bees, and nobody would thank him for it. Now I haven't such a bad opinion as that of my own countrymen, nor of the world in general; but I fully believe that the general verdict will render me simple justice. I do not ask my countrymen, nor bee-keepers of any other nationality, to favour me with orders for bees they do not want; but, fortunately, be it said to the credit of Germany, I am able to dispose of more Cyprian and Syrian queens in the land I call (for the time being) my home, than seem to be wanted in all America. But what I do ask is, that my statement be credited when I say that I never have intentionally pursued any course which I did not fully believe was in the interests of, and favourable to the advancement of, apiculture; and when I recommend Cyprian and Syrian

bees, it is because I believe their introduction will result in good to apicultural interests.—FRANK BENTON, *Beesport, Syria, April 12th.*

#### REMOVING QUEEN TO INCREASE HONEY HARVEST.—FERTILE WORKERS.

In reply to a query as to whether a Syrian or Cyprian queen could not be removed when the honey season arrives, and the bees be induced to devote their energies to the imbuing of honey, I must emphatically say 'No'; the queens of these races must *never* be removed for the above purpose; and as this is one of the doctrines taught by a certain professor, and pretty well preached in the *Journal*, I will state at length why queens should not be removed, and special reasons why Cyprians or Syrians should not.

I will take as conceded that bees live according to the work they do (which is about seven weeks in the honey season), and that the energies of one generation are directed to produce a succeeding one—their storing food for winter is to this end. Now if you remove their queen, they will at once start to rear another, and it will be twenty-eight days before she begins to lay; queens sometimes lay sooner than this, but if they do I have invariably found them worthless. Instinct teaches these insects that if they are to live to feed, care, and work for the future brood, they must 'conserve' their energies; therefore they turn idle as it were, and you will not get the honey expected. Nearly all the late authorities put down the rule, 'That if bees were numerous and failed to store honey, they were queenless,' and they were correct. A better plan would be, after removing the queen—which, by the way, is not an easy thing to do in a strong black stock as she wants finding—to unite bees and combs to another strong stock, thus the bees and brood of one stock would be set at liberty, and be stimulated by the presence of the laying-queen of another; and if they swarmed, which probably they would in a fortnight by properly treating them, they would be further stimulated and a good harvest got from them, of course at the cost of a strong stock.

If a queen of these new races is removed in rearing another, a lot of fertile workers are also reared, and these would begin laying as soon, or sooner, than the young queen; and as I have had four combs (14 ins. by 102 ins.) egged in every cell, and some cells upwards of six eggs in them within twenty-four hours, I think you will agree with me that these queens must not on any account be removed with a view to increase the harvest of honey. If you want a good harvest from these new bees, the foundation of success for one year must be laid in August of the preceding, in which month they must be kept hard at breeding, and the first week in September fed up to 20 lbs. at least of sealed stores (if worked on the syrup system), and on or before the 14th, packed up for winter, when they must have not less than 8 lbs. of bees in each colony, if 12 lbs. so much the better. The entrance of the hive must be left wide open, or at least 6 ins. by 1 in., dry, porous quilts on top, over which the wind can freely play to keep them dry, and let them strictly alone until April. On the first fine warm day they may be examined, and if running short of stores, 10 to 14 lbs. of stiff syrup should be fed to them, all at once on a very fine warm day, and all combs not well crowded with bees removed; they will rapidly increase, must be kept well crowded up, and frames of comb only inserted when they can cover both sides as soon as put in, which must be put next the dummy, and never between brood or frames of comb.

By the time cherries are in bloom we shall have 70,000 brood from the egg up, 100,000 young hatched out bees, and 70,000 'fielders'; this may be taken as their full strength, and ought to yield a large surplus every fine day.



The 'honey harvest,' although spoken of as only lasting a short time, should really embrace the following: pears, gooseberries, plums, and cherries, about all at one time, and as they go, the apples, then immediately after the incomparable sycamore, to last from three to six weeks, generally a month. After this there is a short lull, filled up with wild mustard, raspberries, &c.; then follows the first crop of white clover, and when out, the interval between the second is filled with what is on the road sides, waste places, &c.; then follow limes, when they bloom; and to close up the season, mustard or heather. Thus by moving your bees about a little the honey harvest may be made continuous from April to September, and your stocks in fine condition to pack up for winter.

On reference to the *Journal* for Dec. 15th, it will be seen that for certain reasons I do not recommend the pure race of these bees, where a very large crop of honey is wanted, but rather the hybrids: they possess the following desirable qualities over blacks: greater brooders, greater workers, longer lives, greater caution in bad weather, better bees for wintering, coming out in the spring with all the August bred bees, no inclination to rob other stocks, and, best of all, they pack their brood all in one mass, allowing you to take all the honey without extracting from brood combs.

The figures I have given look very large, but I am sure they are well within the margin: I get them thus: in the season, 14 square feet of brood-comb can be measured, and by calculating the number of cells to the foot, it will come to more than 76,000; then as these will hatch out in 21 days, and that they don't begin hatching until 28 days old, will give us over 100,000 young bees caring for the brood and keeping it warm; then supposing they only lived three weeks longer, this will give us 76,000 holders. I am convinced most of these bees live at least five weeks after beginning to hatch, if so, we shall have no less than 200,000 bees in the wing state in one hive at one time, without any 'doubling,' and will explain why E. F. Carroll got 1000 lbs. of extracted honey from one stock of Cyprians in 1882. A full colony of these bees are enough to frighten a timid operator, and instead of doubling them or removing the queen, though she is very easy to find amongst these bees, the first impulse would be to divide them into a dozen or more colonies. There is, of course, the danger of their swarming; but one writer has said these Syrian hybrids show no inclination to swarm, which I am pleased to be able to confirm. I have also noticed that when they do, they give a week's notice of the event before-hand.

When fertile workers appear, I find the best course to take is to wait until the brood is sealed, then with a sharp mauling knife, shave their heads off, the juices in their bodies go to feed the more desirable workers, the husks are turned out and worker-brood takes its place; there is thus very little loss or delay, as these fertile workers either soon die or they are only able to lay a small number of eggs each. JOHN HEWLETT, *Sheffield*.

#### PRIVILEGES OF COUNTY ASSOCIATIONS.

Will you kindly allow me a small space in your valuable paper to fully confirm the remarks of Mr. F. W. Riggall, made in a recent issue respecting our Lincolnshire Bee-keepers' Association? A few years ago I was appointed hon. sec. for this district; since then I have only once received notice of a Committee meeting. My last balance-sheet, sent in 1882, I have had no acknowledgment of, and I have been compelled to decline subscriptions simply because I could offer no benefit in return. As regards this part of the county the Association is of not the slightest use. Personally I have very little spare time at my disposal, but there is any amount

of good work to be done in this neighbourhood amongst the cottagers, who are nearly all working on the old straw-skip-and-brimstone principle.—W. B. JAVOXS, *Market Rasen*.

## Review.

A DICTIONARY OF PRACTICAL APICULTURE. *Being the correct Meaning of nearly five hundred Words, according to the Usage of the best Writers; intended as a Guide to Uniformity of Expression amongst Bee-keepers.* By JOHN PHIN. (New York: 1884.)—Mr. Phin at one time held the position of Professor of Agriculture in the Agricultural College of the State of Pennsylvania, and was also the lecturer on apiculture. We may therefore have the assurance that he is well calculated to undertake the very delicate task of compiling a technical dictionary like that now before us. He has evidently taken great pains in his work, and has consulted a large number of authors and treatises on apiculture. It will, however, require to pass through numerous editions before it attains the desired perfection, and some of its shortcomings are very evident. We failed, for example, to find the words 'Meal,' 'Methueglin,' 'Hydromel,' and very few of the words used by Dr. Butler are to be found, such as 'Sattle,' 'Dor,' 'Vindemiation,' 'Exsection,' &c.; words which, though archaic in themselves, should have found a legal habitation in a bee-keepers' dictionary. There is also to be noticed a want of care in the references, such as 'Close-and frames; see Frames, Close-and;' but we fail to find this latter. The alphabetical consecutiveness is not always rigidly observed. We make these remarks in no unkindly spirit, but with the desire to point out the direction in which in future editions improvement is required. Though such is the community of language between America and this country that the book will be valuable to bee-keepers generally, yet there are many words in it which are specially American; and also there are many words rare in this country which are not to be found in it. There are some words which we are sorry to find in a dictionary without a caveat as to their use, such, for example, as the hybrid word, 'Apology' and others.

Upon the whole, however, we desire to tender our thanks to Mr. Phin for the great pains he has evidently taken, and for the saving of time and trouble which a publication like this will effect. We hope that the work will have a large circulation and that bee-keepers will give it a place in their library. The work is well printed, and is illustrated with numerous engravings.

#### THE BRITISH BEE-KEEPERS' ASSOCIATION.

(From the *Bee-keepers' Record*, June 15.)

The British Bee-keepers' Association is asserting so loudly its claim to be the representative authority among British bee-keepers, that we feel it our duty to look somewhat critically into its organization and conduct.

The *Bee-keeper's Record* is specially competent to handle this question in an unbiassed manner, seeing that it is the only really independent Bee Journal in the United Kingdom.

When it is considered that we number amongst our personal friends, or as subscribers or contributors to these columns, the leading members and officials of the B. B. K. Association, it will be understood that any strictures we may pass will have an entirely impersonal character.

Let us, first of all, then call attention to an error of judgment which we think should be rectified at the earliest possible moment. We refer to the abandonment by the B. B. K. A. of their great Annual London Exhibition of bees, hives, and honey.

Our readers will recollect that the first bee show was held at the Crystal Palace in 1874, and its success was

so great as to induce the formation of the B.B.K.A. In each succeeding year this show has been the event to which both apiculturists and hive-makers have looked forward, and though of late it had become, through defective management, a very tame affair, it yet continued to be the mainstay of the B.B.K.A., and the one outward and visible sign of the progress of bee-keeping in the United Kingdom. There bee-keepers of all kinds could meet on common ground, and could compete without fear or favour, whilst hive-makers saw in the schedule of money and other prizes an incentive to the exhibition of their newest and most ingenious hives and appliances, which, though often nothing but monuments of mistaken ingenuity, yet furnished food for the criticism and occasionally the emulation of the bee-keepers present.

It is true that last year's exhibition was financially a failure, yet the causes thereof lay on the surface, and this one non-success furnishes no reason for the abandonment of future Annual Exhibitions. We will briefly point out how an Annual Bee-show could be made to 'pay.' . . . .

We feel confident that an exhibition such as we have described, would result, as it ought to, in a handsome surplus; in any case there would not be a repetition of the 1883 fiasco, nor, we trust, of the 1884 surrender.

## Echoes from the Hives.

*Devonshire.*—Having been prevented from sending the rain-fall for the last two months, I now forward it on the principle, 'Better late than never.' For April the total fall was 2.21 inches; most in twenty-four hours, 51 cents on the 4th; and there were eleven wet days. In April, 1883, the total fall was 2.31 inches, the number of wet days was twelve, including snow on two. In May the rainfall was 161 cents, there were nine wet days; the corresponding month last year there were 204 cents, with fifteen wet days. Bees are now in full swing, honey is coming in very fast, and already we hear of large quantities being gathered in all parts of the county. The weather is all that can be desired, and as I write (the 23rd June) everything promises to be a good honey year. There will be no difficulty in disposing of it, as already I have heard from several firms saying that they are ready to purchase any quantity of comb honey in sections from our members. A short time since, in going to inspect various apiaries, I was asked to look at a hive, as the bees would not work in the super; and I actually discovered that the bees must have been dead for nearly two months, and the section-tray was put on without examining the stock, because it was the beginning of June. The lady is much afraid of bees, she duly smoked the hive prior to putting on the super, and thoroughly protected herself with veil, gloves, and nobody knows what else besides. She thought they were a little weak, only having seen one bee for some time. Very glad to report that she will commence now in real earnest and not be such a coward in future.—Wm. N. G., *Hon. Sec. D. and E. B. K. A.*

*North Leicestershire.*—Three slight showers, giving a total amount of .05 in., is all the rain that has fallen during the three weeks ending 24th inst. Warm, cloudy days have been very prevalent, and the bees have not failed to avail themselves of it. Supers are filling rapidly already, and unless the results are marred by late swarming, a heavy yield may be expected. Beans are still in bloom; clover just coming on, but the limes are backward. The sycamore leaves glisten with honey dew, which, fortunately, is unheeded by the bees.—E. B.

*Dorset.*—The bees in Dorsetshire are doing better than they have since 1878, and I fully expect there will be the largest yield of honey ever known in the county.—W. H. DEXMAN.

*Cheshire, Sandbach.*—Bees doing well; very strong all through the spring; I have three stock hives. First super put on 9th May, taken off 9th June; weight 15 lbs.; now again nearly filled. Ten-frame bar-hive supered 20th May; has now sixty 1-lb. sections in three crates nearly filled. The other supered 14th May; has 15-lb. glass almost filled, and also twenty-one 1-lb. sections. The first and last stocks are in straw hives. I have not taken any swarm this year, as artificial swarming is rendered difficult by very close proximity of hives to one another.—T. MARRIOTT.

*Leamington, Weston, Honey Cott.*—The bees now are going with a boom; supers are filling well, while hives that have been doubled for extracting are giving plenty of work for any spare time I have to attend them.—JOHN WALTON, *June 25th.*

*Wells, Weyford, June 21st.*—The honey-bees are at work in earnest now. This two weeks back I had six swarms, two of which I united into one—I mean two first swarms into one. The hive was half full of bees, and the size of the hive was 18 in. wide by 15 in. high. I had the bees scented, but I failed to get one of the queens, and consequently they had a great fight, and I got one of the queens wounded next morning lying under the flight-board. I have her caged up, and she is getting pretty lively. I have not examined my supers yet. I mean on the straw skeps. The sections on the bar-frame hive are nearly all sealed up. About a week ago I had a very large swarm from the bar-frame hive; the swarm filled my garden. The bee men in my locality lost their all; all their bees died in spring. I feed all my swarms for a fortnight after swarming while comb-building. The past two or three weeks has been a good season for the pots. I think I shall get up my stocks to twenty.—J. S.

*Essex, June 23rd.*—A very dry month. Since May 23rd rain has fallen here but twice (June 5th and 22nd). With a few exceptions both honey and swarms are very scarce. The white clover is now in bloom, and bees for the past week have been working well. Honey-dews are constant, but whether this is any advantage or not I cannot say; it appears very thick upon sycamore and lilac, but I have not seen a bee near either of these trees since their blossom has fallen. The thermometer until the last few days has seldom been above 55 in the shade, almost as cold as our last winter.—G. H. A.

*Bedford, Coppe, June 23rd.*—Bees here have done very well at present; we have had a week's dull weather, but no rain to speak of this month. Up to June 9th I have taken from one hive 17½ lbs. extracted; am running my hives on doubling system, but with top frames just half the length of brood frames, six inches deep. I use as extra for a common galvanised pail, fitted to take two small frames at once. I find it answer well. The clover is just out now; limes will be out in a few days. I have had but one swarm, and that from a skep this season. Honey seems to be very thick this season; it sets quite hard in about three days.—A. F.

*Abingdon, June 24th.*—The weather is capital for the bees here; my bees are working most wonderfully well; they are at work at six in the morning, and remain at work till eight o'clock at night, and by using Brickland's improved glass super I have taken 3½ lbs. of splendid clear white sealed honey from one straw skep from May 26th till June 21st, and have more supers nearly fit to come off. They are all on straw skeps, and kept in a small garden very near the centre of the town, and have to fly over the houses to go to work.—D. BRICKLAND.

*South Cornwall, June 25th.*—We have had a fortnight of rare weather for the bees, and they have gathered abundance of clover honey. I expected great things from a swarm which I had placed in a skep containing five or six nice pieces of last year's comb, white, clean, and regular; but this morning I observed a flood of honey running over the floor-board, and examination showed

nearly all the combs down in a heap, and a fine queen and scores of workers smothered. The amount of comb had been at least doubled in eight days, and, being very tender, more honey had apparently been brought in than it could sustain. A similar circumstance is echoed from a neighbour's apiary. What a pity it is that swarming cannot be prevented! But can we wonder that English bees follow the colonising example of their country? It is not only that they are not supered in time. Here is a very strong and large skep, with an Abbott's Cottage Super on it, half full of beautiful comb and clover honey. While I was overhauling the downward these discontented creatures were actually swarming behind my back! Well, they shall go in with the queenless bit.—C. R. S.

*Laudible.*—We are enjoying splendid bee weather here now. Stocks generally are not as strong, however, as they ought to be; the winter and spring were so trying.—A. OSWALD LEWIS.

## Queries and Replies.

QUERY No. 780. (SOMERSET.) *Opening Hives, &c.*

What time of day would you recommend a beginner to choose for opening hives, putting on supers, &c.? Also could you not give us a line in the *Journal* once a month quoting the market price of comb and run honey? It would be a convenience, I think, to county bee-keepers, and they would have some authority to show for their charges. I made an artificial swarm from my single skep according to your directions on the 17th May, and put them into a bar-frame; they have now filled seven frames, and are working at sections in a super. The "Hunts" you give are very useful, and I intend to lend you *Journal* to the cottagers round about who keep bees. I. The middle of a fine day, when many bees are about at work at the present time, but as the honey harvest begins to fail, the evening is best for fear of robbing. We could hardly give the market price of honey, as it varies so greatly according to locality, and also whether the market price is as between producer and dealer, or between dealer and consumer, or between producer and consumer. We are glad to find our "Hunts" useful to you. Your example in lending the *Journal* to your poor neighbours is worthy of extend. Following.

QUERY No. 781. (E. L. H.) *Feeding after Honey Harvest.*

I. Supposing my stock of bees consists of twelve frames, each of them having at least one-fourth of the frame sealed honey. Is it necessary to feed directly the honey harvest is over—say middle of July, and continue doing so until October? Or should this honey be extracted in July and then feed up? A. A stock containing twelve frames covered with bees and partially filled with honey now should be supered, and will no doubt give a good result by the end of the harvest, which you may reckon (weather permitting) to extend to the end of July or into August. The outside frames may be extracted from, but it is not advisable to do so from those containing brood. It is not necessary to feed unless you leave too small a quantity of store to last over the winter, but it is generally done in small stimulative quantities to keep the queen brooding late, and so ensure a supply of young bees for wintering. 2. *Artificial swarm after Honey Harvest.* Can I make artificial swarm with same-hive directly the harvest is over, putting six combs to swarm and leaving six to stock; and then should stock and swarm be left alone, or should foundation be given them and begin building them up again all through August?—A. To make an artificial swarm after the honey harvest is over is contrary not only to nature, but to the art of bee-keeping; as the queen raised in the stock could not be fertilised except by the nearest chance of a few drones existing somewhere near you. If, however, you find a stock very strong and choose to buy a queen or have a spare one, you may divide, and by feed-

ing up obtain good results, but do not give any more room in either stock or off-st.

QUERY No. 782. (T. JARVIS.) *Wasps' Nest.*—A few days since I observed a wasps' nest formed upon a goose-berry-bush in my garden; in fact, one goose-berry is nearly embedded in the nest. I have cut the branch off, and placed the end in water in order to preserve the fresh appearance of foliage as long as possible. The queen remained in it until this morning. The nest is about 2½ or 3 inches in diameter, and contains a number of eggs. Is it possible to preserve this curiosity? and if so, by what means? A.—The case you report is certainly singular; indeed, we never heard of one similar. We are not aware of any means that could be taken to preserve the specimen. We should have raised a small stage to support the nest, and allowed it to be worked out to perfection. A taxidermist, perhaps, might preserve the specimen under a glass case.

QUERY No. 783. (A. TYRONE MAN, *Cockstown.*) *Two Queens in a Hive.*—On May 19th I removed the queen from a small black stock which only covered five frames, and introduced one of Messrs. Abbott Bros' Ligurian queens. I saw young Ligurian bees out for a fly on the 19th of this month. I have since then often examined this hive, which increased rapidly to cover eight frames, and saw nothing unusual. Yesterday, June 17th, a friend of mine had a cast swarm off Ligurians, which he had swarmed artificially. We went over his stock, cut out four fine queen-cells, and returned the cast to its hive again. I gave me two of the queen-cells to raise a queen with. I did so by taking the second frame from the back, and putting it in an empty hive. I got the queen on the next or third frame, put it back, passed by the fourth, and took out the fifth, and was putting it in when I discovered a fine black queen-cell. I caught her, and in a large jar at the head of the black swarm, which I raised artificially. Can you account for the two queens, one black and one Ligurian, being in the same hive? A. It is possible that a developing young hive of its queen, before inserting the Ligurian queen-cell, may have been raised from which the black queen issued, and was allowed to remain in the honey-cases of two queens in a hive are by no means uncommon. It might also chance that a small swarm of blacks united themselves to your Ligurian colony.

QUERY No. 784. (A. BURGESS.) *Best Covering for Hives.*—After placing a swarm in a bar-frame hive, I covered it at with a quilt of calico, and above that two of cap-ty. But I find that in a short time the bees have tumbled away the calico between the bars until it is filled with holes. What is generally used as a first covering? I did not like putting a quilt of many coloured paper next the frames, thinking the dye might be injurious. A. The best covering next to the frames we have found to be what is usually termed "duck," a kind of stout best-ticking sold by most drapers and upholsterers. In America the covering most used during summer is enamelled cloth, the smooth side downwards. We have found this beneficial to the bees, and more durable, and the propolis action is less than with any other material we have tried. 2. *Spreading Brood.*

Is it advisable to spread the brood in the case of swarms during summer in the same as advised for stocks in the spring? A.—No, it is quite unnecessary. The breeding powers of good queens during the summer months are so great, that the loss interference with the brood-nest the better for the colony; indeed, at this time the hives are so full of brood that you would find it a difficult matter to spread it. 3. *Feeding.* A large hive having sent out a swarm and a cast, is consequently so much depopulated, that but few labourers are to be seen passing to and fro to the fields. Such being the case, I have been thinking that if I were to feed it until a month after casting, it would, by sparing them the

labour of gathering their own living, enable all the bees to remain at home and assist in the duties of attending the brood, which would possibly thus be raised in larger quantities, and the hive more quickly repopulated. Kindly say if I should be right in carrying out this idea? *A.*—Generally speaking, considerable store of honey has been laid up before swarming takes place; but if your hive is short of food, feed at once. There is always a very quiet period after a hive has been depleted by swarming; the bees, being all young, do not go to the fields to gather until about three weeks old. Even if stores are short you will find the population so small that little food will be taken.

#### NOTICES TO CORRESPONDENTS & INQUIRERS.

4114. —1. *Natural swarms building queen-cells.*—Possibly the swarm was a second one or cast containing a virgin queen which got lost on her wedding flight. If a first swarm, you may have injured the queen in your examination. If there were, as you say, 'no eggs,' it is obvious that the queen-cells cannot produce queens, and you had better requeen without delay. When there is a cessation of honey income bees cannot be better employed than in working out foundation by means of gentle feeding. 2. *Honey harvest.*—Your bees will no doubt recommence work in the supers when the clover opens and honey comes in. N.W. winds are not so good as S. or S.W. for the secretion of honey. 3. *Combination Hive.*—A Combination hive has the frames parallel with the front and has a space at back for sections.

T. MARMON. —1. Yes. —2. Wait until the top ones are filled or nearly so; remove the middle sections which are finished first; close up the partially filled ones and place empty ones outside. 3. If swarms issue capture and return them.

J. IRWIN-PACKINGTON. —1. *Supers.*—Perhaps the bees in bar-frame hive would accept a frame of sections at the back of the brood-nest. If when partially worked out these are removed with the bees till in them and put in the middle of a super crate the old crate will be accepted and filled. In the case of the skep, by putting a piece of brood comb in one of the sections and drumming the bees up into it. 2. Use thin foundation. 3. *Removing Bees from Sections.*—Puff smoke into it, turn it up and carry it about drumming it until the bees have all flown home, or put it into a box with a glass window and when a lot of bees are on the glass let them out and replace before any others can get in; repeat this until all are out. 4. *General Work.*—Get all the honey you can from your skeps, drive in September and transfer the best of the combs.

A BEDFORDSHIRE BEE-KEEPER. —1. *Zinc-excluder in front of Hive.*—Yes, to prevent first swarms. 2. No, not to prevent casts, as the queen, being a young one, must have means of leaving for fertilisation. 3. *Excluder and Drones.*—The frames containing drone-comb should be outside the divider. If drones are in existence they must make the best of their confinement, or you may put on a drone-trap and capture the whole of them before inserting the excluder (or includer).

J. I. S. —*Living Bees.*—During the two hours the bees remained upon the stump, under the hive scouts were sent out, the hollow tree discovered, and the swarm guided to it direct. The bees should have been brushed from the stump with a goose-quill, moistened with a weak solution of carbolic acid, and the skep placed over them, when all would have entered. The swarm should then have been removed to a shady place, and the skep wedged up all round, to give air, and in the evening the bees might have been transferred to the frame or any other hive. Swarms, when deserting, always fly straight to the spot decided

upon, generally high enough to clear all obstacles in their route. When swarms are large and the weather is hot, very large skeps should be used, and they should be thoroughly shaded from the direct rays of the sun, plenty of air being given from below, and jets of water from a syringe thrown over them.

M. OLMOND. —*Weak Foundation—Given Wired Foundation.*—We fear that foundation made from adulterated wax is frequently put upon the market. We have used for some years in our own apiary the 'Given wired foundation,' which never falls nor breaks, and is made from pure wax. It is an American production, and is imported by Messrs. Neighbour, and, we believe, by others who deal in apiarian appliances. It has been objected to this foundation that the bees will not rear brood in those cells through which the wires pass; but in our own experience this has never been the case, the bees utilising the cells for brood, honey, and pollen, exactly the same as if no wire were used. The wire is so fine—not so thick as horse-hair—that the bees do not seem to notice it at all. We have over thirty colonies built upon this foundation, and have never known a sheet to fall. With large swarms and hot weather all other foundations we have tried will occasionally fall. The wired foundation should be inserted—with the wires hanging vertically—in the saw-cut in the top-bar of the frame. The wedge being withdrawn, the foundation will be held tightly in its place without any other fastening. We do not see that anything can be done in your case but to give fresh sheets of the wired foundation. The loss of time and honey is, however, a lamentable fact, and one from which we have suffered much in our own experience in days gone by.

W. J. MACDONALD. —1. *Removing Brood-comb.*—The removal of the brood-comb to the further side of the hive was unfortunate, and caused greater part of the mischief. 2. *Brood and Pollen Cells.*—It is a most easy matter to distinguish brood from honey or pollen cells. Probably the queen of your hive is old and worn out. 3. *Melting Combs with Canded Honey.*—We advise in the autumn to unite the bees to your other colony, and to melt down those parts of the comb containing the granulated or candied honey. No extractor will throw it out in its present state. The extractor should have been used before the winter. Place the comb, with a little water, over the fire, and bring it up to boiling. Set it aside to cool, and the wax will then be found in a sheet at the top; the honey in a liquid state at the bottom. The latter may be given to the bees as food.

IGNORAMUS. —1. *Transferring.*—To transfer your bees to the frame-hive is impossible. The newly-milted combs are too fragile to be handled this season. The old stock might have been transferred three weeks after the first swarm issued, but it is better now to allow all the three to remain until next spring. 2. *Drones.*—A large number of drones—a provision of nature—is usual in all swarming hives. They will be destroyed when there is no further use for them.

J. F. F., *Alton.* —*Flies.*—Any trap you might contrive to catch flies would most probably capture and kill as many bees. Flies are not considered among the enemies of bees; but bees do not desire any undue familiarity from them, and therefore they are ever driving them from the entrances of their hives. To prevent the frequency of the visits of flies to the interior of the bees' homes, stocks must be kept strong; and if there happens to be with you a too great preponderance in the number of these insects, the most natural mode of reducing it would be the encouragement in your locality of that lovely little bird, the common English fly-catcher. This bird has been accused of having a love for bees, but we believe it has been proved that

the accusation is unjust. We are pleased to hear of the progress of bee-keeping in your parish. Might we recommend you to place yourself in communication with the Secretary of the Hampshire B. K. A., E. H. Bellairs, Esq., Wingfield, Christ Church?

**A LOVER OF BEES, *Gadstone*.**—Having a swarm from a bar-frame hive in a skep would not be the cause of their desertion. It is difficult to say what may be the reason of the vagaries of bees; perhaps they had exhausted the store brought away with them, and not being furnished with a fresh supply they endeavoured to procure it for themselves.

**A LOVER OF BEES, *Channah*.** There are several bee-periodicals published in America. Both California and New Zealand furnish attractions for bee-keepers; and a bee-farm in either of them, well worked and managed, would be a source of profit. So much might be said in favour of either, that the preference to be given should be decided by personal production.

**AMATEUR.**—Bees are architects of no slight degree. The frames in your hive were weak at certain places, and the bees to rectify this built buttresses to strengthen them. When your frames are older and rigid no harm will result from your sawing them.

**W. G. P. C. 1, *Honey Harvest*.** If your neighbourhood is favourable for honey getting, the season is prolonged, and your stock is vigorous, there is a prospect of your reaping a honey harvest this season. By the time this meets your eye, it will be desirable to put on a crate of sections. 2. *Sections.* The sections sold by hive-dealers are generally furnished with a small bit of foundation; if you insert it yourself, it would be of advantage to insert a larger piece.

*Several communications and queries have reached us too late for insertion. They will be attended to in our next.*

**DO** not order your Hives and Appliances until you have seen E. C. WALTON'S CATALOGUE for 1884, consisting of 36 pages, fully illustrated.

*Sent free for A. Stamp on receipt of Address.*

**E. C. WALTON,**  
NORTH MUSKHAM, NEWARK.

The only Weekly Bee Paper in the World.

**THE AMERICAN BEE JOURNAL**

*Established in 1861.*

Edited and published by THOMAS G. NEWMAN, at 925 West Madison Street, Chicago, Illinois, U.S.A., and will be sent to European Subscribers at 10s. 6d. per annum for the Weekly, or 5s. for the Monthly, including Postage. The money may be sent by International Postal Money Orders on Chicago. London Agents, Messrs. GEO. NEWBORN & SONS, 119 Regent Street, W.

*Bronze Medal awarded for Straw Skeps at the Great Crystal Palace Show, 1875.*

Seventy-ninth Edition. Price One Shilling.

**SEVENTY POUNDS A-YEAR:**

HOW I MAKE IT BY MY BEES.

By the late J. W. PADDEN.

Also, by the same Author, price Sixpence.

**EARLY ARTIFICIAL BEE-SWARMING.**

No watching required.

Apply to Mrs. J. W. PADDEN, The Chestnuts, Alfriston, Sussex, by whom the same manufacturers of 'Economic Bee Furniture' are employed as formerly. (40)

**LEICESTERSHIRE  
BEE-KEEPERS' ASSOCIATION.**

**PRIZE SCHEDULES** of the LEICESTER and MELTON MOWBRAY SHOWS can be had on application to the Secretary, Mr. EDWIN BALL, WALTHAM, MELTON MOWBRAY. (72)

**CAMBRIDGESHIRE AND ISLE OF ELY  
AGRICULTURAL SOCIETY**

**BEE-KEEPERS' ASSOCIATION.**

**EXHIBITION AT CAMBRIDGE,**  
21<sup>ST</sup> AND 25<sup>TH</sup> JULY, 1884.

**18 Prizes Offered for Hives and Honey.**

The Prizes for Hives are open to all England, and those for Honey to Members of either of the above Societies, and no Entrance Fee charged for Honey.

*Entries close Monday, July 7th.*

Prize Lists and Forms to be had of  
Mr. R. PETERS, 7 Downing Street, Cambridge.

**UFFINGTON COTTAGE GARDEN  
BEE & HONEY SHOW,**

And Sale of Useful and Ornamental Work,

Will be held in the beautiful GROUNDS OF UFFINGTON HOUSE, by the kind permission of THE EARL OF LISBURY,

On THURSDAY, JULY 10th, 1884

*Prize List and Entry Forms for Honey and Wax, to be obtained of Messrs. SELLS, Uffington, Stamford.*

ENTRIES CLOSE JULY 5.

**E. M. HART & CO.,**

The LONGSTOCK HIVE Manufactory,  
STOCKBRIDGE, HANTS.

**SPECIALITIES:**

HIVES, complete, from 6s. SECTIONS, V cut, in 6 sizes. FOUNDATION, Flat, or natural basal.

CLARK'S COLD BLAST SMOKER. 'Far and away the best Smoker.' 3s., post free.

HART'S SIMPLEX FEEDERS. 'The easiest and best to manage.' 1s. 6d. each, 15s. per dozen.

THE 'SWANMORE' SECTION CRATE. 'The most perfect Crate made.' (60)

The Trade supplied. Price List on application.

**JOHN T. KINNEAR,**

IMPORTER OF

**AMERICAN APIARIAN APPLIANCES,**  
8 REFORM STREET, DUNDEE.

*Price List on application.* (65)

**BEE-KEEPERS' GUIDE, OR, MANUAL OF THE ART.** 11,000 sold since 1876. 12th Thousand just out. 10th Thousand sold in just four months. 2000 sold the last year. More than fifty pages, and more than fifty costly Illustrations, were added in 8th Edition. The whole work has been thoroughly revised, and contains the very latest in respect to Bee-keeping.

Price by mail, \$1 25. Liberal discounts made to Dealers and to Clubs. Address A. J. COOK, Author and Publisher, Lansing, Michigan.

State Agricultural College. April 14, 1883.

**DR. PINE'S**

**Registered Removable Metal Frame Ends.**

*Prize Medal, B.B.K.A., 1882; and numerous other Prizes.*

BY the use of this valuable invention the making of Frames is simplified. No metal runners are required, all systems of frames are rendered interchangeable, and propagation is reduced to a minimum.

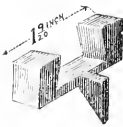

Unfortunately, as is the case with all inventions of merit, numerous substitutes are being introduced under the name of 'improvements.' But there is not one of these so-called 'improvements' which does not possess defects from which the original invention is free.

It is, therefore, absolutely necessary when ordering Hives to specify that the Frames are to be fitted with 'DR. PINE'S ENDS,' and with no others. All Hive-makers will supply Hives fitted with them, and generally without extra charge, the small cost being saved in diminished cost of labour.

Price of the Ends, 1s. per doz. or 10s. per gross.

**DR. PINE'S**

**Woven Wire Veils.**

*Prize Medal, B.B.K.A., 1879.*

Do not confine the breath, do not obstruct the sight, and cannot be blown against the face or ears.

Price 2s. 6d. each.



**DR. PINE'S BEE-KEEPERS' LOTION**

Is the acknowledged Remedy for Stings, especially for removing the subsequent inflammation. Price 1s. 6d. per bottle.

*The above Inventions may be obtained from*

Messrs. NEIGHBOUR & SONS, Regent St. & Holborn, London; And from all respectable Dealers in Bee-keepers' Requisites.

*Dealers may obtain Wholesale Prices from the Inventor,*

Mr. F. LYON, 92 Harleyford Road, London, S.E.

**BEE VEILS.** Improved with Wire Gauze Fronts, or with Silk Brussels Net. Post free 18 Stamps. Address B. DIXON, Papworth-Everard, St. Ives, Hunts. (59)

**CANE (PREPARED)** for making Straw Skeps. 1 lb. postal packages—Fine, 2s. 3d.; Coarse, 1s. 3d.—free. SALICYLIC ACID, 1s. per oz. post free. THYMOL, 1s. packets free. Either of the foregoing cheaper in quantity. Address J. R. W. HOLE, Tarrington, Ledbury.

**THOMAS B. BLOW,**

WELWYN, HERTS,

Manufacturer of Bee-keeping Appliances of every Description,

And IMPORTER OF FOREIGN BEES,

REGS to call attention to the unrivalled quality of his productions. By the aid of special power machinery he is enabled to combine moderate prices with high quality. Mere lowness of price is not so much aimed at as accurate fit and finish, all goods being adapted both for the convenience of the Bees and ease of manipulation to the Bee-keeper.

ILLUSTRATED CATALOGUE, 48 Pages, 50 Illustrations, full of interesting and useful information, Free on application.

**THE HEREFORDSHIRE**

**SCHOOL OF APICULTURE**

SUPPLY BEES, HIVES, and everything pertaining to Modern Bee-culture. Hives made only of the best well-seasoned wood, a quantity of which is always kept ready cut and prepared for putting together.

Awarded Honourable Mention for a Hive exhibited at COCK INDUSTRIAL EXHIBITIONS, 1883, and First Prizes at various County Shows. Revised Catalogue for 1884.

**J. R. W. HOLE,**

*(Export to the Herfordshire B. K. A., qualified by B. B. K. A. Certificate.)*

Address TARRINGTON, LEDBURY.

**CHARLES T. OVERTON,**

*Bees-Inspector to the Sussex Bee-keepers' Association,*

**THREE BRIDGES, SUSSEX,**

Bees to call attention of all Beekeepers to his NEW STOCK OF BEE-KEEPING APPLIANCES for 1884, and hopes to be favoured with their support.

*Sales, and Royal Medal, and other Prizes, awarded at Expositions, Knightsbridge, Ho. Reg., and other Shows, for the Best Bees, Hives, Bees, Scaffolds, Sumps, Extractors, Cane Foundation, &c.*

Orders can now be looked for Prime Stocks, and Swarms of ENGLISH, LIGURIAN and other Foreign BEES, for early spring delivery; also Imported LIGURIAN QUEENS. First consignment will arrive early in May.

**SPECIALITIES.**

The COWAN HIVE, and Extractors; Bincham Smokers, the best in use; Sumpers; Homer Racks; Comb Foundation, American 2-lb. and 1-lb. Sections; FLAT TOP STRAW HIVES, with hole in top for feeding and opening, 2-cells; Crates of 18 1-lb. Sections for Straw Hives, 5s. each, complete.

Questions on Bees and their Management answered by return of post, 3d. stamps. Send 7d. for Modern Bee-keeping, 1s. 8d. for Beehive Bee-keepers' Guide. Catalogue free on application.

SUPERIOR BEE VEILS, Wire Gauze Fronts, 1s. each, three for 2s. 9d., post free. Address WM. CURRIE, Halstead. 2025

**LINCOLNSHIRE AGRICULTURAL SOCIETY.**

**GRANTHAM EXHIBITION.**

PRIZES are offered for POULTRY and PIGEONS to the amount of £73; and for BEES, HONEY, HIVES, &c., amounting to £26. Entries for these Departments close on the 7th July.

For Schedules and Forms apply to—

St. Bonald's Square, Lincoln,  
21st June, 1884.

STEPHEN UPTON,  
Secretary.

# THE BRITISH BEE JOURNAL

Communications to the Editor to be addressed 'STRANGEWAYS' PRINTING OFFICE, Tower Street, St. Martin's Lane, W.C.'

[No. 150. VOL. XII.]

JULY 15, 1884.

[PUBLISHED FORTNIGHTLY.]

## Editorial, Notices, &c.

### THE CONFERENCE AT S. KENSINGTON.

#### IMPORTANT NOTICE.

##### ALTERATION OF THE TIME OF COMMENCEMENT.

In consequence of H. R. H. the Prince of Wales having selected July 24, 25, and 26, as the dates for the Conference over which His Royal Highness is to preside, the Conference arranged by the B. B. K. A. will commence at 11 a.m. each day, instead of 2 p.m., as previously announced. The subjects for discussion are: Friday, July 25, 'Foul Brood: its Nature as a Germ Disease; the Means of its Propagation, and the Method of its Cure,' to be introduced by Frank R. Cheshire, Esq., F.R.M.S. On Saturday, July 26, 'The Adulteration of Honey: the best Means of Detecting and Preventing it,' by Otto Hehner, Esq., F.C.S., F.I.C. Members of the Association desirous of being present at the Conferences are requested to make application to the Secretary for tickets of admission not later than Wednesday, July 16th. Admission to the Conference cannot be obtained except by ticket.

##### NOTICE TO COUNTY SECRETARIES.

The next Quarterly Meeting of County Representatives will be held in the Council Room of the Royal Horticultural Society, South Kensington, on Saturday, July 26th, at 3 p.m.

### THE EDUCATIONAL ACT AND APICULTURE.

The Examination Sub-Committee of the British Bee-keepers' Association, desirous of taking advantage of the encouraging response received from the President of the Committee and Council on Education to the letter of the Rev. Arundell Leakey, vicar of Aeton, Suffolk, have drawn up an outline of a scheme of graduated lessons for the teaching of intelligent and practical bee-keeping as a branch of Elementary science; and this they are anxious, as early as possible, to place before Mr. Mundella for his consideration.

This outline, they propose, should be taught by illustrated reading-books, 'descriptive and explanatory,' and by 'oral lessons and visible illustrations' with bees, hives, combs, and flowers,

showing how the subject might be made progressively educational, cultivating 'powers of exact observation,' and at the same time be made highly interesting not only as an intellectual amusement, but as opening out a field of useful and profitable industry for elder children in their homes, and thus be a means of bettering the condition of cottagers and the agricultural labouring classes.

The outline consists of a graduated scheme commencing with very easy and simple lessons suitable for quite young children, and advancing gradually till the whole theory and practice of bee-keeping are brought before the youthful mind. We know of nothing which will prove of such service to apiculture, and again we desire to thank Mr. Leakey for the position he has taken in this matter.

### ROYAL AGRICULTURAL SOCIETY, SHREWSBURY, AND BEE KEEPERS' ASSOCIATIONS.

We desire to remind bee-keepers in the neighbourhood of Shrewsbury of this show, and the opportunity it will furnish of forming Bee-keepers' Associations in the counties of North Wales. Since our map of the Counties of England and Wales, giving the Associations affiliated with the British, was published, Cardiganshire has succeeded in forming an Association; and it is hoped that such an impulse will be given to bee-keeping by the meeting at Shrewsbury that the remaining counties will follow the example set them by Cardiganshire.

### MR. CHESHIRE'S EXPERIMENTS ON FOUL BROOD.

We understand that the experiments made by Mr. Cheshire have conducted him to some important discoveries and results. In a communication received from that gentleman he says: 'I am not in need of any further specimens, but shall be willing to diagnose cases of suspicion upon receipt of specimen and stamped-directed envelope. Return thanks for me for many boxes of strong odour sent to me. The experimental stock is so improved as not to be recognised by its owner, except for its frames and surroundings. It surprises and delights me. Many sad, over-diseased stocks will, I hope, soon see their troubles over.'

### MR. FRANK BENTON AND EASTERN QUEENS.

In our last issue we gave insertion to a letter from Mr. Frank Benton, from which may be gathered some faint idea of the difficulties he has encountered, and the obstacles he has overcome, in his earnest desire to obtain for bee-keepers in this and other countries Cyprian, Syrian, and Holy Land bees under the belief that their introduction would prove a benefit to the interests of apiculture. We have heard of missionaries in the pursuit of their lofty vocation facing the deadliest perils; of botanists risking their lives in their desire to obtain some precious flower or rare plant; of discoverers who have endured all manner of privations to attain their object; and we are proud that we can point to a fellow-bee-keeper who has shown such an heroic endurance—such perseverance under difficulties, such an arduous bearing him onward amidst the surrounding causes of despondency in the hope of procuring these Eastern bees. In his letter there is a sentence which has a true Pauline ring in it: 'Exposed to the insects which abound in the tropics, of wild beasts sometimes, not entirely safe from Moslem fanaticism, and endeavouring to labour hard in a malarial climate, I have had my full share of trials in these directions.'

We cannot estimate too highly the indomitable spirit that has supported Mr. Benton for so many years; and we trust that such sacrifices as he has made, and such determination to achieve his purpose, will be ultimately crowned with success. We scarcely in this country have fully realised the value of these Eastern bees, or rather the results that might be derived from breeding from them. Earnest bee-keepers in this country are, however, carefully experimenting upon them, and we shall receive their reports in due time.

### THE VIRTUES OF HONEY.

We have been favoured, through the kindness of Mr. A. Neighbour, of Regent Street, with the loan of an old book, printed in 1759, entitled, *The Virtues of Honey in Preventing away of the Worst Disorders, and in the Cure of several others.* As honey appears to be resuming the place it once held in the estimation of the public as food and medicine, we may be usefully employing a portion of our columns in giving a few extracts from this little work. In the Introduction it says:—

'We seek from the remotest part of the world medicines of harsh and violent operation for our relief in several disorders, under which we should never suffer if we would use what the bee collects for us at our doors; and in as many others, which though no cure could make us escape, the same innocent and pleasant juice would cure. . . . There was a time when honey was more used, because the demand rose from necessity. Before the knowledge of sugar, this healthful sweet supplied its place; and there are to this time countries where it has the same prerogative.'

After speaking of the nature and origin, and different kinds of honey, it treats—

'Of the Virtues of Honey against a tough Phlegm.—Many persons, especially as they advance into years, are

troubled with a tough phlegm in their throat in a morning, which makes their breathing difficult, occasions them to speak hoarse and with difficulty, and brings on a continual hawking and coughing, till they have got it up. This is one of those complaints which does not amount to the name of a disease, and for which few consult a physician; yet it is a very troublesome and disagreeable one, painful to the person himself, and giving disgust to others. The complaint should not be slighted, for it will increase; sometimes it terminates in an asthma, and some have been carried off with an immediate death by the consequences of it, for by the straining to bring it up, they have broke a vessel, and bled to death upon the instant. If it were asked what medicine would be a cure for this infirmity, and a safe preventer of its return, the question would be difficultly answered; but in the place of such a medicine, if the person will take honey, he may be sure both of a present relief and a lasting cure. The best kind of honey for this disorder is that of our own produce, but it is necessary to have it in perfection. The fine English spring honey is the proper kind; and there is no need of the troublesome ceremony of taking it mixed up as a medicine. It may be eaten in its own form, and will no way do the business so well. Let the person who is troubled with this complaint set a pot of honey by his bedside, and the last thing at night take a large spoonful of it into his mouth, letting it go gently down. As soon as he wakes in the morning let him take another spoonful in the same manner. He will find ease the very first day, and more and more every day afterwards till he is perfectly recovered. After that he need not confine himself in a strict way to the taking it at any regular time, or in any certain quantity; but it will be advisable now and then to eat a little of it, to prevent a tendency in the same humour to bring on a relapse; and if at any time after taking cold, or from other accidents, he perceives the complaint coming on again, he should constantly take the same quantity night and morning for some time. It is very essential in this case to have pure and fine honey; and if our own spring honey cannot be got, the Swiss honey, which is sold under the general name of Narbonne, should be used in its place. Common honey such as is sold at grocers may increase the complaint which it is directed to relieve. There is no argument like fact, and one instance may prove this better than a volume of reasonings. The last spring a merchant in the city, who was troubled by this complaint, took honey by my advice in the manner just directed. He had been cautioned to get what was good, but without any particular directions on that head, as I had not then seen the extreme difference between one kind of honey and another. He found his complaint increase, but he had the resolution to continue the medicine, until one morning he was near choked. He constantly said, that since his taking the honey, he had always the taste of raw flour in his throat in a morning; and he was not mistaken; for on examining the honey he had taken all this time, we found flour mixed among it. This was done so clumsily, that on spreading a little of the honey thin upon a piece of blue paper, and looking at it with a reading glass, we could see the flour in small white lumps. There is no room for wonder at the effect this took upon the patient, for the flour thickened the phlegm into a paste. On taking some tolerably good English honey afterwards he recovered. It is difficult sometimes to discover the frauds that have been used in making up of honey, but in general what is thin and transparent, from whatever place it comes is the most likely to be pure; because all the common mixtures give it thickness and cloudiness.

'Of the Virtues of Honey against a Hoarseness.—A hoarseness is another of these troublesome complaints which does not amount to the name or nature of a



disease, but yet is capable of making the person very uneasy, and is commonly a very lasting disorder; partly because it is not judged considerable enough to need a physician, and partly because as the medicines usually given take no effect upon it. To be able to do any service in this complaint, it is necessary to understand its nature. The seat of a hoarseness is the top of the windpipe or larynx; and the occasion of it is a soreness of that part and a thickness of its natural moisture. This is always perceived by people who are hoarse, for in their endeavours to speak out they find that part of the throat to be sore, and as it were, raw; and if at any time they can bring up a little phlegm it is as thick as jelly, and as tough as glue; and they always speak more freely after this, until more is gathered in the place. Honey is a natural and excellent remedy for this complaint, we have seen in the former chapter how great a power it has of softening and dissolving a tough phlegm; and it is also an excellent balsamic. Reason declares, therefore, that it is most happily suited for curing a hoarseness; and repeated experience confirms it. Persons who are hoarse always are worse in a morning. This is for the same reason that those oppressed with a tough phlegm find most uneasiness at that time. In the night the humours collect themselves, and spread over the part undisturbed; and we feel their effect at rising. This directs the time which must be best for taking honey for the cure of a hoarseness, which is the last thing at night; but it should be repeated also early in the morning; and it may be taken occasionally at any time of the day. In this complaint, the more people strive to speak out, the worse they always make themselves; consequently, without great caution, the disorder will naturally increase. Although night and morning are the times when the honey is most effectual in the general relief of the complaint, it will do service at any time of the day when wanted. Therefore if any one, who is subject to a hoarseness, is sensible that he shall have occasion to speak a great deal, let him prepare for it by taking a spoonful of honey. This will make him speak with more ease to himself, more intelligibly to those who are to hear him, and prevent that straining which is so apt to increase the disorder. At any time when a person who is hoarse is going into company, it will be advisable to take some of this pleasant remedy; and if in the course of conversation he finds his voice grow worse, another spoonful of it will give him that real relief, which he would in vain endeavour to obtain by violent efforts; to speak plainer, this would tend to increase the disorder, the other to its cure. Speaking with ease and clearness must be agreeable to all persons; but there are some to whom it is of the greatest importance. The clergyman who is to officiate in his duty; and the counsel who must speak at the bar, may have occasion often for this assistance; and there are others whose employment, though it be frivolous in itself, yet is important in them, since it gets them breath, such as players on the stage, and singers, who are often distressed in the highest degree by hoarsenesses, which this easy medicine will perfectly cure.

#### USEFUL HINTS.

**SECTIONS.**—These should be often examined, and, as soon as sealed all over, removed. If, however, they are wanted for keeping, it is as well to leave them on until the caps are thickened, to prevent weeping. As they are removed, close up the unfinished ones to the centre and put empty ones, or those partly filled, from hives which seem disinclined to finish them outside.

**STORING SECTION-HONEY.**—Sections of comb-honey should be stowed away in crates (see engraving

on page 56 of *Modern Bee-keeping*), and the air excluded as nearly as possible. The crates should be kept in a dry, warm room, in which the temperature should never be lower than 60° Fabr. All propolis should be removed from the sections, and only those which are perfectly sealed should be stored.

**CONDEMNED BEES.**—If you are likely to be able to obtain these, lose no time in preparing for them. The less work they have to do the better. If you have stocks which from weakness, undue swarming, or other causes, will not give you a surplus of honey, set them to work drawing out foundation and storing the combs with food—either honey or syrup. A few ready-built, or, better still, ready-stored combs given to condemned bees will be a great assistance to them, and be the means of their becoming good strong stocks in the spring.

**UNDESIRABLE SWARMING.**—The late hot weather has been productive of swarms. If preventive measures had been adopted in time we should have heard less of this. (1) The brood nest should have been relieved by the abstraction of full frames and the insertion of comb foundation in their place. (2) Air should have been given freely between floor-board and hive. (3) Plenty of section room should have been provided above, an empty rack of twenty-eight 1 lb. sections being placed under one of the same size when three parts full. We do not approve of caging the queen for the purpose of obtaining increase of honey, looking to the future as well as the present of our colonies.

#### PEEL TESTIMONIAL FUND.

	£	s.	d.		£	s.	d.
<i>Devonshire.</i>				<i>Gloucestershire.</i>			
Rev. A. H. Myles . . . . .	2	2	0	L. Williams . . . . .	0	10	0
<i>Devonshire.</i>				<i>Shropshire.</i>			
Acknowledged . . . . .	0	10	0	Rev. H. J. Wilcox . . . . .	0	5	0
<i>Essex.</i>				<i>Suffolk.</i>			
Acknowledged . . . . .	1	1	0	Rev. A. Leakey . . . . .	0	10	6
<i>Hampshire.</i>				H. Keridge . . . . .	0	5	0
Dr. Blake . . . . .	0	10	6	<i>Surrey.</i>			
E. C. Morgan . . . . .	0	10	6	Acknowledged . . . . .	0	5	0
<i>Hertfordshire.</i>				M. Wood . . . . .	0	2	6
Acknowledged . . . . .	2	9	6	<i>Sussex.</i>			
Mrs. Maynard . . . . .	0	2	6	Rev. V. Astley Roberts . . . . .	0	10	0
Rev. V. Astley Roberts . . . . .	0	10	0	Mr. A. Adams . . . . .	0	2	6
Mr. A. Adams . . . . .	0	2	6	<i>Warwickshire.</i>			
R. Atkins . . . . .	0	3	0	Acknowledged . . . . .	0	15	0
<i>Hants and Berkshire.</i>				<i>Wiltshire.</i>			
Rev. H. Matthews . . . . .	0	5	0	A. G. Radcliffe . . . . .	0	2	6
<i>Lincolnshire.</i>				<i>Norfolk.</i>			
Acknowledged . . . . .	2	2	0	Mrs. L. Brown . . . . .	0	5	0
Mrs. L. Brown . . . . .	0	5	0	Rev. J. L. Sisson . . . . .	0	10	0

#### CORRESPONDENCE BETWEEN MR. HUCKLE AND MR. J. P. JACKSON.

(To the Editor of the British Bee Journal.)

SIR, May I ask the favour of your giving publicity to the enclosed correspondence? The article taken from the *Bee-keepers' Record*, and published in your last issue, imputing mismanagement to the British Bee-keepers' Association Annual Exhibition, casts considerable re-

lection upon myself, and certainly requires a fuller explanation from the editor of that paper.—J. HUCKLE, Secretary of B. B. K. A.

MR. JACKSON to MR. HUCKLE. *June 28th.*

Will you kindly give me the number of votes recorded at the election when Mr. Godfrey, of Grantham, was a candidate? I think you have a record of them, and I should be glad of the information.—J. P. JACKSON.

MR. HUCKLE to MR. JACKSON. *July 2nd.*

I am always pleased to afford every information in my power which is required for the benefit of the cause of bee-keeping, and especially in regard to Mr. Godfrey, who has been one of its best friends. But, bearing in mind the article which appeared in the *Bee-keepers' Record* on June 15 respecting the B.B.K.A., I think I am entitled to ask for what purpose this information is intended to be used. The article was very personal towards myself; and I think the assertion that the shows of the British Bee-keepers' Association have been mis-managed comes with very bad grace from yourself, and will not be endorsed by the exhibitors at our exhibitions. The public will be the best judges as to whether the B.B.K.A. Exhibitions have been mis-managed or not.—J. HUCKLE.

MR. JACKSON to MR. HUCKLE. *July 4th.*

I am sorry to see that you consider the article in the *Bee-keepers' Record* was personal towards yourself, for it was certainly not intended as such. I will have a note to this effect made in the next issue, and will do you full justice, as you will see. I know as well as any one how hard you have worked for the B. B. K. A. and for bee-keeping. My only reason for asking for information re past elections was, that we recently stated Mr. Godfrey had in times past been returned at the head of the poll (excluding the Chairman, of course); and as Mr. Godfrey himself is inclined to doubt it, I want to know the facts.—J. P. JACKSON.

MR. HUCKLE to MR. JACKSON. *July 7th.*

Your note of the 4th inst. is to hand. Your statement in regard to Mr. Godfrey is only partially correct; he was returned next on the list to Mr. Cowan on one occasion, but not so on the others. I venture to hope that you will explain in what respect the B.B.K.A.'s Annual Exhibitions have been mis-managed. The simple statement that the article did not refer to me will not be sufficient.—J. HUCKLE.

[The above correspondence refers to a statement in the *Bee-keepers' Record* of June 15th, that R. R. Godfrey, Esq., of Grantham, at each annual election of the British Bee-keepers' Association used to be returned at the head of the poll! We think it desirable that persons who venture to take upon themselves the office of critics should at least be accurate in their facts.—Ed.]

## ASSOCIATIONS.

### BRITISH BEE-KEEPERS' ASSOCIATION.

Committee Meeting, held at 105 Jermyn Street on Wednesday, July 2nd. Present, Rev. H. R. Peel (in the chair), Hon. and Rev. H. Bligh, Rev. F. G. Jenyns, Rev. F. S. Selator, J. M. Hooker, and the Secretary. Captain Bush, R.N., was unable to be present, owing to illness; and letters were read from Rev. E. Bartrum, Rev. F. T. Scott, Captain Campbell, and W. O'B. Glennie, regretting their inability to be present.

The minutes of the last meeting were read, confirmed,

and signed. The balance-sheet for the month ending June 30th showed a balance in hand of 40l. 0s. 2d. The Secretary reported that the President would be absent from London on the dates named for the Conference, and that her Ladyship had requested Sir John Lubbock to preside. Resolved, That, in the event of Sir John Lubbock being unable to preside, Mr. T. W. Cowan be requested to take the chair. The Chairman gave notice 'That at the next meeting he should move for a return to be made of the attendances of each member of the Committee during the present year.'

Reports were received from the Sub-Committees:—

1. The County Associations' Sub-Committee reporting considerable progress being made towards the formation of County Associations in Wales and the North of England. 2. The Examination Sub-Committee announcing that the correspondence between the Rev. A. Leakey and the Educational Department, as published in the last issue of the *B. B. Journal*, had been duly considered, and that the Sub-Committee had prepared a graduated scheme, and recommended that the same be forwarded to Mr. Mundella, with a memorial soliciting his sanction and support for the teaching of bee-keeping as an elementary science in the National Schools. Resolved, That the report be adopted, and that immediate steps be taken to bring the matter under the notice of the Educational Department.

Votes of thanks were passed to the Hon. and Rev. H. Bligh, the Rev. F. T. Scott, Mr. C. N. Abbott, and Mr. J. M. Hooker, for their gratuitous services in acting as judges at the Maidstone and Guildford Shows.

Mr. J. M. Hooker was appointed to act as judge at the Wiltshire Show on August 13th, and the Rev. F. S. Selator at the Staffordshire Show on August 26th.

The next Committee Meeting was fixed for Friday, July 25th.

### HERTFORDSHIRE ASSOCIATION.

The Herts Association has arranged two exhibitions of honey, &c., this year, the first of which took place at Hitchin on the 9th inst., in connexion with the Hitchin Adult Schools' Horticultural Show. The exhibition of honey was a grand one, some seven or eight hundred pounds being staged, Mr. Gulston, of Kings Langley, securing the British Bee-keepers' Association's silver medal with a magnificent display of 250 pounds. Mr. Daws, of Ware, also showed several first-class exhibits amounting to 150 pounds weight. The majority of the classes were allotted to artisans and labourers, and the Hon. Sec. (the Rev. J. Lingen Senger) is to be congratulated upon the success of the exhibition.

A visit to the Hertfordshire Show would have promptly removed all doubts as to whether labourers can be taught to profit by the better methods of bee-keeping. Although a minor county, the Herts Bee-keepers' Association now numbers nearly 500 members, including a large number of artisans and labourers.

The Rev. F. S. Selator, the Rev. F. G. Jenyns, Mr. A. Lipscomb, and Mr. J. P. Sambels, acted as Judges, and their awards gave general satisfaction.

### WILTS BEE-KEEPERS' ASSOCIATION.

The above Society held its first exhibition of the season at Marlborough, June 17th and 18th, at the invitation of the Marlborough and Pewsey Vale Agricultural Association. The weather, though threatening at first, improved the second day. No prizes were given on this occasion, it having been determined to reserve them for the County Show to be held in August with the Keevil District Horticultural Society's, when an examination for Experts will be held by the British Bee-keepers' Association, who will also appoint judges. All particulars relating to these events may be obtained from the Hon.

Sec., Rev. W. E. Burditt, Buttermere Rectory, Hungerford. At Marlborough, a convenient site was allotted to the Bee Exhibition Tent, measuring some forty-five by twenty feet, the enclosure for driving being on one side. The manipulations were carried out and lectures given by the Experts of the Association in turn at frequent intervals. Messrs. E. M. Hart, Longstock, Hants, made a good show of thoroughly useful and economical bee-furniture, and the Hon. Sec. helped fill the tables with a miscellaneous collection, among which was a small observatory hive, with bees working in it, which attracted much attention. H. Huish, of Patney, Devizes, and G. White, of Bagshot, near Hungerford, showed some excellent flat straw slops, which with the 'Buttermere Crate' (some of these were exhibited by Messrs. Hart, also by A. Stratton, of Woodborough, at a very low price, within reach of cottagers), containing eighteen 1-lb. sections, is certainly the best style of hive for cottagers, and those who do not wish to have much to do with their bees *beyond eating their honey*. A small quantity of honey was exhibited in sections by Rev. E. Davenport and Mr. E. Holliday, and some extracted honey in 1-lb. bottles by Rev. C. W. Honey, of Bishops Cannings, and Rev. W. E. Burditt. Mr. Coleman, naturalist, &c., of Marlborough, secured some capital old stocks of bees for driving. The Exhibition Tent, an excellent one for the purpose, was provided by Mr. John Corp, of Clatford. It is to be hoped that those members who have not yet paid in their subscriptions will do so without delay, and also add a trifle towards the Prize-Fund for the County Show, as until all these are in hand the amount of prizes to be offered cannot be fixed. At the County Show the Silver and Bronze Medals and Certificates of the British Bee-keepers' Association will be competed for as usual, the other prizes depending on the amount subscribed for the purpose. Advertisements of the County Show and Honey Fair will appear in due course.

#### NORFOLK AND NORWICH BEE-KEEPERS' ASSOCIATION.

This Association held its Annual Show on Thursday, the 3rd inst., in the beautifully picturesque grounds of Moushold House, Thrappe, by the kind permission of W. H. Hackblock, Esq., about a mile distant from the fine old city. A more delightful spot, a more brilliant day, and a kinder, heartier-welcome than that afforded, both to officials and visitors, could not be desired by the managers of this flourishing Association.

The exhibits also, especially the fine and extensive display of comb and extracted honey, were far in advance of former years; and we pitied the judges who had to decide in these classes, where the competition was so keen that a mere trifle turned the balance in several cases.

We append the prize list, merely remarking that we thought Mr. Barge's collection of bee-keepers' appliances well deserved its award of first prize, Messrs. Abbott coming in a good second.

The Rev. George Raynor, assisted by the Committee, awarded the prizes, and we were pleased to notice that the awards appeared to give general satisfaction on all hands. The whole exhibition, in fact, was admirably carried out, under the superintendence of its indefatigable secretary, Mr. H. K. Funnis, who certainly held no sine-cure office during an almost Indian heat.

**Bees.**—For the best stock of Ligurian, or other Foreign Bees, and for the best stock of English Bees—S. Barge, Yarnouth.

**Hives.**—For the best, most complete, and serviceable Hive for this county, on the moveable-comb principle, to include covering, stand, floor-board, and facilities for storing surplus honey—1. J. Blake, Ipswich; 2. Abbott Brothers, Southall; 3. S. Barge. For the best, most complete, and serviceable Hive for this county, on the

moveable-comb principle, for cottagers' use, to include covering, floor-board, and facilities for storing surplus honey, price not to exceed 10s.—1. J. Blake; 2. S. Barge; 3. Abbott Brothers. For the best Straw Hive, with facilities for storing comb honey in sections—1. T. B. Blow, Welby; 2. S. Barge. For the best Frame Hive for general use—the work of an amateur or cottager, being members of the Association—1. A. C. Stead; 2. R. Moore, Norwich. For the neatest and best Supers, complete with racks and sections for producing honey in the comb in the most saleable form—1. Abbott Brothers; 2. S. Barge; 3. Abbott Brothers. For the best and most complete collection of Hives, Extractors, Smokers, Feeders, and Bee Furniture, no two articles to be alike—1. S. Barge; 2. Abbott Brothers.

**Honey.**—For the best exhibition of Super Honey from one apary—3. Rev. J. J. Cumming, East Carleton. For the best Super of Honey, the super to be of wood, straw, or of wood in combination with straw—1. Rev. A. F. Bellman, Moulton; 2. H. Bartram, Hasbro'; 3. Miss Pell, Topcroft. For the best twelve 2-lb. sections of Honey in the Comb—1. Rev. Lawson Sisson; 2. Mr. Stead, Nocton; 3. Rev. L. Sisson. For the best twenty-four 1-lb. sections of Honey in the Comb—1. Rev. L. Sisson; 2. G. R. Kingston, East Dereham; 3. W. Cooke, Aldborough. For the best twelve 2-lb. Glass Jars of extracted Honey—1. Rev. A. F. Bellman; 2. Mr. A. C. Stead; 3. Mrs. A. Kendle, Wenshanam. For the best twelve 1-lb. Glass Jars of extracted Honey—1. A. C. Stead; 2. Rev. A. F. Bellman; 3. Rev. E. Farrer, Bessingham. For the largest and best collection of extracted Honey in Glass Jars—C. W. Middleton, Hellesdon.

#### COTTAGERS' CLASS.

*For Members of the Association residing in the County.*

For the best Frame Hive for general use, the work of a cottager, being a member of the Association—1. R. Moore, Norwich; 2. H. Dobbe, Thickthorn.

For the best exhibition of Honey in the Comb, taken from one hive, without destroying the bees—open to *hand file* cottagers only—H. Bartram, Hasbro'.

For the best Super of Honey, the super to be of glass, wood, straw, or of wood in combination with straw—open to *hand file* cottagers only—1. R. Howes, Buckenham; 2. C. Hoyle, Buxton; 3. H. Bartram.

#### HEREFORDSHIRE BEE-KEEPERS' ASSOCIATION.

ANNUAL SHOW AT LEIGHTON, JUNE 24th, 25th, and 26th.

This was held in connexion with the Herefordshire Agricultural Show; it was favoured with fine weather, and proved an entire success. There was a good competition in the hive classes, Messrs. Abbott and several other makers from a distance competing. There was also a capital show of honey, as, although but small prizes were offered, it being so early in the season, about six hundredweight was staged.

There were several important innovations at the Show, perhaps the most important being the

#### MICROSCOPIC SHOW.

This was held in a special, manipulating tent, the microscopes (twelve compound and ten simple lenses) being placed on tables ranged round the central opening. The bees for manipulating were kept within the inner walling of this tent, and a large observatory hive at the entrance had also its flight-hole under the netting. The objects shown were parts of the bee, such as pollen-basket, wing, foot, sting, eyes, wax-pockets, &c.; also pollen, fructifying parts of blossoms, flake of wax, queen, drone, and worker mounted whole, and tongues of black and Ligurian bees side by side with red and white clover tubes.

The exhibit proved an entire success, several hundred visitors seeming to take a great interest in the objects. It was found that two, and if possible three attendants were necessary to explain the objects; Mr. J. E. Bullard took chief charge of this department, and explained the anatomy of the bee with great energy and success.

On the first day of the Show the microscopic tent was open free, but it excited such interest as entirely to spoil the attendance at the adjoining manipulating tent. On the following days, therefore, the two tents were combined by means of a wide canvas corridor, and a charge made for admission to the two. This arrangement worked well, as visitors were not kept waiting, but occupied the intervals at the microscopes.

Most of the objects were provided by Mr. Alfred Watkins, the hon. sec. (who organized the whole of the Bee Show). Messrs. Abbott Bros. kindly lent a beautiful series of slides, but it was found that the more simple objects for use with low powers were most suitable. The microscopes were all lent by gentlemen in the county.

Hive-making was another attraction, a local straw-hive maker being busy at work all three days making flat-topped, straw hives. An exhibit of bar-frame hives was also arranged. The saw-bench, with materials and tools, and two hive-makers, were certainly present, but as very few persons saw them at work, their proceedings did not excite much interest.

#### THE CONVENTION.

This was held on the Show Ground at 11.30 in the morning of the third day; the attendance was not large, but each question was fully ventilated. The programme was as follows:—

1. The advantages, disadvantages, and best method of stimulating by feeding: introduced by Mr. A. Watkins. 2. The advantages and disadvantages of Ligurian *versus* English bees: introduced by Mr. Thomas Haywood. 3. Bar-frame hives *versus* skeps for profitable bee-keeping: introduced by Rev. F. S. Stooke-Vanhan. 4. Wintering bees: introduced by Rev. J. E. Sale. 5. Packing and marketing honey: introduced by Mr. J. Grant.

The Rev. J. E. Sale took chief charge of the hive and honey show on each day. Col. Pearson, of Downton, Kingston, and Mr. C. Brown, of Bewdley (the expert to the Worcestershire Association), kindly acted as judges.

We hope that the first Honey Fair, which they propose to hold at the Butter Market, Hereford, in the autumn, will have as great a success as their L. & B. Show.

The following is the list of awards:—

**HIVES, ETC.**—Class 1.—For Frame Hive, of a substantial character, with Crate of Supers complete. Price not to exceed 15s.—First prize, 15s., Messrs. Abbott Bros. London; 2nd, 7s. 6d., Mr. J. Hole, Tarrington. Class 2.—For Frame Hive, with Crate of Supers complete. Price not to exceed 10s. 6d.—First prize, 15s., Mr. E. C. Walton, Newark, Notts; 2nd, 7s. 6d., Mr. G. F. Harrison, Hales Owen; 3rd, Mr. J. Hole. Class 3.—For Flat-topped Straw Hive, of the size approved by the H. B. K. A., viz.: sixteen inches across and nine inches deep, inside measurement.—First prize, 7s. 6d., Messrs. Abbott Bros.; 2nd, 5s., Mr. W. Price, Aylton, Leicestershire. Class 4.—For the Best Crate of Sectional Supers, with Roof complete, suitable for using with the Association straw hive.—First prize, 7s. 6d., and 2nd, 5s., Mr. Thomson, 20 High Street, Birmingham. Class 5.—For the Largest and Best Collection of Hives and Bee-Furniture, applicable to modern bee-keeping.—First prize, 40s., Messrs. Abbott Bros.; 2nd, 25s., Mr. Thomson.

**HONEY.**—Class 6.—For the Best Exhibit of Honey in the Comb; sectional supers preferred.—First prize, 10s., Mr. W. J. Grant, Hope End (90 lbs. of honey); 2nd, 7s. 6d., Mr. Frank James, Hereford (66 lbs. of honey); 3rd, 5s., Mr. T. Charles; highly commended, Mr. Meelham, Huntingdon. Class 7.—For the Best Exhibit of Run or Extracted Honey, in Glass Jars; 1-lb. size preferred.—First prize, 10s., Mr. T. Charles (120 lbs. of honey); 2nd, 7s. 6d., Mr. Meelham (65 lbs.); 3rd, 5s., Rev. F. Stooke-Vanhan.

#### BEE-KEEPING IN WALES.—CARDIGANSHIRE BEE-KEEPERS' ASSOCIATION.

R. F. Gower, Esq., of Castle Malgwyn, to whom the county is already deeply indebted, has been interesting

himself in the formation of a Cardiganshire Association, and, it is needless to add, with success. A preliminary meeting was held at Cardigan on the 21st June, when all present were enrolled as members, and promised to exert themselves to make the movement a success. I think I may safely add that the Rev. Thos. Jones, the Vicarage, Cilgeran, will be glad to supply further information to any one interested. I hope volunteers will soon be forthcoming to assist in removing entirely the black spots from the map of Wales.—L. OSWALD LEWIS, Hon. Sec. *Cardiganshire B. K. A.*

#### HONEY REFRESHMENTS, AT THEALE, BERKS.

On July 1st, at Westeria House, Theale, a room fitted up as a reading-room with papers and magazines, and as the beginning of a Church Institute in Theale parish for young men and others, was opened out. After the formal proceedings of opening, by the rector, Rev. T. Butler, Rev. F. J. Pentecost, and others, were over, the invited company of ladies and gentlemen, parishioners and others, partook of light refreshments which had been provided by the host, Rev. V. H. Moyle. The tables were well supplied with edibles and beverages, but there was nothing therein but contained genuine honey in some form. The now celebrated 'Honey Drops' biscuits of Messrs. Hantley and Palmer in abundance; also 'Honey Ices'—delicious; 'Honey Queens,' 'Honey Fingers,' 'Honey Slabs,' 'Honey Sandwiches,' 'Honey Biscuits,' &c., from Mr. J. D. George, confectioner, Reading; Messrs. Blatch's Honey beverages (non-alcoholic), 'Honey Nectar' and 'Honey Lemonade,' and Honey wine and Honey mead by Mr. A. D. Woodley, of Reading, and Mr. M. Whittle, of Lockinge, Wantage.

#### BEE-TENT ENGAGEMENTS FOR JULY IN ADDITION TO THOSE ALREADY GIVEN.

##### SUSSEX BEE-KEEPERS' ASSOCIATION.

July 23.—Dane Hill.  
July 25.—Stinford, Horsham.

##### BUCKINGHAMSHIRE BEE-KEEPERS' ASSOCIATION.

July 24.—Stony Stratford.  
July 24.—Winslow.  
July 29.—Buckingham.  
July 31.—Chesham.

#### THE JUNE BERRY. (AMELANCHIER CANADENSIS.)

This is certainly one of the finest of early flowering trees, and is not nearly so well known as it deserves to be. London concisely sums up the merits of the June Berry as follows:—'A very ornamental tree, from its profusion of blossoms early in April, and from its rich autumnal foliage; and even the fruit is not altogether to be despised, either eaten by itself, or in tarts, pies, and puddings. The wood is white, and it exhibits no difference between the heart and the sap. It is longitudinally traversed by small bright red vessels, which intersect each other and run together—a physiological peculiarity which, Michaux observes, occurs also in the Red Birch.' In a wild state it occurs from Hudson's Bay, south to Florida, and west to Nebraska and the Indian territory. The wood is exceedingly hard, heavy, and strong. As might be expected from a tree spread over so wide a geographical area, the June Berry varies considerably in size and habit. Under favourable conditions it attains a height of 40 feet. Some notes respecting a fine specimen at Dane Lodge, Epping, are now before me. This tree is 32 feet in height with a head about 18 feet in diameter, the trunk being 7 feet high and 4 feet in circumference. The effect of such a tree in spring, with its mantle of snowy white blossoms, and in autumn, with the rich golden yellow of the decaying leaves, can

easily be imagined. The fruits, which are of a purple colour, are collected in immense quantities on the Upper Peace River, and form quite an article of food and trade. An American writer says that when he was at Dunvegan, the Indian half-breeds were caught out collecting the berries, then in their prime (August 6). They are pressed by the Indian women into square cakes, and used, dried, by the Hudson Bay Company in pemmican. It is almost needless to say that the June Berry is perfectly hardy in this country. It is easily propagated, either from seeds or by grafting on the apple stock. At its northern limits the ground is frozen for the greater part of the year.

Besides the name of June Berry, the *Amelanchier canadensis* is also known in the United States and Canada as 'Shal bush,' 'S-rvice tree,' 'Indian Pear,' 'Sugar Plum,' in addition to its Indian appellation, 'Suskatum.' G. NICHOLSON.

## Correspondence.

\* \* \* All Correspondents forwarding Letters for insertion in the Journal, Reports of Associations, News, Matters of Bee-keeping from the Home, &c., &c., and requests for editorial correspondence to 'The Editor of the British Bee Journal' at Messrs. Strain's, 4, St. Paul's Churchyard, Upper St. Martin's Lane, W.C.

### HONEY AND WAX DEPOT.

Without a doubt, it will conduce very greatly to the interests of British bee-keepers if as many manufacturers as possible adopt the use of genuine British honey and wax; and with a view to this, after establishing the Honey and Wax Depot, and getting Messrs. Huntley and Palmer to use enormous quantities of genuine British extracted honey weekly in the manufacture of their justly famed 'Honey Drops,' I am glad to say we are taking a further step in advance, for now we not only have a firm of world-wide and reliable reputation making these articles of food for home consumption, which are also being largely shipped to the colonies and elsewhere; but on Monday, June 23rd, 1884, there were first brought out at the British Bee-keepers' stand at the Health Exhibition some 'Honey Beverages' which being effervescent and non-intoxicant are simply delicious.

They are entitled 'Honey Lemonade' and 'Honey Nectar,' and are manufactured by my friend and neighbour, Mr. F. Blatch of Theale, Berks. Mr. Blatch is a bee-keeper and member of the Berks B. K. A., and having extensive business premises, and all appliances for the manufacture of aerated water and other kinds of beverages, is preparing to supply them largely to the public. Terms on application to him. He deserves the thanks of bee-keepers, generally, for acting on my suggestion and utilising *pure British honey* in pleasant and wholesome beverages like those, as Messrs. H. and P. have done in bottles. By-the-by the *Lancet*, of June 7th, has a very kindly notice of the 'Honey Drops' as the first large effort to utilise in this shape genuine unadulterated British honey.

These biscuits and drinks may be seen and tasted at the British Bee-keepers' Stand at the Health Exhibition, and I have got placed there, by kind permission, sample bottles of each or either, by two of our Berks B. K. A. members, viz., Mr. A. D. Woolley of Reading, our esteemed expert, and Mr. Whittle of Locking.

I hope also to exhibit similar applications of honey, &c., at the Annual Show of the Royal Agricultural Society (of which I am a member) at Shrewsbury, and to be there myself to explain them to visitors.

If at this time of the year hay is to be made while the sun shines, we bee-keepers must copy the bee and lose no opportunity of deepening the interest already increasingly felt by the general British public in the

applied forms of honey and wax.—V. H. MOYLE, *Brook House, Burghfield, near Reading.*

### WESTMORELAND.—AN APPEAL.

I gather from the map published in a late issue that Westmoreland is the only county (with the exception of Rutland in England) which is doing nothing towards the formation of a Bee-keepers' Association. Is there no one in Westmoreland who takes sufficient interest in the welfare of the county as to devote a little time and trouble towards giving the Westmoreland cottager as good a chance of increasing his income as is afforded to the cottagers in all the other English counties?—WINDERMERE.

### BEE-KEEPING IN LINCOLNSHIRE.

Since the Lincolnshire Bee-keepers' Association was first instituted, in 1875, I have noted its doings with much pleasure, and have watched with considerable satisfaction its progress. The first honey-fair under the auspices of the Association was held at Grantham in September, 1877, when nearly half-a-ton of honey was staged and most of it sold—a result which at that day was considered by the managers very satisfactory. At the annual fair held in October last, however, no less than two tons three hundredweight of honey (the produce of bees kept by the members) were on sale, and the greater portion changed hands at good prices, large lots going to London, Liverpool, Derby, and other centres. To further instance the work this Association is doing, I have before me a statement, which I am privileged to give publicity to, in reference to one of its members, viz., Mr. J. H. Brown, of Swinshead, whose yield of honey during last year reached the enormous weight of 1776 lbs., the whole of which he has sold at an average price of one shilling per pound net. I would remark that Mr. Brown was first impressed with the importance of bee-culture by a visit to one of the meetings of the Association in 1880. He is a large owner and occupier of land, and evidently derives both pleasure and profit from the addition of bees to his other stock. I think, also, that he is alive to the value of bees as fertilising agents in connexion with his seed crops. As it, to cite an instance of what may be done by cottagers who will help themselves—which they may do by keeping a few stocks of bees—I can refer to one who, from the profit of bees, was enabled to discharge a heavy doctor's bill, carpet the parlour, furnish it with a looking-glass, educate an adopted child, and enjoy a change of air at Skigness. Turning to another station of life, mention might be made of a young lady, the daughter of a much-respected vicar in my own neighbourhood, who is quite an expert in the management of bees, handling them without veil or gloves, regardless of any vacillating propensities they may exhibit! This lady has realised a sum of £10, in one year from her bees; and at the last public sale her stock of honey and wax was secured by an old judge as soon as the fair was proclaimed. As one other instance of the extent to which bee-staffing is now being carried on in this county, it will be of interest to state that Mr. R. Thorp, late of Evedon, in a single transaction last season, sold bees and hives to the amount of a little short of 1000, and still farms some eighty or ninety stocks. Such facts may appear startling to the uninitiated, but they are no less true. Very many other large apiaries exist in various parts of the county, and reports show that, as a honey-producing county, Lincoln is one of the best, if not the best, in England. Yet there are thousands of stocks of bees needed to gather in the tons of otherwise yearly wasted sweet, delicious nectar; and anything that can be done to advance the interesting and profitable system of bee-keeping is deserving of support and encouragement.—A LINCOLNSHIRE APIMARIAN.

## BEE-KEEPING IN LINCOLNSHIRE.

Reports in this district are varied as to losses this spring, several skepists have lost heavily, also one bar-hivist, who follows the let-alone principle. I have inspected a friend's apiary, and find his seventy stocks strong and full of brood; he has secured about 25 lbs. of honey per stock already. Mrs. Brown Whaplood's twenty stocks lived through the winter and are doing well. Hearing of a farmer in an adjoining parish, who had one skep which had swarmed three times a fortnight since, I went to look at it; and judge my surprise to find it under a plum-tree close to the house, covered by two pan-tiles, and the tree grating upon it, the pressure having broken the floor-board, exposing two inches of the combs, also a crack one inch wide in the middle, the bees passing in through both openings giving abundant ventilation, but proving the fact that bees breed well if kept warm and tight at top of hive, which prevents upward ventilation during the summer; and the few losses I and my friends who have placed wheat-chaff upon stocks in winter, giving upward but gradual ventilation, cause us to think it best.—R. TITORER, *Langrick Ville, near Boston.*

## HINTS FOR AMATEUR HIVE-MAKERS.

1. No matter what any one tells you, hinge the roof to the hive-body. Use butt hinges with loose joints, and you can then slide off the roof when you please.

2. Use a stay to support the roof in a perpendicular position, so that you can have a handy place for smoker.

Take two pieces of keeve-hoop iron, 12 inches or more in length and 1 inch broad, and rivet them together at one end, but not so tightly as to prevent them moving. Have holes in the other ends for screw nails, and affix one end to the roof and another to the hive-body. If the sides of hive are higher than the frames, you can put the stay inside, and by screwing one end of it about two or three inches from bottom of roof wall, the stay when the hive is closed will be out of the way of any packing over frames, &c. Fix the stay at a very obtuse angle, and so that the joint will be next the hinged side when the roof is down.

3. Let three sides of your hive be at least two inches higher than the frames. Let the fourth side slide down into its place through a groove at ends of two opposite sides. The fourth side, sliding in this way, should be at one end of frames, and it can be easily withdrawn when you want to slide on a crate of sections. By having a sliding end you do away with the objection to high-topped hive-bodies, viz., that you cannot put on sections without crushing bees. The great uses of this kind of hives are, that there is no danger of the quilt being blown off when feeding, you have more room for sections, you can pack sections closely with cloth or flannel, and the cold does not enter directly at the quilt. Tack strips of zinc on the ends and bottom of the fourth side, so as to throw off rain.—APICULA.

## NOTE ON TRANSFERRING.

I have, in transferring, used with advantage common India-rubber rings, instead of tapes. They are easily and quickly slipped over the frames, with their included combs, which they keep in their place. They require no tying, and, after they have served their purpose, are slipped off in an instant.—F. G. S., *Churchdown Vicarage, Gloucester.*

[We are pleased to give insertion to the above. But this use of India-rubber rings is no novelty to experts at shows when driving and transferring.—Ed.]

## VITALITY OF THE BEE.

Last week, when examining one of my hives, I accidentally sharply cut the head of a bee clean off with a section separator. To my surprise it exhibited no signs of pain, but moved about, of course aimlessly. I brought it into the house on my hand, and watched its movements for a considerable time. It moved about, and repeatedly rubbed its hind legs together and kept passing its front feet over its headless neck, occasionally buzzing its wings. I left it for forty minutes, and on my return I found it as lively as ever, and offered it my finger to walk on, which it availed itself of and immediately gave me one of the severest stings of very many that I have experienced. This to me is very curious and interesting; and I am at a loss to understand how the bee without its head should know the right time and place to use its weapon; for until irritated and in contact with me concurrently it did not try to sting, though it had been both separately for some time before.—H. W. HARDY, *Heaton Mersey.*

## BEES BREEDING IN HORIZONTAL COMBS—REVERSIBLE FRAMES.

Some time ago there was a little discussion regarding the utility of reversible frames, and if I remember rightly, Mr. Cheshire said, when combs were reversed, the bees nibbled them down to the midrib and then rebuilt them afresh; and this argument or statement seemed so probable and reasonable to suppose that reversible frames have been quietly dropped in this country. In America such is not the case, but from reports they are being used with success, though I think they might be turned to more advantage in this country, to force the bees to extract or remove the heather honey from the old dirty combs to the clean sections above, and thus solve the problem of extracting heather honey.

The other week I read, in the *American Bee Journal*, of bees breeding in horizontal cells; quite sceptically I laughed, and remarked, 'What next? I'll tell that to the horse marines;' little thinking, in a week's time, I should be satisfied of the fact.

Well, yesterday afternoon, July 7th, I was transferring a skep the combs of which at one time—not recently—had broken down; one comb lay in a perfectly horizontal position, about four inches from the bottom of the hive, which was full of brood on both sides, in all stages of development; thus on one side the brood was head downwards, on the other head upwards. Let Mr. Cheshire or any one else now come forward and disprove the possibility of bees breeding in any inclination or position, and perhaps Mr. Haviland will be inclined to think bees and wasps may have had one origin, since wasps breed head downwards, are nearly the same shape, and some kinds nearly the same colour; it seems more probable than that humble bees and hive bees should have had one.—JOHN HEWITT, *Sheffield.*

## VAGARIES OF BEES.

Being much interested in bee-keeping, and in reading your valuable *Journal*, I send the following account of the 'vagaries' of bees: I have seven stocks of bees—Ligurians and blacks; both in bar-frame hives and in skeps—and on the 10th of this month (June) one of the Ligurians threw off a cast, which was cleverly lived by a lady (her first performance) in my absence. When I arrived at the apiary, about one o'clock p.m., I found 'the cast' nicely placed on a large sheet in a skep, with a stone under the side, and the bees collected within, seemingly quite satisfied with their abode. About a quarter past one a swarm came out from a hive of blacks, and settled in an apple-tree just over the place where the cast was on the sheet. I went up and shook the swarm of blacks into a skep, and placed them also on the same sheet with

the east, but some distance from it. The bees on coming down to join the swarm mistook the hive, and went into the one with the Ligurian cast. Shortly after—about an hour—the east of Ligurians came out, deserting their hive, and settled on the top of a pear-tree (very high). While waiting for them to cluster, I moved the black swarm to a stand between two Ligurian stock hives—the only place I had vacant at the time—and went to take down the Ligurian cast from the top of the pear-tree, which I did with much difficulty. I was quite satisfied that all was now right, and I went over to see how the black swarm was getting on. I found that a few stray Ligurians about the front of the hive were trying to get in, and rather a lively ‘discussion’ was going on between the different ‘nationalities.’ This was about five o’clock p.m. I had just turned away to perform some other work in the apiary, when all the black bees came rushing out and swarmed again, or, rather, I should say clustered, on the tree where they had settled before. I went to the hive and found it empty. Like Pat, I scratched my head, and began to think whether I would again have to go to the trouble of re-living them.

But they saved me any more thinking; for, after remaining a minute or two on the tree, they went straight back again into the hive, between the Ligurian stocks (the one in which I had first placed them). Having nicely settled in, I moved them to a new stand, hastily made of an old apple-barrel, and there they are now as busy as bees.

Now, sir, I have seen it stated in bee books and journals that swarms coming off together often amalgamate, or words to that effect. It was quite evident that mine did not, and I am of opinion that the blacks fighting with Ligurians, and *vice versa*, caused in the first instance the Ligurians to quit, and in the second the blacks to follow their example. The extraordinary part of the performance to my mind was the blacks again coming back to the hive in which they were originally placed. The point I would like the opinion of an old ‘bee-master’ upon: if one should read these lines—is it possible in any frame hives to prevent Ligurians’ swarming three or four times? I have a hive of Ligurians that swarmed on the 23rd of May, again on the 6th of June, when I removed or caught the queen, and sent swarm back to its own hive. They again swarmed the day after, and I lived that ‘bolt.’ I have no doubt about not taking the queen from second swarm or ‘cast,’ as I have her at home ‘laid out,’ with a pin through her body, as a sample queen.

With regard to the question of blacks *versus* Ligurians, after an experience of three years in bee-keeping, for honey-making in this country, I would sooner have one good colony of blacks than *three* of Ligurians.—J. G. B., 13 Conyngham Road, Dublin.

#### AN ERRATIC SWARM.

On Thursday, the 12th June, whilst absent from home, a hybrid-Ligurian stock sent off a first swarm. On my return at 12.20 p.m., I found the swarm on the main stem of a standard apple-tree, near the top. I have no means of judging how long the bees had clustered, but, as they were quite quiet, I presume they had swarmed about an hour before I found them. I tried to fix a skep above them but did not succeed. Then I rather hastily tried to shake them into the skep, and shook them down among the leaves. Immediately the swarm took to flight, and slowly flew down the High Street, to the admiration of all in the neighbourhood. After circling round for a quarter of an hour they got under the roof of a tradesman. At night, with the kind permission of the owner, I mounted under the roof and with great difficulty secured about half of the bees, hoping I had secured the queen. I left the bees in the skep all night, and on the following morning at 10 o’clock, I found the bees quiet, a few bees passing

in and out. I put on a feeder, and was just going away when at 10.15 the bees began to pour out of the hive, and sport themselves in the sunshine. They quickly however settled on a currant-bush, and at 10.45 I successfully lived them in another skep, and left them near the bush on which they had settled. At one o’clock, and again at four p.m., I visited the bees, and found them passing freely in and out as is usual after living a swarm. I left them with every confidence of having no further trouble, and at seven o’clock, I gave them a passing look to see if they were settling down for the night. This last visit was merely a glance, as I said, and seeing one or two bees hovering about the hive, I made sure all was right. However, what was my surprise and disgust at 8.45 when I went to move the hive to its destined position to find that the hive was empty! Some time certainly after four o’clock, the bees had finally taken their departure; and although I have made inquiries I have found no one who saw them depart, or could tell me any thing about them. I may add that I visited the roof a second time to make sure that the bees had not returned, and found the place quite deserted.—F. C. Stone.

#### BEES SWARMING.

On June 2nd (Whit Monday) a stock of Ligurians sent off a swarm unobserved, which was found about 6.30 p.m. clustered on a currant-bush and close to the ground. I was confined to my bed and unable to do anything, my gardening lad had gone home, and there was nobody near who could or would come near a bee. After consultation my wife and house-maid volunteered to try their hand, although neither had ever done anything more than look at bees. They soon had the swarm into a skep, and left them for the night. The next morning my lad put the swarm into a frame-hive, with seven frames of comb-foundation; and so they were left until the 22nd of June, when, for the first time, I was able to do anything, and I had a look at the swarm, expecting to find the old queen, but, to my surprise, I found a fine young, vigorous queen, which had filled the frames with brood and eggs. I was too weak to do more that day, so left them and began to wonder at the cause. I ought to have stated that the queen in the original stock has her wings so closely clipped that she could not fly, and from that cause I attributed the swarm settling so near the hives and so close to the ground. The following day I looked at the original stock, and on taking out the third frame I saw the old queen. I looked carefully through the whole of the frames, and could only find *one* queen-cell, and from which a queen had hatched. When I the day before found a young queen with the swarm, I concluded that the bees had superseded the old queen for some reason or other; and yet, as I had only had the queen from Mr. Simmins last year, I could not fancy she had been superseded from old age, as she has proved most prolific. On finding the old queen in the original stock I was more surprised than before, as I have never heard, neither have I read, of a case of swarming with a young queen leading and leaving the old queen behind. The only way I can account for it is, that the bees, knowing the queen could not fly, and, I suppose, being satisfied with her laying powers, decided to rear and send off a young one with the swarm. However, whatever their ideas may have been, I send you the facts for your insertion in the next issue of the *B. B. Journal*, if you think them worth notice. WILLIAM BUSH, Captain R.N., Paradise Lodge, Harlow, Essex.

#### FREAKS OF BEES IN SWARMING.

The bees of this district have been indulging in some whimsical conduct in the matter of swarming. It is not surprising that two swarms should join, but that a succession of swarms should do so, and that over an area of

four or five miles in diameter during the whole swarming season, must have a reason of which we are not yet aware. In my own apiary two joined in the air and lighted together on an espalier forming a huge column from top to bottom of the rail. The second swarms from the same hives came out on the same day; the first was only just safely hived when the second issued, and at once joined the others in the same skep.

On another occasion two first swarms issued at an interval of an hour. They were secured in separate skeps, but when I went to hive them in the evening, the second corner had left its skep and was safely lodged with its neighbour.

Another day I had just housed a first swarm, and they had become quiet when another issued, and after wheeling about in an undecided manner, some of them returned home and the rest made straight for the newly hived lot. They had only just settled in when a third large swarm issued, and without loss of time proceeded to the same skep. It seemed to make no difference to them that the skep was already full to hold them all; a large cluster took possession of the umbrella used for shading the skep; others nested in the folds of the sheet employed for the same purpose. I happened to have a huge Pettigrew skep large enough to contain nearly a bushel, into which I then turned them, and they are now working in it magnificently.

A neighbour, two miles east of me, had a cast from one of his hives; shortly afterwards a cast issued from another, and flew at once into the former, where they were welcomed without ado. After they were settled in, the first cast conceived the idea of returning to their stock, and so there were three colonies happily combined. The owner sought my advice, and I recommended him to raise the hive from the floor and give them air, and put on a super and make a grand harvest from them. He did so, but the day after one colony started out again, and the next day the other.

About the same distance west of me some beginners report similar freaks amongst their stocks; and these instances do not exhaust all that have occurred in this district. Perhaps you may think it worth while to record these notes in your fittings.—H. G. W. AUBREY, *Hole Rectory, near Salisbury, June 30th.*

#### MOST CONVENIENT BEES.

We read lately of a swarm settling in their owner's hat, and allowing him to carry them home conveniently, but a swarm in this neighbourhood has been still more accommodating.

My bees had been rather a failure, the stocks having dwindled down last winter, and my cousin, a successful lady bee-keeper, living half-a-mile off, was most anxious to give me a swarm. As her best hive showed no signs of such intentions, she was very urgent that I should take the bees from half her frames, this I would not hear of, not wishing by any means to weaken her stock.

On the 24th inst., however, a fine swarm left the hive without her knowledge, and no one could give any account of their whereabouts, until the following evening, when it was discovered they had taken possession of an empty bar-frame hive standing in my garden, and had already done considerable work.

The strange part of the occurrence being that the bees had gone exactly where they destined to be sent.—A. F. CARLTON, *June 26th.*

REV. C. H. SPURGEON A BEE-KEEPER.—A recent number of the *Pall Mall Gazette*, in an article entitled 'Spurgeon at Home,' informs us that in the reverend gentleman's garden 'there is a fountain with gold fish, and any number of bee-hives, for Mr. Spurgeon is a great aparian, and loves to hear the murmur of his bees as he strolls through his small domain.'

#### A STRAW SKEP AT LEAST TWENTY YEARS OLD.

There are few members of the Lincolnshire B. K. A. that have passed the old Mause, 'an oasis in the desert,' of Whapload Drive, who were aware that the Rev. R. Hollis had for so many years kept such an excellent stock of bees. I found a straw skep twenty years old, 'at least,' and it was working well and strong; and the whole of his stocks, about twenty, demonstrate the utility of keeping them strong, combined with liberal feeding, in the strong swarms they produce. He does not work them much for honey, in consequence of there not being a ready market for the sale of it. A good market would be a great boon to all bee-keepers.—ROBT. THORPE, *Langrick Villa.*

#### LANCASHIRE AND CHESHIRE BEE-KEEPERS' ASSOCIATION.—A COMPLAINT.

It may not be out of place to lay my case before you in reference to two prizes that I had awarded to me at Crewe Show, Cheshire, on September 15th, 1883. One, a second prize of 15s., for best moveable hive complete, in Class 2; and one a second prize of 7s. 6d., for best cottage hive, in Class 3. I have not received the two prizes amounting to 11. 2s. 6d. I paid 2s. entrance-fee to Mr. W. E. Little, 1 Eastgate Row, Chester. I have got his acknowledgment for the same, and the prize-cards. I have written to the above gentleman in respect of my prize-money, but getting no reply, I have taken the liberty in asking your advice and assistance.—ERWIN CROWE.

A. H. Heath, Esq., Hon. Sec. of the Staffordshire Bee-keepers' Association, had not, on the 1st of July, 1884, received the first prize for the best exhibit of honey in sections which he obtained at the same show as the above. [We do not call this *good management*.]

#### PROPER NAMES OF THINGS.

Mr. Brown, page 191 *Bee Journal*, objects to 'proper names of things,' on the ground that 'Jones and Robinson' are too ignorant to understand the ordinary nomenclature of bee furniture. 'The terms sections and supers (the urns) are often more than the limited vocabulary of the labouring classes will sustain.' This is not very flattering to the intelligence of the English peasant, but is it 'fact'? Do not market-gardeners and florists of England know the hard names (Greek and Latin) of their flowers, indigenous and exotic? And do they not 'sput' them fluently? Mr. Brown declares that he will stick close to simple Saxon, but is he really not aware that in his very letter itself four words out of every line are of the Latin tongue? I must beg Mr. Brown's pardon for having misled him; I did not propose the names I suggested for general use. I stated clearly that I gave them only 'to explain our difficulties and my argument.' I requested the B. B. K. A. to fulfil that arduous duty for the advancement of the practical science of apiculture. If Mr. Brown is like Gallo, of course he will 'care for none of these things.' If we are to have *no names*, then we shall be fairly represented in *Punch* as follows:—

*She.* Who's my sister's partner vis-a-vis with the Star and Ribbon?

*He.* Oh! he—ar—he's Sir—Sir—dear me, I forget his name; but, you know, he went somewhere or other to look after that scientific feller—what was his name?—you know, who was lost or something, or else killed by some one!

Shake hands, Mr. Brown; we are both of us earnestly striving for the public weal, and it is no 'goak' to get *some pigs* over the stile.—FROGE, *Howtown, Ireland.*



## A REMINISCENCE OF A DAY AT MUCH HADHAM:

MISS GAYTON'S APIARY.

'I want you to do export's work for us at Much Hadham!' The voice was that of our friend Huckle. I knew what I was in for, but I would not submit without a protest. 'It's no use you trying to beguile me; you know I must be grinding away as usual; where is your army of certified experts?' 'They are all busy, and a day's holiday will do you good; you grind a vast deal too much, so I shan't take a refusal.' 'Much Hadham! It will take a day for me to get at it across country, besides I don't know how many times changing trains.' 'Nothing of the sort, you can get to Hertford by 10:30 a.m., and I will get ——— to drive you from there. It is a seven-mile's ride through the prettiest part of Herts; and besides you will see Miss Gayton's apiary, and hear how she manages to make a profit at such a season as this!' With such a pleader to contend with what could I say or do, so I accepted the inevitable, and agreed to go. Consequently, 10:30 a.m., Aug. 23, 1882, found me at the Hertford G.N.R. Station, and true to promise, my friend had sent an open cart to meet me; so away we rattled through the ancient borough of Hertford, and away to St. Margaret's, where we saw the Buntingford train, that passes through Hadham, start on its journey, as we crossed the New River. 'There goes the train, sir, but we shall be there first!' and my John was true to his word. The sun shone brightly, with just sufficient air to be enjoyable, and the roads were hard and dry; and on we rattled through Stanstead and Hunsdon at a merry pace. A glimpse here and there of groups of bar-frame hives and bee-houses told us something of what the Herts B.K.A. had done, and that we were in the county that had felt the influence of the Rev. H. R. Peck; but in the country itself we could find nothing special to account for a heavy honey crop. There are few fruit trees in comparison to many other parts we have visited; there was the usual average of meadow-land and ploughs, gentlemen's seats thickly studded on either side, and the whole scene, as far as eye could reach, was beautifully wooded and undulated. At last, two minutes before the train—we rattled up the long rambling street of which Much Hadham consists, past the church amidst the tall lime-trees, and stopped at the Rectory grounds. It was the annual show of the local Horticultural Society, and I need not trouble your readers with a description, beyond saying that it was splendidly organized under secretaryship of Mr. Gayton, brother to the lady who is so well known amongst bee-keepers. There were prizes for honey, one class for cottagers, and another an open class; and to that lady's credit be it said, she did not compete, but exhibited her splendid sections and nurseries with which she had carried off the honours at Kensington Show. Of course, the Bee-tent called for my undivided attention. It was well patronised, I remember, not only by bee-keepers, and the class of people who everywhere watch the expert with wondering eyes, but in a degree far too numerous to be agreeable to your humble servant, by *Apis* also of all classes and conditions. The season, Miss Gayton says in her published balance-sheet, was her worst. I certainly never met with anything like it but once in my experience. The tent was full of bees—Ligurian, Hybrid, and black. The bees in the skep defended their stores with vigour, and after the first time positively refused to be driven. They were strong in number and had ample stores, and 'halled' their queen, evidently in defence, times out of number. Not succeeding in driving, I 'threw' the bees *en masse* on to the table, and had a very lively time in liberating the queen from her loyal attendants, who persisted in 'halling' her repeatedly; and as sun-set approached, they clustered on my hat and various parts of my clothing by thousands, and when packing-up time at last

arrived, there were sufficient dead bees on the floor of the tent to fill a good skep. I have seen many cases of robbing, but this certainly eclipsed all others; and I have written this, holding as I do a very decided opinion about attempting to do justice to bee-keeping in a beehive late in the season, when there is no honey about, and plenty of marauding bees. But to pass on to a pleasanter part of my visit to Hadham. My idea of the conditions necessary to carry on a successful apiary received a rude shock when I had the pleasure of being shown into Miss Gayton's garden. Although that lady has always managed her bees, down to the smallest details, with her own hands, yet she has not succeeded in assuring her friends that they are 'perfectly harmless'; consequently, she has to be content with a small corner of the garden for her apiary, and there I found her hives packed so closely as to touch one another, to face three sides of a square, in, of course, the most out-of-the-way corner of the garden, so as to be the least amenable to any one. The difficulty of examining hives, the danger of inducing robbing, and the risk of losing virgin queens on their mating flights, I need scarce point out. I was assured there was not a pound of honey in the whole lot of hives, and all were being fed, and had been for some time previously. There was one curiosity amongst the lot, and that was an old worn-out, wingless queen allowed to live and roam with a young queen brooding at the same time. A heavy thunder shower sent us flying for shelter; and we left Much Hadham strongly convinced that successful bee-keeping did not so much depend on a particular district, or a large area of ground for an apiary, or even a fancy race of bees, as it did on diligent supervision, doing the right thing at the proper time, and always acting on that well-known, but much-violated, maxim amongst bee-keepers, 'Keeping all stocks strong.'

Whatever successes Miss Gayton may have in the future, and I wish her many; they cannot certainly be attributed to natural advantages. Much Hadham is not an *Eden* for bee-keepers, although it is often thought of with pleasure by AMATEUR ENTHUSIAST.

## Foreign.

GERMANY.

THE HEATH APIARISTS. No. III. THEIR HIVES.

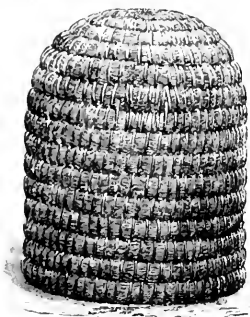

The above engraving shows a genuine hive such as is used by the Heath apiarists. It is of a cylindrical shape with an arched top. From top to the bottom the inside measure is 18 inches, and the diameter 11 inches. It is made of those fine ree-straws which are produced on the poor, sandy soil of the Heath, and bound with cane-strings. The wall of the hive is  $\frac{1}{2}$  to 2 inches thick, and is so strong that a man's weight will not bend it. The entrance is near the top of the hive, and no

Heath apiarist would put his bees in a hive with an entrance near or at the *bottom* of the hive. There are many reasons for having the entrance near the top of the hive. The Heath apiarist says: Foul and damp air passes easily out of the hive; the bees have no long way to traverse to store their honey loads away; they note every variation of the temperature much better; they never neglect a cleansing flight, and the queen will sooner find the entrance at swarming.

To support the combs, which run from front to rear, (that is, from the entrance to the back of the hive) the bee-keepers use nine sticks in three sets—those from the wood of wild roses are the best. The first three sticks run from the right hand to the left through the hive and cross the combs rectangularly 5 to 6 inches from the top; three others cross the combs somewhat in an acute angle; and the last set of sticks run as those of the first set, but five inches from the bottom. Two or three starters are fastened in the top of the hive, which run from the entrance to the back. Should it be necessary, the Heath apiarists fasten by means of three iron cramps under every hive one or two straw-rings. Filled with comb and honey, such a hive will weigh 60 to 80 lbs. The top of the hive has no hole or passage for the bees, as supers are not in use and have never been by the Heath apiarists.

The consumption of sealed honey or honey in combs has ever been very little in Germany. The prices of sealed honey are in Germany seldom higher than strained honey. Everyone wants strained honey, and does not care about paying for the wax, which he may not eat. This is a fact to take note of. The reader will now understand why every German hive, from that of the Heath apiarists to the Twin-hive of Dr. Dzierzon and other prominent bee-keepers of Germany, is not fit to place supers on. As no one cares for comb honey hives for supers are not made. The little that is needed in Germany one gets otherwise, and how this is done I shall tell the reader hereafter.

Since the time that the moveable-comb hive was invented, many efforts have been made to convince the Heath apiarists that it in many respects is better than their straw hives. This was not objected to by the Heath apiarists and therefore they have tried the Dzierzon twin-hive, the Berlepsch hive, and other box-hives with moveable comb hives, but they gave them up very soon. If you go from bee-yard to bee-yard in the Heath you never see one of these moveable box-hives. The only hive with moveable combs you will find is the Bogenstülper.

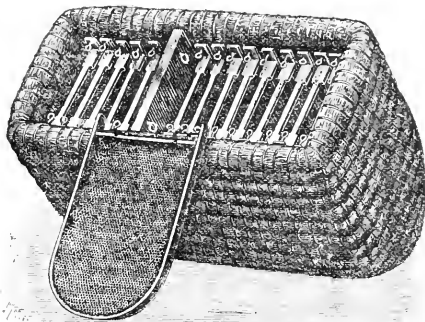

The Bogenstülper is nothing more than the old Lüneburger straw-hive, only it has moveable combs. It is made from straw with cane-strings a little larger, and not in the conical shape, but has an arched top as

the old straw-hive and like it must be turned over to get to the frames and honey.—C. J. H. GRAVENHORST.

## CHILI.

The exports of honey and wax from this country in 1882 have been as follows:—

HONEY, 1508 tons, 2 cwt. 1 qr. 14 lbs. viz.:—		Tons	cwt.	qr.	lb.
From Valparaiso	to Great Britain	637	6	0	24
.. Talcahuano	..	22	19	0	8
		660	5	1	4
.. Valparaiso	to France	115	19	0	21
.. Talcahuano	..	7	10	1	20
		123	9	2	13
.. Valparaiso	to Germany	692	11	1	1
.. Talcahuano	..	11	14	1	0
.. Coronel	..	0	1	3	7
.. Melipulli	..	12	6	1	23
		716	13	3	3
.. Valparaiso	to other Countries	3	11	1	16
.. Talcahuano	..	1	4	3	24
.. Coronel	..	2	17	1	10
		7	13	2	22

Wax, 68 tons, 1s cwt. 0 qr. 19 lbs. viz.:—

Wax, 68 tons, 1s cwt. 0 qr. 19 lbs. viz.:—		Tons	cwt.	qr.	lb.
From Valparaiso	to Great Britain	28	8	3	23
.. Valparaiso	to France	2	10	3	6
.. Copuimbo	..	1	0	2	6
.. Talcahuano	..	0	3	0	6
		3	14	1	18
.. Valparaiso	to Germany	34	1	3	5
.. Melipulli	..	1	4	1	15
		35	6	0	20
.. Valparaiso	to Ecuador	0	0	3	26
.. Valparaiso	to Peru	1	4	0	2
.. Melipulli	..	0	3	2	14
		1	7	2	16

The imports of honey into Chili during the same period amounted to 9775 litres, of which

Liquore	received	138	litres from Great Britain.
Copuimbo	..	116	..
Talcahuano	..	6866	Germany.
Valparaiso	..	2625	United States.
		9775	litres.

From the *Estadística Comercial de la República de Chile correspondiente al año de 1882.*

## SOUTHERN INDIA.

## RAIDING A WILD BEES-NEST.

Lazily devoting myself to the enjoyment of a comfortable arm-chair and mild cheroot after work one day in the verandah of a Southern Indian bungalow, my horse-boy disturbed my repose by announcing visitors, and forthwith introduced to my notice two small, black jungle-wallahs, or Kardabs, as they call themselves, who advanced with many salaams and proceeded to state their business.

\* We are indebted to the publishers of the *Practical Apiarist* and the *Deutsche Illustrierte Bienen Zeitung* for the use of the above engravings. See Advertisement.

It seemed they had discovered a large wild bees-nest in the forest some three miles away while out hunting bison, and proposed to take the honey that night before the moon was very high up: 'Would the Sahib whose presence was as grateful as a running stream to a thirsty traveller, care to come and see the work?' So the men explained their sudden appearance at my wigwam; and as this was a matter in which I had always felt much curiosity, the offer was promptly accepted. They were sent to chew betel-nut for a time on a log some distance from the hut, where their intidel, low-caste presence would not affect the high susceptibilities of my lowland butler, while I had some dinner and the unfailling tub—that real fountain of youth to the Anglo-Indian, whence, no matter how hard his day's work may have been, he ever rises rejuvenated. An hour after sunset found us ready to begin the march, and we set off in silence rapidly down a deep ravine, crossed the river at the bottom by a fallen tree, that made a dangerous and slippery bridge over the white foam glistening and rattling below it in the stony channel, and then struck up into the pathless forests beyond, through which we pushed for two miles with a rapidity that tried my walking powers considerably. Nor was I at all sorry when the Egyptian darkness broke, rolling away of its own accord as the moon came over the hills and sent its welcome beams percolating down between the tangled tropical vegetation over our heads and flooded with pale fairy light all the wide stretches of country round about. One momentary halt we had in this beatless scramble on a rocky opening in the woods. It was caused by my little chief, who brought us to a sudden standstill with a sign from his hand, and pointing to the long grass ahead, whispered the interesting information that a tiger had just crossed the road; indeed, the unmistakable roar of the big beast was very obvious, but, after a moment's pause, during which he sniffed the air like a hound on track, the savage nodded in a satisfied manner, and we continued our rapid march without encountering again any wild animals, though the Sambour deer were 'holling' all round, and a herd of elephants, washing themselves at a pool a quarter of a mile off, indulged in an occasional trumpeting that rolled through the stillness of the forest in a wonderful manner. A few minutes more, and a sparkle of fire comes between the tree-trunks, my guides taking a bee-line for it, which is all very well to their lithe and nimble bodies, but hard work for my less-accentuated limbs. Here we are, however, at last, and parting the fringe of low bushes, we enter a green amphitheatre, where a cheerful camp-fire burns in its midst, and half-a-dozen almost naked savages sit round the blaze. Two of them are women, one old and wrinkled, the other young and by no means devoid of grace to an eye used to black forms and faces. All the party jump to their feet as we approach, some of the men laying their hands on their spears for a moment, but soon reassured by the presence of my companions, though the women lit the spare ends of their 'saves,' holding them across their faces with woodland modesty for a time. Salutations and salutations having been done on both sides, and a few inquiries as to the health and well-being of each being duly made, I am taken to see the tree close by, dependent from a branch of which hangs the wild bees-nest discovered by the sharp eyes of the natives.

The tree is a splendid specimen of the *Ficus religiosa*, or sacred fig of India—a noble vegetable edifice, with a mighty stem, shooting far above its neighbours, which, indeed, it has dwarfed and stunted with the thick canopy of leaves that spreads out, cloudlike more than 100 feet overhead. But this is not my first bee-hunt, and the nest, a great dark mass, is soon seen hanging like a monstrous strange fruit near the extremity of one of the branches, the outline of which we can well trace against the sky. The question is obviously, how is it to be got

down? For this purpose my companions propose to send a man aloft whose business it will be to sever the branch, and let the whole mass fall to the ground. The way he is to climb the huge slippery trunk until he gets amongst the first branches, taxes both engineering skill and personal courage. A ladder has been constructed against the stem of the tree during the day; but surely it is the slightest and most flimsy structure to which a human body was ever intrusted. Suppose a tough bamboo of ten years' growth, split up into pieces six inches long by one inch broad, and each having a pointed end and a knobbed end, the latter formed by a part of the nodes, or hard rings, which occur at intervals in all plants of this order. These form the steps. With a supply of them in his waist-belt, a wooden mallet, and a tangle of rattan-fibre, the jungle man sets to work and forthwith drives into the tree a karandoo peg, at the height of his chin from the ground. On this he mounts, standing in some marvellous manner on the four or five inches which project from the tree stem, and when he has steadied himself, drives in again another peg at the height of his waist. These two are connected by a light and long stick, which is passed on to the worker, being lashed with split cane on each wooden nail just inside, the head left on purpose. In this way, peg after peg, the cool-headed savage builds himself up, step by step, and for the greater part of the time with nothing to hold to until the branches are reached, when the ladder is discontinued as becoming unnecessary, or is only carried forward in short lengths as required for unclimbable bits. The first part of his task now over, he descends to wait for a favourable night to form the bees' stronghold. Our friends are now however all ready preparing for the ascent, and we will watch them. A tree is first made almost under the nest up aloft, and as soon as it bears a great store of the leaves of the *Cassia*, *Albizia* and *Tabernaemontana* then, the immediate result being a column of pungent yellow smoke circling all among the leaves, blotting out some dozens of stars in the beautifully-pangled heavens, and considerably disgusting the creeping insects, who begin to hum in angry manner, plainly audible from where we stand. Mats of palm-leave are at once spread directly under the aerial hive, and all is ready. The Kadaris are then assembled in a circle round the man who is to get up to the nest, and he quickly divests himself of everything but the smallest of rags round his hips, receiving a small sharpax from one of the gang. I, standing a little way back, notice that before commencing this ingenious business he takes a large basin of water, and after a tentatively letting some fall to the ground, drinks up the remainder. 'To whom could he spill that water?' I ask the chief near me, and the dusky barbarian replies, 'To the souls of the good men round us in the darkness, Sahib.'

And now the climber moves down to the tree, and, casting his eyes aloft for a moment, gets his toes on the first round and is up as high as our heads. Another big step during which the slender pegs creak dreadfully, and we can see little but the soles of his feet. The man and he is out of sight in the shadows, alone in his perilous journey. His face close pressed to the green bark, that gives no finger-hold and his feet on the contemptible 'clothes-pegs.' A slip, or a gust of wind, and we shall hear the creak of the ladder and the terrible thud on the hard ground that too often ends these strange exploits. But it is not to be so tonight, and the 'good folk' in whom he has so much trust guide his feet to each slender projection. In a minute or two a low 'Hu! hu!' comes from the leafy mazes above us, and our friend is safely among the branches. 'Put the fire out,' whispers my guide, and the camp-fire is immediately scattered, the hot embers being trodden out by the leather-hard soles of the men. The sudden quenching of the flame relieves our eyes, and now we can look up into the lovely moonlight that makes the leaves look like black mosaic overhead. There goes the sharply outlined savage on

hands and knees down the branch whence hangs the nest, looking for all the world like an overgrown 'coon.' All eyes are bent on him, and in a little time comes the twinkle of his axe in the starlight and the rustle of the falling chips on the leaves of the low growing shrubs. He works with a will for a minute or so, then crouches low, and with a sharp snap the forward part of the branch sags down and breaks off. There is a loud sound of breaking twigs followed by a heavy thump on the hard soil, and the deed is done.

It is now, however, a matter of life and death to keep still, for the bees are swarming out to revenge the ruin of their home. For this reason the camp-fire had been destroyed that they might not see its glare and fly to it, and we sit silent for a space until the whole brood is out and after making an angry but fruitless search, have clustered up aloft where they will stay until to-morrow's sun sends them to seek a new location. Then the fire is kindled again; the hero of the evening joins us from his ladder safe and sound, and we go in a body to examine the nest, a beautiful structure but little hurt by its fall, containing, perhaps, five pounds of honey as fragrant and delicious as that which brightened the eyes of Absalom, besides two of wax—a royal prize! Two or three such 'hauls' in the short bee-season will set up the whole family of our courteous little chief and bring him in, moreover, enough rapeseeds to get his women fresh bangles all round.—*The Globe.*

## Echoes from the Hives.

*Abingdon, Berks.* The weather is still capital for the bees. My bees are still working most wonderfully well, from six in the morning till eight at night; and this evening they are busy in killing the drones. By using my improved glass supers, I have taken fifty pounds of clear white sealed honey from one straw skep, which I bought in a village on Easter Monday at Grove near Wantage, and now leaving a super on with seventeen pounds of honey at present for winter. I shall be pleased to inform any one how to work these supers. I have another straw skep, and have taken forty-six pounds by these supers, leaving one super on with ten pounds in at present for winter. The first super was taken off May 26th; the last on each hive was taken off on June 28th.—*D. BRICKLAND.*

*Grantham, Lincolnshire.*—Bees appear to Value Good Quarters.—On Saturday last at 10 a.m. I examined a stock (foreigners) in a Huber leaf hive, found it crowded with bees, brood even on both end leaves next to glass, saw the queen, closed all up, put on super. On visiting the hive later in the day, noticed bees quiet, removed super, opened my book, found it half blank, and no queen in it, searched my garden for the swarm, inquired of my neighbour, but without success, so concluded I had lost it. Mid-day on Sunday, seeing extra bustle about the hive, I was tempted to examine it to see the cause, found it again crowded, and the queen quietly walking over the outside comb. The runaways had a trip, a night out, and, as appears, failed in finding a better home than their old one, returned, and have quietly set to work again. Bees are doing well in Lincolnshire. I have made several visits, and to different quarters, and find stocks strong and honey being freely stored.—*R. R. GORDERY, June 25th.*

*Hereford, July 3rd.*—The honey harvest is the best we have had for years, the weather during June (after the first week) being dry and warm. We have had copious thunder-showers during the last few days, and the early cut hay-fields are already sprinkled with white-clover. Lime-trees (which were a failure as regards bloom last year) are loaded with buds, and everything promises well for a grand total of honey. Even weak stocks are gathering honey, and swarms hived on

foundation are working in sections. I have taken up to date forty-four 1-lb. sections from one hive, which has now swarmed out; my best colony run for extracting has given much more, but I have not yet weighed it.—*A. WATKINS.*

*Devonshire, 8th July.*—We are indeed having a grand bee season; the weather during June has been everything that could have been desired, and honey is being gathered in large quantities. It is the best season that has been known for the past ten years; this will be a wonderful stimulus to apiculture, as, when we have had so many bad seasons in succession, a great many have given up the pursuit in disgust. The total rainfall for June was 2.97 cents, most in twenty-four hours, 1.40 cents, on the 28th. Number of wet days seven; the total fall for the corresponding month in 1883 was 2.60 cents, but then there were sixteen wet days. There still appears to be some difference in the law relating to bees. About a month ago a cottager applied to me for advice on the following:—his bees swarmed, they were duly hived, but in the afternoon left the skep and flew some distance to a neighbour's garden, and the owner watched them take possession of a tenantless hive with empty combs, the neighbour refusing to give them up. He also stated that this man had six more hives with combs as decoys in his garden, and wanted to know if this was legal. A very different case occurred in the parish of London. A labourer had a swarm; he hived them, placed them on their stand, and all went well for three days, when a swarm from some distance belonging to another bee-keeper flew straight to his apiary, and united themselves to the above-named swarm; so I asked him what he intended doing? 'Oh, sir,' he replied, 'we can't well separate them, but at the end of the season we shall divide the honey.' Here is an instance of true honesty. In another case, where a swarm took possession of an empty hive, the owner was paid for his bees.—*WM. N. G., Hon. Sec. D. & L. B. K. I.*

*North Leicestershire.*—Dry weather prevailed, on the whole, for a month prior to 7th inst.; on the 8th and 9th thunder-storms were frequent, and the bees unable to work so vigorously as in the dry weather. White clover is in full bloom, and the bees are filling supers, bars, and sections at a rapid rate; and unless cold weather sets in, the yield of honey will be enormous.—*E. B.*

*South Cornwall, July 10th.*—The last echo repeats itself. *Tas mibi . . . iterare mella.* Honey has continued to pour in for a month. The heavy showers of Saturday and Sunday last caused but little intermission, as I know from the extraordinary work done in a skep from the latter-mentioned day to last Tuesday, when I drove a swarm to a better habitation. Sections have to be promptly taken off when full, and replaced by empty ones, that the willing workers crowded at the door may come in. Accounts from all round are favourable. Such quantities of clover-honey have not been gathered for years, and now, after the grateful showers, there is a fresh growth on the meadows, and the air is filled with a delicious fragrance.—*C. R. S.*

*Bray, Ireland.*—From the middle of June till 5th of this month the weather has been almost perfect for bees, hardly any rain falling during that time; and some hives have already given 50 lbs. in 1-lb. sections, and a swarm besides, though other parts of the country have not been so fortunate.—*E. D'O., JUN.*

## Queries and Replies.

*QUERY No. 7-5.—1. Uniting.*—Would Mr. Hewitt kindly add to the many lights he has thrown on apiculture by an explanation?

He says, p. 225, 'a better plan would be . . . to unite bees and combs to another strong stock.'

Is it to be carried out by 'doubling,' on the Stewarton

principle, or how? If they swarm (in a fortnight) ought we to return that swarm or hive it separately in lieu of the strong stock we have thus united and (theoretically) lost?

2. *Smoking Bees.*—Would it be too much to ask Mr. Hewitt to tell us what operations can be safely ventured *without* using smoke? I commenced without a smoker, using sweets in the form of spray (and by-the-by Dr. A. Clarke's double handball spray-producer is far the better one, it sends out a fine continuous shower). I found I could do anything with my bees without veils or gloves, with sugar and gentleness. Now alas! I find my friends a little irritable, and I have very reluctantly 'to eat them.' I am sure many use smoke to an unpardonable extent, and hence my query is one of mercy and of general interest.—*URIGER, Horseback Rectory, Ireland.*

[1st. It depends on circumstances, kind of hive, whether comb or extracted honey is required, &c.; the end being to unite both bees and brood of two stocks into one. If to be worked for comb honey, I would remove all combs which had no brood, and extract all the honey. If worth extracting—from the brood-combs, and pile sections above; if they swarm (which they might), I would hive them on the old stand, giving them all the bees, on eight frames of empty combs or foundation, and replace sections above. It is well known bees work at their best under the swarming impulse; the brood-combs I would distribute amongst other stocks. If worked for extracted honey, then I should give them all the combs; and if they are well extracted from and the heads shayed off any drone brood which may appear, and all queen-cells caps removed as they are formed, they won't swarm.

2nd. It would be too much of a pile to catch one all the operations that can be safely ventured *without* using smoke; therefore I will briefly as possible give what I think is wanted. Bees vary much in temper; the worst-tempered bees I ever saw were some blacks, the result of crossing bees from different parts of the country. The only way in which I was able to handle them was to put an empty hive and some old combs after dark on their stand, and remove them away in some quiet corner; the next day the old bees—which do the 'sticking' business—would have left it and gone to the old stand, when I was able to examine it towards evening, mostly without smoke, after which it went on the old stand again. As a rule, most black bees may be safely handled without smoke, when they have no sealed honey, on a warm day, and when they are not queenless, using only gentleness. Their tamest state is when they are stinging syrup in empty combs and no brood in the hive, and their most savage state when queenless with sealed honey and brood with queen-cells maturing. Syrian bees, on the contrary, are always tame, and never require anything but gentleness.

The smoker I now use is the old tin fumigator, filled with cotton rags or waste. When dis-jointed it keeps afloat for hours; I have only to turn up the quilt and blow in a puff or two to quiet them. A 'Roof' smoker always failed to quiet one stock I had, while this one always succeeded.

I have never made much out by spraying with syrup, except sticking bees together and inviting robbing; therefore 'spraying' never found favour with me, and I can say nothing about it one way or another.—*JOHN HEWITT.*

QUERY No. 786. (M. H.).—1. *Driving Bees.* I have a second swarm of bees in a straw hive. I wish to drive them into a bar-frame when the honey season is over. If I extract all the honey from the straw hive, and give them the empty comb, fastened into the bar-frame, will they work it up before the winter, my feeding them up for the winter?—*A.* You will find the combs of a second swarm very tender to extract from and tie into frames when you drive and transfer, but with care

you can do it. Put slips of wood along the bottom of the combs to receive the tapes, and prevent them from cutting into the combs. When the combs have been fixed by the bees you may feed them up for the winter.

2. *Reducing Bar-frames for Winter.*—When reducing my bar-framed hives for the winter, if there is any brood on the combs that come out, what am I to do with it? or is brood all gone at that time?—*A.* When you reduce the size of the hive for winter, by removing outside combs, you will find very little brood, and that quite in the centre. Do not disturb it. 3. *Queens with Second Swarms.*—Do two queens take off a second swarm, or only one?—*A.* It often happens that two or more queens leave the hive with second swarms, sometimes forming one cluster, and sometimes several small ones, each with a queen. 4. *Packing Bees.*—Next March I wish to move three bar-frame hives, probably by train, some distance. Would it be a good plan, when putting up the hives for winter, to tie in each comb into the frame with wire? or how can I fasten them in to keep them from breaking? In the beginning of March it would be too cold to take out each comb, so I thought if I could arrange it before it would be better.—*A.* We should not advise putting wire into the hive before winter, as the bees will worry at it, and wear themselves out. You can move bees in March with little chance of breaking the combs, which are then not so tender as in hot weather. Fix the frames so that they do not swing, remove the quilt, and put a sheet of perforated zinc or canvas over the frames, put cushions of hay under the floor-board, and send the roofs separately. Put handles of rope to lift by, and generally make the package as easy and convenient for the porters to handle as possible.

QUERY No. 787. (A. D. P. D.).—*Bees Clustering.* Would you kindly let me hear what you think is the cause and remedy for the following? I have a stock in a straw skep, which, at the commencement of June, showed signs of swarming, the bees clustering round the entrance to the hive, and occasionally hanging. About a fortnight afterwards they appear to have all got inside the hive—there being no signs but an extra number of bees being about the entrance. They could not have swarmed, as they were carefully watched. Within two days they were hanging again as usual, but last Sunday they all disappeared again, but there were many more bees about the entrance than there are after swarming. On Sunday night, however, they recommenced to hang, and on Monday they were hanging just the same as they were at the commencement of June. What course should I pursue? I note there are a good many drones about.—*A.* Your bees have been changing their queen. The variation in temperature would account for the alternate clustering outside and peering within the hive. On the old queen being superseded, there would be a period of three weeks, or thereabouts, before the young queen began to lay, and the population would be reduced. The drones are necessities in this case. You can do nothing. If in a frame-hive you might have extracted the outside combs.

QUERY No. 788. (A. P. O.).—*Absence of Pubescence. Defective Wings.* I observe that a writer in the *Irish Farmer's Gazette* says, 'If any bees are observed being ejected from the hive of a glazy appearance, through the pubescence being worn off, do not brood from such hives.' What does this mean? I notice in one of my nuclei a number of bees with the abdomen quite black and without bands, and others with defective smaller wings, which cause a peculiar rattle when in motion. Can you tell me the cause of these anomalies, or say where would be the danger in brooding from them when one gives them a queen-cell from other stocks?—*A.* By the *pubescence* is meant the downy substance on the thorax and abdomen of the young bees.

The entire absence of this causes a bright glossy appearance, and is a mark of disease, the origin of which is, at present, uncertain. It has been discussed in the American bee journals repeatedly, and various opinions respecting its cause have been offered. There is no doubt that it arises from an imperfect development of the bees when in the pupa or nymph stage, but whether it is hereditary or springs from local causes is uncertain. Our own opinion is that it is often caused by want of ventilation. It invariably shows itself in the summer months, and we have never witnessed a case where the entrance has been open the whole width of the hive. During very hot weather our hives are slightly raised, all round the floor-board, sufficiently to allow of a current of air passing beneath them, but not of the exit of the bees. The defective wings, &c., of which you speak are probably caused by the too great lowering of the temperature when the nuclei were formed. There can be no objection to a queen-cell from a healthy stock, provided sufficient heat be kept up in the nucleus. 2. *Liberating Queen*.—In above-mentioned nucleus which had a queen-cell capped over, I looked on the eighth day after to see if the queen was hatched, but found the queen all torn open at the side, and nothing in it but a piece of royal jelly. From this I inferred that the queen had failed to hatch, and that the workers had torn the cell open at the side. Next day, however, I found a healthy young queen in the nucleus. As this proceeding is contrary to what I read in books on apiculture, can you give any cause for the queen hatching in such an unusual manner? I cannot understand it, and would suppose that it might result from an adjoining comb being pressed closely to the mouth of the royal habitation. In such a case would the bees liberate the queen at the side? In above case, though I believe there was no such pressure. —A. Yes, the bees would liberate the queen in the case you suppose, but are you quite certain that the nucleus had not two queen-cells, and that one queen, having hatched, was not allowed to destroy the other cell? 3. *Fertile Worker*.—In another nucleus only a week formed (or rather removed from top of a strong stock) a queen-cell has been formed from eggs which I gave it, and a number of eggs are laid in several adjoining cells, as many as seven in one cell. Is this the doing of a fertile worker? —A. No doubt you have here fertile workers, which are the great bane of the nucleus system. 4. *Excluder-zinc*.—Would you recommend me to use excluder-zinc between frames and super? Should I use an adapting-board with slits cut for passage of bees? —A. No. We never use excluder zinc between hive and sections, and we never have brood in our sections, nor pollen either. We use no adapting-board, but a simple frame for holding together the sections and allowing  $\frac{1}{4}$ -inch spaces between the frames and sections. 5. *Supercing*.—My bees are working in section frames and supers, but much better in the latter. After supering, would it be injurious to remove the section frame altogether? —A. We should advise you to allow the section frame to remain. 6. *Number of Frames*.—With twenty-nine sections on super, how many frames for brood would you recommend? —A. Ten Standard frames. Say eight for brood, and the two outside ones for honey and pollen; but the size of the hive should depend on the fecundity of the queen.

#### NOTICES TO CORRESPONDENTS & INQUIRERS

G. W. HANSON.—We are sorry to say foul-brood exists in both samples of comb sent, but worse in No. 1.

A. LOVER OF BEES, *Goldstone*.—*Condenned Bees*.—The less work you give them to do the better. If you can get six or eight combs, according to whether you unite three or four lots, stored by other bees and give them to your condemned ones with just two frames foundation to work out, you will find it a good plan. If, however, you cannot manage this give six or eight

sheets foundation, and 28 lbs. sugar made into about 35 lbs. syrup. Four lots would not require more stores than three; and would be found in spring to have consumed less.

LINCOLNSHIRE BELL.—1. *Transferring from Skeps*.—Do not, on any account, use puff-ball. Driving is by far the best plan. If the honey harvest is not over in your locality by the time you read this, we should advise you to withdraw the central plug, which you can do by a screwing motion, and any damage to combs will soon be made good by the bees; this will allow the fillers to go inside. At the same time put on a cap, or better still, a board with some sections. When you have got all the honey you can in supers, drive the bees—never mind if a comb does break, as they must all be cut out when the bees are driven. Tie all the centre combs of the skep into your frames with tapes. The outside ones being store combs, are not to be transferred. The combs will contain sufficient pollen. Pea-flour is only needed in spring-time. Put your sheets of foundation between the old combs, but not for a few days until some of the brood has hatched out. 2. *Bar-frames fixed*.—You should have left no space between the crown-board and the frames, and if you put a piece of ticking between the two you will find no fixing takes place. If the combs are built irregularly in the frames, lift the whole lot out by passing slips of wood under the frame-ends, cut all the combs out, brushing the bees off them into the hive, then proceed to flatten them and tie into the frames. Finally, return to the bees to refix. 3. *Putting on Sections*.—Yes, you did quite right. The lid on your section-box was correct as serving to retain the heat.

T. T.—(1) *Rhododendrons*.—We have heard it said that honey collected from rhododendrons is poisonous; but our bees are constantly at work on them, and we have noticed no ill effects. The flowers are not in sufficient numbers in this climate to cause any fear. (2) *Boiling Honey*.—Boiling prevents granulation, but spoils the honey by removing all the fine aroma and the flavour of the flowers from which it was gathered. Extracted honey will keep in its natural state for years if hermetically sealed in glass or other jars, but will always granulate. If the honey is properly ripened in the hive before extraction—that is to say, if all the cells are sealed over—there will be no fermentation afterwards if carefully preserved.

ROBERT CUNNINGHAM, *Blairadam*.—*Decey Bees*.—It is not an honourable proceeding for any one to use a hive with combs as a decey for swarms. We do not think you can substantiate your claim to the swarm, as the law of bees requires that you should not lose sight of them from the time they emerged from the hive until they have settled. If not kept in sight, the bees become the property of the first person who secures them. No man can swear to bees; with lost identification the property ceases and becomes in common.

ENQUIRER.—The piece of comb sent arrived with very active fermentation in progress in its saccharine matter. The grubs were very carefully examined, microscopically, and no trace of foul brood germ discovered. This may be regarded as perfectly conclusive, as any foul brood contamination would at once be apparent. It will be interesting to watch the course of events, as some unhealthy conditions are certainly present. —F. CHESHIRE.

T. S., *Kentish Town*.—The comb is, unfortunately, full of foul brood germs. One cell alone must have contained several hundred millions of them. You should take such steps as may be within your knowledge at once. —F. CHESHIRE.

ASCOT.—*Number of Frames in Hive*.—Had you given your swarms, when they had filled six frames, two or three more, they would have had a larger population

to work in the supers. Unless you have a harvest of heather to follow, or unless you want some more combs to give to driven bees, you would do well to leave well alone, as the main harvest will be getting over by the time this reaches you.

R. H. COWELL.—*Queens Piping*.—Queens do not always pipe. The cry you heard was probably the challenge of the first hatched to another about to hatch, which has, no doubt, been destroyed by now.

J. P. B., *Skiliberca*.—The difficulties you have had to contend with are those which must be encountered by a beginner in bee-keeping. In time the stings will not have such an injurious effect, and to some degree you will be what is styled 'inoculated.' It is not desirable to smoke your bees too much or too frequently. Gentleness and tact will soon enable you to overcome the initiatory obstacles.

WILLIAM PEARS.—1. Had you increased the number of frames from eight to ten before the honey harvest it would have been well, as you would have an increased number of bees at work in sections; but we would not advise you now to interfere with them. 2. With a little care in packing, there need not be any appreciable loss in the number of bees in removing them to the heather, and we may safely predicate that the increased honey harvest will be ample compensation for any possible loss. 3. The B. B. K. A. are about to take active steps for the formation of County Associations in the northern Counties.

ST. GEORGE.—1. *Queenless Bees*.—The second lot were queenless. Bees with out a queen will not leave the skep freely. 2. *Transferring*.—Most likely, in transferring, you destroyed the queen-cells on which the bees were depending, and having no further means of raising a queen, they deserted the hive. 3. *Removing Bees*.—If the bees in the cottage-roof possess a queen which is almost certain to be the case, the whole may be transferred successfully, but the operation will be difficult. It will be necessary to remove them to a distance—say two miles.

ST. ANDREW.—Please find replies in 'Useful Hints.'

R. FORD.—*Storing Honey in Sections*. At this time of the year, if the honey-cells were uncappped and placed behind a division board, empty sections being placed above, it is probable that the bees would store the honey in the sections, but we have no experience of this mode of proceeding.

B. W.—1. *Cutting*.—No. The driven bees would all be killed, instantly. If you wish to unite successfully, the one lot must be dispossessed of their combs—in a skep, driven out—and then united with the driven lot, and shaken out together on a sheet in front of the hive they are to occupy, when all will run in quietly together, and no fighting will take place. It is well, however, to take away one of the queens. 2. *Humble Bees*.—Yes; humble bees do sting. We know this from experience. 3. *Proportion of Bees out at Mid-day*.—All, except the young bees of a day or two old, and a few nurse bees, and perhaps drones.

W. J. JONES. The comb forwarded exhibited chilled brood, and foul brood in an incipient state. Consult, without delay 'Useful Hints' in last number, and act upon the teachings there contained.

J. C. NODDER.—The bees forwarded bear evidence that their death was caused by suffocation.

AN ANXIOUS ONE. The bees, feeling a sense of insecurity in the combs, have joined them together. The combs being the proper distance apart, may by a little trouble and attention be straightened when they become more toughened.

MR. GORREY, *Granttham*, having a queenless skep, thrice offered the bees queen-cells, and on each occasion the queen-cell was destroyed. Subsequently they at once

accepted a strange queen. He desires to know the reason of the bees rejecting the queen-cells.

DEVONIA.—1. *Transferring*.—You should give all the combs from the skep to the bees, except such as consist of drone-cells. It is as well to extract all the honey to reduce the weight of the combs.—2. *Ligurianising*.—Now is the best time, not only are the queens cheaper than in the spring, but by that time you will have all Ligurians, the blacks having died and been replaced by the progeny of the foreign queen. The difference in appearance is so marked that no one who had never seen a Ligurian could be mistaken.

B.—1. *Sections partly filled*.—If the honey flow ceases before they are sealed, they are perfectly fit for use. 2. *Unsealed Honey*. The unsealed honey will keep until the heather opens, and you may get them finished. It is not well to mix two kinds of honey, but if that is your only chance of getting them finished it is advisable. 3. *Sealed Sections*.—A section perfectly sealed to the wood on all sides is comparatively rare; there are generally a few cells round the sides unsealed. Other things being equal, the more perfectly sealed sections will take prizes before those less perfect. 4. *Feeding Extracted Honey*. You may give it in any kind of feeder placed behind the division-board with access to it underneath for the bees. Honey in uncappped combs placed in the same position will, being outside the hive proper, be treated by the bees as a plug, and removed to the hive or supers. It is a very good plan to adopt when no extractor is at hand. 5. *Casts*. You cannot well prevent casts issuing, and can only return them again and again until all the young queens save one are destroyed; but your plan of uniting several casts into one skep is a good one, when you are so fortunate as to have so many at once. If each of your casts weighed 3 lbs. they were large ones, and a hive stocked with three such casts should be a splendid one.

## E. M. HART & CO.,

The LONGSTOCK HIVE Manufactory,  
SPOCKBRIDGE, HANTS.

### SPECIALITIES:

HIVES, complete, from 6s. SECTIONS, V cut, in 6 sizes.  
FOUNDATION, Flat, or natural based.

CLARK'S COLD BLAST SMOKER. 'Far and away the best Smoker.' 3s., post free.

HART'S SIMPLEX FEEDERS. 'The easiest and best to use in any way.' 1s. 6d. each, 15s. per dozen.

THE 'SWANMORE' SECTION CRATE. 'The most perfect Crate made.' (60)

The Trade supplied. Price List on application.

## CHARLES T. OVERTON,

First Class Exporting & Super Bee-keepers' Association.

## THREE BRIDGES, SUSSEX,

Bees to call attention of all Bee-keepers to his

NEW STOCK OF BEE-KEEPING APPLIANCES for 1884,  
and hopes to be favoured with their support.

*Silver and Bronze Medals, and other Prizes, awarded at Beekeepers', Knightbridge, Hants, and other Shows, for the Best Bee Hives, Bees, Smokers, Sippers, Extractors, Comb Foundation, &c.*

Orders can now be booked for Prime Stocks, and Swarms, of ENGLISH, LIGURIAN and other Foreign BEES, for early spring delivery; also Imported LIGURIAN QUEENS.

### SPECIALITIES.

The 'COWAN HIVE' and Extractors. Bingham Smokers, the best in use; Supers; Honey Backs; Comb Foundation, American 2-lb. and 1-lb. Sections. FLAT TOP STRAW HIVES, with hole in top for feeding and supering, 2s. each; Grates of 18 1-lb. Sections for Straw Hives, 6s. each, complete.

Questions on Bees and their Management answered by return of post, 3d. stamps. Send 2d. for *Modern Bee-Keeping*, 1s. 5d. for *Cowan's British Bee-keepers' Guide*. Catalogue free on application.

**DR. PINE'S**

**Registered Removable Metal Frame Ends.**

*Price Medal, B.B.K.A., 1882; and numerous other Prizes.*

BY the use of this valuable invention the making of Frames is simplified. No metal runners are required, all systems of frames are rendered interchangeable, and propolisation is reduced to a minimum.

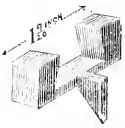

Unfortunately, as is the case with all inventions of merit, numerous substitutes are being introduced under the name of 'improvements.' But there is not one of these so-called 'improvements' which does not possess defects from which the original invention is free.

It is, therefore, absolutely necessary when ordering Hives to specify that the Frames are to be fitted with 'DR. PINE'S ENDS,' and with no others. All Hive-makers will supply Hives fitted with them, and generally without extra charge, the small cost being saved in diminished cost of labour.

Price of the Ends, 1s. per doz. or 10s. per gross.

**DR. PINE'S Woven Wire Veils.**

*Price Medal, B.B.K.A., 1879.*

Do not confine the breath, do not obstruct the sight, and cannot be blown against the face or ears.

Price 2s. 6d. each.



**DR. PINE'S BEE-KEEPERS' LOTION**

Is the acknowledged Remedy for Stings, especially for removing the subsequent inflammation. Price 1s. 6d. per bottle.

*The above Inventions may be obtained from*

Messrs. NEIGHBOUR & SONS, Regent St. & Holborn, London; And from all respectable Dealers in Bee-keepers' Requisites.

*Dealers may obtain Wholesale Prices from the Inventor, Mr. F. LYON, 94 Harleyford Road, London, S.E.*

**BEE VEILS.** Improved with Wire Gauze Fronts, or with Silk Brussels Net. Post free 1s Stamps. Address B. DIXON, Papworth-Everard, St. Ives, Hants. (59)

**CANE (PREPARED)** for making Straw Skeps. 11b. postal packages—Fine, 2s. 3d.; Coarse, 1s. 3d.—free. SALICYLIC ACID, 1s. per oz. post free. THYMOL, 1s. packets free. Either of the foregoing cheaper in quantity. Address J. R. W. HOLE, Tarrington, Ledbury.

**THOMAS B. BLOW,**  
WELWYN, HERTS,

Manufacturer of Bee-keeping Appliances of every Description,  
And IMPORTER OF FOREIGN BEES,

BEGS to call attention to the unrivalled quality of his productions. By the aid of special power machinery he is enabled to combine moderate prices with high quality. Mere lowness of price is not so much aimed at as accurate fit and finish, all goods being adapted both for the convenience of the Bees and ease of manipulation to the Bee-keeper.

ILLUSTRATED CATALOGUE, 48 Pages, 50 Illustrations, full of interesting and useful information, Free on application.

**THE HEREFORDSHIRE SCHOOL OF APICULTURE**

SUPPLY BEES, HIVES, and everything pertaining to Modern Bee-culture. Hives made only of the best well-seasoned wood, a quantity of which is always kept ready cut and prepared for putting together.

Awarded *Honourable Mention* for a Hive exhibited at COBE INDUSTRIAL EXHIBITION, 1883, and *First Prizes* at various County Shows. Revised Catalogue for 1884.

**J. R. W. HOLE,**  
*(Expert to the Herefordshire B. K. A., qualified by B. B. K. A. Certificate.)*

Address—TARRINGTON, LEDBURY.

**H. G. PARKER,**  
WATCHMAKER & JEWELLER,  
ALTRINCHAM, KNUTSFORD, and  
WARRINGTON.

All kinds of Bees, Bee-Hives, & Appliances,

*For Old-fashioned as well as Modern Bee-keeping.*

BAR-FRAME HIVES from 4/6 each, COMB FOUNDATION, SMOKERS, FEEDERS, &c., at most reasonable prices.

Winner of 15 Prizes & Medals for Bees & Appliances last year.

- 1st Prize for English Bees, both in 1882 and 1883.
- 1st Prize for Observatory Hive.
- 1st Prize for Best and Cheapest Cottagers' Hive, on the Moveable Comb principle, not exceeding 15/.
- 1st Prize and Silver Medal for Best and largest Collection of Bee-Hives and Appliances for Modern Bee-keeping, including a Hive complete on the Modern System at 25/-, at the Cheshire County Bee-keepers' Association Show; also 1st Prize for Largest Collection in 1882.
- 'MODERN BEE-KEEPING,' the Simplest and Cheapest Book. Price 6d.

Cash with Order to be sent to Altrincham. (61)

**WILTS BEE-KEEPERS' ASSOCIATION.**

THE COUNTY SHOW and HONEY FAIR will be held at WESTBURY on August 13th, 1884, in LEIGHTON PARK, in connexion with the KEEVIL DISTRICT HORTICULTURAL SOCIETY.

ENTRIES CLOSE ON JULY 31st.

At the same time an EXAMINATION will be held by the B. B. K. A. for THIRD-CLASS EXPERTS' CERTIFICATES. Candidates must send their names to the Hon. Secretary on or before July 12th.

Prize Lists, Entry Forms, &c., to be had of the Hon. Secretary, REV. W. E. BURKITT, BUTTERMERE RECTORY, HUNGERFORD.



# THE BRITISH BEE JOURNAL

Communications to the Editor to be addressed 'STRANGEWAYS' PRINTING OFFICE, Tower Street, St. Martin's Lane, w.c.'

[No. 151. VOL. XII.]

AUGUST 1, 1884.

[PUBLISHED FORTNIGHTLY.]

## Editorial, Notices, &c.

### BEWARE OF FALSE PROPHETS.

We have heard a *good deal* lately of the Mahdi, who has stirred up so much strife in those provinces of Egypt known under the name of the Soudan. A Mahdi has risen up in our bee-keeping world, and is equally busy in sowing the seeds of strife and dissension amongst us. Our false prophet, however, is not like the Veiled Prophet of Khorassan in Moore's poem, who kept his face so carefully covered that none could see its hideous aspect. The Liverpool Mahdi is far too much pleased with himself either to *hide* his face under a veil, or his light under a bushel. The veil, which for decency's sake he feels obliged to cast over his schemes, is so thin that any one who is conversant with the history of British bee-keeping can easily see through it. As some of our readers, however, are not conversant with this history, we will lift up the veil which covers the designs of the False Prophet of Liverpool, and let them know what has produced the attacks on the British Bee-keepers' Association, and the accusations of mismanagement brought against Mr. Huckle in the *Beekeepers' Record*, the organ of our apian Mahdi.

They are merely the impotent ravings of disappointed ambition. The Liverpool Mahdi has attempted to found a large Association, which should take the place of the British Bee-keepers' Association in the North-west of England, and he has found the old Association too strong for him. 'Talk of a fellow like that upsetting the British,' said an old bee-keeper. 'Why, it's like a cock-sparrow pecking at the Rock of Gibraltar!' The Lancashire and Cheshire Association was started from the first in direct antagonism to the parent Association. 'Defiance' was its motto from the very outset. The present Secretary of the British Association attended one of their early meetings, and pointed out to the Liverpooldians that the county of Lancashire would give them quite sufficient to do if they worked it properly; but they would not listen to him. Now when the counties adjacent to Lancashire are beginning to assert themselves, when Cumberland, Yorkshire, Cheshire, Flintshire, and Denbighshire, are founding Associations of their own, when the Mahdi of the North-west sees his empire becoming small by degrees and beauti-

fully less, his disappointment cannot contain itself, but finds a vent in invectives and railings. He denounces the British; he denounces the County Associations as vehicles for the spread of bee-keeping,—they are no better in his sight than '*our horse shays*.' His ravings culminate at last in a wild, despairing cry of '*L'Union fait la force!*' or, as he kindly translates, like Punch's butler, in compassion for the ignorance of his readers, '*United we stand.*'

Now this is the very last thing that the Liverpool Mahdi wishes to see. The sight of bee-keepers standing united together is an eyesore to him. Foiled in his attempt to supplant the British Bee-keepers' Association by a North-western Confederation, he is now seeking to disintegrate the system on which the Central Association is founded, and to destroy the relationship existing so harmoniously between parent and her children.

All bee-keepers should be on their guard against this False Prophet. From the correspondence which Mr. Huckle has published in this *Journal*, it will be seen that the statements which he publishes are made without any regard to facts, without any attempt even to ascertain whether the statements are true, before they are published to the world. We must go even further. Some statements are made which the editor of the *Record* knows to be untrue. Such a statement is that the Committee of the British Association are practically self-elected. Mr. Huckle has called upon the editor of the *Record* to verify his statement that the Annual Exhibitions of the B. B. K. A. have been mismanaged. We call upon him to verify (in this *Journal*, which is always open to him, not on his own paltry little dung-hill) the statement that the members of the Committee of the British Bee-keepers' Association are self-elected. There are two nuts for him to crack. He is a good hand at barking; let us see how he can lute.

His other aspersions on the Committee are not worth contradicting in detail. We shall have ample opportunity for exposing them if we think it advisable, for we expect that they will be '*continued in our next*' for some time to come. But *cui bono?* for as Pope reminds us,—

'Who shames a scribbler? break one cobweb through,  
He spins the slight self-pleasing thread anew;  
Destroy his fib, or sophistry; in vain,  
The creature's at his dirty work again.'

(*Epistle to Dr. Arbuthnot.*)

## MR. CHESHIRE'S CURE FOR FOUL BROOD.

After the reading of Mr. Cheshire's most able and interesting paper at the Conference at the Health Exhibition, we had the pleasure, in company with many of the most prominent bee-keepers, of examining the stock on which Mr. Cheshire had carried out his experiments, which had been placed for the purpose in an open space adjoining the Conference room. It contained nine combs, seven of which were, when sent to Mr. Cheshire, affected with foul brood in its most virulent form, being a mass of corruption. We, and all who inspected it, were astonished and delighted to find the case absolutely complete. There was literally not one single cell affected. Whole sheets of brood in all stages were to be seen quite healthy; young bees hatching out and eggs being laid in the vacated cells. This wonderful change had been effected by the bees alone aided simply by the administration of the medicated food. Not a cell had been uncapped nor a grub removed except by the bees; and yet those cells, which only five weeks ago were filled with dead and dying larvae, and with the putrid remains of those dead of the disease, had been cleaned out, and were now the cradles of the healthiest of larvae,—the most perfect exhibition of *Health* in the Health Exhibition. What can we say? But that foul brood is no longer to be dreaded, and to recommend everyone who has bees affected by this formerly awful scourge, to procure 'The Cheshire Cure,' and treat his bees according to the directions.

Mr. Cheshire in his paper says, 'A caution is needful. Carbolic acid is an impure phenol, and is useless. It contains creosote and cresols, and bees abhor it. Absolute phenol must be used. It is difficult rather to obtain, and so I have caused some quantities to be done up with directions, lest any should desire to experimentalise at once. It can be had of Mr. Lyon or Mr. Hollands. My fear is lest dealers should profess to supply what is required, and substitute a cheaper for an absolutely pure article; if so, difficulties will arise.'

Mr. Lyon will, we have no doubt, be pleased to associate himself with Mr. Cheshire in this matter, and to prepare this remedy under his guarantee, and also to receive applications from secretaries of County Associations who wish for a supply for their members or for sale at shows, as well as from dealers in bee-keeping sundries, as it is Mr. Cheshire's wish that the remedy may be speedily placed in the hands of all who are unfortunately possessed of the disease.

## APICULTURE AND THE EDUCATION ACT.

We are pleased to be able to report that the suggestion of the Rev. A. Leakey as to the desirability of introducing the science of bee-keeping as an element in our national education, is attracting attention, and is being favourably entertained by those who have the power to carry it into effect. The Memorial of the British Bee-keepers' Association has been laid before Mr. Mundella by the President of the Association, the Baroness

Burdett-Connis; and in his reply to her ladyship, the President of the Education Department says, that 'he will not fail to give the Memorial the most careful consideration, and bring the question to which it relates under the notice of the Department.'

Again, we note that the difference in degree of the education in populous towns and in rural districts is becoming a matter for earnest consideration and thoughtful discussion by some of our legislators. In the *Daily News* of July 16, there is a letter from Mr. Jesse Collings, Member for Ipswich, on the 'Charity Commissioners and the Endowed Schools Acts,' in which he says: 'In our towns, and other centres of industry, technical schools are considered to be absolutely necessary, in order that the children of the working-classes might acquire a knowledge of the handicraft in the practice of which their lives are to be spent. Why should not similar schools be established in rural districts? In these schools the children of the rural labourer could be practically and experimentally taught the arts of butter-making, *bee-keeping*, fruit, flower, and vegetable growing, and other matters connected with the agricultural industry. This would be one means which, if accompanied by other facilities, might give the agricultural labourer an open career on the land, and would tend to stay the rapid destruction of the peasant class now going on in England.'

We should be glad if the teaching of bee-keeping in our schools in rural districts were enthusiastically entered upon by some of the schoolmasters of our land, many of whom rank amongst the most skilful of our bee-keepers; and there can be no more effective means proposed than by making it one of those 'Specific Subjects' by which grants are to be earned. We are enabled to point to some who have already introduced bee-keeping into their schools, and who are anxiously looking to the Inspector's approval of their action in the matter. There can be, no doubt, that the children in these schools would soon be interested and would consider bee-keeping to be a pleasing relief to their other studies as being more cognate with their surroundings, and, taking an intelligent interest in the pursuit, would feel an inclination to talk about the subject when they got home, and to persuade their parents to commence bee-keeping forthwith. We cannot conceive that there could be a better mode of teaching the agricultural labourer practical bee-keeping than by it being one of those subjects which it would be the duty of the school-master to communicate to the rising generation.

## USEFUL HINTS.

WEATHER.—The weather during July, although showery and stormy at times, has been as propitious for bees as the previous part of the season; the white clover has been, and continues to be, in luxuriant bloom, the showers having prevented that scorching which sometimes destroys the blossom. Consequently, supers' have been filled to such an extent that the stock of American

sections in the hands of dealers has been exhausted, while the amount of honey on the market is to be reckoned by the hundred tons.

**FEEDING.**—Towards the middle of this month, or the end in districts where heather exists, breeding will slacken and cease for the season, when the existing bees will be all that can remain through the winter to start the brood in the spring. As they will be by first March six months old, few of them will be capable of acting as nurses, and so the population must of necessity increase but slowly until the first batch of young bees is hatched. Hence the necessity of prolonging the production of brood well into the autumn by very gentle feeding in the case of stocks well supplied with stores. But, when these have been removed by extraction or removal of the store combs, more rapid feeding may be resorted to, leaving, however, the very rapid feeding with thick syrup for stores to last the winter, until another month's time.

**CONDEMNED BEES.**—Look out for as many as you can obtain. If you do not want to increase your stocks, by all means get condemned bees, not only for humane reasons and for the sake of showing cottagers how they can save their bees alive, but for strengthening your stocks. It is a well-known fact that a large population will consume no more, and indeed very often less, stores than a smaller one, during the winter. Unless, however, you have driven bees before by no means try your 'prentice hand on strangers' bees. Cottagers naturally look upon any one who comes to drive their bees as an expert, and failure from any cause throws discredit upon the system. We purpose in our mid-monthly issue to give a more detailed description of the operation than is generally to be found in the short chapter on the subject in bee-books. In the meantime, continue to get as many combs built and stored by your own bees as you possibly can, in readiness for the condemned ones when you get them. That is, if you propose to add to your apiary by creating new stock with them.

**WASP-NESTS.**—This month wasps become very troublesome. Seek out the nests and destroy them, either by sulphur or by pouring turpentine into the entrances.

**SECTIONS.**—While the clover remains in bloom, and honey is coming in, continue to remove those which are filled, and close up the outer ones.

**EXTRACTING.**—Keep the hive relieved of surplus honey, and give the queen plenty of room for Feeding.

**HEATHER.**—Where hives can be conveniently taken to the heather, a large addition to the harvest may be obtained. As the honey cannot be extracted, sections or other supers must be provided. Great care is required in removing heavy stocks, so as not to break the combs. It is as well to extract all the honey from the combs, whether containing brood or not. Do this a day or two before removal, so that if the combs should be a little shaken in the operation, the bees can refix them firmly. Remove the supers, place over the frames a sheet of perforated zinc or canvas, open the doorways to their fullest extent, and close in

with perforated zinc. If in a wheeled conveyance, let the combs be parallel with the axle. The combs must be firmly fixed to prevent swaying from side to side. On arrival, let the bees settle down a bit before releasing them, or they may all issue like a swarm. Release them in the evening.

**SKEPS FOR TRAVELLING** should be turned up, and pieces of cork pushed down between the combs to keep them in their places. Tie them down firmly with very open canvas or cheeseware, and carry them crown down on a thick ring of hay, to act as a cushion, and prevent rolling. It is as necessary as in the case of bar-frame hives that the combs should be parallel with the axle of the cart.

## ASSOCIATIONS.

### ROYAL AGRICULTURAL SOCIETY AT SHREWSBURY.

The Committee of the British Bee-keepers' Association are to be congratulated upon the success which has attended their labours at the several annual exhibitions of the Royal Agricultural Society, and especially in regard to the one held at Shrewsbury on July 14th and following days. A large number of the officials of the B. B. K. A., and others desirous of promoting its cause were present during the show, including the Rev. H. R. Poel, the Rev. E. Bartrum, the Rev. V. H. Moyle, Mr. L. Oswald Lewis, Mr. J. M. Hooker, C. E. Fletcher, Col. Pearson, and others; and by their united efforts, aided by the Council of the Royal Agricultural Society (who generously placed their Council tent at the service of the B. B. K. A. for meetings) great results were accomplished. The Shropshire Association received new life by the election of the Rev. J. E. Charter as its Hon. Secretary, and three new County Associations were started for North Wales.

### HIVES, HONEY, AND APPLIANCES.

The tent was traversed by a large double stand down the centre and one side, and either end were stages also. Mr. T. B. Blow, of Weylyn, and Messrs. George Neighbour and Sons, of 149 Regent Street, London, occupied a large portion of the side tables, and they have a very fine collection of bee appliances, showing everything in connexion with advanced bee-culture. The Rev. V. H. Moyle, Hon. Sec. of the Borks B. K. A., exhibited (and was himself present to explain) a case containing honey, in its apical forms, whether as 'honey drops' biscuits of Messrs. Huntley and Palmor, now so largely in demand through the efforts of bee-keepers to make them known, also honey confectionery by Mr. George, of Reading, honey wine by Mr. Woodley, honey mead by Mr. Whittle, honey non-intoxicating drinks by Mr. Blatch, of Theale, viz., honey lemonade and honey nectar, also honey jubiles. The case also contained samples of wax, raw and manufactured into various articles of utility, and was very generally a great attraction as being a step further in advance in British bee-culture.

Berkshire bee-keepers maintained the honour of their Association well at this year's Show, and the large glass super of Mr. W. Woodley was much admired. The exhibits of honey were very fine in quality.

Neighbour's unicomb observatory hives for indoors, which had been awarded a prize at the Crystal Palace Bee Show, was a great novelty, attracting a great number of visitors, and was constructed with glass sides, and admitting of one comb only in width; the hidden mys-

teries of the hive are continually exposed to the full light of day; it is furnished with double glass doors, to keep up a uniform degree of heat, at the same time the view of the interior is in no way interrupted. It is constructed to take four or six frames of comb from any frame hive of standard size, and thus admit of the bees being re-transferred to a stock hive for the winter. The hive revolves on an iron axis, the entrance being in no way affected by the altered position. Mr. E. Walton, Muskhams, Newark, occupied the far end of the tent, and part of the side stage, and he exhibited a large assortment of appliances for modern bee-keeping, and a good display of honey.

The following is the list of prizes offered by the British Bee-keepers' Association:—

For the best frame hive, of a substantial character, for general use in an apiary. Price not to exceed 15s. First prize, 1l.; second, 15s.; third, 10s. 1st, Dines and Son, of Maldon, Essex; 2nd, James Blake, of Cemetery Road, Ipswich; 3rd, S. J. Baldwin, of The Apiary, Bromley, Kent.

For the best frame hive for cottager's use, with arrangements for summer and winter use. Price not to exceed 10s. 6d. First prize, 1l.; second, 15s.; third, 10s. 1st, Thomas Edey and Son, of St. Neot's, Hunts; 2nd, James Blake, of Cemetery Road, Ipswich; 3rd, J. R. W. Hole, of Tarrington, Ledbury, Herefordshire.

For the best collection of hives and bee furniture most applicable to modern bee-keeping. (Each collection to contain one or more observatory hives, stocked with bees and their queen, all combs being visible on both sides. In judging, recent improvements and new inventions will be taken into consideration.) First prize, 2l.; second prize, 1l. 10s.; third, 1l.; fourth, 15s. 1st, George Neighbour and Sons, of 149 Regent Street, London; 2nd, T. B. Blow, of Welwyn, Herts; 3rd, W. P. Meadows, of Syston, Leicester.

For the best super or honey (not being a sectional super). The super to be of wood, glass, straw, or of wood in combination with glass or straw. First prize, 1l.; second, 10s.; third, 5s. 1st, W. Bennett, of Berrington Station, Shrewsbury; 2nd, William Woodley, of World's End, Newbury, Berkshire; 3rd, Matthew Whittle, of Lockinge, Wantage—bell glass of honey.

For the best twelve 2-lb. sections of comb honey. First prize, 1l.; second, 10s.; third, 5s. 1st, J. Garratt, of Cray Valley Bee Farm, Hoekendon, St. Mary Cray, Kent; 2nd, Rev. T. B. Garland, of Ranby, Retford; 3rd, W. Bennett, of Berrington Station, Shrewsbury.

For the best twelve 1-lb. sections of comb honey. First prize, 1l.; second, 10s.; third, 5s. 1st, J. Garratt, of Cray Valley Bee Farm, Hoekendon, St. Mary Cray, Kent. 2nd, William Woodley, of World's End, Newbury, Berkshire; 3rd, W. Bennett, of Berrington Station, Shrewsbury.

For the best exhibition of run or extracted honey in twelve 2-lb. or twenty-four 1-lb. glass jars. First prize, 1l.; second, 10s.; third, 5s. 1st, James Blackham, of The Mount, Fillingley, Warwickshire; 2nd, William Woodley, of World's End, Newbury, Berkshire; 3rd, John Minor, of Wem, Shropshire.

For the best sample of comb foundation made of pure beeswax. First prize, 1l.; second, 10s. 1st, S. J. Baldwin, of The Apiary, Bromley, Kent; 2nd, George Neighbour and Sons, of 149 Regent Street, London.

#### MEETING OF BEE-KEEPERS.

A meeting in connexion with the B. B. K. A. was held in the Council tent, at five o'clock, when the chair was taken by the Rev. Herbert R. Peel, of Thornton Hall, Bucks; and amongst those present we noticed the Hon. and Rev. E. H. Feilden, the Rev. F. G. Sarjeantson, Rev. G. H. Egerton, the Rev. Mr. Wilcox, Rev. J. H. E. Charter, Rev. J. Willage, Rev. A. G. Kingsford, Rev. H. Breeze, Mr. Copeland (Shiffnal), Mr. Bennett (Shiffnal), Mr. J. Minor (Wem), Mr. A. W. Darby (Brymbo), Mr. Frank T. Rawlins (Wrexham), Mr. Baldwin, Mr. Blow, Mr. R. Hyde (Bardley Court, Shropshire), &c., &c.

The Chairman, in opening the meeting, said the object of their meeting there that day was threefold. The first thing they wished to do was to make known the princi-

ples upon which the British Bee-keepers' Association exists and works; secondly, they wished to do something towards the re-organization of the Shropshire Association, and next to establish a Bee-keepers' Association for North Wales. As to the first object, that of the Bee-keepers' Association, it is a philanthropic one. They had passed out of that stage where bee-keeping was taking up as a mere hobby. Their object is now to benefit agricultural labourers and artisans, and great success had attended the effort already. Men have already made considerable additions to their incomes by keeping bees. He would not go into statistics how much a man could make. He would only give them one instance, that of a labourer who has already taken from one hive fifty sections which he sold at considerable profit. The first two sections he sold at about 2s., the next at 1s. 9d., and the rest at 1s. If one man could do that, every man could do it. They had plenty of instances also of ladies being successful in the keeping of bees. One lady—Miss Gayton of Hadham—made 60l. last year out of bees, and it was not a good season at all; and they wished to benefit the labourers in the same way. They found that the best way to promote the object they had in view was to form county associations, to divide the county into districts, and to have an energetic acting secretary in each district as well as a county secretary, for by that means each labourer could be reached. It had been done in other counties—in many counties in England, and some not very far from there. If it could be done in other counties he did not see why it should not be done in this. As to the Shropshire Association, he was afraid it was rather in a state of abeyance. It was like a hive without a queen—there was not much driving in it. They hoped, however, that day some gentleman might be found who would be willing to undertake the secretaryship, to re-instate the Shropshire Association, and to make it a good working county association, deserving of the prestige which the association has already gained for Shropshire, for the Shropshire Association was one of the oldest associations in existence. A gentleman, who was present had been named as the county secretary—the Rev. J. H. E. Charter. He lives in Shrewsbury, is a most successful and enthusiastic bee-keeper, and if elected county secretary he would form the centre of a number of district secretaries, who would all work under him, and the society could be soon put in working order. Then as to North Wales—when the Royal Agricultural Society held its meeting at Cardiff, the Bee-keepers' Association had a department in the show-yard, as at Shrewsbury this week, and many came there and saw the manipulations, and felt what an advantage it would be to the cottagers and labourers in South Wales to have such an association. Since then many other counties have formed associations, and a great deal had been done in the way of instructing cottagers. If the visit to Cardiff was productive of much good results, he hoped their visit to Shrewsbury would be equally so, and that other societies would spring up in Shropshire and North Wales. It seemed to him that there were plenty of bee-keepers in North Wales if they could only be brought together. The first thing, however, was to have some gentleman who would take the trouble to be a sort of focus, and around whom others could be collected. The Chairman then suggested that the Lord Lieutenant of the county might be invited to act as President, for he was always supposed to be superior to all party politics, and assured the meeting that if such a step were taken as that suggested the Central Association would render every assistance. He could only say, in concluding his remarks, which he wished to make as short as possible, as their meeting was held necessarily late, and they could not have the use of the tent until five o'clock, the British Bee-keepers' Association's headquarters were in London. The President's name was a guarantee of the value of the society, and shows that it was not of a make-belief character. They would be very glad to help any

gentleman who wished to assist in their county. They could give them material assistance by supplying papers and forms very useful to those inclined to form an association, and next by encouraging any county by offering silver and bronze medals, and would give them the loan of a bee tent for any chief or principal show they wished to hold in the county. If any gentleman cared to organize a series of lectures they would give addresses on bee-keeping, and teach as much as they could do orally. In the bee tent they always found a competent expert to come down to show them practically how to manage bees, as Mr. Baldwin had in the tent that day. These were the chief means of assistance which they offered to those inclined to form a county association. It was often said it was very well to teach cottagers to produce large quantities of honey; but what were they to do with it after they got it? Where were they to find a market to sell and dispose of their honey, which of course was the chief point to increase their income? He did not intend to answer that question himself, but they had present that day Mr. Moyle who was solving the question by establishing a large depot at Reading. He would ask him to give an account as to how it was carried on now, and what he expected for the future.

The Rev. V. H. Moyle, secretary of the Berkshire Association, spoke of the importance of the resources of the kingdom being developed as far as possible, and strongly urged the establishment of bee-keeping associations in every county; and as by far the greater part of the country was now covered with a network of such societies, it was high time that North Wales evinced a healthy desire for such organizations; indeed, he had received many proofs that there were many in the different counties of North Wales willing to work together for the common good if only they could be started aright; and he was quite sure his friend, Mr. Peel, would be found here, as he had been elsewhere, a pioneer in the good cause. Mr. Moyle gave an account of the rise and progress of the Honey Depot at Reading and in London, and hoped that the question of utilizing the honey in every possible way after we had secured it would receive the very earnest attention of bee-keepers, either in the way of food, beverages, medicine, or any judicious channel.

The Rev. Mr. Wilcox, of Cuckshutt, moved the first resolution, "That it is desirable that the Shropshire Beekeepers' Association should be reorganized." This was seconded by Mr. J. Minor, of Wem, and the resolution carried unanimously.

The Chairman said the name of Mr. Charter as Secretary was a host in itself, and he believed he was the right man in the right place. Would Mr. Charter say that he would accept the position?

The Rev. J. H. E. Charter, who was received with applause, said, that should be pleased to do anything he could; in fact, do his best.

The Hon. and Rev. Feilden spoke in approval of the Society and its objects, and said that he would do what he could to promote the Society in Shropshire and North Wales.

The Chairman then drew the attention of the meeting to the necessity of appointing a Chairman, and it was agreed that the Rev. J. H. E. Charter should write to the Lord-Lieutenant of the county to accept the position of president. The Chairman also said, that perhaps some one reading the report of the proceedings would take the matter up in North Wales, and the Secretary of the British Beekeepers' Association would give them all the information and assistance in his power.

The Rev. V. H. Moyle proposed a vote of thanks to the Chairman.

The Rev. H. Evans seconded the motion, which was carried.

#### STAFFORDSHIRE COUNTY BEE-KEEPERS' ASSOCIATION.

The Bee-tent has already attended shows at Endon, on May 29; Milton, June 06 and 17; Burton, June 25; Mabley, June 27; Hanley, July 15 and 16; Tunstall, July 21; Stafford, July 23; Stoke-on-Trent, July 24; West Bromwich, July 25 and 29.

The British Bee-tent is engaged by the Association for Hoar Cross Show, on Aug. 4.

One hundred and five new members have joined the Association during the present year, and bee-keeping is rapidly growing in popularity in the county, under its scientific influence.

#### CALEDONIAN APPIARIAN SOCIETY.

The eleventh Annual Show of the above Society, on July 22, 23, 24, and 25, has been the most successful one they have ever had, and was the best of its kind ever held in Scotland. For the last eight years they have exhibited in the Highland and Agricultural Society's showyards, commencing in Edinburgh in 1877, and have followed in the wake of the above society, visiting in turn Edinburgh, Dumfries, Perth, Stirling, Kelso, Glasgow, Inverness, and again in Edinburgh on the present occasion. During that time it may be said to have well fulfilled its mission, having shown the mysteries of the bee-hive and the produce of bees to the classes in the country, by whom in the future we expect most to be done in this branch of agriculture. Although for Scotland the show always takes place a month too early for a display of the fine heather honey, yet there were nearly two tons of the most beautiful honey, and presented in the most saleable form, which attracted the honey merchants and private parties as purchasers to such an extent that very soon all seemed to be disposed of. Dumfries, Wigton, Ayr, Dumbarrow, Arzlyl, Lanark, Perth, Stirling, and Forfarshire, all sent their quota; and Mr. Paterson of Struan sent 12 lbs. of this year's bell-heather honey, which, being so early in the season, is a feat quite unprecedented. The Messrs. McNally of Glenelg, Wigtonshire, showed what can be done by industry and perseverance, and exhibited about 700 lbs. of splendid honey, well put up, and were awarded the Highland Society's silver medal, besides disposing of all their honey on the ground. Their success is all the more remarkable, as they have been only three or four years at bee-farming. The quantity and quality of the exhibits being exceptional, the judging necessarily became a rather difficult matter; but the hon. secretary, Mr. Bennett, was equal to the occasion, and had secured the services of gentlemen whose names were sufficient to allay any fear in the most suspicious minds. Messrs. Neighbour and Rait were judges in the honey section, and had no easy task, the quality having been rarely equalled. The name of the sender was in one or two instances labelled on the exhibits, which was unfortunate, as, being against the rules, they were excluded from competition. Messrs. Buchanan and Patrick were judges of the bees and hives, and their work was unusually tedious, as they had no less than twelve Observatory hives to examine, three or four of which were on entirely new principles. These hives were of great interest, and afforded much information as well as amusement to the visitors. Messrs. Loughland, Armstrong, and Anderson, were judges of wax, comb-foundation sheets, meal, cakes, &c. As there are so many makers of these now in the market, this branch of apiculture is now brought to great perfection. The Driving Competition was a source of great interest to the visitors, and some of their remarks provoked some merriment amongst the operators. As in the two last years, Mr. Johnston of Touch, Stirling, was the successful competitor.

A feature of interest at this exhibition was the essay on bees by Mr. William Thomson of Blantyre, which gained the Highland Society's prize for 'The Best Essay

on Bee Culture.' It was decided, we think wisely, to publish it, and we trust it will command a very extensive circulation. The book is well got up, profusely illustrated, and contains much and valuable information. The weather, an important matter in such exhibitions, was all that could be desired, except on the third day, when rain fell heavily from midday and onwards.

#### COUNTY BEE-KEEPERS' ASSOCIATIONS FOR NORTH WALES.

Persons desirous of becoming members, and assisting in the formation of Bee-keepers' Associations in the following counties, are requested to send in their names and addresses as early as possible; viz., for Denbighshire, Edward Windsor Davies, Esq., Penrhosward, Eghwys-fach, R.S.O., Denbighshire; for Carnarvonshire, W. Arthur Dow, Esq., Wellfield House, Bangor; for Flintshire, Mr. G. Spencer, Hawarden.

Hugh Robert Hughes, Esq., Lord-Lieutenant of Flintshire, of Kimmel Hall, Abergele, has accepted the office of President of the Flintshire Association.

#### ISLE OF MAN AGRICULTURAL SHOW.

Some prizes for Manx honey, &c., are offered for competition at the Isle of Man Agricultural Show to be held at Ramsey on Thursday, August 7th; and there is to be at the same time a small exhibition of bee-keeping appliances. All gentlemen proficient in bee-keeping who will then be visiting the Island, and willing to render assistance in judging or explaining, are invited to send in their names to Mr. James Moore, Victoria Street, Douglas.—G. DRINKWATER.

#### FORFAR BEE-KEEPERS' SOCIETY.

The fourth annual exhibition of bees, honey, and hives, of the above Society will be held in the Town Hall, Forfar, on Saturday, 30th August.

#### BRITISH BEE-KEEPERS' ASSOCIATION.

On Friday, July 25th, at the instance of the Executive Council of the International Health Exhibition, a Conference of the British Bee-keepers' Association was held in the Large Jury Room of the Exhibition Building. The bee-keepers mustered in large numbers, among whom were the Revs. H. R. Peel, G. Raynor, E. Bartrum, Hon. and Rev. H. Blich, Revs. F. T. Scott, C. F. G. Jenyns, F. S. Schater, J. Lawson Sisson, Wilkinson, &c. Captain C. D. Campbell, Messrs. B. Athawes, T. B. Blow, G. F. Boller, W. H. Dunman, J. Garratt, R. Green, W. N. Griffin, Hart, J. D. Harverson, G. D. Haviland, O. Helmer, G. Henderson, J. M. Hooker, W. Martin, F. Lyon, H. L. Mills, Roberts, Hollands, &c.; Miss Gayton, Mrs. Cheshire, &c.

The Rev. H. R. Peel was called to the chair. The Chairman having introduced the lecturer, Mr. F. Cheshire proceeded to read his paper on

#### FOUL BROOD (NOT MICROCOCCUS, BUT BACILLUS), THE MEANS OF ITS PROPAGATION AND THE METHOD OF ITS CURE.

Mr. President, Ladies, and Gentlemen,—About two months since I was invited by the Committee of the British Bee-keepers' Association to address the present Congress, then to be convened in connexion with the International Health Exhibition, on the absorbing but apparently well-worn topic of Foul Brood. My consent to that invitation was mainly given on two grounds: first, a confidence that I had a method of curing this terrible malady far in advance of any that had previously been brought before the bee-keeping community either by others or myself; and, secondly, that the writing of the paper would furnish me with an excuse and reason for that large devotion of time which I fore-

saw a new and independent investigation of the subject from its scientific side would require,—an investigation which I had long intended to undertake, in order to test facts which I had noted during previous years, and which it seemed impossible to reconcile with commonly received opinions. To these facts and to the results of my recent inquiry, so far as I have as yet been able to complete it, I now therefore ask your kind and indulgent attention, in order that we may all apprehend together the grounds upon which I venture to diverge somewhat widely from theories which have been admitted during the last seven years at least as things undisputed, because indisputable.

Apiculture is attracting more attention in this country than it has ever previously received. Bee-keepers are multiplying on every hand. The peerless late Hon. Secretary of the B.B.K.A. will know no rest until every county has its Association. From the throne to the humblest cottage the charms or the profits of apiculture are getting recognition. The bee-keeping of to-day is no more like that of the first half of this century than the goods train is like the carrier's cart. We have our combs built in days instead of weeks. Bees raise drones or workers as we give them order. Supers have gone and sections are finished as though bees had recently learned the use of the rule and the plumb-line. Honey is demanded by the ton in the manufacture of biscuits. The poor cottager may add to his comforts and his culture by attending to his hives; and yet, amidst all this pleasant prospect, seeming to promise greater things for the future, a dark cloud—causing most to fear, and even breeding despondency in the breasts of not a few apiarians—is hovering amongst us. Foul brood, despite all the information given, is now not only present, but rapidly increasing; and were it just to the owners I could point not to diseased stocks merely, but to apiaries of sixty or eighty, where, perhaps, not one has escaped contamination. Letters daily, and lately almost every post, arrive with some sad tale of disaster which the writer fears will perforce ruin the hive-selling business which has grown up in company with his bee-keeping. If the unqueening and comb-excising or burning and starving plans must be adopted, ruin is meant, profit anticipated becomes loss realised, and hope yields to despair. Nor is the reason of this far to seek. In former days, when bees were kept in the same garden, descending from father to son, increasing their number in the spring by swarming to be reduced to the old limits in the autumn by the sulphur-pit,—when none left their native spot, except an occasional swarm, perhaps, as a gift to a near neighbour, and when none were ever imported from afar, foul brood might have lurked here and there, but the facilities for its propagation were wanting. Now, how different! Bees are ever travelling by our railways through the length and breadth of our land, these, raised often in company with many stocks where are to be found queens hailing from the Sunny South, where the disease has been often rampant, and coming, as these swarms sometimes may, from stocks not above suspicion, are, it is to be feared, but too often the instruments for communicating the germs of destruction in localities previously free. I delight, however, to recognise that this sad state of things need not, and I believe will not, continue, for, from reasons which will be presently apparent, instead of now regarding a visitation of foul brood in my apiary as a terrible disaster, I should esteem it as a trifling and temporary inconvenience very far less grave than the loss of a queen. Let us now consider the subject under three heads. Firstly, the nature of foul brood as a germ disease; secondly, the means of its propagation; and, thirdly, the methods of its cure.

*The Nature of Foul Brood as a Germ Disease.*—The appearance of foul brood is undoubtedly familiar to almost all before me. A larva, if attacked early, begins

to move unnaturally, and instead of lying curled round on the base of the cell frequently turns in such a way as to present its dorsal (back) surface to the eye of the observer. A little attention will then show that the colour of the larva is inclined to yellow instead of being pearly white. Such grubs are only rarely sealed over. Those more advanced before the disease strikes them are in due course sealed, but death overtakes them, their bodies become brown and foetid, and the sealing sinking gets pierced by an irregular hole. From this may be gathered the general indications of the disease, which is usually accompanied by very energetic fanning at the hive mouth, from which in advanced cases an indescribable and nauseating odour is emitted. The larvae and chrysalids dead of the disease dry up to a coffee-coloured, tenacious mass lying at the bottom of the cell, so tenacious, indeed, that it may be drawn out into long threads like half-dry glue. The drying process completed, a blackish scale is all that remains. This was formerly supposed to be the only condition in which the foul-broody matter so called was a centre of infection, but we shall presently discover that this notion has no foundation in fact. The disease is terribly contagious, and once started soon spreads from cell to cell, and not infrequently from stock to stock. The knowledge of bee-keepers extended little beyond this in December 1874, when a translation from the German by Mr. J. S. Wood, of Nyborg, gave an account of some experiments by Dr. Schoenfeld, which may be thus summarised. Some foul-broody matter was placed on a plate pierced by a hole, below which, and passing into it, was a glass tube 2 ft. long, a bell-glass covered the plate, and bore another tube inserted into a hole in its crown. The lower tube was perfectly open, but the upper one was plugged loosely with cotton wadding. The sun shining on the glass warmed the contained air, and a current was produced. Dr. Schoenfeld describes the foul-broody matter as being full of micrococci, and, examining the cotton wadding, he tells us he discovered innumerable micrococci. Some of this wadding was placed over larva in a hive, and the larvae were removed three times, but upon the fourth experiment seven larvae died, their bodies being found full of micrococci. He also informs us that blowdy larvae, by the cotton wool being placed upon them, contracted the disease, and the bodies upon examination revealed innumerable micrococci. These experiments were accepted as so satisfactory and conclusive that the matter here rested; and again and again I examined microscopically, specimens of foul-broody matter sent to me without for a moment suspecting the very serious error underlying these observations, upon which I do not wish to cast any discredit, although two very accomplished microscopists whom I have consulted agree with me that any supposed observation of micrococci on cotton wool could only be accepted with extreme caution.

But the fact of being able at once to spot foul brood by a microscopic examination of the coffee-brown matter was an advantage. In October 1879 a well-known bee-keeper sent off two small brown masses found in a super, one to the *British Bee Journal* and the other to the *Journal of Horticulture*. The latter came to myself, and I pronounced it foul-brood instantly I saw it under a power of 500 diameters. The *British Bee Journal* affirmed it simply dried pollen, a pardonable mistake. But the bitter scolding I received in the aforesaid *Journal* for my folly in pronouncing this to be foul brood induced me to visit the apiary from which it came, and in which every stock turned out to be a prey to the dread malady. The microscope here was the means of starting remedial measures ere too late.

In spite of all that has been written or said since that time, we appear, so far as the nature of the disease is concerned, to have made no advance. The expressions 'Bacteria,' 'Fungus,' 'Micrococci,' have been used without any very definite ideas lying behind them,

and there the matter apparently has rested. Before attempting to explain what I venture to believe the disease actually to be, it will be necessary to give a few definitions and explanations.

Science has recently shown that all putrefactive changes, fermentations, and very many diseases, are brought about entirely by minute organisms, which are in fact rudimentary vegetables. To them the general name of Schizomycetes has been applied, because their method of increase is by splitting or fissuration.

These micro-organisms are divided into four genera—micrococcus, bacterium, bacillus, and spirillum. We shall presently see that two only of these, micrococcus and bacillus, are essential to our present purpose, and so the others will be left out of view. There are many species of each, and they may be classed as,—septic, those causing putrefaction; zymogenic, causing definite chemical changes, such as butyric fermentation; chromogenic, or colour-forming, and pathogenic, or disease-producing. Confining our inquiry within the narrowest possible limits we have to do with pathogenic micrococci and bacilli. The former may be roughly described as minute globular bodies, which at intervals become slightly elongated, and then show a compression at what may be called the waist, giving them the form technically known as the dumb-bell. The compression becomes more pronounced until by separation two tiny globes are produced from the one; each of these will in turn divide, and so multiplication may go on at an astounding rate. Bacilli, on the contrary, are rod-shaped, and if we could suppose a common ruler to elongate without increasing in thickness, and then at a definite point break into two, to again increase in each part in like manner, we should have a fair idea of the whole matter; but sometimes this increase in length is not accompanied by separation, so that a line of bacilli may be formed comparable to a long string of sausages, and such is denominated a leptothrix. Under certain conditions, however, the bacilli produce spores (or seeds), which the micrococci never do; while in addition bacilli, unlike micrococci, are provided at their extremities with wondrously delicate filaments called flagella with which they strike the fluid containing them, and so swim much as a fish does by the use of its fins; so that shape and the power of spore-production and self-directed locomotion sharply divide one from the other.

This explanation, for the introduction of which no apology is needed, since upon it turns a right understanding of the line I took in the inquiry, will, I trust, be sufficient to enable even those who have not studied the question of micro-organisms at all to follow the details now to pass before us, concerning which I must express my thanks to G. F. Dowdeswell, Esq., M.A., member of the Council of the Royal Microscopical Society, for the lively interest he took in my investigations, and for the many helpful suggestions he gave me. I happily mentioned to him at one of the Royal Microscopical Society's meetings the work in which I was engaged.

Taking a small quantity of the juices of a healthy grub, and spreading it out under a thin glass under the microscope, one is presented with such an appearance as is seen at fig. 1, fat globules are numerous, while blood-discs abound, and everywhere may be noticed tiny particles which are constantly slowly dancing with what are called Brownian movements; but if a speck of coffee-coloured, foul-broody matter be similarly treated, we find neither fat globules, blood-discs, nor molecular base, but observe the field crowded with very small ovoid bodies, as we have them represented at fig. 2. These are the micrococci of Schoenfeld, but if this substance be stained according to the modern plan of Weigert and Koeh, and then carefully examined, in all probability we shall discover, associated with the ovoid bodies, a very few other organisms, longer and rod-shaped, while

we notice that the so-called micrococci are neither round dumb-bell like, but oval, or boat-shaped. This led me at once to suspect an error, and further searching showed

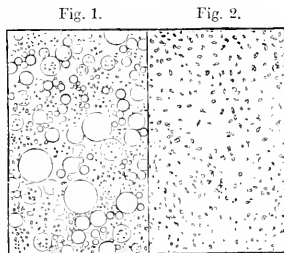

Healthy juices. | Foul Brood, last stage.

me if, instead of coffee-coloured matter, such as that usually sent for microscopic examination, the body of a grub, dead, but in a fresher condition, were taken, the number of the rod-like bodies very considerably increased, while that of the ovoid ones diminished, as seen in fig. 3. My own inoculated stock, inoculated for experimental purposes, — was cured, and gave me no material, but soon I obtained a comb from a suffering hive, and then had the opportunity of expressing the juices from a death-stricken larva. These, when examined under a power of 600 diameters

Fig. 3.—Late stage.

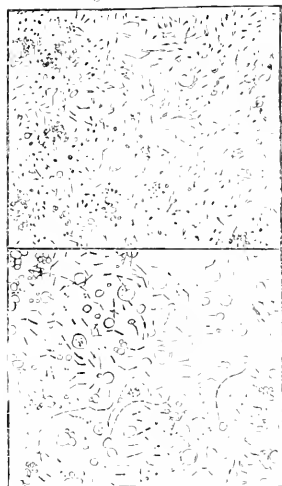

Fig. 4.—Early stage.

and carefully illuminated, were seen, to my great delight, to be full of active rods, swimming backwards and forwards, and worming their way between the degenerate blood-discs and fat globules, as represented in Fig. 4, while here and there were long strings of them, the leptothrix form previously referred to. Three questions now required answers. Was this undoubted bacillus always associated with foul brood? If so, was it cause or effect? If the cause, what was its life history? It would weary to explain how these answers were obtained, as the work involved many days' incessant application at the microscope, the preparation and comparison of about

200 microscopic slides, and the rough or somewhat careful dissection of at least 100 grubs, taken from various hives, in different conditions of the disease, and at sundry periods after their removal from their respective stocks. I found that in every instance the beginning of the attack was marked by the appearance of bacilli in the blood, that these bacilli were in many cases at first long, thin, and marked by the presence of bead-like points; that as this form disappeared the bacilli, pure and simple, multiplied by repeated division, that these bacilli, when magnified about 1300 diameters, presented the appearance seen in Fig. 5, that those were active,



Fig. 5.

Fig. 6.

swimming rapidly either backwards or forwards, and that when an end view could be obtained of one of them, it was seen to be describing a small circle; that when the disease was in rapid progress leptothrix forms were common, some of them reaching even the 1-100th of an inch, or 250  $\mu$ \* in length; that as the fluids of the grub failed by loss of fats and albuminoids, the bacilli put on the spore condition. They widened and drew up their protoplasm or mycoprotein from their extremities, as we see indicated in fig. 6, and thus became what Schonfeld had in error called micrococci.† That after the death of the grub, and during the assumption of the viscid, putrid condition, this constant alteration of bacilli into spores continues. After removal from the hive it goes on so rapidly that in three or four days scarcely a bacillus as such is discoverable, but the spores are innumerable. The reason of Schonfeld's mistake so far is intelligible, he saw the spores only, and judged them to be micrococci; but the continuance of his error through all his investigation is a mystery which I am quite unable perfectly to explain.

Foul brood, then, is a bacillus disease; and in these days, when the 'germ theory' is the question of questions amongst pathologists and physiologists, it is extremely interesting for us to note that science has lately shown that different species of bacilli also cause consumption, cholera, typhoid, leprosy, and many other diseases afflicting the human family; whilst amongst animals, glanders, splenic fever, septicæmia, &c., arise from a similar cause. This particular bacillus seems not unlike *Bacillus anthracis*, which the researches of Pasteur have lately brought so much before public attention. Since the force of conviction thus obliged me to contradict the conclusions of Schonfeld, I felt it incumbent upon me to repeat his experiments: for if the disease be really a bacillus, how could the communication of it to the larvae of *Musca vomitoria* (blowfly) produce, as he says, micrococci in that insect? I experimented on 60 individuals: 20 were not brought near foul-broody matter, 20 I attempted to infect with bacilli in their active condition, and 20 by spores. At the end of 24 hours I examined carefully two from each lot, but with no apparent result. In 24 hours more, two again, but still failed to see any evidence of disease. By a further delay of 24 hours, one of those infected with coffee-coloured matter was found to have a pretty considerable number of active bacilli swimming in its fluids. The non-infected showed many micrococci. This was most completely confirmatory of my position; but how could it be reconciled with

\*  $\mu$  or micromillimetre =  $\frac{1}{25.4}$  inch nearly.

† The greater number of bacilli in this way produce two spores. The determination of this point requires extremely careful illumination and high powers of fine quality. The other facts may be witnessed by a good quarter, aided by an achromatic condenser.



Schonfeld's assertion, that he found the dead flies full of micrococci. Had he searched further, he would have discovered that dead blow-flies are generally full of micrococci. They take in with their food (decomposing flesh substances) swarms of septic micro-organisms, and these at their death multiply within them; but any observation carefully made with a decent instrument would show the immense difference between these micrococci and the spore condition of the bacillus. Schonfeld's last assertion that by means of these micrococci he established foul brood in the larva of the bee, and found these larvae containing innumerable micrococci, is past my comprehension. The only solution, if we accept these statements, that I can at all suggest is that the Brownian movement of the molecular base of the fluids was mistaken for micrococci; but this supposes most unskilful observation and possibly a very poor instrument, while, for anything I know, Dr. Schonfeld may be possessed of ample skill and elaborate appliances.

I cannot refrain from expressing my conviction that it is much to be regretted that some leading name out of experiments, to all appearances conclusive and complete, should have been given to the apicultural world. In their absence, it is hardly possible that we could have all been in the dark so long. I find in my notes that actually eight years ago I saw these bacilli, and should very possibly have not allowed the observation to drop unless I had felt that the question of foul brood was a sucked orange. Not a few others of us from a similar cause have been kept from the path of discovery.

But in yet another way I have striven to prove irrefragably that the etiology I have given is correct. Taking a number of well-developed drone larvae from a healthy stock their juices were expressed and strained into two test tubes 3 inches long and 1/2 inch wide. No. 1 now received a very minute quantity of coffee-coloured matter containing spores, mostly, while No. 2 was infected with a trace of bacillus-containing fluid from a larva just dead. These test tubes were each supported by a tin slip having a hole in its centre through which the tube passed, but the lip could not, and they were thus suspended loosely hooked between the frames of a stock so that the exact temperature for germination should be kept up. In twenty-two hours, I found the spores had in large part disappeared, and that bacilli in threads existed in considerable numbers, while the bacilli added to No. 2, were increasing by division, proving again that the spores produce bacilli so soon as they pass into conditions for germination, the reverse process obtaining when these conditions cease.

For many years I have entertained the conviction that the often-repeated statement that the disease affected the brood only was not merely not proved, but opposite to the evidence at our command. This statement has been again and again made as though it were as certain as that two straight lines cannot enclose a space; but I am glad to note that Mr. Cowan has shown that deeper insight which is the outcome of scientific training as he merely says: "foul brood does not seem to affect the bees."

We may take away two or three frames containing 5000 larvae each from a stock, and it will continue to progress pretty much as though it had lost nothing while if foul brood attacks and kills say 1000 of its grubs, it, as a rule, very perceptibly diminishes in strength. The only explanation that appears is that the bees die with the disease, but that according to a necessary instinct they leave the hive and finish their course alone. I, therefore, resolved to try to settle this point. Going to the experimental hive, then in my possession, I noticed one bee nearly dead on its back, another hopping in abortive flights of 3 or 4 inches, and presently found a third and fourth worn out and too far gone to enter the hive again. The first bee contained nothing re-

markable, but the second was almost an empty shell, the air sacs occupied nearly all the abdomen. The stomach and colon were exceedingly small and the amount of fluid I could obtain truly microscopic, but this was enough for the microscope, which showed it at once as full of active bacilli. The question was answered. The large consequences flowing from it were clear. Swarms must no longer be stated as incapable of carrying the disease. Bees from a presumably clean hive if in an infected apiary may carry the infection. And so, to set all at rest, I placed the bee in spirits and now offer it to the Committee of the B. B. K. A., who may, if they please, put it into the hands of any microscopist of repute for examination; but this bee is not needed, for Nos. 3 and 4 gave me similar results, and so have some others since, making it clear that a very large proportion of imago (adult) bees from a foul-broody stock, die of bacillus, or, as Mr. Booker remarked to me a few days ago when talking of this matter, "In a foul-broody stock the candle is burning at both ends."

This discovery is pregnant with consequences. As workers and drones are liable to it, why may not queens suffer from it? Although I have had, of course, no opportunity of giving direct evidence here, analogy says they must and if so, may not those who assert that imported queens have introduced foul brood be after all right? In a case occurring to myself last year, a Ligurian queen was successfully inserted and laid fairly, but foul brood appeared and she died. At that time I did not connect the circumstances, but they rise to my remembrance and bring a doubt. Further, if the queen may be infected, why not the egg? So far as I have been able to go, I believe it occasionally is. Some would say the size of the egg would forbid this, but these spores are relatively minute. The egg is 1/2 of an inch long and 1/4 inch in diameter, yet it could contain above 100,000,000 bacilli in the spore condition, the spore being no more in relation to the size of the egg than a single drop would be in a cistern containing 1500 gallons of water. The investigation of this point I must leave to others or to the future, as it may be necessary to infect one of my stocks, and that would also appear to be necessary to infect the queen to get the eggs in proper condition; but great caution will have to be exercised as the sources of error are so numerous and the manipulations so difficult, but an example in point is at hand which shows that the idea is not improbably correct. "Carpenter on the Microscope," p. 375, says:

"A most notable instance of such propagation is afforded by the spread of the disease termed 'Famine' among the silkworms of the south of France; the mortality caused by it being estimated to produce a mortality of from three to four millions sterling annually for several years following 1832, when it first broke out with violence. It has been shown by microscopic investigation that in silkworms strongly infected with this disease, every tissue and organ in the body is swarming with minute cylindrical corpuscles about 1/100th of an inch long; and these even pass into the undeveloped eggs of the female moth, so that the disease is hereditarily transmitted. And it has been further ascertained by the researches of Pasteur, that these corpuscles are the active agents in the production of the disease which is engendered in healthy silkworms by their reception into their bodies, whilst if due precaution be taken against their transmission, the mortality may be completely exterminated."

A matter for consideration now presents itself of some moment. The name foul brood has been given under a misapprehension, and is manifestly inappropriate since the disease is not specially of the brood at all. Popularly it may yet pass, for the title is so crystallized into bee literature that it would be difficult to displace it, but scientifically it cannot be admitted, I, therefore, with due respect claim the discoverer's privilege of

\* The bee is now in Mr. Huckle's keeping.

giving a name which shall represent generically and specifically what the disease really is. I suggested to the Rev. Herbert R. Poel that he should be sponsor to a new name meaning Bacillus of the hive. He consents, but his sponsorship will, I am sure, in this instance, consist not in training and guarding, but in pursuing to the death that terrible and noxious pest hereinafter to be called *Bacillus alvei*. Let us now turn to our second point.

2. *The Means of the Propagation of the Disease.*—Although the methods of propagation of this disease are in all probability varied, and, as yet, not in detail fully understood, it may be said without hesitation that the popular idea that honey is the means by which it is carried from hive to hive, and that mainly through robbing, is so far an error that only occasionally and casually can honey convey it from stock to stock. I have searched most carefully in honey in contiguity with cells holding dead larvae, have examined samples from stocks dying out in rotteness, inspected extracted honey from terribly diseased colonies, and yet in no instance have I found a living bacillus, and never have been able to be sure of discovering one in the spore condition; although it must be admitted that the problem has its microscopic difficulties, because the stains used to make the bacilli apparent attach themselves very strongly to all pollen-grains and parts thereof, and so somewhat interfere with examination. This is quite what would have been anticipated, because honey by its very viscosity is somewhat anti-septic, and the rapid movement of these especial micro-organisms, which seem essential to their propagation, is prevented by it. I have tried infecting honey and growing bacilli in it, but without the smallest approach to success.

Nevertheless, to feed honey taken from foul-broody hives (or, as I ought to say, hives infected with *Bacillus alvei*) to healthy ones without taking some precaution would be absurd; but holding is neither the most convenient nor the best plan, as we shall see presently. I anticipate here the question, Is honey taken from diseased bees fit for human food? Morally, I should object to sell for table purposes honey which had been stored in the factor of a diseased stock, but scientifically I could see no cause for impeachment if the flavour of the honey were good, for the chance contamination of a bacillus would be no risk. Even pathogenic bacilli may be swallowed, apparently without harm, if there be no internal rupture of the mucous membrane, while human saliva, containing as it does micro-organisms, derived from the air, will often kill small animals if a particle of it be inserted beneath their skins.

My belief is that the grubs are most usually infected by the antennae of the nurses. These travelling in the darkness of the hive become aware of the condition and needs of each occupant of the brood-cells by constantly inserting their antennae, which must continually, where disease reigns, be brought into contact with larvae full of bacilli, and also into contact with those sticky masses into which the larvae change about two days after death. The removal, then, of spores is highly probable, and these transferred to the next grub fed will there start the disease. These sticky masses will be found, too, to extend to the very front of the cells, and as the bees perambulate their combs, the claws, or more probably the pubiculi, which stand between them will be in danger of removing spores, and depositing them upon other cell-edges, to infect other grubs at the critical time of e-conspinning.

The supposition that in the dried condition of the dead larva the micrococci (?) are thrown off into the surrounding air must be replaced by facts founded upon observation. The first authorities are in general agreement that micrococci are not thrown off at all; and even if their opinion stood the other way, it would not affect the question, since I hope I have

successfully shown that no micrococci exist in these dried larvae. If it were otherwise, the face of every honey-cell would be closely dusted with death-dealing germs, and the case would appear hopeless; but this is not contradicting that it is possible, or even extremely likely, that the tramp of the bees does frequently detach numbers of spores which fly about in the air, and settle here and there, often where they take effect, many of them being carried into healthy stocks by the in-draught set up by the fanners. When a hive is robbed, I strongly incline to the belief that it is rather the feet and the antennae which carry infection home with the robbers than the honey in their sacs. Indeed, the ordinary opinion would appear to have no better foundation than very many other of the guesses which have impeded the progress of truly scientific apiculture; and I find Mr. Cowan remarking nearly six years ago, 'The honey which is supposed to contain the spores, although I must say I have never been able to detect any by the microscope.' This part of my subject is extremely difficult of positive proof, but with a body of facts before us our conclusions are not likely to be seriously wide of the mark. A very large number of observations has shown me that the disease is not found at all, except as infrequent exceptions in the digestive tube of the larva, but it lies wholly and absolutely in the blood; but did honey convey it we should certainly often see its traces in the alimentary sac. In the adult bee, on the contrary, the disease, although present in the blood, is generally very acute in the chyle stomach, and the effects seem to be those of consumption of the bowels. The reason for the difference I have no time now to explain, but will simply point out what I believe no observer but myself has discovered,—that the bowel of the larva is cast off with the skin at the time the chrysalis condition is assumed, and that the digestive apparatus of the imago bee is an entirely new and different organization from that possessed in the larval state. The size of *Bacillus alvei* is exceedingly minute, about  $1\mu$  in diameter, and from  $3\mu$  to  $5\mu$  long, or, to put it popularly, such that a quadruple string of them extending from London to New York could be formed out of one cubic inch of material. Ordinary dust-motes to these organisms would be like hens' eggs to sand-grains, so that the difficulty, if any had been felt, respecting their being carried about, should vanish. Nor is their multitude less astonishing. I have examined many grubs which must at least have contained 1,000,000,000 of them. A statement which, after inspection of the many microscopic slides I have prepared, will be accepted without question. In the royal jelly, so called, of a queen dead of bacillus, I could discover no bacilli, nor have I succeeded better with the food provided to the workers, notwithstanding that I examined several hundreds of the cells containing feeding grubs, surrounded by dead larvae; so that, although I would not dogmatise, my strong opinion is, that commonly neither honey nor pollen carry the disease, but that the feet and antennae of the bees usually do. I also think it probable that occasionally, at least, nurse-bees infect and bring the disease-germs to the mouth in feeding the larva, and then turning foragers, have a germ or germs in the nectary of a flower, which visited by another bee becomes the means of infection to it; the maledy is thus carried by adult bees into other, and perhaps somewhat distant, apiaries. Baancing all the probabilities, it would appear that most generally the adult bee takes the disease, and then carries it directly or indirectly to the brood. An ailment of a rather different kind, from which the house-fly suffers, is known to take effect by its germs settling on the spiracles, or between the abdominal rings. The spiracles of the larva of the bee may also be the especially vulnerable points. But it is time I hurried on to the third, and practically the most important, section of my paper.

*The Method of Cure.*—Those whose apiaries are suffering from the ravages of foul brood have had two classes of advisers: those recommending curative measures, and those counselling destruction. The former class has been but a small one; and I remember that years ago Mr. Cowan and myself almost stood alone in this matter. We had had, unfortunately, to deal with foul brood; we had attempted curative measures, and had succeeded. We were anxious that others should share the knowledge of our methods of treatment, for they were not identical; but from reasons, which from my point of view I will endeavour to explain, the destroyers seem for the moment to have the best of it. Sometimes the word cure has been wrongly used; and that has been denominated a cure which has been only an uncertain means of eradication, always involving severe, and sometimes ruinous, sacrifices. It is my high hope that what I shall have to say presently will deal a deadly blow to this work of queen-killing, comb-burning, and starving, which makes British apiculture handicapped, as it always must be, by the spontaneity of our summer and the uncertainty of our climate, too precarious a matter to permanently hold its way as a means of repetition to the many, or as a means of livelihood to the few.

Salicylic acid has been the substance which has been hitherto constantly used as a remedial agent; but it has had three main difficulties to contend with. First, it is troublesome in application; next, the question of dose has never been properly worked out; and lastly, it has, from a mistaken idea of its insolubility, been associated with borax, which has reduced its curative effect, and made the treatment somewhat dangerous.

1st. It is troublesome in application. It has been recommended to uncap the dead nymphs, removing their bodies when possible, and to spray the combs and frames thoroughly, and next feed with syrup containing salicylic acid. All this must be done regularly and through a considerable period. My observations (for I have been intending to address the Association upon this question for a considerable time), made especially during the last three summers, lead me to believe that the good effects almost all arise from the food, and that the spraying is often a mischief instead of a benefit. 2d. The question of dose has never been worked out. Mr. Cowan recommends  $\frac{1}{2}$  salicylic acid,  $\frac{1}{2}$  borax in a spraying fluid  $\frac{1}{2}$  of the whole; or if the drugs be brought by Troy weight, which they almost certainly would be,  $\frac{1}{2}$  of the whole, while my formula was 25 grains in 8 ozs. water, or 1 in 110; and Mr. Hillart recommended 1 in 200. In addition, spraying is a most uncertain and variable quantity. One man will soak combs and bees by the spray, another will only damp them. I think in any case  $\frac{1}{2}$  too high a proportion. Three weeks since I received a comb in a box, accompanied by a letter, asking what was to be done. (The letter may be seen privately.) Foul brood had broken out, and salicylic acid had been used, but without benefit. The comb contained a large number of dead grubs; and I commenced a microscopic examination, expecting to find the usual living bacilli, and in other cases the spores; but to my bewilderment, the first eight dead larvae contained neither bacillus nor spore, the ninth was filled with the former, and had undoubtedly died of the disease in the normal way. But what of the others? My suspicion was that they had been poisoned by excessive drugging, and writing at once for details, I obtained information which puts the suspicion beyond doubt. Mr. Raitt some years since complained that salicylic acid was a humbug, and gave as one reason that he had used so much that he had killed the grubs, and yet it did not cure. Depend upon it, the order of mind that concludes if 1 oz. of salts will keep off a billion attack for a fortnight,  $\frac{1}{2}$  lb. will keep it off for two months, exists in the bodies of many bee-keepers amongst the humbler classes,

and so the extremely uncertain quantity given by spraying has its dangers, beside which, spraying chills terribly, and takes all pluck out of the bees. Salicylic acid is a poison. I, with others, have said differently, but I eat my humble pie, and acknowledge my error. The French Comité Consultatif d'Hygiène Publique has twice reported against the employment of salicylic acid, even in small quantities, as a preservative agent in food. These reports have been strongly opposed by interested parties; but it has been shown that it has frequently acted as a cumulative poison, and has in several instances proved fatal. (Abridged notice from *l'apiculteur* of this month.)

The borax shall be dismissed with a word. It does nothing but, by making a new compound with the salicylic acid, gives it great solubility. I sing hot spray as I have recommended makes it needless. It adds to the complexity and massiveness of the remedy; and I notice Mr. Cowan, in the last edition of his *Guid-book*, which he most kindly sent me, has substituted Hilbert's for Muth's formula, and so omits the borax. But Mr. Cowan now introduces to us Bertrand's Fumigator. If all bee-keepers were as scientific as Mr. Cowan I should hold even in its being a great service; but it is simply a sullying apparatus in which for every sized hive, and every strength of stock, and every possible number of frames, 150 grains of salicylic acid must be used. The dose seems to have been worked out here with great refinement; although to doubt the 150 grains is but the equivalent of 1 gram named as the quantity by M. Bertrand; but when we call to mind that at 150° C. salicylic melts, and at 220° decomposes; when we remember, too, that in chilling the acid drops in a dew, we can easily see that one operator with the same 150 grains would get twenty times as large a quantity into the hive as another; and to my hope of Bertrand's invention is but slight indeed. The plan, too, of feeding with medicated syrup those attacks that are not but may be attacked, I do not think the best understanding of the case would not recommend, at least I do not now join in the recommendation. A drug is, by its very nature, a poison, and even though only used as a prophylactic, must have its damaging effect. But I must spend no more time in laying a dead line, for such I believe salicylic acid cure will soon be amongst British bee-keepers, but must spend a moment or two with the advocates of destruction.

I am not by any means well acquainted with apicultural literature, and do not know by whom or when the idea of shutting down a hive up to till their honey was consumed, by force putting them into their permanent home was originated. Mr. Simmins gave it as the plan he adopted, but I suppose not as his invention, since I find it originally proposed in Kunt's *Veschehandl. Toz-buch*, published 1872. I could here only say that with our present knowledge, that in a swarm taken from an afflicted hive many at least of the bees are themselves filled with bacilli, we can see that the plan of shutting up is the very worst that could be adopted. The bees that drop, as Mr. Simmins suggests, from exhaustion would not probably be those dying of foul brood, and being confined (the stricken with the sound) are likely to perpetuate the disease. The real benefit arises here not from consuming the honey as I have shown, but from delaying the time of egg-production, and so letting the diseased bees die off before they have a chance of acting as nurses. If this ruinous, and to me cruel, plan were in any way necessary, I should say, upon your diseased stock, cutting out all queen-cells ten days after, and giving from a healthy colony a cell just sealed. When the queen hatches make a swarm of the whole into a skep, and transfer next day to a franchise. The skep is only useful because making the swarm is likely to throw spores into the air. The queen will in eight or nine days begin to lay, and all would most probably go well, much more probably than by the

starving plan. The diseased bees would be dead and gone before any nurse-work commences. All the brood that will hatch is secured, and the queen gets no chance of contamination by constantly putting her abdomen into infected cells. A possible contingency if she be allowed to begin ovipositing in the old and diseased stock. My last point is reached—the method of cure which I suggest.

About three years since Mr. Robert Sproule, an Irish gentleman of culture, with whom I several times had the pleasure of a conversation, mentioned to me that he had used phenol in the treatment of foul brood with a good deal of success. I replied that I would seek opportunities of experimenting, and if I found the result advantageous, I would do as I am always glad to do, mention his name with thanks for the suggestion. The suggestion was, however, not quite novel, but no one appears to have done more than think that phenol was out of the question; bees would not take it. This idea is correct, and I find by a letter received from Mr. Sproule, dated 18th ult., that he with the remedy in his possession, for want of noting the way of giving it, lost a large part of his apiary. Mr. Sproule's plan was to feed with syrup, into which he put a small quantity—how much I do not know—of Calvert's No. 1 Phenol. He says in 1882 he was successful with it, 'but'—I quote from his letter—'unfortunately I requeened all my stocks, save one of black bees, with Ligurians. The disease reappeared, and as the Ligurian bees refuse to take the carbolic syrup, I lost them all by foul brood, save and except the black stock aforesaid.'

'What man has done man can do' was my motto, and I sought opportunities of treating the pest, and up to the close of 1883 had so manipulated six diseased stocks that I felt convinced I had that with proper management a remedy beside which salicylic acid was but vexation of spirit. I imagine that with Mr. Sproule's method I should have failed as he did, as I operated entirely on Ligurians and hybrids. (The former bees are as much in repute with me as they have ever been.) Reference to my writings in the *Country* newspaper ten years since shows that my argument has always been in favour of the remedy being given in the food. We have here a constant quantity; every grub must receive the same amount of nourishment, and if we can find a curative agent and the dose, the difficulty is accomplished. I wrote thus seven years since in speaking of salicylic acid: 'When combs are in a very decomposed condition they may have to be taken away, but I do not believe, rather I have not found, this step to be necessary. It is, in my opinion, far more necessary to remove the store, for supposing the honey to carry no infection, it is at least the means of preventing one remedy being given to the grubs. Remove the store; and the bees themselves become the dispensers of the drug we have provided.'

To place the food bottle with added phenol on the hive will, however, do nothing in the greater number of cases. If honey be coming in the bees will not touch it, but open the stocks, remove the brood comb, and pour from a bottle having a dropping-tube, loosely placed in its neck, the medicated syrup into those cells immediately around and over the brood, and the bees will do us a curative quantity of phenol. The syrup is best poured in by holding the comb at about the inclination of ordinary writing, not by placing it on its side.\* Sometimes it is enough to simply pour the syrup into the back comb, when they will fetch it into the brood-nest as needed, and the disease will disappear. But success comes through failure, and I had to experiment and destroy stocks in experimenting in order

to find the curative dose. The vapour of phenol, the phenol being poured on blotting paper on two occasions, killed all the brood. Last autumn I inoculated a stock and allowed it to get into bad condition. I then inserted a comb of store in the centre of the brood-nest and treated one side. The disease disappeared, but raged, although with abated fury, in the other half. Possessing myself of a skep which might be scented from afar, I divided the combs by transferring into two of my stocks, and after allowing the disease to get ahead, quickly had them perfectly sound again.

Having found that  $\frac{1}{2}$  was refused by the bees altogether; that  $\frac{1}{4}$  might be given constantly to a sound stock without appearing to limit the queen in breeding or touch her health; that  $\frac{1}{8}$  despatched foul brood quickly even while honey was coming in, and that  $\frac{1}{16}$  appeared enough when it was not. I have established these quantities as the correct ones. I then, in the interest of apiculture, requested the British Bee-keepers' Association to provide me with a bad case so that the attention of bee-keepers might be arrested. The colony has been supplied me by the kindness of Mr. Mills, and has been open to visitors, marked by Mr. Hooker, and officially attested. When it arrived on the night of June 21st it contained seven frames, only enough bees to cover two of them, and queen-cell afterwards found to contain foul-broody matter only, scarcely any living brood and a good deal of dead. A casual counting of one of the best frames gave 371 dead larvae on one side. The colour was pronounced. A case such as this would have been utterly hopeless on any plan but the one I am now advocating.

With me queenlessness presents the worst of all difficulties. No grubs, no physis, no cure. Unqueening a foul-broody stock is giving up at once, it is decapitating to cure the headache. I had stipulated that the hive should have a queen, so my difficulty was greater than I had anticipated, and yet the hive is here to-day strong, vigorous, and healthy, and has been so for a week past. No cell has been uncapped, no diseased grub removed by me, my treatment has been giving food and getting that food converted into bees as rapidly as possible. Bear with me in this over-lengthy paper while I explain my procedure.

Seeing early next morning, June 22nd, the utterly disheartened condition of the poor bees, I went to a nucleus, took out a very fine Italian mother just proved as purely fertilised, and putting her under a dome case on a card, placed the card over the frames, the bees came up and seemed to see in her a new hope. I lifted the card, she was welcomed, and the hive was now queened. I waited three days till she was regularly laying, giving them syrup phenolated by 1 in 500, and then took two frames from a stock containing the very comb once used in experimental inoculation to which I previously referred. The combs were ugly, and I wanted to be rid of them. They were full of brood. This step would not have been necessary but from the fact that I required a strong healthy hive by the time of the Congress. The bees were now shut up to four frames, and thus behind the division-board, waiting introduction as the bees multiplied, smelt so badly, the weather being hot, that for comfort of self and bees I was forced to spray with water 200, phenol 1. Every evening the medicated syrup was given. The smell vanished, the bees became active and earnest. The comb with 371 dead larvae on one side was last added, and in six days I could only find five smoken caps in the whole of it. Now and again a grub did take the disease, but quickly perfect immunity was the issue. The brood is now as bright, peppy, and healthy as any I have seen. The hive has not been touched except for manipulation, and yet its bottom board has been kept most perfectly clean by the bees themselves.

Here a caution is needful. Carbolic acid is an impure

\* For tender combs an appliance may be made like a chemist's wash-bottle, by which the combs can have the syrup poured into them while they are in the upright position.

phenol, and is useless.\* It contains crocote and cresols, and bees abhor it. Absolute phenol must be used. It is difficult rather to obtain, and so I have caused some quantities to be done up with directions, lest any should desire to experiment at once. It can be had of Mr. Lyon or Mr. Hollands. My fear is best dealers should profess to supply what is required, and substitute a cheaper for an absolutely pure article; if so, difficulties will arise.

There is much more that I ought to add, especially upon details of treatment, and the philosophy of the curative power of phenol, but fear that I have already greatly wearied my patient hearer's restraints me. Another opportunity may arise in which some omitted points may receive attention; but in the meantime pardon me in saying that I feel proud that I have been so fortunate as to contribute something to the science of the question, while I feel delight in that the worst difficulty of bee-keepers has almost ceased to be a difficulty. I could take an apian beginning of March with every stock diseased, and by May 1, with but very little labour, deliver it up clean and strong, as strong as though the disease had never appeared. These experiments and investigations have cost me much in time, and money, and mental effort; but as they will, I feel assured, be the means of saving to bee-keepers generally thousands annually, I rejoice, and ask them to rejoice with me.

On Saturday, July 26th, an audience, mainly composed of those present on the preceding day, assembled to hear a lecture by Mr. Otto Hehner. The Rev. H. R. Poel having been called to the chair, Mr. Hehner proceeded to read his lecture on

#### ADULTERATION OF HONEY.

From times immemorial the activity of the honey-bee has attracted the attention and received the admiration of man. The industry of the insect, its well-directed ingenuity, the deliciousness of its product, and the marvellous order of its gregarious habit, secured it a unique position in the immensity of animal creation. And although, with the advance of knowledge, we have recognised that there exist in nature many other equally wonderful and far grander instances of vast results produced by the co-operation of individuals insignificant in themselves, that, indeed, a great portion of the surface of our globe owes its present structure to the united efforts of countless numbers of creatures, partly of microscopic dimensions, and that the smallest conceivable living cells are the masters and destroyers of all life; yet, even now, the bee receives as large a share of admiration as ever. And with all our advances and improvements in every department of life, now, as of old, honey and milk are still the embodiment of all that is delicious and desirable in food.

In this age of butter innocent of contact with the cow; of wine devoid of grape-juice; of beer without malt and hops; of coffee-berries made in a mould and not grown on a tree; and, if report can be trusted, of eggs not laid by the hen; can it be wondered at that honey has received a due share of the attention of semi-scientific imitators and improvers of Nature? 'Delicious table-honey,' and 'prepared honey-dew,' made in one of many ways, not in a bee-hive but in a factory, is a common article of commerce; and poor *Apis mellifera* has had notice that its services will no longer be required.

To teach you how to make honey, and to enable you to distinguish your product of manufacture from that of the bee, is the object of this lecture.

There exists a very large and characteristic class of organic substances, mainly products of vegetable life, which consist of the three elements—carbon, hydrogen, and oxygen; and as there are for every one part of hydrogen eight parts of oxygen in these substances—

which is precisely the same proportion in which these two elements unite to form water—the class of matter alluded to is called that of *Carbohydrates*. When direct or diffused sunlight shines upon a green leaf, that leaf is stimulated into activity; it abstracts from the air the gas called carbonic acid, but forthwith restores to the atmosphere the oxygen contained in the carbonic acid and retains the carbon. This, directly or indirectly, unites with the moisture contained in the leaf, and the result is the most important of all carbohydrates—namely, *Starch*. Every four parts of carbon thus combine with five of water. The starch thus formed at first deposits in the leaf-cell in which it took its origin. The circulatory juices of the plant, however, gradually dissolve it and carry it throughout the whole system, either to deposit it again wherever it is wanted, or to transform it into other products. Thus in cereals, like wheat, oat, rice, or maize, the deposition takes place in the seed itself; in the potato, in the tuber; in the sago-palm, in the pith of the tree; the accumulated deposit being intended either as food for the growing germ or as a store for the plant to fall back upon in early spring, when under the influence of light and heat the juices begin to show activity, but when as yet no leaf has made its appearance capable of taking its food from the air. One of the most characteristic distinctions between plants and animals is the power inherent to the former of building up their structure from compounds of great simplicity, such as carbonic acid and ammonia and water, whilst the animal is essentially a destructive creature, breaking up the plant-material into its original simple derivatives. But only when the plant has become green, when its cells have deposited that mysterious substance called *Chlorophyll*, its constructive capacity is established. Plants habitually devoid of chlorophyll, such as the fungi, and some parasites, are essentially animal in their nature; they destroy, but do not construct. Each plant, then, which has green parts, contains starch, formed in the leaf; a potato, paradoxical as it may at first sight appear, does not grow in the soil, but in the leaf of the plant; an ear of wheat or of maize, not on the summit of the stem but in the foliage. The starch thus deposited in one part of the plant or other generally conglomerates in minute granules, more or less rounded, and the shape and size of the granule is invariably characteristic of the plant; a glance through the microscope enables the practised observer to declare that this starch granule is one of the potato, that of wheat, or of sago, with just as much certainty as the unaided eye distinguishes between an apple and a pear, although the substance of both is essentially the same.

Starch, then, is the first and by far the most important of organic substances produced by the plant. From it multitudes of other vegetable products take their rise, constituting the greater portion of all plant structures. In order that this can be done, the starch once formed must be carried about by the sap of the plant into every cell, be it of the root or of the flower. Now as each cell is a delicate membranous bag closed in itself, it follows that solid substances, such as starch, owing to its insolubility in cold water, would, be, cannot circulate through the plant, and somehow or other the work of solution has to be accomplished. This process is best observed in the case of germinating starchy seeds, where comparatively large and compact stores of starch granules pass into solution in a short space of time. If to a considerable bulk of starch paste—such as results by the action of boiling water upon arrowroot or corn flour—a little crushed malt be added, the paste becomes liquid almost instantaneously. A cold infusion of malt acts equally vigorous, and when examined chemically is found to contain a small amount of a substance nearly related in composition to white of egg, called *Diasase*; and it is owing to the presence of this in malt, in all germinating seeds and active plant juices, that the solution of starch

\* Phenylated soap of good quality with plenty of water is the best cleanser of hives and apparatus.

is effected. Of course, in the case of a growing plant we have raw starch, unsoftened by heating, and the process of solution is proportionately slower, but still it is essentially and in its results entirely the same.

The solution thus obtained is devoid of starch; it has become sticky and sweet, and contains two or three dissolved matters, one of a gummy nature called *Dextrine*, and a variety of sugar named *Maltose*.

The animal, appropriating the starch formed and stored by the plant for its food, has also, before it can utilise it, to bring it into solution, and for this purpose its saliva is furnished with a substance analogous to diastase, called *Phyaline*, which acts equally rapidly and powerfully upon starch, especially boiled, the products of its action being also dextrine and maltose.

In an entirely chemical manner this solution of starch can likewise be readily effected, and, as will be seen further on, this chemical action is one of great importance to manufacturers of 'fine prepared table honey.' It consists simply in heating starch with acid, generally sulphuric. But the action is not quite identical. Dextrine and maltose are at first formed; but these, by the continued action of the acid, gradually disappear, their place being taken by a substance called *Dextroglucose*, or fruit sugar, because it is identical with that found in ripe grapes or other fruit. This is also a kind of sugar, but it contains a larger proportion of water than starch or dextrine; namely, for 4 parts of carbon, 6 parts of water.

This product has long been made on a very large manufacturing scale, and is known in the market under a variety of names,—saccharum, brewing sugar, and corn sugar. Its syrupy solution in water is called 'corn syrup.' It readily ferments when brought into contact with yeast, and yields the usual products of fermentation; namely, carbonic acid and alcohol. Hence its use for brewing. The outline of its manufacture is this:—Starch, water, and sulphuric acid, are heated together in a steam-boiler; the fluid thus obtained is mixed with chalk, which neutralises, and to a great extent removes the acid, and the clarified solution is then boiled down, either to syrup form or until the solid sugar remains behind.

But allow me to follow a little further the changes which take place in the plant after its diastatic sap has dissolved the starch. From the solution every minute cell abstracts a portion of the sugar and deposits it in the form of *cellulose*, or woody fibre, which forms the framework—the skeleton, as it were—of every plant. It has chemically exactly the same composition, both qualitatively and quantitatively, as starch. Like this it can readily be converted into fruit or brewing sugar by the action of sulphuric acid. Every one has heard—generally somewhat incredulously—of sugar to be manufactured from old linen rags. This, however, a perfectly feasible proposal, which could readily be carried out if the low price of starch did not render the employment of cellulose for the preparation of this kind of sugar unnecessary and unprofitable.

Another portion of the dissolved starch is changed by the plant into the sugar *par excellence*, cane sugar, which for 4 parts of carbon contains  $5\frac{1}{2}$  of water. In a few plants, as in the sugar-cane, the beet, or the maple, this is the principal product into which the starch is changed, and from these the enormous supply of cane sugar is derived; but all plants form more or less cane sugar, and secrete it by an apparatus connected with every flower, called the *nectary*. Now it is generally supposed that the nectary supplies to the bees visiting it the honey which we take from the hive. This is, however, not the case. The sweetness of most flowers is almost entirely, or in part, due to cane sugar; and honey, as I will show presently, is devoid of cane sugar. The bee abstracts this cane sugar from the flower. It passes through its body, and is there transformed into two other sugars, the one being *dextroglucose*, the identical glucose

which results from the action of sulphuric acid upon starch; the other is called *Levoglucose*, or *Levulose*, a syrupy, exceedingly sweet sugar, of the same percentage composition as dextroglucose. The bee, therefore, must contain some principle allied to diastase which effects this change. This can also readily be brought about by the action of acid upon cane sugar, and a syrup is thus obtained consisting of dextro and levoglucose in equal proportions.

The amount of sugar thus secreted by flowers varies much. One fuchsia flower yields 117 grains of sugar, five-sixths of which are cane sugar; one *Claytonia*, 906 grains, two-thirds of which are cane sugar; each flower of the garden-pea has 153 grains of sugar, almost wholly consisting of one or both of the glucoses; vetch, 902 grains per flower; red clover, the same amount. Now, seeing that each head of clover is made up of about 60 individual flowerets, 100 heads would yield 11·2 grains of sugar, and 62,500 heads would give 1 lb. avoirdupois of 7000 grains. To collect 1 lb. of sugar, therefore, sixty times 62,500 distinct flowers of clover would have to be deprived of their nectar, and 3,750,000 visits would be necessary. But as honey contains on the average only about 70 per cent of sugar, a somewhat less number of visits, namely 2,625,000 would suffice for the production of 1 lb. of honey.

Through the kindness of a great number of members of the British Bee-keepers' Association, and others, I have been placed in possession of very many samples of honey of known derivation,—of apple and fruit blossom, of may, limes, beans, heather, clover, sainfoin, cinquefoil, blackberry, and other honey-yielding flowers. I have very carefully examined them, and found every one to be free from cane sugar. Even when bees were fed upon cane sugar alone, yet the honey stored by them was devoid of that sugar. Honey, therefore, must be regarded in the light of a true secretion, and not as substance merely culled from flowers and stored in the comb.

The bulk of honey, then, consists of the two sugars which I have named, kept in solution by a quantity of water amounting to about one fifth of the total weight. This quantity of water is not quite sufficient to keep one of the sugars—the dextroglucose—permanently in solution, and gradually, therefore, this separates in a crystalline form, honey in consequence becoming in time opaque, and even solid. Genuine honey almost invariably undergoes this physical change; and although there are rare exceptions, a guarantee given with any sample of honey that it will remain permanently clear may be taken as a sure evidence of adulteration, either by the addition of water or of artificial syrup.

The proportion of water in honey is not a merely accidental one. Were more than one fifth part of water present in honey it would, in warm weather and in the normally high temperature obtaining in the bee-hive, be so fluid as to cause the honey to run out of the comb and to undergo fermentation. Water would also gradually evaporate. Were the amount of water smaller than that I have stated, honey would habitually crystallise and solidify in the comb, and in damp weather would attract moisture from the air. In honey, the happy medium just prevails. It neither loses nor appreciably attracts moisture, and in the comb remains perfectly transparent and clear for a considerable length of time.

Thus water, dextroglucose and levoglucose, constitute by far the greater bulk and weight of honey. But the bee carries away from the flower other constituents, less in quantity but by no means in importance, and incorporates them in the honey. Accidentally perhaps, but none the less invariably, a great number of pollen granules find their way into the comb, and these in their turn carry with it the odour and aroma peculiar to each flower. Minute amounts of colouring matters are dissolved from the pollen and give honeys from different flowers the innumerable shades of yellow, green, and

brown with which every bee-keeper is familiar. Thus honey from white clover is practically devoid of colour; that from sainfoin is yellow; from limes, more or less green; from beans, brown; from marshy heaths, almost black. Far greater still is the variety of flavours and odours. Every conceivable aroma, lovely and delicate as that of the flowers themselves—sometimes, I must acknowledge, also repulsive and unpleasant—is met with, and the practised observer can, without much difficulty, conclude from this from what kind of blossom the bulk of any given sample of honey is derived.

More characteristic still is the size and shape of the pollen. Infinite varieties, each characteristic of a particular genus or class of plant, can be seen in honey, and a glance through the microscope is frequently sufficient to ascertain with a great amount of accuracy the name of the plant from which the honey is derived.

From the very variable amount of pollen granules met with in different honeys—some samples which I have examined containing enormous numbers, others but very few—there appears to be a considerable difference in the degree of cleanliness with which bees store the honey. Some flowers yield an infinitely larger number of pollen granules than others, but the importation of the latter to a greater or less extent into the honey itself appears to me to depend mainly upon the bee itself.

There are three classes of manufactured honey: first, honey made from ordinary sugar, and essentially consisting of cane-sugar syrup; second, that obtained by the action of an acid upon cane-sugar, and consisting, as does genuine honey, of water, dextro and levo-glucose; and third, the product of the action of acid upon starch, called corn syrup. I have never met with any samples of the first of these three classes, and I doubt whether any such article can now-a-days be found, although in older works on adulteration their occurrence is asserted. The second kind is also very rare, but yet it exists; but the third, starch syrup, is the main substitute and adulterant used at the present time.

The characteristics of these articles compared with those of pure, natural honey, are as follows:—A solution of pure honey in water, when boiled with one of a salt of copper which has been rendered caustic by the addition of potash, deposits a precipitate of red suboxide of copper, 100 parts of honey thus yielding about 137 parts of precipitate. Neither by the addition of alcohol, nor of lead acetate, nor of barium chloride, should a solution of honey be rendered perceptibly turbid. Subjected to fermentation by the addition of yeast, practically the whole of the saccharine material should be decomposed, and transformed into alcohol and carbonic acid. And lastly, a ten-per-cent solution of pure honey, when examined in an instrument called a polariscope, should have no perceptible action upon polarised light. If anything, it may turn the polarised ray very slightly to the left.

Cane-sugar syrup agrees in its chemical behaviour with real honey, inasmuch as it does not yield precipitates with alcohol, salts of lead, or barium, and is also completely fermentable. It differs essentially from it, inasmuch as it does not give with the alkaline copper solution alluded to a deposit of red suboxide at all, or only a much smaller proportion than that holding good with honey. Its ten-per-cent solution turns the polarised ray of light powerfully to the right.

Cane sugar which has, by treatment with an acid—sulphuric or tartaric been made into dextro and levo-glucose, is practically identical with honey sugar, and as such exhibits precisely the same characters as does genuine honey. Its origin, however, betrays itself by the traces of acid which always remain mixed with it, and which cause precipitates either with lead or barium solutions, or with both.

Corn or starch-syrup, lastly, differs in almost every respect from the genuine product. It throws down

abundant precipitates with lead or barium solutions, often with alcohol; it does not ferment completely, but leaves about one fifth or one sixth of its weight as unfermentable, gummy residue, and, examined by the polariscope, turns the ray of light powerfully to the right.

These few simple tests readily enable us to distinguish these products from each other, and from honey. Examined with the microscope they all are found to be devoid of pollen; and, in consequence, are without the delicate aroma, the bouquet, which is inseparable from the product of the flower and the bee.

By far the most common of these kinds of adulterations is starch sugar, and this for several reasons. The price of starch is lower than that of any other available carbohydrate, and this kind of sugar is, for other and more legitimate purposes, manufactured on a very large scale. Since all restrictions on the preparation of ale or other so-called malt beverages have been done away with, and the tax is levied only on the strength or gravity of the liquor before it is fermented, it is found to be more economical to convert starch of rice or maize into fermentable sugar by means of acid, than by the aid of malt diastase, and the trade in brewing sugar has correspondingly increased. But the main reason is the very close resemblance to genuine honey of syrups made from starch sugar. They do not readily crystallise, and are devoid of the over-powring sweetness of cane sugar. In America, especially, the production of starch sugar has been developed to perfection, and even as substitute and adulterant of cane sugar the article is used to a large extent, although the very low price of cane sugar must militate not a little against adulteration of any kind. As was to be expected, corn syrup is actually most frequently found in honeys imported from America, although Switzerland is striving hard to carry off the 'honour' attached to the production of artificial honey.

Of forty-two samples of honey obtained by purchase from retail dealers, partly by myself, partly by Mr. J. M. Hooker of the Bee-keepers' Association, twenty-six were avowedly English, nine American, four Swiss, two French, and one Transylvanian. Twenty-four of the English samples were undoubtedly genuine, and two (which I have very good reason to believe of American origin, although vended as English) were adulterated with corn syrup. Of the nine American and Californian samples, seven were adulterated, namely, six with corn syrup and one with inverted cane sugar; whilst of the four Swiss samples not one was genuine. The two French and the Transylvanian samples were pure.

The most satisfactory part of these results is the freedom of English honeys from adulteration. As far as my experience goes, there exists no regular English factory of spurious honey; only where the American element asserts itself corn syrup may be expected. As to Swiss honey, I have seen it stated, in corroboration of my results, that every exporter—otherwise manufacturer—of Swiss honey adds to the natural product a more or less considerable quantity of starch syrup, the alleged philanthropic object being to obey the desire of the public for clear and uncrystallisable honey, purchases being credited with the belief that pure and genuine honey is always clear and fluid. In mitigation it is urged, that honey from Switzerland is not sold as 'genuine honey,' but as 'Swiss honey.'

I find that the price is no indication whatever of the genuineness of the article. Some of the 'Swiss table honeys' cost, retail, 1s. 5d. per 1-lb. jar; English honey of perfect purity is to be met with at 5d. and 6d. per lb.

Of course, perfectly pure and genuine American and Swiss honeys do exist. Bees all over the world appear to secrete similar honey, just as I have ascertained, as the result of an extended investigation into the nature and composition of wax, that that product is of perfectly uniform composition, no matter by what kind of bees or in what part of the world it may have been

produced. But seeing that the chances of obtaining pure honey are much greater in the case of English than in some of the foreign supplies which I have named, I cannot but think that lovers of honey would do well to eschew the foreign product until a decided change for the better has taken place in the commercial morality of the vendors, and be content with that gathered from British fields and pastures.

The adoption of anything but the plain name of honey carries to me, after the experience above detailed, the suspicion that the article designated by a name more or less qualified or fanciful is not genuine. Thus I have acquired, and hope to impart it to you, a suspicion against 'honey-dew,' 'table honey,' 'prepared for table use,' or 'finest prepared table honey,' because I have found, that just as good wine needs no bush, so good honey needs no fancy name. These names and qualifications do not convey to the purchaser the simple plain fact that the article is adulterated. They may ease the manufacturers' elastic conscience, as disguised declarations that the honeys so designated are not in the same state as they left the hive. But I think they would not for a minute be held to be valid declarations, required by law, of the mixed nature of these compounds.

Chemistry during the last fifty—or shall I say thirty?—years has made enormous strides. It has enabled us to obtain a fairly clear insight into the working of life-processes, both vegetable and animal, to understand the composition of organic matters, and to trace their thousand-fold changes in living organisms. It has broken down the barriers which not so long ago were considered insurmountable, dividing the living from the dead creation. It has enabled us to make artificially, from the very elements, substances formerly intimately associated with life-action, and almost every day new organic substances are added to the already long list of those which are the result of laboratory work. But so far only chemical compounds of comparative simplicity have been the result, and in not a single case has any complex product, such as is used for food by man or beast, been obtained. Indeed, with all the enormous amount of research and experiment we only stand on the threshold of real knowledge of organic life; we only see the rough outlines of the composition of living things. We know what the bulk of their components is made of, but in the case of food substances it happens that their value, and above all their price, generally stands in no direct relation to their composition. A cargo of manure, or of some metallic ore, possesses a value which bears a direct relation to the percentage of phosphoric acid or of metal which by analysis can be ascertained to be contained in it. A load of oil-cake or other cattle-food generally has both a feeding and a money value, directly proportioned to the amount of oil and of albuminous compounds which can be extracted from them. A water supply depends on quality strictly upon its composition. But the case is vastly different in that of most food materials used by man. Composition, as ascertainable by chemical analysis, goes for very little; *quality*, which is dependent upon circumstances beyond the present ken of the chemist, goes for a great deal. Wine, for instance, consists essentially of dilute alcohol, slightly acid, and more or less coloured. But whilst a good bottle of wine may fetch—and be worth—say five, or ten, or more shillings, I have yet to taste the first sample of artificially coloured and dilute alcohol, slightly acid, which should be worth even a shilling per bottle. A pound of tea has no more food value than a pound of sloe or willow-leaves, but who would pay for the latter, say, three shillings, which the tea is really worth? And so on with almost every article of food or of luxury. The value is not a question of the composition of the bulk of the article, but is regulated by the presence or absence of exceedingly minute amounts of flavouring matters, of which we know little or nothing at all. The

difference between good and bad wine, or tea, or meat, is so small, that the most subtle analysis generally fails to detect it. And as in the case of these articles, so it is with honey. We prize honey, not because it consists of some sugar or other and water, but because it possesses a delicate flavour and aroma which is absent from, and cannot by any means at present known be given to, any artificially made syrup. Were the taste of the public educated for honey in anything like the same degree as it is in for tea, wine, or other articles of every-day consumption, no one would venture to palm off artificial syrups for real honey. As well might a butcher offer his customers leather instead of meat, the composition of both being nearly identical.

It is possible that, as far as mere food value is concerned, the substitute is as good as the original article. Sugar, whether taken in the shape of cane sugar, starch sugar, or honey, produces the same proportion of heat and muscular energy. Butterine or oleomargarine, when burnt or digested, produces no less, if not more heat, than does butter. Yet butter holds its own against its substitutes, partly on account of its delicacy of flavour, and its much more ready digestibility. Some experiments recently made with starch-sugar syrup point towards a similar difference between it and honey, in favour of the natural product. Bees refuse, as long as they are able, to feed upon corn syrup; when driven by sheer necessity to take it, they soon die of diarrhoea. This fact should make us at least pause in giving a definite opinion as to the relative food values of the two products.

There can be no question that the Sale of Food and Drugs Act, at present in force, is as perfectly capable to operate against spurious honey as it is against other articles which are 'not of the substance, nature, and quality demanded.' But yet, as far as I am aware, it has never been put into motion against manufacturers of 'honey.' About 180,000 samples have been analysed by public analysts since the Act is in force, but I have not heard of a single prosecution in the case of spurious honey. It is not the fault of the analysts, who have absolutely nothing to do with the collection and purchase of samples. The growing evil of substituting a manufactured article for the genuine product presses especially heavy against the English producers, because the public seem to prefer honey derived nominally from fragrant alpine herbs, but practically from potatoes and sulphuric acid, or from some mythical Californian bee-farms, to that collected from English hedgerows and meadows. But this evil is not yet recognised by the general public; the taste for honey is not educated; any syrup is eaten as honey, provided it looks transparent and is contained in a neat bottle and boasts of a fine label. As soon as there is a demand for really good, delicately flavoured honey, and the Sale of Food Act is put into operation at the initiative of the public, corn syrup will be a thing of the past.

In order to aid in this desirable education of the public taste I would recommend that, whenever practicable, bee-keepers should state on the labels of the honey they sell from what kind of flower the bulk of the product is derived. Clover honey, lime honey, or heather honey, for instance, are quite as distinct in their characters as are Burgundy, Rhensish, or Moselle wines; but yet, while no one would purchase any wine without distinctly stating the specific variety which he desires, all kinds and sorts of honey are sold without any explanatory designation. Of course, from the nature of the article and its collection it is impossible, in many instances, to state its precise derivation, but whenever practicable this should be done. The British Bee-keepers' Association, which either directly or by means of its country branches has done so much to raise and encourage scientific bee-culture, could readily induce its members in this manner to aid in educating the consumers of honey. When fruit-blossom, lime, or bean honey is met with in com-



mere, perhaps manufacturers of the artificial article will possibly meet them in designating their product starch or cane-sugar honey. There can be no possible objection against the sale of these compounds, if they are only duly acknowledged to be artificial.

Not many months ago farmers had their attention directed by the highest authority towards the advantages of fruit culture and the production of jams and other fruit preserves. In these times of agricultural depression every branch of industry which gives a chance of adding to the annual income must be carefully nursed and cultivated. A period has almost been reached when, in the agriculture of this country at least, these branch industries have risen to an importance greater than the original main occupation. Now is the time to study and to encourage the keeping of bees. With the pecuniary advantages, with the mental pleasure connected with it, I have now nothing to do; others, more qualified than myself, will not fail to present to you this side of the question. But if, by the matter which I have brought before you, I should in any way have contributed towards a largely increased production of English honey, I shall consider the result with the liveliest satisfaction.

[The discussion on the preceding lectures will appear in our next.]

## ADDITIONAL SUBSCRIPTIONS TO THE

## PEEL FUND.

£ s. d.		£ s. d.	
<i>Berkshire.</i>		<i>Surrey.</i>	
M. Whittell . . . .	0 2 6	W. Hollands . . . .	0 2 6
<i>Buckinghamshire.</i>			
Rev. F. S. Schuler . .	2 2 0	W. P. Wenham . . . .	0 2 6
<i>Lincolnshire.</i>			
W. Martin . . . . .	0 10 6	J. Wood . . . . .	0 2 6
<i>Middlesex.</i>		<i>Warwickshire.</i>	
W. Scarr . . . . .	0 5 0	J. Walton . . . . .	0 2 6

## BEE-TEXT ENGAGEMENTS FOR AUGUST.

## SUSSEX BEE-KEEPERS' ASSOCIATION.

Aug. 6, Hailsham: 6th, Bayham Abbey, Frant: 6th, Crawley, Down, and Worth: 8th, Forest Row: 13th, Burgess Hill: 14th, 15th, Tonbridge Wells S. B. K. A. Annual Show: 20th, Cuckfield: 20th, Buxted: 21st, Slindon: 21st, Cross-in-Hand: 27th, Midhurst: 27th, West Grinstead.

## KENT BEE-KEEPERS' ASSOCIATION.

Aug. 5, Brimley Horticultural Show: 7th, St. Mary Cray Horticultural Show: 9th, Knockholt Horticultural Show: 21st, Boughton under Bleam Horticultural Show: 27th, Isle of Thanet Horticultural Society (Margate).

## STAFFORDSHIRE BEE-KEEPERS' ASSOCIATION.

Aug. 4, Shugborough Park: 5th, 6th, Kidsgrove: 7th, Darlaston: 8th, Maer: 12th, 13th, Willenhall: 19th, 20th, Bilston: 27th, 28th, Stone (Staffordshire Agricultural Show).

## DORSETSHIRE BEE-KEEPERS' ASSOCIATION.

Aug. 4, Wimborne: 19th, Yeovil Annual Show: 21st, North Perrott: 23rd, Evershot: 29th, Blandford.

## HEREFORDSHIRE BEE-KEEPERS' ASSOCIATION.

August 7, Colwall: 14th, Eastnor: 21st, Bodenham: 22nd, Penybont: 26th, Bromyard: 28th, Hereford.

## Correspondence.

\* \* \* All Correspondents forwarding Letters for insertion in the Journal, Reports of Associations, Shows, Meetings, Echoes from the Hives, Queries, &c., are requested to direct their communications to 'THE EDITOR of the "British Bee Journal," c/o Messrs. Strangeways & Sons, Tower Street, Upper St. Martin's Lane, W.C.'

## OUR HONEY IMPORTS.

The value of honey imported into the United Kingdom during the month of June, 1884, amounted to 15,387l.—From a private return sent by the Principal of the Statistical Office: H. M. Customs to E. H. Belairs, Wingfield, Christchurch.]

THE BRITISH BEE-KEEPERS' ASSOCIATION  
c. THE BEE-KEEPERS' RECORD.

In the current number of the *Bee-keeper's Record*, I notice severe strictures on the constitution and management of our Central Association. The writer of these opinions that those who assisted in the formation of the B. B. K. A.—myself amongst the number—had not the least conception of the position which British apiculture would one day attain; otherwise, he thinks, we should have drawn up a different constitution. Now so far from this being the case, I, for one, am so well satisfied with the work the Association has done, and is doing still, that in view of the unexampled success which has attended our efforts, I am at a loss to see in what way a better constitution could have been formed.

The day, to which the writer alludes—'when quasi-rival societies shall arise' has not yet dawned, and I trust never will. Can it be that the motto assigned to our Association—*Divide et impera*—is the one by which the writer of this most unjust and bitter article proposes to compass the destruction of the Association, and to raise up in its stead a number of separate and independent associations without any bond of union existing between them? Can this be the work of any but an enemy, bent upon sowing discord amongst the members of a united association?

Surely here a *tu quoque* will strike home with all its force, and we may most justly assign the motto, attributed to ourselves, to the would-be author of confusion and conquest—*Divide et impera!*

So great has been the advance in apiculture under the fostering care of the Parent Association that these so-called 'penny County Societies' have not only been established, but are daily becoming stronger, and the bond of union being maintained, there are few, I think, who will maintain that county areas are too small for carrying out the great work which we all have at heart.

Can the author of this article be really in earnest when he speaks of 'cold looks,' 'hostility,' and even 'intrigue,' being the reward of the earnestness and vigour which have resulted in the success of at least one County Association?

For my own part I am not cognisant of any treatment of any single county society, or individual, that could be designated by terms so

harsh. On the contrary, I believe, without a single exception, these associations and their representatives have ever been treated with the greatest courtesy, consideration, and care, for their truest interests.

Then we are told that the Committee are 'self-elected'! Surely, sir, perversion cannot go further.

Looking to the constitution and rules of our Association, the slander is not worth refutation. Furthermore, it is asserted that the Committee is 'upheld'—whatever that may mean—by a 'property qualification.' And what could be more just, expedient, and beneficial?

If a member cannot afford an annual subscription of 20s. is he likely to be able to afford the expense necessarily attendant upon the duties of the position at which he aims?

If, again, a member cannot support the Association by an annual subscription of 5s., is he in a position to take a leading part in the election of a Committee of management of an association whose interests and duties are most onerous and extensive? But, sir, I need not further encroach upon your space in defence of our highly esteemed Central Association.

That Association speaks for itself in the great, good, and noble work already done, under the fostering hand of our kind-hearted President.

And you, sir, if need be, will know how to deal with attacks of this nature—virulent, and utterly without foundation, though they be.

After all that you, and many others, have done and sacrificed, both in time and means and hard labour, this is your reward! You have, at least, this consolation, that you do not suffer alone.

'It is a good thing to dwell together in unity,' and strife and contention will, in the end, obtain their due reward.—GEORGE RAYNOR, *Hawthigh Rectory, Maldon, July 21st.*

#### CURE OF FOUL BROOD BY MEANS OF CAMPHOR.

I send you a translation of an article on the cure of foul brood by means of camphor, which has appeared in the *Bulletin d'Agriculture de la Suisse Romande*, and was a translation by M. A. Zoubareff from a paper which appeared in the *Travaux de la Société Economique Impériale*, at St. Petersburg. M. Zoubareff says that the author is a bee-keeper of great experience, and as the process is so simple and the cost trifling, I thought it worth sending so that those having this disease could try it for themselves. If really effective in destroying the Bacteria, it will be a great boon to bee-keepers.—THOS. WM. COWAN.

'It is well known that camphor acts as a preservative of clothes and furs against the attacks of the moth. It therefore occurred to me to try the application of this substance to the purification of hives infected by foul brood. One spring I found in my apiary two hives having foul brood, one of which being in an advanced state of the disease, whilst in the other it had just commenced. After having enclosed in rags two pieces of camphor about the size of a small walnut, I placed them on the floor-boards of the diseased hives. After this operation the bees in the first hive got rid of the foul brood themselves and recovered perfectly. The bees in the

second hive left as usual for their work in the fields, but were rather unwilling to enter the hive again. Supposing that the bees could not bear the smell of the camphor, at the end of three days I took it out of the hive, and after three days it was again replaced for three days, and so during a whole month I continued to withdraw and replace it every three days.

'Not feeling certain as to the efficacy of this treatment, I wished to remove the queen from the second hive, but on inspecting it I did not find a vestige of foul brood. Nevertheless, I removed the queen of this colony and gave it some brood from which it reared a new queen. Towards the autumn, it had some splendid combs of brood. As for the first hive which was very sally diseased, the camphor was left in it for two months. The population increased, but no new combs were constructed. Having made a careful inspection I only found foul brood in four cells, and towards the autumn the colony became perfectly healthy. After this experience, I no longer destroy my foul-broody hives, but I give them at once camphor, and to my great satisfaction they become perfectly cured.

'For the winter I kept the second hive from which the queen had been removed, and which had reared a new queen. In the following summer there was no trace of foul brood, and this colony gave me two swarms.

'Being by experience convinced of the curative power of camphor, I have given it this autumn (1883) to all my hives without exception. From all those to whom I have recommended this treatment of foul brood I have had satisfactory reports. A short time ago a scientific gentleman who goes in for bee-keeping thanked me for this advice, saying that of all the hives into which he placed camphor in the month of August not one contained a single foul-broody cell, whereas, on the other hand, several cells of foul brood were found in those not being supplied with camphor.—D. OSSIPOW, *Wladicaucase*, 20 November, 1883.

#### MR. HOGG AND HIS TITLES.

In my rustic abode I have been expecting for some time to find an answer to my query as to the means by which Mr. Hogg obtained the post of purveyor to her Majesty. I will now advance a step farther, and ask whether Mr. Hogg has ever been appointed purveyor to her Majesty, and whether he has the slightest right to the title which he assumes.—RUSTICUS EXPECTANS.

#### TEMPERATURE OF HIVES.

I am very pleased to find this subject is being studied by Mr. Haviland, and will endeavour to answer his questions.

The thermometers I used in making these experiments were the smallest I could procure readily. They are mounted on black enamelled wood mounts, graduated to degrees only, from 25° to 120° Fahr., the figures being very distinctly marked in white. I tested them by a very reliable one to several different temperatures, and found them correct. I cut away as much of the wood as possible, so that they were only 4½ in. long, and very thin and narrow. I made cages for them on the pattern of Raynor's queen-cages. I took pains to get an accurate fit, so as to allow the thermometers to be readily withdrawn, and not have the things too bulky at the same time. I will not trouble your readers with previous trials, which I feared were scarcely reliable: but having first inserted the cages without smoking or disturbing the bees in any way, and afterwards the thermometers, and found all to work satisfactorily, I proceeded to record results as I have given; and in no single instance did I get any hitch or delay in

withdrawing the thermometers to record the temperature, or in any way excite the bees, except in the cases I have given when examining the hives. I cut a slit in the inside quilt to insert the cages, and laid the remaining quilts on top of the cages and thermometers, and in no case did I open the bars to allow the cages to pass down between them; but I found the bees cut away the cells to form a passage around them, but hatched brood very close to the cages throughout the week.

No. 5 hive had two quilts only, as sent from the makers, but I doubled an old stocking over the thermometer to keep it from being affected by external temperature.

A friend has continued the experiments for one month with very similar results to my own. More recently both my friend and myself have found a more even temperature of 93 or 94, but I do not question but that it is kept down to that by fanning at the entrance; now again with low temperature at nights we get as low as 76°. But we must give you more figures later on, when the Editor can afford us space. I find also hives are frequently at a lower temperature the second day after manipulation and artificial excitement than previous to being examined; and although the Editor, in answer to a query, has said he believes I have rather 'overstated the mark,' yet I have proved it is possible to find a hive ten degrees lower after manipulation, and that temperature not to be regained in less than a week.

A friend asks me, What did I start to prove? I answer, 'Nothing,' but simply to record facts. I must confess the record rather upset my preconceived ideas; but never mind, *«Gee nu erloa y hyd!»* it must always be with—AMATEUR EXPERIMENT.

#### INVERTED COMBS IN STOCKS.

Mr. Hewitt, after saying 'if I remember rightly,' attributes to me expressions which I certainly never used. It is, I hope, not my practice to be dogmatic, but rather to test by experiment. I should not have called attention to this trifling matter, but from the somewhat defiant manner in which Mr. Hewitt challenges me upon a false issue. I could have furnished Mr. Hewitt at least sixteen years since with comb the exact counterpart of that which he has just discovered, and which he seems to fancy unique. Before using names with a tone bordering upon asperity, it would be well to be sure of having the right one.—F. CHISHAM, *Avenue House, Acton.*

#### SKEPS CONTRACTING AND EXPANDING.

A curious fact has come under my notice in this parish. A woman fed her bees, which were in a skep, with sugar, in a plate six inches in diameter. This she put on the board, by lifting the skep and replacing it over the plate. When she looked at the hive three months afterwards, the plate had by some means been drawn up an inch or more from the board, and was fastened to the comb above, so that she could pass her hand between the plate and the floor-board. I cannot doubt the fact, which was told me by the woman herself last week; but I am at a loss to account for it, and should be glad to hear any suggestions as to how it was accomplished.—REV. C. G., *Penselown St. John, Bath, July 7th.*

[There is a degree of contractility in skeps. They expand or shrink according to the weather. The incoming of honey brought the combs downward to the plate, which attached itself to them; and on the straw being afterwards expanded, the plate was drawn up off the board.]

\* Truth against all the world.

#### DRY SUGAR FEEDING.

As the season is now to hand for provisioning driven bees, it may be useful to state my experience concerning dry sugar feeding. This spring I had considerable trouble from weak stocks not taking syrup, directly over brood chamber, by way of experiment I made some shallow boxes with a stage at one end; which box or trough held exactly 2 lbs. of sugar. The stage at end was perforated with a 1¼ inch hole, and on the underside I tacked perforated zinc, and thereon inverted a 4-ounce bottle filled with water and corked with a sponge; from thence the bees gathered sufficient moisture for dissolving the sugar. Such was most readily taken so by bees on floor-board behind dummy while the syrup was left to take care of itself, and finally after a fair trial as to which was most freely taken the latter removed.

Since Mr. Simmins has given his dummy dry sugar feeder to the bee world, I have adapted the same, but using small buttons instead of nail for the moveable side, and instead of the American cloth for moisture I have used the top bar as the stage on end of trough and placed the water provision in same manner and find driven bees making full use of same. The moisture can thus be supplied when exhausted or reserved for spring feeding without the special provision of American cloth, which under some circumstances might not be wise to adopt especially in feeding driven bees for winter. I find driven bees in my apiary are making good use of supplies given in the water-provisioned (Simmins's) dummy feeder, and wish to express thanks (with many other beekeepers I have talked to) to Mr. Simmins for the most generous manner he always without reserve gives forth the result of his practical experience.—JOHN H. HOWARD, *Holme, Peterborough.*

#### HONEY DEW.—APHIDES.

In this district we have had some heavy dews for the past month or more, and my opinion is that this vile stuff is not fit for human consumption, as it is proved, I think, beyond a doubt it exudes from these small green flies. I shall deem it a favour if some of our advanced beekeepers would give us their opinion on this subject through the *Journal*. I am also of opinion this stuff ought not to be offered to the public as pure honey; if so, it will bring discredit upon the whole bee-keeping world.—H. KERRIDGE, *Secretary Suffolk B. K. A., Ipswich.*

[In reference to the timely letter of Mr. H. Kerridge, which has come into my hands, I beg to offer a few observations upon the causes of the general dark colour of much of the honey now coming to market. The dryness of the season has greatly favoured the production of the various species of aphids which infest more or less every summer our trees and shrubs. A slight sketch of their history would seem essential to an understanding of the cause. In the autumn eggs are laid by the female aphid (a winged insect), and are then covered over by a mucus which gives them sufficient protection to enable them to stand the winter. So far as is known all the aphides now die. On the return of spring the eggs produce wingless females only, which in from ten to twelve days are of full size, and now within their bodies the microscope can trace interior buds, which enlarge, become small, living aphides (not eggs), which being detached from the parent, commences an independent existence, grow for about the same period as their parents, and then by interior buds produce others, which are emitted at the rate of from four to seven daily. This process goes on for nine or ten generations, so that had they not many enemies, foremost amongst which we find the lady-birds and the ichneumon, each one would produce millions of millions of progeny. At the tenth generation the internal buds do not produce the counter-

part of the parent, but winged males and females. The cycle of their history is completed; the eggs are again laid which are to continue the race in the succeeding summer.

These aphides are each provided with two tubes in communication with each other, and which stand up from the back. These emit a very sweet liquid, and some naturalists are of opinion that their use is to provide nourishment to the weak and newly separated young, but this point cannot be regarded as settled. Ants are extravagantly fond of this secretion, and constantly follow the aphids, touching the tubes with their antennæ, when the ants are at once supplied with the object of their quest. I am disposed to theorise that the aphid feeds almost exclusively upon sugar as furnished by the leaf from the starch it is constantly producing (see 'Honey as Food,' and Mr. Helmer's admirable explanation of this point in his lecture on 'The Adulteration of Honey'), and that the excess of sugar is secreted in order that a sufficient supply of nitrogenous matter may be gathered up by the insect. Be this as it may, the excretion, if not taken by ants, is ejaculated by the insect with considerable force. I have stood beneath trees with my back to the sun, and seen thousands of these tiny drops falling through the air. They usually reach the upper surface of the leaves, which by evaporation they make very adhesive. Unfortunately for bee-keepers, when this adhesive surface is softened by dew or rain, the bees, should other sources of supply be failing, take it in quantity and store it. This aphide honey, or honey-dew, is always dark, and so far as my experience goes, of not pleasant flavour, although I must say, to be fair, that many think differently. It is well to view this substance as the milk (so to speak) of the aphids, and Sir J. Lubbock so regards it when with some humour he speaks of ants 'keeping cows;' but to myself the notion is not appetising, and I think bee-keepers should try and prevent the mingling of aphide honey with that of lighter colour and better quality.

I have just seen a crate of sections in which the upper part contains splendid honey, apparently clover, while the lower looks like Spanish liquorice water. Bees collect honey also from glandular organs, found sometimes on the under sides of leaves. I had last summer an opportunity of watching bees working vigorously upon the common laurel, upon the under sides of each of the leaves of which may be observed by careful scrutiny three or four small depressed patches. These I have cut into many cross sections by a freezing microtome, and find the organ a true secreting gland, which no doubt supplies a type of honey, but of quality of which I can say nothing.—FRANK R. CHESHIRE, *Avenue House, Acton, W.*

## Queries and Replies.

QUERY No. 789.—(E. L. H.)—*Depressed Cells.*—Amongst some sections of honey that I took the other day, I noticed three of them had a round patch about 1 inch in diameter of cells not drawn out as far as the surrounding ones by a quarter of an inch. I do not think that this can have been brood-cells stored with honey, as they appeared too white and clear; also the patch was at one side of the section, and in only one section was there a corresponding patch the other side. I should be greatly obliged to you if you would explain the cause of this to me in the next issue of *Journal*.—A. The depressions of which you speak, we presume, were near the centre, and if they had not contained brood, were evidently intended for that purpose originally, but, guided by circumstances, the bees may have changed their original intention.

QUERY No. 790.—(A BEDFORDSHIRE BEE-KEEPER.)—*Zinc.*—Could you, in your next number of the *Bee*

*Journal*, kindly mention whether there is any objection to zinc being used in bee-feeders? I have seen it stated that the action of zinc upon honey renders it unwholesome for bees. Is this the case? and has it the same effect upon syrup? My feeder-bottles, procured from 'one who ought to know,' have zinc tops, or caps.—A. The action of clean zinc upon honey is small, and very slow, and unworthy of consideration, unless the contact of the two be much prolonged. Zinc would, however, be a very improper substance in which to pack honey in bulk, but syrup made with vinegar in the usual way forms slowly a zincic acetate which would be observably prejudicial were not its quantity so minute. This action may be almost entirely prevented, by making the zinc cover hot and allowing a small quantity of wax to run upon and coat it. Our syrup can, made of zinc, is thus always kept coated within with wax, and all tinned iron forming parts of feeding appliances are in the same manner saved from rust and decay.—F. C.

## NOTICES TO CORRESPONDENTS & INQUIRERS.

DEVONIA.—*Condemned Bees.*—As your poorer neighbours' bees will be gathering honey from the clover for another fortnight; we should advise you not to drive any more until the issue of our next number when we purpose referring fully to the subject. Our columns are full this number.

INQUIRENDO.—1. *Foundation in Sections.*—It is quite unnecessary to put so deep a piece as you say, and the foothold it affords for so many bees causes their weight to break it down, being too thin to bear it; half an inch deep or a triangular piece an inch and a half deep to the point is sufficient to give a start, the separators will keep the combs straight. 2. *Foul-Broody Stock.*—Yes, your treatment has been correct according to ideas prevailing up to the present. But, as you will see by the present number, all is now changed. Keep them breeding as fast as possible, and feed according to Mr. Cheshire's directions.

J. S. B.—Absolutely black bees are now seldom to be found in England. The bees you have forwarded may be considered fair specimens of what are styled 'English black bees.' They are as pure as it is possible to expect, seeing the wide diffusion of foreign blood since the introduction of Ligurians.

S. D. A.—1. To transfer from a box-hive to a bar-frame hive. Cut out the combs, and brush off the bees to the hive in which they are to be located, utilizing as much of the comb as possible. 2. We do not think that Ligurians are more inclined to sting than blacks. The irascibility of bees is mainly dependent on the manner in which they are manipulated.

CHARLES SPRING.—You will find answer to your question under 'Useful Hints.' Be pleased to refer to them. O. W.—As it does not follow because a queen is strong and vigorous the second year, that she will be so the following season, but rather the reverse, it will be advisable to supersede her, and re-queen the hive.

A BEE-KEEPER, *Lanhill.*—The bees forwarded were pure black bees, or as pure as they are ordinarily to be found in this country.

J. ROGERS.—For the purpose designed there is no reason to be urged against the mode of driving suggested; and it is not probable that the bees during the short time they would be confined in the bag would have the opportunity of eating a hole through it.

W. W. BUNTING.—There is no objection to your feeding the swarm with the honey thinned; it might be given through a bottle or in a float-feeder. The feeding should be continuous; let the bees have as much as they can take. The maggots described are the produce of the wax-moth (*Galleria cereana*), not of the moth you have forwarded, which is popularly known as the 'Old Lady Moth.'

**THOMAS FISHER.**—*Death's Head Moth.*—1. The Death's Head Moth (*Acherontia atropos*) is very common in places where the potato is cultivated, and is frequently found feeding on the leaves of that plant. This moth is interesting as being one of those insects which find an entrance into, and plunder, bee-hives, feeding upon the honey; and though it appears to be quite defenceless, it is permitted to ravage the store with impunity. Why this should be so no explanation has yet been given. 2. The irascibility of the hive in question is the result of their innate nature, and is not caused by the vicinity of the surrounding vegetable, though it is not desirable to have these plants crowding upon hives.

**COOKSTOWN.**—1. *Foul Brood.*—Having examined the piece of comb forwarded, we have found that it is infested with foul brood. 2. *Clipping Queen's Wing.*—This is often done by bee-keepers with the purpose of marking the queen, and preventing her flying away when bees are swarming; but trouble frequently arises from her falling to the ground and being lost. To cut the wing of a queen, hold her carefully, and with a sharp pair of embroidery scissors take about one eighth of an inch, or less, off the under hinder wing on one side, or both if preferred. 3. *Separators.*—Separators do not usually rise to the level of the top of sections, but are so cut that if found desirable to add a higher tier of sections, the bees should have a free access thereto.

**R. L. JONES.**—1. *Moving Bees.*—You can move the bees in the winter, when they are not flying. Put a board in front of the door so as to make the exit difficult, and call the attention of those which do come out to their changed position. 2. *Value of Bees.*—We could not value them without seeing them, as so many things go to make or mar the value of bees.

**C. HABBERSHAW, GERRARD.** 1. *Simmins' Dry Sugar Feeder.*—The dry sugar-feeder is, and was represented by Mr. Simmins as essentially stimulative. For inducing brood-rearing at all times when advisable by this feeder, at such times nothing seems better than Porto-Rico; but until further trial Mr. Simmins would not recommend other than the best grade of Demerara which can be given in his feeder for winter stores according to his previous directions. 2. *Black Honey.*

The dark colour is most probably due to the presence of honey-dew. We believe it to be undigestible food for bees, although objectionable to many bee-keepers. 3. *Queenless Stock.*—A stock which swarmed on June 11th, and has now no brood, is, we should say, certainly queenless. Give them a frame of eggs and young brood out of another hive. If queenless, they will raise queen-cells. 4. *Canadian Creeper.*—A leaf and a flower of the plant should have accompanied your question. It is probably a Clematis. Our wild *Clematis vitalba* (Traveller's Joy) grows in the same way as described by you, and flowers profusely; but whether *Vitis*, *Clematis*, or *Ampelopsis*, it may be included in the list of good bee-flowers.

**M. B. K.**—1. The bee sent is a well-marked hybrid. Ligurians are constantly found in black stocks, where they seem to be tolerated. No doubt strange blacks are also found in other hives of blacks, but of course cannot be detected. Bees fraternalise more than is generally supposed. 2. *Driving Bees.*—Brood in skeps has generally all hatched out by the end of August, except in heather countries or when fed. 3. *Prices of Honey.*—Honey of all kinds is so plentiful this year that prices are necessarily low. We cannot give you an exact quotation.

**A BANFESHIRE BEE-KEEPER.**—There is every evidence that the queen is infertile. It will be advisable to supersede her and give the bees another queen, either by purchase or by adding a cast to the hive.

**T. S.**—1. *Hybrid Bees.*—The bee enclosed is a hybrid, about three removes from a Ligurian. 2. *Sugar.*—

The sample of sugar would not be injurious to the bees; but it is not such as we would recommend. We prefer the refined crys-tallised sugar. 3. *Driven Bees.*—(a) Large Pettigrew, three moderate-sized lots; (b) eight-frame bar-frame, two; (c) ordinary-sized skep, two. 4. *Food for Winter.*—As much as you can get the bees to take—say, from 15 to 20 lbs. of sugar to each colony. Give the whole of the frames if done now; if later in the season, six; and winter upon six. 5. *Amount of Syrup in Skeps.*—Only by turning up and examining, unless you can judge by weight, according to the size of the skep. 6. *Thickness of Skep.*—From an inch to an inch and a half.

**J. R.** 1. *Transferring.*—At the date mentioned you might transfer the contents of your skep to a bar-frame, require, and feed up for winter. 2. *Smoking Bees.*—There are so many substances used for smoking bees that it is difficult to determine which may be best. Touchwood is as efficacious as any. Rags dipped in sulphuric we should not advise, as the fumes of the sulphuric act injuriously on the brood.

**A. KING.**—*Transferring from a Box-hive.*—Cut out the combs and brush the bees into the hive into which you desire to place them. You would have great difficulty in driving bees from a box-hive in the same manner as from a skep.

**C. W.**—*Toads.*—These animals are of great service in gables. They do good service by their destruction of insect pests. At the same time there can be little doubt that they destroy many bees. In previous volumes of the *Bee Journal* several instances may be found when bee-keepers, desirous of ascertaining the amount of damage done to hives by toads, have caught and dissected them. In one case (see Vol. V., p. 170) no less than twenty worker bees were found undigested in the maw of a toad, besides an innumerable number of flies and caterpillars. Dr. Butler (*Ferriarum Monachy*, p. 128, edit. 1634) says, 'The toad is by nature so noxious to the bees that while he is about the hive (though he but be under their stool) the bees will not prosper.' He is said also to devour them at the hive.

**J. F. ROSSMAN.** See reply to C. Habbershaw (2), and to H. Kerridge, p. 269.

We have increased the number of the pages of the *Journal* this number; but the extent of the papers by Messrs. Cheshire and Heber has obliged us to postpone the appearance of the 'Echoes' and several other interesting communications, and some Reports of Shows.

**BRITISH BEE-KEEPERS' PRACTICAL NOTE BOOK.** By THOMAS W. COWAN, F.G.S., F.R.M.S., &c. Crown 8vo, boards, 1s.; postage *id.* Indispensable for every Bee-keeper. Published by J. HUCKLE, Kings Langley; may also be obtained of all Hive-dealers.

## CHARLES T. OVERTON,

Past Chief-Expert of the Swiss Bee-Keepers' Association.

## THREE BRIDGES, SUSSEX,

Bees to call attention of all Bee-keepers to his

**NEW STOCK of BEE-KEEPING APPLIANCES for 1884,** and hopes to be favoured with their support.

*Skeps and Boxes, Mobiles, and other Prices, awarded at B. operations, Knightsbridge, Hertsford, and other Shows, for the Best Bee Hives, Bees, Smokers, Syringes, Extractors, Candy Foundations, &c.*

Orders can now be booked for Prime Stocks, and Swarms, of ENGLISH, LIGURIAN and other Foreign Bees, for early spring delivery; also Imported LIGURIAN QUEENS.

### SPECIALTIES.

The 'COWAN HIVE,' and Extractors—Ranchman Smokers, the best in use; Supers; Honey Racks; Candy Foundation, American 2-lb. and 1-lb. Sections; FLAT TOP STRAW HIVES, with hole in top for feeding and supering, 2s. each; Crates of 18 1-lb. Sections for Straw Hives, 5s. each, complete.

Questions on Bees and their Management answered by return of post, 3d. stamps. Send 7d. for *Mobiles* in Bee-keeping, 1s. 6d. for *Cowan's British Bee-keepers' Guide*. Catalogue free on application.

**DR. PINE'S**

**Registered Removable Metal Frame Ends.**

*Prize Medal, F.B.K.A., 1882; and numerous other Prizes.*

**B**y the use of this valuable invention the making of Frames is simplified. No metal runners are required, all systems of frames are rendered interchangeable, and propolization is reduced to a minimum.

Unfortunately, as is the case with all inventions of merit, numerous substitutes are being introduced under the name of 'improvements.' But there is not one of these so-called 'improvements' which does not possess defects from which the original invention is free.

It is, therefore, absolutely necessary when ordering Hives to specify that the Frames are to be fitted with 'DR. PINE'S ENDS,' and with no others. All Hive-makers will supply Hives fitted with them, and generally without extra charge, the small cost being saved in diminished cost of labour.

Price of the Ends, 1s. per doz. or 10s. per gross.

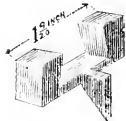

**DR. PINE'S  
Woven Wire Veils.**

*Prize Medal, F.B.K.A., 1879.*

Do not confine the breath, do not obstruct the sight, and cannot be blown against the face or ears.

Price 2s. 6d. each.

**DR. PINE'S BEE-KEEPERS' LOTION**

Is the acknowledged Remedy for Stings, especially for removing the subsequent inflammation. Price 1s. 6d. per bottle.

*The above Inventions may be obtained from*

Messrs. NEIGHBOUR & SONS, Regent St. & Holborn, London; And from all respectable Dealers in Bee-keepers' Requisites.

*Dealers may obtain Wholesale Prices from the Inventor,*  
Mr. F. LYON, 94 Harleyford Road, London, S.E.

**CATALOGUES FREE.**

**Simmins' Hives, Crates, & Sections.**

'FORTRESS HIVES.'

Association 'Standard' Bar-frames, 1s. doz.

J. H. HOWARD, Holme Apiary, PETERBORO'.  
1887

**EDEY & SON'S**

**HUMANE BAR-FRAME HIVES,  
And BEE-KEEPERS' SUPPLIES,**

*Manufactured on Scientific Principles, by an experienced Staff of Joiners, with the aid of Modern Steam-power Machinery.*

**ENGLISH AND FOREIGN BEES AND QUEENS,  
HONEY AND WAX, at Market Prices.**

**SPECIAL OFFER.**—Having purchased Manufacturer's Stock of WOVEN WIRE for VEILS, can offer 20 per cent off list prices for pieces of ten yards. Veils, 2/- each.

Illustrative and Descriptive Catalogue per  
**THOMAS EDEY & SON,  
STEAM JOINERY WORKS, ST. NEOTS.**

**FEDER DUMMIES.**

**O**NE of the best things seen at the R. A. S. E. Show, 1884, was HOLE'S NEW FEEDER DUMMY—two effective appliances in one. For the ease and certainty with which it acts as a fast or slow Feeder and its simplicity, is unequalled. No syrup can run away. No drowned or chilled bees, as with float feeders. No holes to cut in quilts admitting the escape of heat from the Bees, and easy to protect from robbers. The use of such a feeder is calculated to much simplify practical Bee-keeping. Prices, post free, 1s. 6d. and 1s. each. An adaptation of SIMMINS' SUGAR FEEDER, post free 8d., two for 1s. 2d.—all to fit Standard Frame Hives.

**HEREFORDSHIRE SCHOOL OF APICULTURE,  
TARRINGTON, LEDBURY.**

**E. M. HART & CO.,**

**The LONGSTOCK HIVE Manufactory,  
STOCKBRIDGE, HANTS.**

**SPECIALITIES:**

HIVES, complete, from 6s. SECTIONS, V-cut, in 6 sizes. FOUNDATION, Flat, or natural based.

CLARK'S COLD-LEAST SMOKER. 'Far and away the best Smoker.' 3s., post free.

HART'S SIMPLEX FEEDERS. 'The easiest and best to manage.' 1s. 6d. each, 15s. per dozen.

THE 'SWANMORE' SECTION CRATE. 'The most perfect Crate made.' (60)

**The Trade supplied. Price List on application.**

**B**EE VEILS. Improved with Wire Gauze Fronts, or with Silk Brussels Net. Post free 18 Stamps. Address B. DISC, Papworth-Everard, St. Ives, Hants. (59)

**THE DORSETSHIRE BEE-KEEPERS' ASSOCIATION**

WILL HOLD THEIR

**ANNUAL EXHIBITION at YEOVIL on Tuesday, Aug. 19, 1884,**

IN CONNEXION WITH THE

**ANNUAL EXHIBITION OF THE YEOVIL HORTICULTURAL SOCIETY**

When £25 will be offered in Prizes for Honey, Hives, Bee-Furniture, &c.

**SPECIAL PRIZES** will be offered for HONEY exhibited by Residents in SOMERSET, DEVON, and WILTS.

*Schedules of Prizes, Entry Forms, and all other particulars, may be obtained on application from Mr. W. H. DUNMAN, JUN., Hon. Sec. and Treasurer, TROYTOWN, DORCHESTER.*

# THE BRITISH BEE JOURNAL

Communications to the Editor to be addressed 'STRANGEWAYS' PRINTING OFFICE, Tower Street, St. Martin's Lane, w.c.'

[No. 152. VOL. XII.]

AUGUST 15, 1884.

[PUBLISHED FORTNIGHTLY.]

## Editorial, Notices, &c.

### THE CLOSE OF THE SEASON.

Except in those districts which are in the vicinity of heaths, the long-drawn-out honey season is now rapidly approaching to a close. The season has been of a most exceptional character; for, scarcely without a single drawback, from the time when the bees were 'roused by the gleaming warmth' from their long repose of winter till the present day, the weather has been bright, genial, and such as bee-keepers love and desire. The whispers of our 'Echoes,' from England, Scotland, and Ireland, have wafted to us the same pleasant tale. The hum of joy in the hearts of bee-keepers, like that of innumerable bees in the height of summer, is distinctly heard in the land. And now the time is at hand when we may sit down and calmly calculate the profits of this wonderful season—a season without a parallel since that of 1876. The meaning of honey has been so plentiful that we were able in our last 'Useful Hints' to speak in language not often heard by English ears—of 'a hundred tons of honey.' In many a cottage home there will be found cause for rejoicing; the supers and the bottles of honey are plentiful, and it may be that with the proceeds of the honey harvest house-rent may be paid and debts may be cleared off; and bright Hope beckons bee-keepers onward with the prospect of many a future success. In the midst of these pleasant thoughts should not a sense of gratitude to Him 'from Whom all blessings flow' fill our hearts; and shall not, when the time of Harvest Thanksgiving arrives, many a section or glass of honey be seen with the other products of Mother Earth, testifying to the grateful feelings which pervade and swell the hearts of bee-keepers? And, too, may we not, out of the fulness of our gratitude, forward to some cottage hospital or to some town infirmary, a portion of our surplus honey, so that the inmates may have cause to share in our rejoicings?

In whatever direction we cast our eyes we note the progress of bee-keeping. The leadings and the teachings of the past are bearing fruit. Foul brood, that scourge of bee-keepers, is losing its terrors. Through Mr. Cheshire's investigations we have learnt the nature of the disease we have to grapple with; and we have acquired the knowledge of the

antidote. The capability of phenol as a curative of foul brood has been clearly demonstrated, and we have a hope that in the future we shall not hear of the sad ravages which have resulted from this terrible disease.

'Honey as food' in various forms is being more extensively used. We feel much indebted to the Rev. V. H. Moyle for his exertions in this direction. The 'Honey Drops,' manufactured by Messrs. Huntley & Palmer, have proved a great success, and have absorbed a large amount of pure English honey. The same gentleman has also been highly successful in persuading some of his neighbours to manufacture honey drinks; and having had an opportunity of tasting some of these at the International Exhibition, we are able to pronounce them most refreshing beverages. And if some large mineral water manufacturer could be induced to introduce them more fully to the public, another great success would be achieved.

We have also cause to rejoice at the recent venture of Lord Sudeley. This nobleman has of late turned his attention to fruit-farming; 285 acres of arable land near Toddington, in Gloucester shire, have been converted into a garden of fruit trees. And as it is known that the setting of fruits is greatly assisted by the visits of bees to the flowers, a large apiary has been established. A writer in the *Poll Mill Gazette* on the last Bank Holiday paid the farm a visit. Of the apiary he says: 'This I found to consist of 165 hives, under the care of an experienced bee-master, Mr. White, who at once gave a specimen of his skill by taking an artificial swarm and establishing it in a new hive, where, with good luck, it may produce next year 40 or 50 lbs. of honey. It needs more space than is here available to explain the use of "supers," and to describe the beautiful little blocks of untainted honeycomb which are by their instrumentality obtained for the London market. Nor needs to be depicted the extraordinary confidence with which the bee-master treats his bees, fearing no stings and shaking them about as if they were so many stingless and wingless counters. The queen he recognises at a glance. The party got off with one or two stings; those that the bee-master got do not count, as he does not seem to mind them the least.' This experiment of Lord Sudeley's is about the first of its kind in England; and there is no doubt that if proved to be a success it will be largely followed.

The County Associations are on the increase. A beginning has been made in Radnorshire, Denbighshire, and other Welsh counties, and the time will soon arrive when Mr. Peel will see accomplished the desire of his heart in a bee-keepers' Association being established in every county in England. When that time has arrived, he will not, we feel assured, imitate Alexander the Great, who sat down by the shores of the Indian Ocean and wept because there were no more countries for him to conquer; but will look 'over the Border' to Scotland, or across 'the melancholy ocean' to Ireland, knowing that in those countries there is ample scope for the exercise of his untiring energies and his administrative powers.

Nor should we forget to mention that Government has recognised the importance of bee-keeping being taught in Elementary Schools. This matter is in embryo at present, but the possibilities resulting therefrom will doubtless be very important.

The retrospect of the past season is so full of encouragement that all bee-keepers may well take heart and march joyfully forward.

#### IMPORTANT NOTICE.

In order that Candidates competing for Third-Class Certificates during the month of August may have the opportunity of competing for Second and First Class during the present year, it has been resolved to postpone the date for Second Class Examinations from August 16th to Saturday September 6th.

The Examination for First-Class Certificates will be held at South Kensington on Saturday, September 27th, commencing at 11 a.m.

#### UNPROVED CHARGES.

In our last issue we called upon the editor of the *Record* to verify the charges contained in his publication of July 15th; viz. (1), that of mismanagement of the shows on the part of Mr. Huckle; and (2), that the Committee of the British Bee-keepers' Association were self-elected. We have had no reply to our challenge up to the hour of our publication. The *onus probandi* still rests upon him. If the challenge remain unanswered, and the accusations unproved, we hope that in future Mr. Jackson will be more moderate in his charges, and more circumspect in his statements.

#### PHENOL: A CURE FOR FOUL BROOD.

Mr. Cheshire, in his paper read before the bee-keepers at the International Exhibition, gracefully expresses his indebtedness to Mr. Robert Sproule for suggesting to him the use of phenol as a probably successful means for the cure of foul brood. Mr. Sproule, in a communication which appears on p. 284 of the present issue, says 'that whatever credit there is for the suggestion of carbolic acid as a cure for the disease is due to Professor Tiehborne, of the Apothecaries' Hall, Dublin, with whom he had a conversation in October 1881 on the subject.' As the order of the day appears to be, '*Suum cuique*

*tribuito*,' we may be permitted to trace the suggestion of carbolic or phenic acid back to the year 1876. In that year there appeared in the columns of the *Bee Journal* (vol. iv. p. 113) a letter from Captain Danyell, author of *The Italian* [Giotto's] *System of Bee-keeping*, in which he details with considerable minuteness the mode adopted by Signor Brassi and Dr. Dubini, two advanced Italian bee-masters, for the cure of foul brood; and mentions among other curative means the use of 'phenic or carbolic acid.' This letter is referred to by the then editor of the *Bee Journal*, in a subsequent number, as a letter which may be read 'with much advantage.'

In a communication recently received from Mr. Cowan, he says, 'With regard to Mr. Cheshire's treatment of foul brood, I think he has overlooked the fact that it has already been recommended by Vogel and Gravenhorst; and in 1877 Dr. Uech published a book called *Phenol, Thygal und Salicylsäure, als Heilmittel der Brutpest der Bienen*. For various reasons it has not been popular; but you will find in last number of the *Alsace-Lorraine Bee Journal* an article on the cure of foul brood with phenol according to Gravenhorst's method, by F. Vierling, who also calls it "Baecillus" of foul brood.'

#### PHENOLATED SOAP.

Mr. Lyon, who has been associated with Mr. Cheshire in the preparation of the Cheshire Cure for Foul Brood, has forwarded to us a tablet of his 'Phenolated Soap,' which contains fifteen per cent of phenol, and which is specially prepared for disinfecting diseased hives. We have not had an opportunity of trying the effect of this new preparation; but as Mr. Lyon has been very successful in his other assistances to bee-keepers, especially in his lotion for stings, veils, &c., we have reason to hope that this soap may be found serviceable for the purpose for which he has prepared it.

#### DORSETSHIRE BEE-KEEPERS' ASSOCIATION.

This Association will hold its Annual Exhibition at Yeovil on Tuesday, August 19, in connexion with that of the Yeovil Horticultural Society. What Grantham is to the Lincolnshire, Yeovil is to the Dorsetshire. On past occasions there have been large gatherings of bee-keepers, and keen have been the contests for the prizes offered for honey, hives, &c. 'We may well suppose that this (perhaps) too 'refulgent summer' may evoke a greater amount of competition than in any previous year. The exhibition is under the charge of Mr. W. H. Duman, jun., and we may safely predicate that he will put forth every effort to make it a success.

#### CONDEMNED BEES AND HOW TO MAKE THE BEST OF THEM.

Condemned bees when properly treated are profitable and afford a cheap and ready means, in the hands of careful bee-keepers, of increasing their apiaries. But as too often treated they only lead to disappointment from their liability to spring dwindling.



To discover the cause we have only to consider the conditions under which they are obtained. The owners of skeps naturally do not have their bees taken until the honey harvest is over in their neighbourhood, and the bees, knowing it, have commenced to prepare for the winter. Breeding is almost at an end, the last batch of eggs has been hatched and been sealed, the brood-nest has been contracted and the hive begun to be made snug for the winter. Then comes the 'advanced bee-keeper' and upsets the whole arrangement. He drives the bees, and leaves the sealed brood in the combs to be destroyed with them. The skep owners are, as a rule, too jealous to allow the combs to be cut, or any part of them removed. They look with suspicion upon any one wishing to drive their bees for them, and cannot understand what use a lot of bees can be to any one. They have a suspicion that there is something behind, which is concealed from them, and that they are going to be 'beested'; and so it is very seldom that we can secure the sealed brood, much as it grieves us to leave it behind, to be broken up with the combs. Thus most of the bees which are driven are comparatively old, and have done their share of the work. These partially worn-out bees are then put into, sometimes, empty hives, or into hives furnished with comb-foundation, and called upon to set to work again, to build new combs or draw out the foundation, to rear a fresh lot of brood, and to store and seal over the supplies for the winter. What wonder is it then when the spring arrives they have so little vitality left; that they die by thousands under the exhaustion of brood-rearing and pollen-gathering?

The treatment of condemned bees should, therefore, commence before they are obtained, by getting as many combs as will be required *built and stored* by our own bees in readiness for them. By removing the outside combs as soon as sealed, giving sheets of foundation in the middle of the brood-nest and by liberal feeding, one or two stocks can get sufficient combs ready to supply many lots of condemned bees. Not a day should be lost before commencing this preparation.

A celebrated recipe for jugged hare commences: 'First catch your hare,' and perhaps before giving directions for the treatment of the condemned bees, we ought to say a few words about finding them. In the immediate vicinity of towns, in the suburbs of which are sure to be one or two experienced bee-keepers who regularly take bees for cottagers, few bees can be got, being all bespoken, and so we shall do well to extend our search into the remote country places far removed from a railway station or town if we want many lots. Keep a sharp look-out for bees on the wing, and notice their flight. If rapid, they are going from the hive; if heavy, they are going home, and by following the line and inquiring at the nearest cottage we may discover a few skeps. A little diplomacy is necessary in dealing with the owners. The first idea, if they have never had their bees driven for them, is that they will be in a worse position than if they 'put them down.' In many cases a bad impression has been left by some one in former years having bungled over the job, or by robbing having been set up. This is not unusual. Generally, however, the offer of 6d. or 1s. per stock for the bees, which dead would be worthless, goes a long way to overcome scruples. The search for bees had better take place on one day and an appointment made to come again to drive them. The operation of driving bees as witnessed at a show seems so simple that novices feel that they have only to go to the skep and proceed as they have seen the expert act and the bees are driven; but, in practice, many difficulties arise which can only be overcome by cool judgment and skill. In some cases the bees are found clustered outside the skep, and so spiteful that they attack before one has the opportunity of administering the regulation puff of smoke. In others the skep when turned up is only partly filled with combs,

and the bees will not obey the drum of the driver drum he never so wisely: this is especially the case when the stock is queenless, which is generally, but not always, indicated by the number of drones remaining.

Then, again, the hives employed at shows are furnished with old combs, which will not easily break down, and are built nice and straight, while in practice we have to deal with swarms and casts with tender or crooked combs; and the extraordinary receptacles into which the swarms have been put for want of hives are wonderful, and would decidedly puzzle a novice to get the bees out. Among them are to be found large flowerpots, bushel baskets, old pitchers, chimney-pots, &c., none of which allow the receiving skeps to be fixed nor the combs to be properly jarred.

The result of many years' experience of taking bees is that driving is not only a great waste of time, but leads to great robbing, setting the whole of the bees within flight in an uproar.

By the method mentioned later on, bees may be taken in one-third the time and with far less danger of setting up robbing. Moreover, you can get bees out of all kinds of awkward receptacles, which would be impossible to drive.

We will suppose that the preliminary journey has been taken and the promise of several lots in various places has been obtained. The time for taking them has arrived, and we are starting on the journey. It is better not to trust to being able to borrow anything, but to be prepared for all contingencies. If we intend to drive the bees we ought to take sufficient empty skeps to drive each lot into, and leave it on the stand until the evening for the foragers to join. We may sometimes find some empty skeps which we can borrow, but not always.

The illustration of driving in *Modern Bee-keeping* does not by any means show the best method. By putting the skep in a pail one cannot drum the crown of it, which is most necessary to be done to get the bees to run, especially towards the last. Mr. Abbott showed, some years ago, an admirable stand made after the fashion of a three-legged folding camp-stool, but four feet high and without the canvas seat. The skep is placed between the tops of the three sticks; it can be arranged at any angle and the hands can reach every part. A very good copy may be made with three broom-sticks pointed at the lower ends, confined by an iron ring round the middle and with ropes at the feet to prevent opening too far; with this tool we do not need to borrow either pail or table. Plenty of shovels must be taken, as some are sure to get lost among the long grass, a pair of two of driving-irons, made of stout wire shaped like builders' 'dog-irons,' a coil and snoker, a few elastic bands to put round the bottoms of the trousers will add greatly to comfort when standing among grass, on which some bees will be sure to fall and crawl. Plenty of canvas, that known as paper-hangers' canvas is cheap and open, and string to tie down the bees when obtained, must also be provided.

If many lots are to be driven in one day, a horse and trap are essential to carry the apparatus, and as empty skeps will stow one in the other in little compass, while full ones take a lot of room, it is better to carry boxes to put the bees in; these may be readily made out of lobster or salmon boxes from a grocer's. Put a partition across the middle, tack some canvas on it so as to cover each of the two boxes thus formed, to be fastened down by laths and french nails when the bees are in. Each lobster-box may thus contain four lots, two being united on each side of the partition.

On reaching the first place where we are to drive, the first thing to do is to smoke all, and to close all the entrances with a wisp of grass, whether to be taken or not. Get the owner to point out which are to be taken, and ascertain the history of each, proceed to mark them by putting stones on the boards, put one for a stock, two for

a swarm, three for a cast, and four for a virgin swarm; you then know the age of all the queens, and can pinch the old ones when uniting. Now proceed to drive, if you prefer that method, as directed in bee-hooks and as shown at shows. But the quickest and best way is the following:—Ask the skep owner for several large pans, or washing tubs or troughs, and some sacks, these are always at hand. Give more smoke, and take the first hive from its stand, lump it on the ground on its side, the flat way of the combs; they will all break down (and broken combs bleed far less than cut ones): do not let the combs fall out of the skep, replace the skep on its stand crown down, lift out the combs one by one, and rapidly brush off the bees with a wing or a wisp of grass back into their own skep. Put the cleared combs into a pan and cover with a sack. When one skep is empty turn it right way up on its stand on two or three stones and go to the next. As each pan is filled carry it into the house, or wherever you are to put it. By proceeding thus, you may take a skep in five or six minutes, and get the job over before the robbers get to know of it; while, by driving, the average time, taking one with another, is at least twenty minutes, and by the time three or four lots are done the robbers become so troublesome that more get in than you drive out. If you want to find the queen you may generally catch sight of her as you brush off the bees, but if you do not you may search among them for her, or leave her until you get home, and find her at your leisure. Before leaving each place release the bees which you closed in. Arrange your route so that you take those nearest home first. At the last place you visit, wait, after taking out the combs, until the bees are clustered in the skeps, hastening the loiterers by a little smoke, then take one skep, put it on the ground mouth up, put another on it mouth to mouth, lift both together and give them a good bump. Have your box ready with the canvas turned back and before the bees have recovered from their surprise, pour the whole lot into the box, turn the canvas on and nail down. If you like to go to the expense, a hinged lid of perforated zinc is more convenient and fastened down in less time than the canvas. Return over the ground you took going, collecting the bees you have taken. If you drive, the driven bees must be put upon the old stands until your return, or the flying bees will enter other hives and cause great disturbance. In bringing the bees home stand the boxes on their sides so that they cluster on the top side, not on the canvas, or zinc, or they may get smothered. By the plan just described, far less luggage is required. No skeps, or stand, or skewers or canvas. Simply the boxes prepared with their canvas or lids, and which stow easily in a trap. If you have to take thirty or forty in a day, it is no joke to have to take as many skeps with you, indeed to take twenty by driving is a hard day's work, while ten or twelve lobster boxes sufficient to hold at least forty lots can be stowed in a roomy trap.

It is as well to keep separate in the boxes as many lots which you know to have young queens, as you will want to make new stocks; those with old queens may be united two and two. When you get home find and destroy the surviving old queen, and unite another lot with a young queen to the whole, thus making three into one.

On returning home arrange your hives, keeping the condemned bees in a cool place until ready to live them. Each three lots may have eight or nine frames of comb, five or six being stored, and three built, but empty. If you can spare a comb of brood (without bees) all the better. Put the three empty combs in the middle of the hive and feed gently for about a fortnight, so that some brood may be raised to replace that left behind in the skeps. Then if the five stored combs do not appear to have sufficient food within for the winter give a few pounds rapidly. Give your bees just as you would a swarm, after picking out the queens you do not want, and in the evening.

*Difficulties.*—These will be found generally to be,—1, The bees very spiteful. This is often the case on a hot day when no honey is coming in. The only remedy is courage, a veil, and disregard of stings on the hands. When you have once got them well smoked they will soon become calm. If many bees are clustered outside the hive you are to take, a slight sprinkle with water followed by smoke, will get them in. 2, Bees refusing to run. This is often the case with queenless stocks; and also with casts which have not filled the hive with comb. Unless the combs come quite up to the edge of the hive the bees will hang between them and the hive side. The remedy is short and severe, a bump as described above. Robbers are generally very troublesome. They may be kept under by the plan of closing all the hives, even those which are not to be taken; and by the quick plan all is over before they find out there is any honey about. Of course great care is to be taken in covering the combs up with sacks and shutting the door of wherever they are put. After having condemned bees they require much attention while being fed up. If you do not give ready-stored combs as recommended, they will often in the most perverse manner build out one or two sheets of foundation and thicken the combs out with syrup until they break down, while neglecting other sheets. They must be constantly examined, and by turning the combs about, cutting off bulges, and putting that side against the hive-side get them to build straight. A vast deal of trouble is saved by giving them ready-built combs. The less work they do the better they will come out in the spring, and the more profitable they will be.

Of course you will not neglect to explain the advantages of the driving or cutting-out system over the smotheration system, and endeavour to induce the cottagers to take their bees alive another year.

#### QUEEN AND EGGS CONTAINING BACILLUS ALVEI—FOUL BROOD (?)

I snatch a few moments just before the *British Bee Journal* goes to press to give a necessarily most hurried account of my last discovery rather than wait for the next issue. In my paper theoretic grounds were given seeming to show that probably the queen, and even the eggs, might be infected, and that foul brood (?) might be communicated by heredity, as in the case of the disease called pebrine.

Statements had been made to me of the singular behaviour of some infected stocks, which, although weak and decreasing, seemed ever bent on the building of queen-cells, and that these same stocks sometimes also were earnest in raising drones. Two or three similar instances had come directly under my own observation, and so soon as I made the important discovery that adult bees were sufferers as well as the larvae, it struck me that in all probability the explanation of the singular behaviour referred to was that the bees knowing that the queen was defective were endeavouring to replace her, but that her defects constantly prevented their efforts from being successful. It was to me remarkable that only two or three days before the Congress, after my paper was in print, but before its contents had been at all made public, Mr. H. F. Hart, of Stockbridge, wrote to me stating that he had observed a hive in which the disease appeared to strike some of the larvae immediately after hatching, and that the bees built queen-cells. He then showed very keen insight by suggesting that it seemed to him to point to disease in the queen. At the Congress I heard more of the case, and felt convinced that the queen was actually in-

fect. Mr. Hart, with much kindness, agreed to secure her, if possible, and forward her to me. She was twenty-five miles from his apiary, but he took the journey, and she with two others reached me this morning. Mr. Hart will, I hope, feel compensation to some extent for his considerable labour in seeing how very materially he has helped the inquiry. Finding this queen as nearly as possible dead at her arrival, I forthwith commenced a careful dissection under my Stephenson's binocular dissecting microscope; the only form of instrument really equal to very minute examinations. Having opened the abdomen and removed the left air-sac, which was very much above the average size—this I have found a constant indication of the presence of bacillus—I came upon the ovary and felt certain at once, from its appearance, that I should find the 'missing-link,' as Mr. Hart had called it. The ovary, of which I have on previous occasions removed many dozens, was in this instance abnormally yellow and extremely soft, so that it was very difficult to detach it from the tracheae without tearing. I separated an ovarian tube and placed it under a second microscope (using 600 diameters), and at once, to my extreme gratification, four or five bacilli were seen swimming along with a lazy sort of progression. Detaching now a half-developed egg, and exercising great care to eliminate every possible source of accidental contamination, I placed the egg, with a trace of water, upon a glass slip and crushed it out flat with a thin cover, and in a few minutes I had counted no less than nine bacilli.

The right ovary was very nearly free from disease. During a prolonged search I found two or three bacilli only. All this is extremely interesting, as showing that this bacillus disease, like some attacking the human subject, may take both an acute and a chronic form, and may also settle in some special organ or part of an organ, as bacillus tuberculosis may attack one lung and destroy it and leave the other many years intact.

All will, I hope, forgive my esteeming myself fortunate in having thus been able to make out the only points I had to leave undetermined on the 25th of July last. Then I had found the disease in young larvae and those fully fed, in chrysalids in all stages, in drones, in workers just gnawing out of the cell, in young nurses and in old worn-out bees, and now in a queen and eggs unladen. Bacillus alvei is then a disease affecting all and every condition of beehood. Can it continue to be called foul-brood? To say the queen is suffering from foul-brood would be as illogical and ridiculous as talking of tooth-ache in the liver or rheumatism in a wooden leg. Surely our better educated bee-keepers will usually name it 'bacillus,' and when speaking carefully 'Bacillus alvei,' while those less instructed will by degrees learn the desirability of dropping the old and utterly unsuitable term in favour of the one I give, which will with a little practice be no more difficult of pronunciation than its predecessor.

To-day I have been with Mr. Watson Cheyne in the Biological Laboratory, South Kensington, and there we have started some experiments, of which more will have to be said hereafter; but meanwhile I must add that another attempt at curing the disease, in which every possible difficulty has been heaped together, is progressing wonderfully. Bacillus alvei is now understood, and its method of treatment made so easy that he who suffers from it badly will in the near future rather deserve censure than pity. Some, sad over losses and rampant disease, with Job's comforters calling to them to burn their hives, and burn their combs, and kill their queens, and start anew, will, I trust, soon be thankful and cheerful in learning that my method will save everything, with the sole exception arising from the infection of the queen.

In any case in which this may be suspected, and the queen replaced by a second, the removed one would be a treasure to me for dissection purposes.

One caution is needed. Let no one suppose that his is a bad case, and therefore stronger doses than those I have advised are required. The heavy outlay falling upon me for past experiments and investigations will, I trust, yield good interest to bee-keepers, but of those yet to be made I hope to have the burden somewhat lightened by a small royalty I have arranged to receive upon each bottle of my remedy.—FRANK R. CHESHIRE, Avenue House, Acton, W.

#### A REQUEST.

Mr. Cheshire, in examining the abnormal bees known often as 'black bees' or 'black robbers,' has discovered a peculiarity which leads him to earnestly desire other specimens. He therefore begs that any bee-keepers possessing such will favour him and apicultural science by kindly forwarding a few (accompanied by some short statement of the facts of the case if possible) to Avenue House, Acton, W.

#### AUTUMN FEEDING.

Bee-keepers will now be considering the best way to supply their bees with the necessary stores for winter. Each will have to study his own locality, and consider the kind of bees he has, when he may decide whether the preliminary process of stimulation is necessary or not.

Without doubt, our ultimate object is that our bees may come out strong the following spring, and be ready for every opportunity. How best to obtain this desirable end it will now be my endeavour to explain.

First and foremost, it must be remembered that bees should never find themselves poor. Once let them remain short of food, particularly in early spring, they will not recover themselves, or even come up to other stocks that may have started weaker in point of numbers, but with more than sufficient stores for present use. It must be our endeavour, then, to keep all stocks well supplied with food, especially while budding up during treacherous weather. By having them well supplied, I do not simply mean that the feeder is to be kept going, but what is even more important for ensuring a good start, is that we do not permit the old sealed stores to be used up until the latter part of April. Thus only can we stand independent of the usual changeable weather experienced during the spring months. For while stocks not properly stored (and there are many who, from false ideas of economy, continue to have them so) will go backwards, removing much of their brood during a cold spell, those having a good proportion of sealed stores, progress most favourably, frequently requiring additional combs, or foundation when too cold to think of opening those less-favoured stocks.

The prosperity of our colonies therefore depends principally upon the manner in which they are prepared in autumn. Some bee-keepers consider 12 lbs., or even less, of sugar made into syrup sufficient to carry any stock of bees through the winter. That quantity is, perhaps, just sufficient for a strong colony until they begin to move in spring, but extensive experience has shown me the folly of endeavouring to carry bees through the most critical time with a bare allowance, when frequently the feeder is quite neglected, even should it be in use. And, too, we find it is the advocates of that 'penny-wise and pound-foolish' policy who cry out loudly, saying bees are suffering severely when

\* A depression in one compound eye, or in the thorax (tergum), or in the fifth abdominal segment, is an indication of bacilli being present.

a cold wave occurs, though it will seldom last more than ten days.

Every fairly strong hive should, at the end of September, have a at least six standard combs, two-thirds sealed over, when little further attention will be required until towards the middle of the following March, but, from about the turn of days until active stimulation begins, those rich in stores will be breeding slowly at the heart of the cluster, and when once aroused at the time pollen abounds, and feeding begins in earnest, the results are simply marvellous. A correspondent lately stated that by June 1st he had his bees on six combs of brood; but let bee-keepers bear this in mind, that unless they can obtain at least that number of combs full of brood by the middle of April, bee-keeping will not be a success with them year after year.

Much stress has been laid upon stimulative feeding in autumn; and where bees will not continue to breed, they must certainly be induced by slow feeding, to continue the production of young bees until well into September. But with Ligurian bees the process is seldom necessary. After July, when in most districts blacks are giving up brood-rearing, Ligurians will be bringing in more than enough to continue, and in many instances would crowd out the queen if the extractor is not used.

Of course, where heather abounds the extractor is useless for removing the honey obtained from that source, but if the brood-combs are reduced to six or seven beforehand, the bulk of the honey may be obtained in sections, and the stock-combs will not be found like slabs of marble, with little or no brood, as is too frequently the case where the usual number of brood-frames is allowed; bees being so unwilling to store outside the brood-chamber late in the year, and can only be induced to do so when crowded into the smallest desirable space.

In the latter half of September, all colonies should have their surplus combs removed, and then be fed their winter stores as fast as they will take it. No feeding should be done after the end of that month. How about driven bees then? some will say. My answer is this: The true secret of making driven bees pay is to see that all combs needed for them be stored beforehand, and that (with one exception) they be allowed to do *absolutely nothing* after being hived, putting not less than three lots into each set of prepared combs. Finding their combs so well prepared, they will raise just about enough young bees to consume what syrup may remain uncapped. Let them be closed down for winter, and he kept quite alone, as also all other colonies until the following March, unless anything unforeseen should occur.

As to feeders, there are so many offered to the public at reasonable prices, that the best advice I can give to those who require them is that they obtain the catalogues of the various dealers, and select therefrom such as appear to be effective, but at the same time economical, and not forgetting that any float, or similar fast feeder, can also be made to answer the purpose of a slow feeder, if one will place in it only that quantity required by each colony daily.—SAMUEL SIMMONS.

#### BEE-KEEPING GOSSIP.

'Mel' sapit omnia.

Well! bee-keeping is progressing rapidly. The black patches on our map are getting beautifully less, thanks to the energy of 'The Archbishop of Bee-keepers' and his coadjutors. Salop is given new life, and North Wales is on a blaze, having caught the enthusiasm. Surely Westmoreland cannot long be out in the cold with 'Windermere' to stir them up.

There is progress of the right sort in the direction of the Government, but that to be lasting must be con-

tinually kept pegging at, or, amidst the wild scream of party politics, it will get pigeon-holed. I have lived a good slice of my short life in large towns, and know something of the opportunities the town lads have over the rural; but I live now in a rural district amongst a class wholly agricultural, and say emphatically bee-keeping, gardening, agriculture, &c., ought to be taught in the rural schools, and in face of the many special subjects taught in the town schools I cannot see how it can be justly denied.

But next to organizing systematic bee-culture, that of finding outlets for bee-produce stands prominent; and Cornwall, who is always proud of her sons, may well be proud of such a son as the Rev. V. H. Moyle. He leaves no stone unturned in the matter. Messrs. Huntley and Palmer have usually to spend large sums to introduce a new variety of cake or biscuit to the public, but 'Honey Drops' were so advertised through bee-keepers that they were inquired for at first faster than they could turn them out.

And then as to drinks. What a happy thought to bring them to the Conference, and give Mr. Hehner the chance of drinking 'Success to the British Bee-keepers' Association' in a sparkling cup that 'cheers but not inebriates,' and then giving a drink round so that all could try it! And Mr. Moyle intends trying to get every prominent mineral-water manufacturer in the kingdom to make these drinks.

How much we are indebted to Mr. Cheshire for going into the question of foul brood so thoroughly! It is the work of a master hand. Science is rightly defined 'true practice,' and here we have it all carried out on true scientific lines, and cleared up beyond controversy. But there are a few passages about Ligurians I should like to note, but must make it a pleasure deferred.

Amongst all the other Conferences at the Heatheries, what a good idea to have a Conference of Bee-keepers! and how nice to meet so many that one seldom sees, but often hears about, but were there brought together by a common interest, and that so patriotic.

It was really a treat to hear Mr. Hehner so eloquent with our ponderous language, and he a foreigner; but he is quite one of ourselves, and lacks not a word for expression.

It occurred to me that the B. B. K. A.'s exhibition, spite of disparaging criticisms, is really unique. It is complete in itself, has a good position, especially considering its character and the value of space, and, thanks to the various dealers and Messrs. Moyle and Cowan, every branch is represented.

I popped in several times on Saturday to have a look, and what a treat it was to see the Rev. J. Lawson Sisson in front of the Observatory hive, with a crowd around him for hours, expatiating on the wonders of a bee-hive, and how happy he seemed at it! But there, 'A prophet hath honour save. . . .'

The county representatives managed to get through the new 'rules of affiliation' on Saturday after the Conference. They are very good as now amended, but the great pity is that so few counties seem to care about being represented. True, I don't see how many Associations could afford to pay the expenses of one or two representatives to London quarterly 'for a spree;' but then other means could be devised, if sought, by finding some one living in or near London, or by proxy, or many other ways. But Mr. Peel is hopeful, and says it will all come in good time.

For myself, I was glad to get my nose off the mill, and much enjoyed mingling for a few hours with so many 'fathers and stalwart young men' amongst bee-keepers. I wonder if 'Platelay' was at the Conference. Anyhow, unknown to most, but nevertheless there, was — AMATEUR EXPERT.

## ASSOCIATIONS.

## BRITISH BEE-KEEPERS' ASSOCIATION.

A meeting of the British Bee-keepers' Association, at which several members of County Associations were present by invitation, was held at  $\frac{3}{4}$  p.m. on Saturday, July 26th, in the Council Chamber of the Royal Horticultural Society at the International Health Exhibition, South Kensington. The members of the Committee attending were—the Rev. H. R. Peal, the Hon. and Rev. Henry Bligh, the Rev. F. S. Selator, Mr. Hooker, and Mr. Glennie; while the following gentlemen represented County Associations:—Mr. J. P. Sambels and the Rev. A. Roberts (Herts); Mr. F. H. Lemare (Surrey); the Rev. Mr. Mitchell (Bucks); the Rev. V. H. Moyle (Berks); the Rev. W. E. Burkill (Wilts); Mr. W. H. Dunman (Dorsetshire); Mr. A. H. Martin (Worcestershire); Mr. W. N. Griffin (Devonshire); and Mr. Huckle, Secretary of the B. B. K. A. The meeting was convened for the special purpose of discussing certain conditions and privileges of affiliation for County Associations affiliated to the British Bee-keepers' Association.

The Rev. H. R. Peal having taken the chair, Mr. Huckle (Secretary) read the minutes, which were confirmed.

The Chairman stated that as the matters to be discussed affected principally the County Associations, he thought the delegates present from those bodies should be allowed to vote among themselves the projected Rules, which would be submitted for their consideration. He therefore moved a resolution in accordance therewith, which having been seconded by the Hon. and Rev. H. Bligh, was carried unanimously.

The Chairman said he believed there was a general feeling that the conditions they were about to deliberate upon, which were passed as long ago as July 1880, should be reconsidered, and to a certain extent amended. The Committee had recently received communications from the secretaries of county organizations commenting on them, some of which he would read.

The Gloucestershire and the Derbyshire Bee-keepers' Associations, in their letters dated May 1884, thoroughly approved of the Rules; whilst the Isle of Wight, Cambridge, and Cheshire auxiliaries took exception to some of them.

The Conditions of Affiliation Nos. 1 to 4 inclusive having been considered and approved at a previous meeting, the discussion commenced with Rule 5, which, on the motion of the Rev. W. E. Burkill, seconded by the Rev. V. H. Moyle, was agreed to as follows: 'The Balance Sheet (specimens of which and of a title-page can be had of the Secretary of the Central Association) should contain a note stating the gross amount of liabilities (if any) at the time of balancing the accounts.'

In reply to Mr. Dunman, the Chairman stated that no local Association could be affiliated to the parent body unless it conformed to the conditions of affiliation.

Mr. W. N. Griffin proposed, and the Rev. V. H. Moyle seconded, the adoption of Rule 6, which was carried unanimously as follows:—'That in order to secure uniformity, the size should be ordinary 8vo., and that the length of line should be similar to the Report of the Central Association. The sequence of subjects in the Report should be as follows: 1, List of Committee and Officers; 2, Report; 3, Financial Statement; 4, List of Subscribers.'

In regard to Rule 7, Mr. F. H. Lemare said that the printing of the County Association's Report was a considerable tax on the funds of the local organizations, especially when as many as fifty from each Association were required by the Central body for the purpose of being bound up for distribution. In proportion with the increase of County Associations, there would be an

increase in the number of Reports required from each County Auxiliary, and this would prove an excessive burden on the poorer Branches; besides which, he saw no utility in the distribution of these bound Reports to local Associations. Mr. Dunman, Mr. Griffin, the Rev. V. H. Moyle, and Mr. Sambels, entirely dissented from this view, believing that a great amount of good resulted from the circulation of the Reports, which afforded an opportunity for interchange of thought and opinion among the different Branches. The Chairman also pointed out that by means of the bound volume of Reports, all information respecting the executive of any one of the Branches could be obtained at a glance—a circumstance most important sometimes. Mr. A. H. Martin moved, and Mr. Dunman seconded, Rule 7, which was passed *non. con.* in the following form:—'That a certain number (to be named by the Secretary of the Central Association) of copies of these Reports be sent to the Central Association to be bound up with its Annual Report; a bound copy of such Reports to be sent to each affiliated Association. It is essential that the Reports should be uniform in size, otherwise they cannot be bound together.'

The Rev. A. Roberts moved, and Mr. Martin seconded, 'That the word "Association" be substituted for the word "Societies" wherever the latter expression occurs in the Conditions and Privileges of Affiliation,' which resolution was agreed to unanimously.

The Committee of the B. B. K. A. having decided that every Affiliated Association, having fulfilled the conditions of affiliation, should be entitled to certain privileges, and all other privileges and advantages which might thereafter be established for the benefit of County Associations, it was resolved that the privileges of affiliation be constituted as follows:

(1) Moved by the Rev. A. Roberts, seconded by the Rev. Mr. Mitchell, and carried unanimously: 'That every affiliated Association may obtain from the Central Association any information regarding its laws, regulations, or matters connected with the advancement of Bee-culture.'

Mr. Dunman asked permission to raise a discussion on Rule 1 of the Conditions of Affiliation, which was passed at a previous meeting during his absence. He thought that most County Associations could not afford to send two delegates to each of the Quarterly Meetings of the B. B. K. A., and that the rule should be amended so as to read 'one or two.' The Chairman, Mr. Hooker, Mr. Martin, the Rev. Mr. Selator, and Mr. Griffin, deprecated any tampering with a rule passed at a previous sitting, and explained that the clause as it stood did not make the attendance of two County representatives at the General Quarterly Meetings compulsory.

(2) Moved by the Rev. Mr. Burkill, seconded by Mr. Griffin, and carried unanimously: 'That every Affiliated Association shall have power to make, through their representatives, who attend the Quarterly Conferences of the Central Association, any suggestions or recommendations for the mutual advancement of the relations between the Central and Affiliated Associations. Notice of such motions must be given either at the previous Quarterly Conference, or fourteen days previous to the date of the Conference at which it is to be discussed.'

In reference to Clause 3, Mr. Sambels suggested that the words 'in sections' be struck out; but the Chairman explained that this could not be done, because one of the rules of the B. B. K. A. provided that silver medals could only be given for comb honey in sections.

(3) Moved by Mr. Griffin, seconded by the Rev. Mr. Burkill, and carried unanimously: 'That every Affiliated Association shall be entitled to receive a Silver Medal, a Bronze Medal, and a Certificate of the Association, to be offered as prizes for honey; the Silver Medal at least to be offered for the production of comb honey in sections. These Medals and Certificates to be

open for competition only to Members of the County Association residing within the County, or within such boundaries as shall be defined by the County Association. No competitor to enter for more than one County Competition.

Mr. Huckle stated that he had had some difficulty in making a Kentish gentleman understand that only Secretaries of County Associations (and not Members) could obtain the publications of the B.B.K.A. from the parent body at trade price. County Members must apply to their Local Secretaries for this privilege.

(4) Moved by Mr. Martin, seconded by Mr. Sambels, and carried unanimously: 'That every Affiliated Association shall be entitled to purchase, through their Secretary, all the publications of the Central Society, at the ordinary trade price.'

Mr. Lemare thought that Clause 5 ought to be amended so as to provide that the County Associations should only have to pay the carriage of the Bee Tent from London, stating that on one occasion the Surrey Association was mulcted in a large amount for the conveyance of the tent from a distant locality. Mr. Huckle promised to inquire into the circumstances narrated by Mr. Lemare, and explained that there was no possibility of the contingency feared by that gentleman taking place, because the parent Association had now three tents, each of which was forwarded from place to place only within a certain area, consequently many Associations would have less carriage to pay than if they were charged the fare from London. Mr. Griffin objected to Mr. Lemare's proposal, stating that distant County Associations would suffer thereby. The last time the Devonshire Association had the bee tent at Exeter it was conveyed from Truro, the carriage being a small amount. Clause 5 was then agreed to as follows:—'That every affiliated Association shall have the free use of a bee tent at their Annual County Show, and be entitled to all the proceeds accruing from its use, on condition that the travelling expenses of the tent to and from the exhibition be paid by the affiliated Association.'

Mr. Lemare called attention to the fact that the name of the Duke of Connaught, who was Patron of the Surrey Association, had been added to the list of *ex officio* Vice-Presidents of the central body, instead of that of Mr. Hodgson, who was President of the local branch. The Chairman stated that this was strictly in accordance with Clause 6, but that if the Surrey committee preferred Mr. Hodgson's name to be placed among the *ex officio* Vice-Presidents of the B.B.K.A. instead of the Duke of Connaught, the parent Association would have no objection thereto.

6. Moved by the Chairman, seconded by Mr. Hooker, and carried unanimously: 'That the Presidents or heads of County Associations are *ex officio* Vice-Presidents of the Central Association.'

7. Moved by the Hon. and Rev. Henry Bligh, seconded by the Rev. Mr. Schater, and carried unanimously: 'Honorary Secretaries of County Affiliated Associations are *ex officio* members of the British Bee-keepers' Association, and are entitled to all the privileges of membership except the right of voting.'

At this juncture the Rev. H. R. Peel was compelled to leave the meeting, when the chair was taken by the Hon. and Rev. Henry Bligh.

8. Moved by Mr. Griffin, seconded by the Rev. Mr. Burkitt, and carried unanimously: 'The members of Affiliated Associations shall be allowed to avail themselves of the facilities which may be provided from time to time by the Central Association for the sale of honey and other bee produce.'

9. Moved by Mr. Griffin, seconded by the Rev. Mr. Burkitt, and carried unanimously: 'The Central Association will provide a judge if required to officiate at the Annual County Show of an affiliated Association, and also an examiner to conduct local examinations of

exerts desiring to gain third-class certificates in practical bee-keeping. The centre for these examinations must be named by the Secretary of the County Association, and approved of by the Committee of the Central Association. One month's notice (at least) must be given of the proposed examination. All travelling and personal expenses shall be defrayed by the County Association.'

It was agreed that the general advantages to be desired from affiliation were: 1. 'The interchange with other districts of experience and information, *e.g.*, on the advancement of bee-culture, on the practical measures for improving the methods of bee-keeping amongst the cottagers, on the practical means of disposing of honey, and the best means of organizing County Associations, and the dividing of counties into districts.' 2. 'The improvement of bee-culture by concerted action.'

Mr. Griffin proposed, and the Rev. Mr. Schater seconded, a vote of thanks to the Chairman, which was briefly acknowledged, and the proceedings were brought to a close.

Committee Meeting held at South Kensington, July 23th. Present: Rev. H. R. Peel (in the chair), Rev. G. Raynor, Hon. and Rev. H. Bligh, Rev. F. G. Jenyns, Rev. F. S. Schater, Captain Campbell, J. M. Hooker, and H. Jonas.

Examination Sub-committee reported that Mr. Mundella, chief of the Educational Department, had sent a favourable reply to the Association's memorial, praying that practical bee-keeping might be taught in the national schools as an elementary science, promising that the question should in due course be taken into consideration by the Department. Resolved, that the Examination Sub-committee, together with the Rev. H. R. Peel, be prepared, as a deputation from the B. B. K. A., to wait upon Mr. Mundella if required.

A Report and List of Seeds for Bee-plants, as prepared by Mr. Cowan, were submitted and approved. Resolved, that the best thanks of the Committee be given to Mr. Cowan for preparing this list; and that in future Messrs. Sutton be requested as far as possible to give the popular as well as the botanical names of the several plants.

A return of the attendances of the several members of the Committee since February 1884, was made as follows:—Rev. E. Bartrum, 4; Hon. and Rev. H. Bligh, 6; J. N. Bower, 0; Captain Bush, R.N., 5; Captain Campbell, 3; T. W. Cowan, 0; J. M. Hooker, 8; Rev. F. G. Jenyns, 6; H. Jonas, 7; W. Martin, 3; Rev. H. R. Peel, 6; Rev. G. Raynor, 2; Rev. F. T. Scott, 1; Rev. F. S. Schater, 6; D. Stewart, 6.

The next Committee Meeting was fixed for Wednesday, August 20th.

#### LINCOLNSHIRE AGRICULTURAL SHOW: GRANTHAM EXHIBITION.

The present show proved even more interesting than the previous exhibitions of the same character. There was a grand display of honey and of apian appliances in a large shed; and exhibitors in the class 'Collections' had on view between four and five hundred articles used in the production of honey, &c. Lectures and manipulations were given at intervals in a tent erected in the centre of the ground, the usual netting protecting the spectators. Mr. Baldwin, of Bromley, Kent, was the manipulator, under the direction of Messrs. W. Martin and G. Brett, the stewards of the department. There was a very nice assortment of cottagers' straw hives, with bees at work, showing the spectators how the honey may be taken even from the skep-hive without having to destroy the bees. Several Observatory hives were also shown, and excited much interest. The general superintendence of the department was in the hands of Mr. R. R. Godfrey

(the energetic local secretary of the Lincolnshire Beekeepers' Association), and the staging of the exhibits was undertaken by Mr. J. Bolton.

Nearly a ton and a quarter of honey was staged. The price ruled high, but the quality was better than usual, being full of flavour. A collection of bee-flowers, sent by Mr. Ingram, of Belvoir, was eagerly scanned,—by old bee-keepers especially.

The department was honoured on Thursday by a long visit from the Baroness Burdett-Coutts, who is so deeply interested in the work of the Beekeepers' Associations throughout England. We may mention that her Ladyship made several purchases. The classes for bees were fairly well filled, and, as usual, were the centre of interest. In Class 3, for super honey, there were only two exhibits, viz., Mr. Sells, of the Uffington Apiary, and Mr. R. Th. Pog of Langrick Ville, Boston; the total weight was 505 lbs. In Class 4, for extracted honey in glass jars, there were three exhibits, and the total weight was 1206 lbs. The whole was neatly put up in 1 and 2 lb. glass jars. Classes 5 and 6 included some beautifully worked sections, shown by twelve exhibitors; about 300 lbs. were staged. There were no fewer than twenty-three exhibits in Classes 7 and 8 for extracted honey, and 420 lbs. were staged. Class 9 was a grand class of supers of honey. Mr. Todman, of Belton, carried off the first prize with a lovely super; Mr. Sells second, with one of his nice little supers; and Mr. C. Shaw, of Earl's Fields, third, with a splendid specimen. In this class, Mr. C. Shaw contributed no less than five exhibits, all deserving of merit. In the classes for hives and appliances, Messrs. Abbott Bros., Southall, and Mr. Baldwin, Kent, Mr. Best, Boston, and Mr. Meadows, of Syston, were large contributors. A monster glass, containing 33 lbs. of extracted honey, was shown as extra by Mr. H. Yates; it was a treat to look upon, as proving what a stock of bees will do in ten days! Mr. Yates also kindly sent a grand super, of enormous weight, harvested in 1-76, the comb of honey appearing as fresh as if gathered during the present season.

The following is the list of awards:—

**BEES.**—For the best specimens of *Ligurian*, *Carniolan*, *Cyprian*, or *Syrian* honey bees, to be exhibited with the queen in an Observatory hive.—1. Abbott Brothers, foreign bees. 2. Withheld. 3. R. R. Godfrey, Grantham. For the best specimens of English bees to be exhibited with the queen in an Observatory hive.—1. Robt. Thorpe, Langrick Ville, Boston. 2. Abbott Brothers, Southall. 3. Withheld.

**HONEY.**—For the largest and best exhibition of super honey, the produce of one apiary during the year 1884.—1. Sells and Son, Uffington, Stamford. 2. Robt. Thorpe. 3. Withheld. For the largest and best exhibition of extracted or run honey in glass jars.—1. Robt. Thorpe. 2. J. R. Truss, Banton Heath, Stamford. 3. Walter Martin, Wainfleet. For the best twelve 1-lb. sections of comb honey, in crate.—1. Sells and Sons. 2. Mrs. Lydia Brown, Whapload, Spalding. 3. Rev. Chas. Plumtre, Claypole, Newark. For the best twelve 2-lb. sections of comb honey, in crate.—1. Sells and Sons. 2. James Gilbert, Stamford. 3. Withheld. For the best twelve 1-lb. glass jars of extracted or run honey.—1. John Lane, Marston, Grantham. 2. Walter Martin, Wainfleet. 3. Mrs. Maud Pinder, Ropsley, Grantham. Highly Commended, R. R. Godfrey. For the best twelve 2-lb. glass jars of extracted or run honey.—1. Mrs. Lydia Brown. 2. John Lane. 3. James Gilbert. Highly Commended, Messrs. N. B. and M. F. Kemp, The Mines, Selgebrook, Grantham. For the best glass super of comb honey.—1. George Todman, Belton, Grantham. 2. Sells and Sons. 3. Clement Shaw, Earl's Field, Grantham. Highly Commended, F. Lynn, Belton Ashes, Grantham; Clement Shaw.

**HIVES.**—For the best complete, and most practical hive on the moveable comb principle. Price not exceeding 30s.—1. Abbott Brothers; the Combination Hive. 2. James Gilbert. 3. S. J. Baldwin; the Gainsborough Hive. For the best complete and most practical hive on the moveable comb principle; price not exceeding 7s. 6d.—1. Abbott Brothers; the Cottage Hive. 2. S. J. Baldwin; the Lin-

colnshire Pet. For the cheapest, neatest, and best super for harvesting honey in the comb in a saleable form.—1. Abbott Brothers; the Kensington Super. 2. Abbott Brothers; the Economic Super. For the best honey extractor.—1. Abbott Brothers; Cylinder Honey Extractor. 2. Sells and Son. 3. Abbott Brothers; Little Wonder Extractor. For the best and most complete collection of hives and bee furniture.—1. S. J. Baldwin. 2. Abbott Brothers. 3. J. Best. For the best straw hive.—1. R. R. Godfrey. 2. William Barnes, Loundenhorpe, Grantham. 3. Mrs. Lydia Brown.

## BEES AT THE LOUTH HORTICULTURAL, POULTRY, AND DOG SHOW.

JULY 17th AND 18th.

In connexion with this important exhibition, the committee again wisely arranged for bee-manipulation and also provided a good prize schedule, offering a sum of 16*l.* to competitors in bees, honey, and hives, which brought together one of the best local bee exhibitions we have witnessed in Lincolnshire, and proved no small attraction to the vast number of visitors. A large tent was set apart for the exhibits, and the various classes were well filled, many of the exhibits were of high merit. The fight for high honours was chiefly between some old veterans of the Lincolnshire, viz. Messrs J. Best, H. S. Forman, W. Forman, W. Martin, H. O. Smith, Tom Sells, and the Rev. W. V. Turner, and right well did they sustain their usual reputation. The irregularity of numbering and lettering of exhibits (whether devised or not) was not what we like to see, and only served to perplex, bother, and trouble a judge unnecessarily. We would suggest that the usual system of numbering exhibits, viz. 1 to 100, be adopted in future, as the most easy and satisfactory.

The manipulating tent of the L. B. K. A. was under the able direction of Mr. H. O. Smith, ably assisted by Mr. Tom Sells, and was patronised by the rings of people who had the opportunity of learning from Mr. Smith's plain and practical addresses much that should help them in the more advanced method of bee-keeping. In the cottagers' classes there were some highly creditable exhibits, marking plainly the progress gradually working amongst them. R. R. Godfrey, Esq., of Grantham, was the judge.

## UFFINGTON COTTAGE GARDEN SOCIETY'S SHOW.

This worthy little Society had the privilege of holding its Show in the beautiful grounds of Uffington House (the seat of the Earl of Lindley), on Thursday, July 10th, when a grand display of flowers, fruit, and vegetables, was placed before the judges in connexion with the show. The Countess of Lindsay held a grand bazaar, which was most charmingly arranged, in the spacious ball-room, the object of which was to raise funds for maintaining the reading-room for the people of the village, in which her ladyship takes a deep interest. We need hardly remark that it was not likely that our old friend Mr. Sells, of the noted Uffington Apiary, would let slip so favourable an opportunity of doing his best to impart to the visitors some knowledge of bees and bee-keeping, and of offering them a feast in the shape of his grand honey productions. With the help of Mr. Tom Sells, Mr. Gilbert, and others, a beautiful exhibition of honey, bees, &c., was arranged; upwards of half a ton of honey was staged. The sections of comb honey were very good, and the quality of extracted above the average, the largest exhibitors being the Messrs. Sells, Mr. Truss, and Mr. Gilbert. Some splendid sections were shown by Mrs. Ramsden of the Rectory, and secured first prize, and the L. B. K. A. manipulating tent was placed in the lawn; and within the area, with their thousands of beloved pets, were to be seen Mr. H. O. Smith of Louth, and Mr.

Sells, Jun., in full go, doing their utmost to instruct the numerous spectators in the way they should go if they desired success in bee-keeping. Unfortunately the weather was not so favourable as could have been desired, and so marred what otherwise would have been a very successful exhibition. R. R. Godfrey, Esq., of Grantham, was the judge.

#### HANTS AND ISLE OF WIGHT BEE-KEEPERS' ASSOCIATION.

The chief Annual Show of this Association was held at Southampton on August 2nd and 4th, in connexion with the Royal Horticultural Society of Southampton, at their great summer show, in the Westwood Park. The weather was all that could be desired, the heat on both days being intense and the attendance very large. On the 4th (August Monday) nearly 20,000 persons passed the turnstiles, a considerable portion of whom visited the Bee Tent, to see the demonstrations with live bees and hear the lectures. In the Honey Tent adjoining there was a remarkably fine display of sections and honey in bottles, but the competition for hives and appliances was not so keen as the occasion would seem to warrant, considering the large public gathering and the excellent opportunity for business offered to apianian suppliers. For the best general collection of appliances there was only one competitor, Messrs. E. M. Hart and Co., who, as usual, brought an excellent assemblage of hives, samples of comb foundation, two observatory hives (an English and an Italian stock in each), and an extractor on a new principle, or, rather, old pattern revived, in which the cylinder, holding five standard frames, was made to revolve together within an iron cradle, whereby the chilling influence of direct draught was obviated. With one or two modifications and alterations, this machine would seem to possess several distinct advantages over the type in common use, and we hope Messrs. E. M. Hart and Co. may be induced to prosecute the matter. Another novelty was an exhibition of peat for bee-smokers, cut up into suitable form and packed in sixpenny packets, by the Eclipse Moss Litter Company, of Shapwick, Somerset. This fuel was used extensively in the Bee Tent, and proved itself extremely valuable to bee-keepers, burning slowly and giving out at the same time a mild but sufficiently strong volume of smoke. As this fuel removes another of the bee-keepers' difficulties, its introduction in a handy and cheap form marks another advance in the easy and safe management of bees. In Classes 4 and 10, for some unexplained reason, these usually popular competitions were scarcely seriously fought; in the former, that for the best-made hive by an amateur, the judges were unable to award a first prize at all; and in the latter, for the best skep of bees, only one prize was given. But the competition in the honey classes was, as usual, extremely keen, and in the matter of choosing sections the task of the judges was a most unenviable one. The superior finish, however, of the two-pound size over their smaller brethren made their selection a foregone conclusion, although the judges expressed their reluctance, as they considered the greater marketability a great point in favour of the smaller sizes. Their decision, however, in giving first prize to the same exhibit shown at the Winchester Show (July 4th) and similarly awarded, proved incontestably the justice of their choice, seeing that a different set of judges acted upon each occasion. Whether a special class for the one-pound size would not in future be advisable is a question for the Association to decide upon. In the matter of *extracted* honey the difficulties of the judges were not so great, for, although the vast majority of the exhibits were of unusual quality owing to the fine season, we feel bound to say that the twelve one-pound bottles exhibited by Mr. Edwin Russ, of Winchester, were of such sur-

passing clearness and quality we could but join in the general expression of gratification at discovering and tasting a honey which surpassed our ideal of what honey should be. It is a significant fact worthy of the attention of all bee-keepers that the sales of honey in this form usually exceed those in the form of sections by six to one, nearly the whole of the exhibits in Class 8 finding buyers at good prices; the lucky winner of first prize rapidly disposing of his supply at 1s. 8d. per one-pound bottle. The sales of sectional honey were not nearly so brisk, and as this was undoubtedly owing to the greater difficulty of transport it becomes a serious question whether it will not pay bee-keepers to adopt a regular system of glassing each section. The medals this year were again offered to those bringing the largest and best exhibit of honey in every form to the show, the silver one being awarded Mr. Hart for a magnificent pyramid of one-pound bottles, accompanied by numerous sections displayed round the base. Mr. Wm. Hunt won the bronze medal, and the Rev. Walter E. Medlicott, the certificate. The judges were Messrs. W. H. Dunman (Hon. Sec. Dorset B.K.A.) and E. Davenport (of the Wilts B.K.A.)

The Bee Tent of the Association was erected in close proximity to the Honey Tent, and was numerously attended, especially upon the second day, when the labour of lecturing devolved upon the Hon. Sec. for the County, E. H. Bellairs, Esq., and the Rev. W. E. Medlicott, assisted by Miss Medlicott and Mr. Robin Medlicott acting as amateur, not to say youthful, experts. The lectures were wisely divided into rudimentary bee-management and advanced bee-keeping, including full explanations of the bar-frame principle and its uses, so that practical lessons were available to novice and amateur alike.

A supply of Messrs. Huntley and Palmer's 'Honey Drops' Biscuits had been sent from Reading for the occasion, and we trust that the exertions of the Hon. Sec. and others may bear fruit in causing a large consumption of these excellent comestibles.

#### SOMERSETSHIRE BEE-KEEPERS' ASSOCIATION.

##### THE BEE EXHIBITION, STOGURSEY.

This honey and bee show, under the management of the Rev. Charles G. Anderson, the honorary secretary of the Somerset B.K.A., was held in two tents at a little distance from the horticultural section of the show. The honey in sections and comb, with some bee-keeping appliances, was staged in the first tent, through which the public passed by a gangway to the new bee-tent of the Somerset B.K.A. This tent, which was in use for the first time, has been made for the Association by Messrs. Waddon & Son, of Eastover, Bridgwater, under the direction of the hon. sec., and is capable of holding 100 spectators. The tent is a hexagon; the spectators are protected from the weather by a waterproof roof, and from the bees by transparent netting, while the bees have free access to the open air. The tent is complete in every respect, and does great credit to the makers. The Association will no doubt find the advantage of their new possession next season. One of the special points about the tent is the ease with which it can be put up and taken down. The whole is surmounted with a scarlet flag, with 'Bees' in white letters, and is a conspicuous object at any show. Several skeps of bees were driven during the day, and were supplied—some from Stoke Courcy, and some from Combluch and Otterhampton. The Rev. C. G. Anderson, who acted as expert, and was assisted by Mr. Hallett, gardener to Mr. R. Guy Evered, of Hill House, Otterhampton, showed the importance of bee-keeping as an industry open to every one as the principal point of his various discourses during the day. He also pointed out the fallacy of the idea that modern



bee-keeping was beyond the reach of any cottager on account of expense, clearly proving that any one with a little care may fit up an apiary for himself. In the exhibition tent the chief attractions were the observatory hive with two combs of bees visible on both sides, and the diagram, published for the use of lecturers, &c.

The principal exhibitors of honey were the Rev. C. G. Anderson (who had 54 lbs. in section and 18 lbs. in bottles), Mr. Thomas Hallett, of Otterhampton (Mr. Eyre's gardener), Mr. Warren, of Combwich, and P. C. Wise, of Otterhampton. The two special prizes given by the Rev. C. G. Anderson, consisting of a bar-framed hive and a skep cover, were made by the rev. gentleman himself, as examples of amateur work in bee-keeping, and the observatory hive was also made by him. No person could desire to have a better expert in connection with an exhibition of this kind than Mr. Anderson proved himself to be on this occasion. Sir Alexander Hood expressed his obligations to Mr. Anderson for the great amount of trouble he had taken in this matter and the valuable information and instruction he had given, and it was evident that all present shared this feeling of gratitude towards the rev. gentleman most fully.

Shortly after six o'clock the prizes were distributed on the lawn in front of Fairfield House by Miss Acland Hood, a suitable and congratulatory address having been previously delivered by the Rev. F. Meade-King, the honorary secretary.

#### WORCESTERSHIRE BEE-KEEPERS' ASSOCIATION.

This Association held its annual show at the meeting of the Worcestershire Agricultural Society at Pershore, on July 29th, 30th, and 31st. On the first day the weather was wet, but the other days were fine and there was a large number of visitors. The show of honey was an extremely fine one, and about half a ton was staged in a shed seventy feet long by twenty wide, which also contained the hives and appliances, and bees in observatory hives. The Hon. Sec., Mr. A. H. Martin, and Mr. C. Brown, the expert of the Association, assisted by Mr. C. H. Haynes and Mr. M. Woodward, were indefatigable in their exertions, and they succeeded in making the show a complete success. Mr. Brown conducted the manipulations with live bees in the beehive, and Mr. A. H. Martin explained the objects the Association had in view, particularly dwelling upon the great importance of bee-keeping by the market gardeners and fruit growers of the district, with a view to the fertilisation of the blossoms by the bees. He also explained what steps the British Bee-keepers' Association had taken with regard to the establishment of a honey depot at Reading, where honey could be sent for sale. His remarks were frequently applauded and attentively listened to by large audiences.

The Rev. C. N. Ogilvy, of Hambury Rectory, Bromsgrove; the Rev. J. Ross-Barker, Vicar of Evesham; and Mr. C. Brown, acted as Judges.

#### BEDFORDSHIRE BEE-KEEPERS' ASSOCIATION.

The above Association held their first honey show at Bedford on July 16 in connection with the Beds. Horticultural Society's Show, and offered about 100. in prizes, which were fairly competed for, and some honey of very excellent quality was brought forward. The Rev. J. E. Seager, Hon. Sec. of the Herts B.K.A., kindly came over and gave his services as judge; and also gave some very interesting and instructive addresses on bee-keeping.

The Rev. Dr. Wray of Bedford also very ably helped the cause of bee-keeping by giving valuable advice to those visiting the bee tent.

#### LEICESTERSHIRE BEE-KEEPERS' ASSOCIATION.

Under very favourable circumstances, this thriving Association held its third annual exhibition on the County Agricultural Society's ground at Leicester on the 30th and 31st of July. The undoubted success which was scored reflects great credit on the able, hardworking, and painstaking Hon. Sec., and his right-hand helper, Mrs. Ball. 'It would be a tremendous hard task to find an assistant Hon. Sec. to equal Mrs. Ball,' said an old hand, who had seen some few Bee-Shows in his day, 'she is all over the shop, and has all at her fingers' tip.'

The only little suggestion we would make is, that in future consecutive numbering of exhibits should be the rule, and that 1, 5, 10 should figure instead of I, V, X. The question, too, of making a charge to enter the manipulating tent is one that the Society would do well to consider before another season, people generally object to pay after once paying to enter a show ground. 'To move on,' as the man in blue says, we would remark that the numerous exhibits were well staged and all ready for the judge in due time, which very often is not the case at shows.

A large tent (25 yards long) nicely arranged and filled with exhibits met the eye of visitors. The Observatory hives stocked with bees, as is always the case, proved very interesting to passers-by. A splendid stock was shown by Mrs. Theobald of Leicester, which gained first honours.

In the honey classes some very choice sections were shown, but the objectionable practice of half-covering them with coloured paper took much from the appearance of the comb; one lot shown by Mr. Walter S. Pridmore without the paper decorations should prove to any observer the inutility of decorations of any kind. The extracted honey brought out fourteen competitors, and so good was the greater part of the exhibits, that it was almost cruel to leave so many below number three, and the same remark holds good in class V. Mrs. Rippin of Waltham found first honours in both classes. In the silver medal class lay the real fight, but our old champion, Mr. J. W. Bickley of Melton, with his grand collection of supers, the like of which one is rarely privileged to see, was the easy winner and pocketed the silver, whilst Mr. W. S. Pridmore carried off the bronze. In the hive classes there were some capital productions, and though there was nothing new in them, they were well fitted and cheap.

The collection classes closed with four entries, a show in themselves, and we hope some large sales were effected. The manipulations were conducted by Mr. Baldwin, who in his own happy way, entertained, amused, and we hope also instructed, the goodly number of visitors to the beehive on each day. Messrs. Bickley, Carter, Newham and Riley, rendered valuable assistance during the show. Nearly three-quarters of a ton of honey was placed on the table for competition.

#### BEE SHOW AT HEMSLEY, NORFOLK.

The Hemsley Cottage Garden Society, at its Annual Flower Show on the 29th July, had, like many such institutions, its bee-keeping department. For the last fifteen years the Society has given prizes for specimens of honey exhibited, but for the last three years its efforts in behalf of bee-keeping have been more extended; and the Society, though acting only for its own village of 650 inhabitants, has its own beehive and its own expert—Mr. Stephen Chaney, who won the first prize for bee-driving at the Yarmouth Horticultural Fête in 1882. At the recent Hemsley Show a prize was offered to residents in the village for bee-driving, Mr. S. Chaney acting as judge.

Two competitors entered the lists, Daniel Green and Robert Spooner. Green was the first performer, and succeeded in catching the queen in eleven minutes. Spooner then took his place with a new live, and effected his task in ten minutes, winning the prize of 5s., to the satisfaction of a goodly number of interested spectators. Subsequently, Mr. Chaney gave another illustration of the process, to which visitors were admitted without charge, and the tent was more than crammed. Many had thus the opportunity of initiation into the facilities of modern bee-keeping. For exhibit of honey the first prize was won by the Vicar, the Rev. J. Hadden, for sections and jars of extracted honey; the second by S. Chaney. In distributing the prizes, the Vicar observed that though he had at last the satisfaction of beating his friend, Mr. Chaney, the credit was due to the latter, for it was to S. Chaney's tuition and assistance that he owed whatever success he had achieved.

## Correspondence.

\* \* \* All Correspondents forwarding Letters for insertion in the Journal, Reports of Associations, Shows, Meetings, Echoes from the Hives, Queries, &c., are requested to direct their communications to 'The Editor of the "British Bee Journal," c/o Messrs. Strauchways & Sons, Tower Street, Upper St. Martin's Lane, W.C.'

### FOUL BROOD.

I am much obliged to Mr. Cheshire for introducing my name in his very able paper on Foul Brood, as it enables me to explain whatever credit there is for the suggestion of carbolic acid as a cure for this disease is due to Professor Tichborne, of the Apothecaries' Hall, Dublin, with whom I had a conversation in October 1881 on the subject.

My first experience with foul brood was in the summer of 1880, when it appeared in a Ligurian stock from which it spread to all the stocks in my apiary. Without loss of time I treated them with salicylic acid solution prepared according to Mr. Cowan's formula, using the solution in syrup for feeding and in spraying, but without success as the disease spread apace. At the end of the season I got some driven bees, and with them I strengthened my stocks for the winter. Next year, as soon as the weather permitted, I changed them into new hives, removed any combs in which diseased cells were found and began feeding with syrup medicated with Mr. Cowan's solution as a prophylactic, but without success, as the disease spread so rapidly that I was obliged to destroy twenty-five of the worst combs taken from four stocks in the course of the season of 1881, during the whole of which I had salicylic acid in one form or other in constant use. Before packing up for the winter I strengthened the stocks with driven bees as before, and left them as well as could be expected under the circumstances.

Before going further I wish to explain that in addition to using the salicylic acid in the solution mentioned above, I used it dissolved in alcohol, and also in a subliming apparatus of German make, without producing any good result, and this I attribute to the acid not being volatile at ordinary temperatures. In other words, its action as a disinfectant or antiseptic does not extend beyond the parts of the hive or combs with which it is brought into immediate contact so that a single foul-broody cell left untouched by the acid would still remain diseased, while all the other cells and the hive might be thoroughly disinfected. Another objection to salicylic acid is its insolubility. It is true that it is readily soluble with borax, but the resulting solution (salicylate of soda) seems to me to be one in which the

disinfecting properties of the acid are, if not lost, neutralised to a very great extent. Salicylic acid is readily soluble in alcohol, but it precipitates when an excess of water is added, and when used in syrup scarcely a trace of the acid remains in solution. But to resume.

In October 1881, I spoke to Professor Tichborne (to whom I am glad to have this opportunity of publicly tendering my thanks), and he suggested carbolic acid as a possible remedy for the foul brood. As it was then too late to do anything that year, I had plenty of time to decide on the *modus operandi* for the next season, and the first thing was to ascertain what make of the acid would give the best results. After trying several samples, I found that Calvert's Carbolic Acid Crystals, No. 1 (B. P.), was readily soluble in cold water while it volatilised at any given temperature more rapidly than any of the others. I prepared a solution by melting one ounce of the acid and pouring it into a quart of cold water, and it was ready for use.

On my examining my stocks in the beginning of March 1882, I found that in all of them breeding had been going on for at least ten or twelve days previously, but the brood was nearly all dead and the bees were so weak in numbers that I thought it better to allow them to die out and to make a fresh start with early swarms. About this time the bees began to fly in search of food, and as I did not wish to go to the trouble of placing feeders on the hives I gave them some syrup (to which I had added the carbolic solution in the proportion of one and a half teaspoonful to a pint of syrup) by filling a pickle jar and inverting on a piece of slate which was placed at some little distance from the hives. The bees took this mixture readily, and continued taking it until the middle of April, when they were flying in considerable numbers. Prompted by curiosity more than anything else, I examined them and was surprised to find them in a flourishing state. I transferred them into clean hives, and between June 15 and June 25 I had a heavy swarm from each stock, one of the swarms weighing 7½ lbs. nett. After swarming, I requeened four out of five stocks with Italian queens with the result mentioned in the quotation which Mr. Cheshire gives from my letter to him.

Up to the time when the Italian bees began to emerge from their cells, it seemed to me that I had at last got a remedy for foul brood. Every queen-cell which I destroyed contained a healthy queen in one stage or other, and the bees increased so rapidly that I was unable to provide hives for them. I wished to let the bee-keeping fraternity know of my success; and I called on Mr. Cheshire and placed the facts before him.

It may be worth mentioning that I have used the carbolic acid solution for disinfecting hives, frames, division boards, quilts, &c. My plan was to place the articles to be disinfected in a hive and cover them with the quilt leaving the feed-hole open. A small boiler (holding about a pint) made of sheet-iron was then filled with the acid solution and placed on the quilt, and the solution was made to boil rapidly by means of methylated spirit in an ordinary tin canister cover. A pipe from the top of the boiler carried the steam down through the feed-hole in the quilt into the hive. I find that about a quarter of an hour of this treatment is sufficient to disinfect a hive and any number of frames or articles it will contain, but before using them they should be scalded and exposed to the sun for a few hours to drive the smell of the acid off. Some of the hives and quilts I have in use at the present time have been treated in this way after being used for diseased stocks, and I have not had any trouble from them. If any of your readers wish for a sketch of the disinfecting apparatus, I shall be glad to send you one. I made mine from an ordinary paint can, and the total cost did not exceed four shillings.—ROBERT SPROULE, *Dublin*.

## FOUL BROOD.

The great interest that all bee-keepers take in Mr. Cheshire's experiments in foul brood is my excuse for this letter, which gives some of my experiences confirming Mr. Cheshire's new theories. Some three years ago I foolishly bought some skeps stocked with bees and combs. These were my pest-houses. They were full of the so-called foul brood, and soon became extinct, but not, alas! before they had infected a fine stock of blacks in a bar-frame hive. Hence date my troubles. This hive last year gave me a splendid swarm and about 40 lbs. of comb-honey, besides extracting about 15 lbs. On my return from abroad I examined the hive and was disgusted to find it full of foul brood. But there was another feature. The bees were lying in thousands dying at the bottom of the hive, unable to crawl up the combs. My only remedy was to place the few remaining bees and their queen in a new hive, with comb, and feed them, which I did. I then destroyed the combs and disinfected the hive by washing thoroughly and spraying with salicylic acid solution. It has not since been in use. At that time there appeared a letter in the *Journal* for September 1, page 157, in which two correspondents complained about dead bees having died much as mine did. I wrote a letter, thinking the occurrence might be explained by foul brood having been so far got under by the bees that the brood were able to hatch out alive, but unable to fly. The letter got lost somehow, at least that part was lost, and another portion on another subject printed. This, of course, I now think incorrect, as Mr. Cheshire's proof that the bees themselves are liable to the disease fully accounts for the facts. Now to the rest of the story. The new hive, made from the old, perished during the winter with its queen, as the bees left were too few to keep any warmth. Now we come to the swarm that the old hive sent out. This wintered badly, and was put in a new hive this spring. It has given me about 15 lbs., but now shows signs of foul brood, thus proving that the queen and her bees took it with them when they swarmed. I have ordered some Absolute Phenol, and intend to repeat with a Ligurian queen, introducing her about the middle of this month, and feeding judiciously until October. I will let you know the results.—O. W.

## PHENOL: A CURE FOR FOUL BROOD.

Mr. Cheshire would add to the great boon he has just conferred upon bee-keepers if he would give a practical recipe for his new food for curing foul brood.

So many pints of water.

So much sugar.

So much phenol.

To give '1 part in 500' is beyond the calculating powers of many sufferers.—H. F.

## ASSOCIATION FOR DURHAM.

At the commencement of this year I intended to moot the question of forming an Association for this county when reading in the *British Bee Journal*, May 15, page 159, 'With the exception of Rutlandshire and Westmoreland, there is not a single county in England which is without the prospect of having an Association.' I deferred my intention. In the map of England and Wales published June 15, page 198, the county of Durham is shaded as having an Association in prospect. If any gentleman has taken in hand the formation of an Association, I should like to correspond with him, as I could perhaps assist him by procuring members in this neighbourhood. I enclose my card.—LEARTO'S, *Wear-dale*.

## THE LIVERPOOL SCHISM.

I am tempted to address a few words to the *British Bee Journal* on this subject, not because I am able to throw any light upon it, but rather because I am anxious to bear record of what I may describe as the universal reprobation with which we in the South regard the news too prominently brought forward in the current number of the *Bee Journal*. Mr. Kaynor's logical conclusions appear to be unanswerable, and his measured strictures are quite sufficient one would suppose to for ever silence a schism which I can only imagine has been got up for journalistic purposes. It must be apparent to the meanest intellect that if we are to keep the position already assigned to modern bee-keeping and not degenerate into little petty local coteries, we must not permit for a moment the question of separation to arise; for although in some cases it might be difficult, and even impossible, to show that the Parent Association was a financial benefit to the counties, this must arise rather from the local advantages of wealth, &c., than from any inherent weakness in the capacity of the B. B. K. A. to act as a centre. I would carry the matter further, and suggest that the wealthy counties of England should assist their poorer brethren by subscriptions paid through the funds of the Central Association, as, indeed, was done in the case of the Hants B. K. A. this year, by granting an additional *Shover* and above their regular affiliation fee.

The expression of these thoughts, however, is not the main object which has induced me to write. Whatever we may feel about dissensions and strifes, whether from within or merely upon the outer fringe, all bee-keepers must recognise the paramount importance of keeping their *Journal* the recognised organ of all British bee-keepers above reproach and the personalities too freely indulged in by so moderate periodicals. It seems to me, sir, that in order to slay your mouse you have exercised—well, too much vehemence, and that, too, in what may, without disparagement, be described as the best number of the *Bee Journal* this year, containing as it does Mr. Cheshire's valuable and close deductions on foul brood, and Mr. Hehner's priceless contribution on adulteration of honey. The promise that the subject is to be 'continued in our next for some time to come' has induced me to express a regret in which I believe the vast majority of your readers will share, and which you will, I trust, consider is occasioned not by any sneaking sympathy with the miserable being you denigrate as 'Mahdi,' whom you propose slaying thus often, but rather out of a desire to see the *British Bee Journal* ranking as English journals do when compared with Continental ones, and able to hold against all comers the position of 'recognised organ of all British bee-keepers.' E. H. BELLARS, *Cheshchurch*.

## ELECTION OF COMMITTEE OF THE BRITISH BEE-KEEPERS' ASSOCIATION.

You challenge the Editor of the *Record* to prove his statement that the Committee of the B. B. K. A. are self-elected. Here is a very easy way for him to do so,—let him put himself up for election next January, and if he can elect himself we won't call him a *false prophet* again. BILL FRANCHISE.

## BEES TRAVELLING — FASTENING CHESHIRE RAKES ON THE BARS.

On reading 'Useful Hints' in last issue of the *Journal*, I was surprised at the instruction given to those intending to travel their bees, viz.:—'That they should travel with the combs running parallel with the axle to prevent swaying from side to side.' Now this is neither sound in theory nor advantageous in practice, as, in most cases, it means utter ruin to your stocks, instances of which

are frequently under my eyes; for it is a common occurrence to be called into the street to receive bees that have been brought from a distance, to find them with their combs quite broken down, and the bees drowned in the sweets they have laboured so hard to collect, *all* through travelling with the combs parallel to the axis. The motion of a cart is from back to front, consequently the combs must have a ready sway with each motion of the cart. The combs have really a resistance of as 15 to 1 when placed at right angles to the axle compared with the motion when parallel with the axle.

As I have to pack some hundreds of stocks of bees during the season, perhaps it would not be out place to offer a few suggestions as to the best means of packing them.

Remove the bars carefully one by one from the hive, and twist two Cheshire rakes round each, about two inches from the ends of the bar. A piece of perforated zinc is then fastened over the top. If a stock from a straw skep is to be travelled, the skep is inverted and corks are pushed between each comb, and a piece of *open* or *course* canvass is tied over the bottom. If the skep has been previously skewered corks are not necessary. No matter whether the stocks are going by road or rail strict orders should be given to place the hives with combs at right angles to the axles. In this way I have taken hundreds of stocks of bees all over the country and never had a single comb give way. I hope these few remarks may prove useful to those about to take their bees to the heather.—G. J. BULLER, *Welwyn, August 8, 1884.*

[Having forwarded the above to the writer of the 'Useful Hint' adverted to, the following is his reply:— 'It would have been better if Mr. Buller, before writing the above, had followed a cart for a few yards over rough ground, and used his eyes. He would have seen that as the wheels go over stones and into holes the body of the cart sways from side to side, hence the combs should always be parallel to the axles, so that the swaying shall be in the direction of their length. A cart properly stowed *does not sway* in the direction of its length, and a careful driver will prevent it by shifting his own weight forward when going up hill, and backward when going down, so as to relieve his horse. Of course a lame horse at a trot will keep the whole cart on the swing. But a horse with bees behind him should never go beyond a walk. Then again, who that has ever felt the swaying of a railway carriage from side to side when going round sharp curves and over points would recommend the combs to be placed in such a position that they would partake of this motion? If Mr. Buller directs the senders of bees to him to pack them as he says, the only wonder is that he ever gets a sound comb delivered to him.']

## Reviews.

AN ESSAY ON BEES. *Being the Experience and Observation in his own Apiary, with hints on their Natural History.* By 'Pan' (Glasgow, Munro, 1884.) This essay on bees received in the year 1882 the prize offered by the Highland and Agricultural Society of Scotland for the best essay on bee-culture, with the view of encouraging and improving apiculture in Scotland. The author of the essay is Mr. William Thomson, of Auchinraith, Blantyre, known to the bee-keeping world as 'The Lanarkshire Bee-keeper.' In this essay the reader has the benefit of Mr. Thomson's forty years' experience as a bee-keeper. The essay is preceded by an interesting history of apiculture in Scotland in general, together with that of the Caledonian Apiarian Society. As might be anticipated, an essay by such a veteran as 'The Lanarkshire Bee-keeper' fully covers the

whole management and natural history of bees and the economy of bee-keeping. The essay throughout is thoroughly practical, and its teachings are evidently the result of the author's 'experience and observation.' By offering a prize for the best essay on bee-keeping, the Highland and Agricultural Society of Scotland have shown their solicitude not only to improve the condition of the rural population generally, but also to promote the pursuit of bee-keeping especially; and we trust that the object they seek to obtain may be effected by the publication of this work. The essay is accompanied by numerous wood-engravings, which, however, are rather to be viewed as illustrations than as explanatory of its contents.

BRITISH BEE-KEEPER'S GUIDE BOOK. By Thos. Wm. Cowan, F.R.S., F.R.M.S., &c. Fourth edition (Houlston & Sons, 1884.) In the course of two years and a half three large editions of this work have been exhausted. Seven thousand copies of it have been sold, and the author has been called upon once more to revise and enlarge it. The stamp of public approbation has been firmly set upon it. Its reliability as a guide to bee-keepers is acknowledged both in England and abroad. The present edition has been much improved, and various additions have been made. A minute account of the hive called 'the Raynor Eclectic Hive,' has been given, together with a description of the apparatus used by M. E. Bertrand of Switzerland for curing foul brood by Hilbert's fumigating process.

## Echoes from the Hives.

*Elton-Wick, Bucks.*—I think bees have done very well in this neighbourhood during the season; one member of the County Association, a Mr. Bacon of this place, has to my knowledge sold sections to the worth of 5*l.*, and I have seen other sections just taken off that bring the total up to 100 lbs., and this is not a good locality. I myself have done very well with the same number of stocks (5), have been slinging every week, besides taking sections, also had two swarms. I think the secret of such success is we got our stocks in good order for the first fruit blossoms; if we lose that, we seldom have any honey. There are other bee-keepers in the neighbourhood, but cannot state their condition, doubtless they have done as well, as they are more experienced than myself, and had swarm out very early. I must add my little experience with pure Ligurians: I had a queen from Abbott's last August, and before the winter all blacks had died out, and a nice stock of pretty bees for wintering. They did very well, I worked them into a strong stock. I cannot say how much honey was taken, but some considerable quantity, they have not swarmed. They are *very* quiet when manipulating; it is a treat to see how quietly they remain on the combs, and very rarely do they sting. Another year I mean (if all's well) to test their honey-getting as accurately as I can. I like them very much.—G. HOWELL.

*North Leicestershire.*—Rain set in on the 7th inst., and from that date up to the present, 24th inst., the bees have done next to nothing, constantly recurring showers keeping them pretty well confined. Clover is fading away, and the limes, though in full bloom, are almost unvisited by honey-bees. Accounts of the honey harvest are very conflicting: some bee-keepers speak of heavy yields, while others say the season is a failure. 3·65 inches of rain have already been gauged, but the weather has been very warm, the thermometer standing above 70° on no less than eighteen days. On the 29th fair weather set in, and after a day or two's hesitation, the bees fell to once more on the clover and limes. Hives are 'sweating' again, and if the present warm weather continue, a considerable increase in the honey yield may be expected.—E. B.

*Lauder, Midlothian, 11th July, 1884.*—Bees have done well here this season, but for a week past we have had very heavy rains with thunder more or less every day. I purchased a skep and stock of bees on 10th March; first drone seen on 3rd June; made an artificial swarm on 5th June, and put them into bar-frame hive. On June 17th, drove a second swarm and put them into bar-frame hive also, then put skep on top of bars of a third hive, and now the bees are filling it as a super while they are working out the combs in the frames below. I have eight frames in each of the swarms which the bees have nearly filled with combs. I put in half-sheets of foundations. I am pleased with my first attempt at bee-keeping.—JOHN TURNBULL.

*Sittingbourne, Bobbing, July 16th.*—We have not gathered a very large quantity of honey, though I have proved the truth, that hives strong in spring will pay, whilst those weak do nothing; some having filled nine large frames in an upper storey twice over, whilst one hive has not gathered any extra. The east wind which prevailed for more than three months seems to have checked the flow of nectar. My first extractings were beautifully white, and solidified so quickly that a great deal remained in the strainer without being able to run through. About a fortnight ago I found the honey in parts of the combs just filled almost black. Can any one say what flowers would be likely to have yielded it? Do not some say that bees will not work up chips of wax? I gave two hives each a dish of unsalting of honey to clean. One hive stirred them about, burrowing in to get the honey; but the other hive built them into a mass of comb in the dish, so that they could walk right through in every direction, and clear up all the honey which the others failed to do where the trimmings were very deep. ERNEST HARRIS.

*Beds, Coppe, July 17th.*—Since my last we have experienced a sudden change in the weather, it being everything that could be desired until July 9th, when a severe thunder-storm, lasting four and a half hours without a lull, broke the spell, and it has rained more or less every day since. We have had nothing whatever from the limes, as they were hardly out when the weather broke, and have, of course, been spoiled by wet. I have taken 51 lbs. and 35 lbs. top honey from two best hives, which, I think, is very good considering there is not more than an acre of white clover accessible to bees this year. I have not touched body of hives yet, but must do so the first opportunity. A. F.

*Somersham, Hunts, July 23rd.*—Experiences during the past two months have been very varied in this district. While I have had between fifty and sixty pounds of sectional honey from each of my hives, some of my neighbours have not had a super. Stocks have swarmed badly this year, and casts have been almost unknown. Those who have had good stocks, and have supered in time, have reaped a good harvest. A general complaint is made of the queen entering supers. I use no perforated zinc, and only in two hives have I found that the queen has entered the sections, one lot 2 lbs., the other 1 lb. The swarm mentioned in my last echo, which I had from Mr. Jackson, has given me nearly 50 lbs. of honey in 1-lb. and 1½-lb. sections. My Anglo-Cyprian hive has been the most successful in the whole apiary. I am now busy preparing for our show to-morrow, so I will give a few more notes for next issue. Our honey harvest closed with June. The rains in the first week of July have caused the clover to spring up again, but I look for no more surplus honey. I have not had a good look round the neighbourhood yet, but I think that this has been the best year's experience for many years past. C. N. WITTE, Hon. Sec. Hunts B. K. A.

*Honey Cott, Weston, Leamington, July 24th.*—During the last fortnight very little honey has been gathered in

this neighbourhood. White clover—the staple plant of our honey producers—is unable to secrete its nectar through lack of settled hot weather. Honey gathering for this year is practically at an end, as there is no heather or late blooming forage to fall back upon. This fact is well attested by the bees themselves, who are beginning their usual murderous attacks on the drones, and getting rid of the idle honey-eaters from their hives. Though now unfavourable weather for honey gathering, the interior of the hives bears witness to the better part of the season which has already passed away. The extractor is now in full swing, depriving some of the overlaid combs of their superfluous contents—an action which the bees do not appreciate, or seem to think is at all for their good. How to deal with straw skeps, which are loaded with honey, will, I think, be a problem that will trouble the bee-keeper who wishes to keep these stocks through the winter, without having to take any more trouble than just to let them stand through the winter till spring.—JOHN WALTON.

*North Wals, July 26th.*—Last month was a fine month, no rain falling between the 8th and 21st. Very heavy falls of rain took place on the 6th and 25th, exceeding 1 inch on each day, and the total fall for the month was 3.48. The maximum temperature in the sun was 136° on the 25th. The mean was 118.2, which was higher than that of the previous four years; but lower than any other of the nineteen previous years. Sunshine was very deficient during the first ten days of the month. There were 149.4 hours of sunshine, which was less than in 1883 or 1882. The present month has not been very favourable, and whilst a good deal of honey has been gathered, the anticipations of the earlier part of the season will not be realised. Rain has fallen on every day except four during the present month, and the weather seems to be quite unsettled. Drones have been under notice to quit for several days past, and from some of the hives drone-brood is being thrown out. Unless we get a further spell of fine weather at once the honey harvest is practically over. H. B.

*South Cornwall, Aug. 9th.*—As you have on hand several 'Echons' to be reproduced before they fade away, you may hardly care to hear me at present. But, to risk it, I may say that after the breaking up of the glorious bee-weather in the middle of July, we had at intervals two or three bright days till the end of the month. But as the fortnight was for the most part hot, the bees were venturesome and did some work; since that they have not begun much *new* work, but have used the fine first week of August for finishing off sections, taking matters somewhat easily. Body hives are very full. A small skep in this neighbourhood, after sending off two swarms, swarmed its inhabitants clear away the third time. But bees have been doing very many queer things of late, as I dare say most apiarists know. C. R. S.

*Carraig-by-Keith, A.B.*—Bees are doing pretty well. My best hive is working out thirty-two sections 2 lbs. each; also a quantity of 1-lb. sections. At side seven full ones have been removed. Clover is in full bloom. Swarms have been very abundant. For several days the weather has been rather dull; soaking up is, however, going on inside the hives. A. COCKERUN.

*Bass, July 17.*—Bees here are doing well this season. There is a splendid crop of white clover, and the heather is now coming into full bloom. It is mostly all the old-fashioned straw skeps that are in use herabouts. By another season I expect that by the help of the *Bee Journal* bar-frames will be in more general use.—A. BANFESHIRE BEE-KEEPER.

*Finn Valley, co. Donegal, Aug. 7th.*—Honey harvest over, but it has been the largest since 1876. At Strabane show, 5 cwt. of honey was entered, while last year there was not a single entry. A large number of straw skeps are commencing the moveable comb system, as they see the superior advantages of it.—APICULA.

## Query and Reply.

QUERY No. 791.—(APICULA.) 1. Would you kindly say what you think was the cause of two of my swarms leaving with only eggs in queen-cells? also the cause of the two larvae in a single cell?—A. Swarms will often depart before the queen-cells are sealed, especially in very warm summers like the present. Italians and Syrians will swarm when the queen-cells are quite rudimentary, and sometimes before they are even commenced. 2. When removing sections, do you not wait for the cells next wood to be sealed over? I find that my bees do not build the sections out to the wood.—A. Yes, the cells ought to be filled and capped, or sealed, evenly. The perfect sections should be removed, and the unfinished ones placed over the centre of the hive.

### NOTICES TO CORRESPONDENTS & INQUIRERS.

- B. SKINNER.—*Raising Queens*.—It is now too late to raise queens. Early and late-bred queens are always inferior to those bred in the height of the season. They are short-lived and far less prolific, as a rule. It is far better to buy good queens raised in full colonies in the month of June, or early in July.
- C. M.—1. *Removing Sections*.—The present dull, cold weather, and the consequent failure of the honey flow, by keeping all the bees at home, have rendered them irritable. Racks of sections, entire, should be removed from the tops of the hives to some sheltered part of the garden, or taken into an outhouse, and, the bees having been gently brushed off all sections, the sealed ones should be stored, and the unfinished ones either returned to the hive for completion or extracted, and, when cleaned by the bees, reserved for use another season. Except in the heather countries, it is too late now to get them finished. Rolls of thick brown paper, loosely rolled, and lighted at the lower end, are best. Your smoker may be in fault. The chimney may be kept on when not in use. Your bees become thoroughly irritated by the scent of the 'sting poison.' When bees are so irritated as to use their stings freely it is better to throw a sheet over the hive and to retire for a time until they become quiet. In this case a good smoker, throwing volumes of smoke, and the gentlest, quietest manipulation possible, are necessary; indeed, it is best to leave manipulation until you get a fine day. Before section-racks are returned to the hive the bees must be driven down by smoke. The bees should be kept out of the space when the wedge acts. We suspect you are using inferior section-racks. 2. *Extracting*.—Uncap one side of comb first, and, when extracted, uncap the other and turn the comb. The comb fits in end downwards. The extractor should not be turned too fast. Practice alone will teach these little details.
- A. HULSE.—1. It is a great mistake to use smoke too freely when taking off supers, especially smoke of rags, fustian, &c., as the honey afterwards retains the scent and flavour of the smoke, and any unsealed honey is entirely spoiled. We have tasted sections spoiled by over-smoking as to be rendered quite unsealable. The small quantity of smoke used should be from brown paper, and very little is required if sections or supers are removed at mid-day on a fine day, when the bees are at work in the fields. We know of no plan by which the evil can be remedied, unless, perhaps, fumigation with salicylic acid. 2. *Number of Frames for Winter*.—Six would be sufficient.
- R. E. CRESWELL.—1. *Utilising refuse*.—The plan of putting out refuse comb for the bees to fight for is very unwise, as it leads to robbing, which is contagious, and when once set up is difficult to stop. The

best way to utilise cappings, &c., is (in the absence of a wax extractor) to put them in a jar in an oven until the wax melts. On cooling it will be found in a cake and the honey under it. This may be given in a feeder to weak stocks. 2. *Super foundation*.—The foundation forwarded is that which is generally used for supers. This does not usually give a perceptible midrib. Possibly the bees, instead of drawing up the walls out of the wax of the foundation, erected them of fresh wax, and so left the foundation of its original thickness. This would only happen when a sudden glut of honey sets in.

- H. JAMES, *Kilmington, Devon*.—*Driven Bees*.—1. Please refer to article on *Condemned Bees* in this number. 2. *Pollen-filled combs*.—The cause of the combs outside the queen excluder containing so much pollen is the difficulty of carrying it through. The pollen-filled combs are most useful to give to condemned bees, their own pollen having been left behind in the skeps.
- W. H. *Devizes*.—*Robbing*.—It was a clear case of robbing. Ascertain if you can out of which hive the robbers come, and turn both the robbed and the robber hive hind part before. This will generally stop it.
- A. E. N.—1. *Queenless stock*.—Yes, the bee which you sent is the queen, and your stock is therefore queenless. The old stock will raise a young queen for themselves, and there will be still time for her fertilization before the drones are killed off. 2. *Brood in the super*.—You ought to have smoked the sections to quiet the bees, and then removed the perfect ones, replacing those containing brood and the queen over the hole without any excluder. The brood would have hatched out and the queen gone down. 3. *Driving and Uniting*.—You had better drive both your skeps about twenty days after your mi-hap, and transfer the combs to a bar-frame hive, uniting both lots of bees, as the light skep is probably queenless.
- W. H. LLEWELLYN AND ARTHUR HARRISON.—*Beginning Bee-keeping*.—Procure and study Cowan's *Guide Book and Modern Bee-keeping*, subscribe to the *Bee Journal*, and become members of the Association of the county in which you reside. Do not attempt to start in too large a way. Begin with one or two hives, and increase stock with growth of experience. Start in the spring with the purchase of a swarm in May as early as possible from a hive that swarmed in the previous season. We prefer Ligurian bees.
- C. CORBETT.—As you say the skep is too old to last the winter we should advise that you transfer your bees to a bar-frame hive, and feed up for the winter. You would find that by so doing your interest in your bees would be considerably increased.
- J. SIMPSON.—1. *Honey in a Standard Hive*.—The deduction you have made for frame and comb is within the mark. 2. *Fertile Workers*.—These lay their eggs alike in worker and in drone-cells; the drones that are produced from the worker-cells are under-sized.
- T. A. S.—1. *Old Queen*.—It is desirable that you should examine your hive and ascertain whether the queen is present or not; as she is of a doubtful age, the probability is that she is what the Americans call a 'played-out' queen. 2. *Cast*.—The amount of honey in your combs would be sufficient to support the bees until the following spring.
- OSOKO.—*Fruit Juice*.—The contents of the bottle forwarded cannot be described as honey; your bees have evidently forcibly entered some neighbouring jam factory, or are plundering the winter store of some thrifty gudewife. We fancy it is raspberry juice that they have been carrying to your hives.
- A. B. C., *Beckenham*.—*Queens recommending Breeding*.—To cause your queens to recommence breeding, remove one or two combs to the outside of the dummy, first unsealing the honey and making a way for the bees

to get to them, or you may remove a few combs and feed either with extracted honey or thin syrup.

**W. COLLYER, Working.**—*Bees hanging Out.*—As you have heather now in bloom in your neighbourhood, we should advise you to put on a super, when probably the bees, which are hanging out because the hive would be too hot otherwise, will enter it and fill it for you.

**W. H. D.—1. Tapering Frames.**—Tapering frames are certainly easier to handle for very careless people, but no advantage presented itself to the Frame Committee of the B. B. K. A., when considering the standard frame to induce them to adopt them. As the standard frame has upright sides, we should advise you to keep to that form. **2. Cottage Woodbury.**—When Vol. II. of the *Journal* was written the Cottage Woodbury was considered a very good hive, but now it is out of date. **3. Wood for Hives.**—The materials of which a hive is made do not matter, provided they are well seasoned and the workmanship is good, and also all if the weather is kept out by good sound roofs. **4. The Journal.**—We should strongly advise you to obtain the issues for the whole of 1884, and to continue to subscribe to it; there are always new ideas cropping up and improvements being effected.

**W. J. T.—1. Young Queens.**—Young queens, after fertilisation, must be kept at the head of the nuclei until required for introduction. To cage them in other colonies for any length of time would seriously injure and perhaps destroy them. **2. Sections.** After two or three days, weather proving fine, when the bees are fairly started below, put on racks of sections, and, if honey is coming in, they will quickly take possession, while the work below will be carried on with increased ardour. **3. Number of the Frames.** The number of frames in a hive must necessarily depend on the size of the frame and the district in which the bees are kept. In a good honey country we consider that a hive should contain not less than twelve standard frames. If this number had been used your outside frames would have contained no brood. As it is you may now, or a little later on, put them through the extractor without injuring the small quantity of brood contained in them.

**S. M. GABRIEL.—1. Feeding with Doubtful Honey.**—If there is acidity in the honey do not use it for feeding bees; sugar syrup is far better. There is a paper by Mr. Simmons on autumn feeding in the present issue. **2. Ripening Honey.**—Bring the honey gradually over a slow fire to a temperature of 120°. Let it cool slowly and then store it in air-tight jars or bottles. If sold in its present state it will soon become acid. **3. Ligurian Bees.**—Yes; they are far superior to the German or English bee.

**APPELLA.—1. Extra Queens during Winter.**—Keeping queens at the head of small colonies during winter, for use at spring, is rarely attempted by our best experts. Your plan would probably result in the death of greater part of the bees attendant upon the queen, and the next severe cold would dispose of the rest. In a mild winter the difficulty might be overcome, but on the whole it will be found more economical to purchase queens at spring. **2. Phenol.** See advertisements in our last and present issues, and read Mr. Cheshire's paper. **3. Lid of a Queen-cell.**—Yes; the hinged lid on a queen-cell could be formed in no other way. The worker-bees dispose of the capping of the worker-cells in polishing and cleaning the latter, to prepare them immediately for the ovipositing of the queen. **4. Time for taking Condemned Bees.**—If the present brilliant weather continues, bees will continue to add to their stores. It is not advisable to drive, or manipulate bees at all, during very hot weather. A fortnight hence will be soon enough to take condemned bees. **5. Making Three Colonies out of Two.**—You may do as you propose, and may succeed by taking

three or four frames from each colony, and of these, with an additional queen, forming a new colony. We should prefer, however, to keep two strong colonies to three moderate ones, and to extract from the outer frames the surplus honey not required for wintering.

**M. H.—1. Sparrows.**—Sparrows, when numerous, are very destructive to bees, especially during the breeding season, which lasts nearly the whole summer. They will make several visits to the hive per minute, carrying off the bees to their callow nestlings with great rapidity, also dexterously seizing them on the wing. Destroy, repeatedly, all nests near the apiary; shoot and trap them. We have found a dead hawk, suspended from a branch of a tree near the hives, with out-stretched wings, an excellent scare. A living one would, no doubt, be more effective. **2. Bee-keeping Remunerative.**—To render bee-keeping remunerative, neither pains nor labour must be spared, and, as in all other pursuits, a considerable amount of experience is required. There is no 'royal road.' With intelligence and perseverance it may certainly be made remunerative. **3. Section Honey.**—This is the best honey season during the last eight years, and at present the market is rather overstocked, but neatly-wrought sections, exhibited in an attractive form, will always command a market. The public require to be educated to distinguish pure English honey from the adulterated syrups sold under the name of honey. You will, doubtless, hear from Mr. Moyle in due course, but at present we can well understand that he is overwhelmed with correspondence. Why force all the honey upon the market at once, especially during the present wax of intense heat? If carefully stored, it may be kept for an almost unlimited period. You should become a member of the British B. K. A. The 1-lb. sections are fetching from 1s. to 1s. 2d. each. The best have been sold as high as 1s. 6d. each. **4. Excitement of Bees.** The excitement, fanning, and shaking of the bees, was probably caused by the entrance of strange bees to the hive, and the bees which uncapped the cells were robbers, without doubt. When honey is coming in freely, bees will not always defend their hives, especially black bees, and more fratricide takes place than is generally supposed.

\*.\* The discussions on Messrs. Cheshire and Hehner's papers, which will be provided by the Literary Department of the Association, have not yet reached us.

**BRITISH BEE-KEEPERS' PRACTICAL NOTE BOOK.** By THOMAS W. GOWAN, F.G.S., F.R.M.S., &c. Crown 8vo. boards, 1s.; postage 1d. Indispensable for every Bee-keeper. Published by J. HECKER, Kings Langley; may also be obtained of all Hive-dealers.

**CHARLES T. OVERTON,**

First Class Expert of the Sussex Bee-keepers' Association,

**THREE BRIDGES, SUSSEX,**

Bees to call attention of all Bee-keepers to his

**NEW STOCK OF BEE-KEEPING APPLIANCES for 1884,** and hopes to be favoured with their support.

Sheep and Bounce Mats, and other Presses, awarded at Brompton, Knightsbridge, Hyatt, and other Shows, for the Best Hive, Bees, Smokers, Sippers, Extractors, Comb Foundation, &c.

Orders can now be booked for Prime Stocks, and Swarms, of ENGLISH, LIGURIAN and other Foreign BEES, for early spring delivery; also Imported LIGURIAN QUEENS.

**SPECIALITIES.**

The 'COWAN HIVE,' and Extractors; Bingham Smokers, the best in use; Sippers; Honey Racks; Comb Foundation, American 2-lb. and 1-lb. Sections; FLAT TOP STRAW HIVES, with hole in top for feeding and sipping, 2s. each; Crates of 18 1-lb. sections for Straw Hives, 5s. each, complete.

Questions on Bees and their Management answered by return of post, 3d. stamps. Send 7d. for Modern Bee-keeping, 1s. 8d. for Complete British Bee-keepers' Guide. Catalogue free on application.

**DR. PINE'S**  
**Registered Removable Metal Frame Ends.**

*Prize Medal, B.B.K.A., 1882; and numerous other Prizes.*

**B**y the use of this valuable invention the making of Frames is simplified. No metal runners are required, all systems of frames are rendered interchangeable, and propolization is reduced to a minimum.

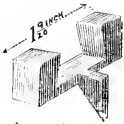

Unfortunately, as is the case with all inventions of merit, numerous substitutes are being introduced under the name of 'improvements.' But there is not one of these so-called 'improvements' which does not possess defects from which the original invention is free.

It is, therefore, absolutely necessary when ordering Hives to specify that the Frames are to be fitted with 'DR. PINE'S ENDS,' and with no others. All Hive-makers will supply Hives fitted with them, and generally without extra charge, the small cost being saved in diminished cost of labour.

Price of the Ends, 1s. per doz. or 10s. per gross.

**DR. PINE'S**  
**Woven Wire Veils.**

*Prize Medal, B.B.K.A., 1879.*

Do not confine the breath, do not obstruct the sight, and cannot be blown against the face or ears.

Price 2s. 6d. each.



**DR. PINE'S BEE-KEEPERS' LOTION**

Is the acknowledged Remedy for Stings, especially for removing the subsequent inflammation. Price 1s. 6d. per bottle.

*The above Inventions may be obtained from*

Messrs. NEIGHBOUR & SONS, Regent St. & Holborn, London; and from all respectable Dealers in Bee-keepers' Requisites.

*Dealers may obtain Wholesale Prices from the Inventor,*  
**Mr. F. LYON, 94 Harleyford Road, London, S.E.**

CATALOGUES FREE.

**Simmins' Hives, Crates, & Sections.**

'FORTRESS HIVES.'

Association 'Standard' Bar-frames, 1s. doz.

J. H. HOWARD, Holbe Apiary, PETERBORO'.

1887

**LAST DAY OF ENTRY, 30th AUG. 1884.**

**DERBYSHIRE BEE-KEEPERS' ASSOCIATION.**

PRESIDENT - - THE DUKE OF DEVONSHIRE.

The THIRD ANNUAL EXHIBITION of HIVES, BEES, HONEY, and APPLIANCES, used in Modern Bee Culture, will be held in the Show Ground of the DERBYSHIRE AGRICULTURAL SOCIETY, at DERBY, on WEDNESDAY and THURSDAY, Sept. 10th and 11th, 1884.

Apply for Prize Lists to Mr D. COOPER, Hon. Secretary, Normanton, Derby.

**BEE VEILS.** Improved with Wire Gauze Fronts, or with Silk Brussels Net. Post free 18 Stamps. Address B. DIXON, Papworth-Everard, St. Ives, Hunts. (59)

**E. M. HART & CO.,**

**The LONGSTOCK HIVE Manufactory,**  
STOCKBRIDGE, HANTS.

**SPECIALITIES:**

HIVES, complete, from 6s. SECTIONS, V-cut, in 6 sizes. FOUNDATION, Flat, or natural based.

CLARK'S COLD-BLAST SMOKER. 'Far and away the best Smoker.' 3s., post free.

HART'S SIMPLEX FEEDERS. 'The easiest and best to manage.' 1s. 6d. each, 15s. per dozen.

THE 'SWANMORE' SECTION CRATE. 'The most perfect Crate made.' (60)

The Trade supplied. Price List on application.

**ROYAL**

**Manchester, Liverpool, & North Lancashire**  
**AGRICULTURAL SOCIETY.**

GREAT HONEY FAIR and GRAND SHOW of HIVES, BEES, HONEY, and APPLIANCES, under the management of the LANCASHIRE and CHESHIRE BEE-KEEPERS' ASSOCIATION, will be held in the SHOW GROUNDS of the above Society, at STOCKPORT, on THURSDAY and FRIDAY, SEPTEMBER 4th and 5th, 1884.

MANIPULATIONS WITH LIVE BEES.

INTERESTING and INSTRUCTIVE LECTURES will be delivered each day, at 12 and 2 o'clock, by J. P. JACKSON, Esq., Editor of the *Bee-keeper's Record*.

**PRIZES.**

HIVES and BEE APPLIANCES—£6 2s. 6d., and Two Silver and One Bronze Medal of the Agricultural Society, and of the L. and C. B. A.

HONEY—Money and Certificates.

ENTRIES CLOSE AUGUST 27TH.

*Rules, Schedules of Prizes, Entry Forms, and all Particulars may be obtained on application to—*

**J. M. GIBBS, Hon. Sec. L. & C. B. A.,**  
**49 MOORFIELDS, LIVERPOOL. (80)**



# THE BRITISH BEE JOURNAL

Communications to the Editor to be addressed to 'STRANGEWAYS' PRINTING OFFICE, Tower Street, St. Martin's Lane, W.C.'

[No. 153. VOL. XII.]

SEPTEMBER 1, 1884.

[PUBLISHED FORTNIGHTLY.]

## Editorial, Notices, &c.

### 'BEGGING THE QUESTION.'

Mr. E. H. Bellairs, the excellent Hon. Secretary of the Hampshire Bee-keepers' Association, has asserted that we have dealt with the 'Liverpool Schism'—*well, too vehemently*. An old County Secretary, on the other hand, is of opinion that we have dealt with the aforementioned schism—*well, not a whit too vehemently*. Did any one ever hear of an editor who could please all his readers? 'Well, hardly ever!' to borrow from the libretto of 'H. M. S. Pinafore.'

The exact amount of *vehemence* with which an evil should be denounced must always be a matter of opinion, and the editor of any journal, who from the extent of information at his command is likely to be as good a judge on this point as his critics, must decide this question for himself, and accept all the responsibility.

There are times in our opinion, when soft words are unavailing, and are regarded only as indications of weakness. At such times vehemence becomes a necessity, if an impending evil is to be averted. When two antagonistic forces are advancing upon one another, a collision is inevitable, and, in our opinion, the sooner it takes place the better. If the cloud no bigger than a man's hand is to develop into a hurricane, it is a relief to have the hurricane over as quickly as possible. The bill which precedes the thunderstorm is the most trying form of *suspense* in the world. Nothing can well be done until the thunderstorm is over.

Timid counsellors have exclaimed, 'Why advertise the *Record* by taking any notice of it?' We have no objection to the *Record*, and no objection to advertise it. Until the present editor took it in hand it was a useful and practical little periodical. It was only when a series of attacks upon the British or Central Bee-keepers' Association were commenced in it that we felt it our duty to expose the object with which these attacks were made, and to call upon its editor to verify the malicious and unfounded charges which he was bringing against the Central Association. Each fresh attack only serves to bring out more clearly both the *object* and the  *motive* of the attack. The *object* is to abolish the Central Association. The  *motive* is that its place may be filled by some powerful County

Association. The fallacy upon which the abolitionist arguments are founded is that known to logicians under the name of '*Petitis Principii*,' or, as it is commonly called, '*Begging the Question*.' We will draw the argument out into the form of a syllogism, that our readers may appreciate it fully:

All Associations which have failed should be abolished.

The Central Association has failed. [Therefore The Central Association should be abolished.]

We deny one most important premise in this syllogism, viz., that the Central Association *has failed*, and I we call upon the editor of the *Record* to prove this.

Let us expose this same fallacy in another form. In the last number of the *Record* we find the following statement:

'The management of the Bee Department at the Royal Agricultural and other shows being a failure under the present arrangements, should be handed over to the County Associations.'

Let us reduce this fallacy to its syllogistic form:—

The management of the Bee Department of all shows which has failed shall be handed over to some County Associations.

The management of the Bee Department at the Royal Agricultural Show has failed.

[Therefore The management of the Bee Department at the Royal Agricultural Show shall be handed over to some County Association.]

To *what County Association?* we would ask. The Royal Agricultural Show is to be held at Preston next year. Preston (as our county maps inform us) is a town in Lancashire. It is to the *Lancashire* Association that the management of the Bee Department at the next Royal Agricultural Show is to be handed over.

The Council of the Royal Agricultural Society would have to be consulted before such a step (as our contemporary suggests) is taken, and we are assured that they continue to approve of the way in which their Bee Department is managed.\*

\* A correspondent some time since informed us that the management of the Bee Department by the Secretary of the Lancashire and Cheshire Association at the Agricultural Show held at Preston during the Guild Festival two years ago was 'a perfect muddle.'

## A HONEY COMPANY REQUIRED.

Having recently been privileged to attend a meeting of the secretaries of the Western Counties of England, we had the opportunity of ascertaining through them the requirements of the numerous bee-keepers in those parts. From fertile Dorsetshire and from humid Cornwall there was but one opinion of the extraordinary honey crop with which they had all been favoured; and there was one earnest cry from all of them: What was to be done with, where was the market for, the produce of their harvest? After satisfying the local demands there would be left on their hands a larger amount than they could possibly require for home use. They appeared to have little hope that local depôts could be opened for the disposal of their honey, but a very general desire was expressed that the Central Association should make an onward movement and give assistance to the counties in this matter. And this desire is iterated and reiterated throughout the kingdom.

During the year 1883 the Central Association on several occasions discussed the advisability of obtaining premises suitable for a bee-keepers' club, the holding of meetings, the library, honey-market depôt, &c. This proposal was put before the members of B. B. K. A. at the annual meeting, but was rejected by them. This has since been the cause of much regret; and we believe that had the members been able to anticipate the fruitful honey season in which they are now rejoicing the decision would have been the reverse. The Rev. V. H. Moyle has succeeded in establishing a depôt in Reading, and is exerting himself to do the same in London, Edinburgh, and Dublin. Single-handed he has effected much, and has discovered outlets and utilities for honey which a few years ago we could hardly have ventured to anticipate; but at present we are only on the verge of the possibilities of the utilisation of honey. Depôts, however multiplied, would not, we think, suffice for the sale of so large a quantity as has been produced this season, or as may be produced in future seasons. We require further to develop markets in our various localities. Honey should be sold by all grocers and confectioners, at such prices as would command a ready sale, and should be packed in a presentable form; more than three-fourths of the honey produced by the British bee-keeper is not prepared in a suitable form to commend itself to the public eye. Something beyond depôts in our large towns is required to carry forward this trade. The desideratum appears to be the formation of one or more Companies, composed of the leading honey producers—men of integrity and position, of business habits and skilled experience in the speciality they have to deal with, who would command the confidence both of the producer and the consumer. When the present and the future of bee-keeping are considered, the desirability of such a Company becomes daily more apparent and urgent. Owing to foreign competition in corn a larger amount of land is being laid down every year for fruit and pasturage, and this, as a consequence, must increase the supply of honey. The County Associations are

becoming more energetic and warming to their work, new bee-farms are being established, fresh fields are being opened up. For example: North Wales has no sooner been explored by Mr. Oswald Lewis, secretary of the Carmarthenshire B. K. A., than he pronounces it to be 'the grandest bee country he has ever seen.' We have before us a letter from a bee-keeper in Thirsk, Yorkshire, where, he says, no Association has penetrated and no expert has been seen: he says, 'It is a grand white clover country,' but that they 'cannot find a market for the honey when it is produced.' And the echo of this is heard from all parts of the United Kingdom.

In the meantime we would advise bee-keepers not to expect to be able to dispose of their honey all at once; the honey harvest is scarcely over; honey will keep if properly packed. It will be to the producer's interest to keep back a portion of his store, to watch the honey market, and not to overstock it at the present time.

## THE PRESS AND BEE-KEEPING.

Nothing is more indicative of the firm hold bee-keeping is taking of the public attention than the numerous notices of it which have recently appeared in the press, not only in the metropolis but in the provinces. Almost every day during the past month letters or editorials on bee-culture have appeared in the *Times*, and the consequence has been that a knowledge of the B. B. K. A., and its work, has been disseminated far and wide.

On the 7th August appeared in the *Times* a very interesting article on 'British Bee-culture,' calling attention to the importance of bee-keeping as a profitable employment for agricultural labourers, and the unsatisfactory manner in which it is carried on amongst that class. This article was commented on by Mr. A. F. G. Leveson-Gower, who, we think, rather ostentatiously signs himself 'member of the British Bee-keepers' Association.' We have our doubts whether he has a right to the membership of that Association, his name not appearing on the list of members since the year 1876. Mr. Leveson-Gower is known to bee-keepers as the translator of the 'Manual on Rational Bee-keeping,' written by M. de Ribeacourt, formerly president of the Société d'Apiculture de la Suisse Romande. We do not think, however, that either the work or the hive that it specially recommended have found much acceptance with the bee-keeping public. Mr. Leveson-Gower is evidently not aware of the extent of the work of the Association amongst the artisan and labourer classes. He has taken his stand on the bank, while the stream has been rolling steadily onward. He has little knowledge of the awakened interest taken in bee-keeping by cottagers.

The letter of Mr. Leveson-Gower has, however, proved of service to the cause; it has been the means of bringing to the front two well-known bee-keepers, the Hon. and Rev. H. Blyth and the Rev.

J. Lingen-Seager, who have ably vindicated the Association and have clearly demonstrated the good work which has been achieved by it. Mr. Seager thus concludes his letter, confining his remarks to that of which he is the most conversant,—the work that is being done by the Herts Bee-keepers' Association:—

'Local shows are being held every day all over the country at the best centres of communication. The Herts Association has already held one at Hitchin in connexion with a Sunday adult school horticultural show, and another at Moor Park, and has given prizes at the Buntingford Cottage Flower Show. These places are in the midst of agricultural villages. I have been to a number of these shows this year, and have been struck by the numbers of labourers, both men and women, who showed very great interest, not only in the honey exhibited, but in the manipulation of the bees themselves. In the spring of each year all the best county associations send round an expert to visit each member (in Herts the labourers' subscription is 1s, and the artisans' 2s. 6d.) to help and advise. A copy of each issue of the Journal is sent to every member. A large number of experienced bee-keepers in various villages kindly act as voluntary advisers, and are always ready to give assistance at any time in the year. Many of these are artisans and working men, who will, in my humble opinion, do more to remove prejudice, and by example and teaching induce others to "reform" and keep bees profitably, than the writing of manuals and introducing cheap hives. Practical lectures, entrance free, have been given this year in over thirty places in Hertfordshire alone, at which labourers and their wives were specially invited to attend. The bee tent is sent to a large number of cottage and other flower shows. The county is divided into twenty-six districts, in each of which resides a district secretary, whose duty it is to communicate with the hon. secretary of the Association upon all matters of interest in his neighbourhood. That much needs yet to be done I am fully aware, but I do not despair of success; and I fully believe that in a few years bee-keeping will be established as a national industry, if it may not be said to be so even now.'

#### TO COUNTY SECRETARIES.

The Rev. V. H. Moyle informs us that he is ready to supply simple boxes for county secretaries or any others, for annual bee shows, or apicultural or horticultural shows. The boxes contain a number of tins of Huntley and Palmers' Honey Drops, Mr. George's Honey Confectionery, Cardwell's Honey Medicines, also Honey Jujubes, Honey Beverages, and other honey specialities. These being supplied at wholesale prices can be sold at the show at retail prices, and so a profit is left for expenses of carriage, &c., besides forming an additional novelty, and a step forward in bee-culture.

#### PEEL TESTIMONIAL FUND.

A full statement of the amounts received on behalf of this fund will appear in our next issue including those received by Mr. J. P. Jackson.

#### WARWICKSHIRE BEE-KEEPERS' ASSOCIATION.

We hear there is every prospect of this season being their best County Show, entries being very numerous, and that the prizes will be distributed after the agricultural dinner by the Mayoress, Mrs. Hodgson, assisted by Lord and Lady Leigh and others.

#### USEFUL HINTS.

Another month of glorious weather, enabling the fruits of the earth to be gathered in both by men and bees, must fill all hearts with thankfulness to the Great Giver of all good things, and we trust that the hint contained in our leader last issue that at every harvest thanksgiving honey may be found among the offerings will be universally acted upon. Seldom does it happen that so extended a period of honey-gathering as that of this year is vouchsafed to us, enabling the bees to gather from the fruit-blossoms, the clover, and the heather. With the advent of September, the season is at an end, and bee-keepers may rejoice together while comparing notes on their respective gains. While, however, the generality of bee-keepers are in this happy state, there are unfortunately some whose bees, having been affected with *Bacillus alvei*, have done no good, but have either dwindled or remained stationary, and produced no surplus. To these unfortunates the past month will have brought consolation, thanks to the labours of Mr. Cheshire; and now is the time, by following his instructions, to get rid of the disease and get their stocks in a healthy state for the winter, with the certain prospect of next year finding them freed from all their troubles.

**ALUMINUM TREATMENT OF HIVES INFECTED WITH 'BACILLUS ALVEI.'**—As will have been seen from Mr. Cheshire's paper, it is necessary that the bees be forced to take the medicated food. Therefore, all the honey should be extracted, the bees crowded on to as few combs as they can cover, and fed with it. When honey was to be had, the bees would naturally refuse the phlegm just as a child who had access to the jam-pot would refuse a spoonful of jam with a powder in it. But now there is not the same facility in getting them to accept it. The honey extracted from the combs may be thinned out, medicated, and fed back to the bees. Reduce the entrances, and keep warm; act, indeed, as if stimulating in spring. As the bees increase, add a frame at a time in the middle of the brood-nest. By continuing this treatment, the worst case will become healthy, and when the time arrives to pack for the winter, will be strong and full of young bees.

**THE TREATMENT OF INFECTED STOCKS** must be based on the same principle, but as we cannot remove the stores we must force the bees to take the cure by turning up the hive each day and pouring the medicated food between the combs. This will stimulate the queen to lay; and to give her room, the diseased brood will be removed, and will soon be replaced by healthy grubs. Some readers of Mr. Cheshire's paper will be going into elaborate calculations to arrive at the proportions, but by his forethought all that trouble is saved by procuring 'The Cheshire Cure,' which is accompanied by such simple directions as no one can mistake.

STORES must now be removed, if not already done, or much of the honey will be carried down to the stock-hive.

**ENTRANCE FEEDING.**—This may be done for the last time if the honey is greatly wanted.

**FEEDING.**—As hinted last month, breeding will now naturally cease, but should be prolonged for a short time by gentle feeding, so as to have plenty of young and unmown bees to survive the winter and start the young brood in spring. Feeding for stores should be completed by the end of this month, and as much work towards the preparation of stocks for winter got on with as possible.

**CONDEMNED BEES.** These must now be looked after and taken. In very few districts will cottagers keep them after the first week in September, and if left too long they will be 'put down.' Read the article in our last, and specially bear in mind that the success of them in the spring depends upon the absence of work which they are called upon to perform now. If you have not acted upon our hints and got combs ready for them, rob your existing stocks of a few and let them replace them, rather than put the labour upon the condemned ones.

ROBBERS will be very troublesome, and will soon find out weak stocks and destroy them if not prevented. Be most careful to cover up all feeders, so that no bees can reach them from outside, and not to spill food about, or leave it or waste combs anywhere where bees can find them.

WASPS.—Continue to wage war against these pests. By destroying nests now, the production of thousands of queens, each of which may form a fresh colony in the spring, is prevented.

SEASONABLE HINTS TO COUNTY SECRETARIES.—Make a note of all Flower Shows, Cottage Garden Society's meetings, &c., held in your districts, and try to arrange for a visit of an expert and bee-tent next season.

EXTRACTED HONEY FOR COMPLETION OF SECTIONS.—In the course of a discussion upon Mr. Hehner's paper at the Conference, Capt. Campbell took exception to our 'hint' of 1st July on the use of 'extracted honey' for completing sections. The Chairman said if Capt. Campbell would quote chapter and verse from the *Bee Journal*, no doubt he could be satisfied, but this Capt. Campbell did not do. He misquoted the words used, which were, not 'pure honey of course,' but 'extracted honey.' It often happens that we have to extract honey from the stock hive to give the queen room for egg-laying, although we do not want extracted honey; while at the same time, we have supers, which we do want, unfinished by reason of a change in the weather. Our suggestion was, that this extracted honey, 'pure honey of course,' as the Captain puts it, might legitimately be used for the completion of the supers for sale. We expressly excluded such a method from the production of supers for competition. If Capt. Campbell had, as he suggests, bought honey at 6d. per lb., and let his bees store it in sections to sell at the price Mr. Moyle quoted, 9d. (not 1s. 6d.) for a one-pound section, he would have found it commercially as well as morally a failure.

### BEE-KEEPING GOSSIP.

\*Mel' sapit omnia.

The idea of fruit and bee-farming is extending. I hear Mr. Blow has to start a large concern next spring for a farmer who has planted a large tract of his farm with fruit—and in Herts, too, of all counties. The same enterprising manufacturer has another large order for Hunts from a farmer, who, although he does not grow fruit largely, considers he might as well gather as 'waste the sweetness on the desert air.'

Spite of all the good reports I met a grumbler yesterday. 'Can't understand it,' said he, 'you have so much honey, and I cannot get scarce a pound; they won't take to the supers, and are just now nice and strong, but the supply has failed.' I told him we must order a special late glut for his benefit.

On all hands the cry is, 'What shall I do with my honey? Where can we sell it?' I have a bit of news for Mr. Moyle, if he get any offers of inferior honey not fit for domestic use. An old farmer tells me they used to mix honey with medicines to make drinks for cows; but of late years they use treacle instead, honey being too dear, but far superior. Can't we tempt them to return to the good old ways?

We must have lots of foul-brood about—I beg Mr. Cheshire's pardon, '*Bacillus alvei*'—or many bee-keepers must be attempting to prevent an outbreak. A dealer that advertises phenol tells me he sells immense quantities of it.

I don't take all in that old women bee-keepers say, but here is a bit I got to-night. I drove her bees for her for the fifth autumn, and remarked how few comparatively there were of them, although her skeps were full of honey; her answer was, 'Few bees much honey, many bees no honey!'

How many of us read the 'Echoes' attentively, I wonder. Here is a poser put by our friend John Walton, 'How to deal with skeps that are loaded with honey on the let-alone principle.' I have driven several this year already, with every cell sealed full of stores, except a small patch about the size of the palm of your hand on one comb perhaps, and few bees. What will such stocks be good for in spring is the question.

A friend in bonnie Scotland tells me he has a hive built up for extracting that weighs over 2 cwts. and crammed full of bees! Not amiss that.

How many people complain about their gardeners not interesting themselves about their bees! As a class, they are not slow to adapt themselves to circumstances, and I doubt not will soon find they will have to add a knowledge of bee-keeping to their many other attainments.

Third-class certificates will be useful to them, I judge. It certainly would be no small recommendation to such seeking a situation to be able to produce the parchment.

The press is busy at present in our interest. Mr. Lovesson-Gower writes to the *Times* and gets an answer from one of the Central Committee most entitled to speak on a question of bee-keeping and the agricultural labourer—the Hon. and Rev. H. Bligh, and a hon. sec., who in speaking of what the County Associations are doing to promote bee-keeping amongst the labourers, hides his own personal services in praising others with good grace—the Rev. J. Lingen-Seager of Herts. Besides this there have been articles in the *Daily Telegraph*, *Standard*, *Liverpool Mercury*, and a host of others.

I was going to say a word about your 'Useful Hints,' but Mr. Buller, I find, has taken the matter up; so while he has been doing as he was bid, I have been doing ditto, and here is the result.

On page 275 I read, 'The first thing to do is to smoke all, and to close all the entrances with a wisp of grass, whether to be taken or not.' Well now, I have driven a few lots of condemned bees—a few hundreds, I may say; but I never tried closing entrances but once, and then only those I had to take, but never no more. Oh, no!

I drove one lot all right, but when I lifted the second skep there lay the bees on the floor-board 'suffocated.' I cleared the combs and found the third ditto; but in a few moments the 'suffocated' bees that came from the second lot woke up, and not having gorged gave me notice to bring their stores back, or take the consequences. So not preferring the former I had to submit to the latter, and retire to a neighbouring hedge, and extract—but not honey. And, worse luck, I lost the chance of teaching the cottager my 'more excellent way.'

So I jog on now my old slow jog-trot way that the old-fashioned people used to recommend in *Modern Bee-keeping* and the *British Bee Journal*, and use my eyes, as I don't get them bunged up. But then I never was but a slow one, and only an—AMATEUR EXPERT.

### THE CHESHIRE TREATMENT OF BACILLUS ALVEI (FOUL-BROOD).

The interest evoked by my discoveries in relation to the most-dreaded malady to which bees are subject has, as I imagined it would amongst bee-keepers, principally centred around the method of cure. I trust, however, that the scientific bearings of the question will have sufficient attraction for many readers of the *British Bee Journal* to induce a very careful perusal of another communication of mine, which I fancy will be found in this issue,\* announcing the curious and possibly very important discovery that many oddities and puzzling appearances noticed amongst bees, are distinct diseases caused by four or possibly five species of bacilli, new to science; but my object in now writing is to encourage and stimulate those depressed by the presence of the plague,

\* This communication has not yet reached us.—Ed.

by asserting—with a positiveness which, for reasons which will presently appear, I did not think it wise to assume at the Health Exhibition—that foul-brood, bacillus disease, in its worst forms and most malignant types, is absolutely subject to my method of treatment. The ability to make this declaration without any reservation affords me the keenest pleasure, repaying me for much of the exhausting labour necessarily connected with the investigation, for I—in imagination—already see the day when anxiety about contagion will not only be put aside, but that foul-brood itself will become a curiosity; and this, indeed, must be unless bee-keepers are more apathetic than their past history seems to testify.

While examining the great number of specimens of infected combs sent me by friends and strangers, two points received to my mind demonstration:—1st, That Dzierzon is in error in asserting that there are two kinds of foul-brood—one, mild, chiefly affecting the larvae; the other, malignant, making its main impact upon the chrysalids. There is but one kind of foul-brood. The same bacillus causes all, and, contrary to Dzierzon's idea, that form of attack which strikes the larvae early is the more active and the more difficult of treatment, if there be a difference; and that if this early falling of the brood be caused by disease lurking in the queen she will, so far as we as yet know, need to be supplanted. 2nd, That, although all cases are produced by the bacillus which I have called *alecia*, and so far are identical, yet the spores are at times more robust and virulent than at others. Those who have given any study to germ diseases know that this has not only been observed, but actually made of practical use (*vide* my communication referred to).

Amongst the specimens forwarded, two or three when examined microscopically indicated, or seemed to indicate, great activity, and the apertures from which they came had in each case been ravaged by the scourge from end to end. In one instance the colonies, running very nearly if not quite to three figures, had not a soul one amongst them; in a second, thirteen hives were dying out in rottenness; and here, also, not one had escaped.

The stock supplied to me by the kindness of Mr. Mills came with a sufficiently bad reputation; the malady had in a very short time snuffen, in an apiary of about twenty, every stock save three. (I speak here under correction; I have no notes, and my memory may be in fault.) I regarded it as a fair typical case of advanced foul brood, quite beyond the reach of ordinary curative measures as they have been usually advocated. The manner in which the disease in this instance died out before my treatment is now matter of history, but I had not, at the time of the Congress, tried conclusions with the malady where it had been most relentless and where it had worked the most devastating effect. Although I felt confidence that the disease was in all cases alike, and so must in all instances be amenable to the same methods, yet I could not rest until the experiment had been tried; and so, having secured three combs from the larger apiary previously referred to, stipulating that they should be the worst that could be found, and one from the second saturated with disease, and having possessed also for eighteen days a comb given me by Mr. Mills as a specimen of what the disease could do, which comb had become rotten, mildewed so that half the cells could not be seen, and had little maggots feeding on the bodies of the decaying larvae. I determined with these to make a stock.

On the morning of Wednesday, August 6th, these six terrible combs were placed in a hive and stood in the position of a good colony, which was removed to a new stand; the queen having been found, was popped in under the chaff-tray (which I use instead of a quilt) between the disease-laden combs. The poor foragers, with heavy loads and light hearts, began dropping in numbers upon the alighting board; but the confidence

with which they ran in gave almost ludicrous contrast to the dismay with which they instantly reappeared. Circling in the air and taking their bearings, they tried again and again to discover what had happened, when in sheer rebellion they refused to enter, and clustered at night thickly on the outside of the hive, buzzing and fanning with a noise audible at many yards distance. The following morning saw no improvement, and at about eleven o'clock they went off boldly and settled as a swarm in a cherry-tree, in the very spot to which every natural swarm of mine has this year betaken itself. Having hived them in a skop, I was about to return them when they again took wing and gave me a journey into a neighbour's garden. 'Prudence is the better part of valour,' so a concession was made, and one of their own combs divested of bees and containing mostly unsealed larvae was given to them at the front of the hive. They were now returned and very many entered, but a big lump remained clustering about the porch. I really felt sympathy for the worried little insects, for as a lady said in a letter to me a few days since, 'I love my bees.' A point was to be proved, however, and so temporary discontent could not be considered.

Early next morning I began by pouring my medicated syrup into their combs. This they rearranged, and in doing so started the cleansing process. Day by day, at an early hour to prevent robbing, I fed as described, while the improvement became marked. Medicated syrup which at first would be utterly refused unless poured into the combs, will often after a few days be accepted freely from a feeder in the usual way. But in treating all cases such management must be adopted as will secure the using of a liberal allowance of the remedial agent. Noticing that the syrup was freely taken at the sixth morning, I determined to pour into the combs no longer; but made an impromptu feeder, with which I should be able to watch the movements of my small assistants. A shallow tin box about 3 ins. by 6 ins. was supplied with strips of very thin wood, which were stood on edge, and spaced apart by little uprights which gave room between for the bees to enter, after the fashion of a Gray's feeder. This was placed behind the dummy; the latter being raised sufficiently to allow the workers to pass beneath it. Into this box now the food was poured, the bees continually carrying it into the combs. As the weather was dry the syrup was given thin, and the box was never allowed to become empty. Eggs continued to be laid rapidly, the stock became active and content, all smell vanished, and to my joy the brood was raised in the so previously deplorable combs was almost perfectly healthy from the first. Most, however, of the grubs on the lower edge of the added comb took the disease, and passed through the first well-known stages; but they all disappeared, being undoubtedly carried out by the workers. This circumstance supports most completely my theory as to the means of infection, as given in my paper at the Congress. Three or four sealed cells still remain, which I know have the remains of dead grubs. When their covers break, the bees will clean them out; but with these exceptions the hive is now—August 23rd, seventeen days after commencing operations—as perfect in all respects as could be desired, while every dead grub, all coffee-scented matter, and dried putrid scale, is most completely removed.

The *Bee-keepers' Record* says, in referring to my paper, 'Whether phenol is really a specific for foul-brood time alone will show, but we urge our readers to give it a thorough trial.' I reply that all that could be done to prevent phenol succeeding I have done. I have heaped up difficulties; given bees such combs as I venture to say they have never received before in the history of bee-keeping; secured the most virulent type of the disease I could discover, and yet in seventeen days a most perfectly healthy aspect is presented, and the bees, with brood in their six frames, are hard a

work comb-building. I assert, with all the positiveness I can command, that phenol, upon my plan, is a specific, and only needs a careful and correct application. And, best of all, no loss is occasioned; the food given stimulates and strengthens, as well as restores health, and a smitten stock will, from the little extra attention it gets, soon become probably the best in the apiary. The notion, too, about infected hives is largely a delusion. Burning is sheer folly. Boiling is utterly useless, for it would not kill the spores, if such were present. Washing with carbolized soap is all sufficient. Cheer up! cheer up, dejected ones! Try your best, and the sunshine of new hope shall soon be yours. Having made great sacrifices in reaching my results, my disappointment will be keen if I am not seconded by the more intelligent apiculturists helping the helpless in driving the fell pest altogether from our midst, for this is the consummation devoutly to be wished.—FRANK R. CHESHIRE, *Acton, W.*

#### MR. CHESHIRE'S PAPER ON BACILLUS ALVEI.

(Read at the International Conference held at the Health Exhibition on Friday, July 25.)

The Chairman, in opening the Conference, said it was on a most important subject. Mr. Cheshire had, he knew, devoted a great deal of trouble to, and had spent a great deal of time and mental labour on, the paper he was going to read. He would say nothing with regard to what he anticipated from the paper, but to show the practical importance of the subject he would read a letter he had received from a cottage bee-keeper, and a portion of another from Mr. Cowan, who was now in Switzerland. The latter gentleman wrote: 'I particularly regret that I am not able to be present at the reading of the papers, as both the subjects are specially interesting to me. With regard to Mr. Cheshire's paper on foul brood, it will be very interesting if he can throw some light as to the cause of this disease, which seems up to the present, to be so deadly in the hands of many. It will also be a great boon if a simpler method of curing diseased stocks can be devised, and from what has appeared in the *Journal*, I see the remedy Mr. Cheshire proposes is not to cost more than 3d. per hive. This will be a great boon to bee-keepers. I have sent a translation to the *British Bee Journal* of a paper which appeared in the *Travaux de la Société Économique Impériale* at St. Petersburg, by M. D. Ossipow, of whom a Russian bee-keeper of eminence, M. Zoubaroff, says he is a bee-keeper of great experience. This gentleman thought of the idea of curing foul brood with camphor, and succeeded perfectly, even with stocks having the disease very badly. The process is so simple, and the cost so trifling, that I give you the process, so that any of those present can try it for themselves, and report upon it. The whole of the secret consists in giving the hive a lump of camphor (wrapped up in a rag about the size of a small walnut. This is placed on the floor-board inside the hive, and the foul brood disappears. Besides M. Ossipow, a number of other bee-keepers have tried the same remedy with perfect success. The bacteria of foul brood do not seem to prosper in a camphorated atmosphere.' The other letter was a simpler production, but it would perhaps speak more feelingly to the meeting, from a cottager at High Wycombe, in Buckinghamshire, who wrote: 'I cannot get rid of foul brood; nearly all my bees have got it, and I thought I had got rid of it. I don't think there are many free from it in this district. I shall have to clear right out I expect; only had two swarms. It makes me disheartened to keep trying. I hope Mr. Cheshire can cure it; it will be a blessing to bee-keepers. I have found it in Surrey, Hampshire, and Berkshire, and I have known thirteen places round me that have had it, some have lost all, others some. I should be glad to know how to stop it, for it has ruined me; and I fear others will lose

their bees, for some that I bought last year smelt so bad, I burnt them six weeks ago. All I bought last year I shall have to destroy this year.' Of course it was a very hard case for a poor cottager, who depended very much on his bees for his income, and who devoted almost all his leisure time to them. He only hoped Mr. Cheshire would be able to suggest an answer to those letters, and to tell them something which would be of value to the bee-keeping world at large.

Mr. Cheshire having read his paper (see p. 256), the following discussion ensued.

The Chairman, before inviting remarks on the paper, asked Mr. Cheshire for an explanation, in as simple a form as possible, of what Phenol was. A short time ago a discussion took place at one of the Quarterly Conferences held in the Board Room of the Society for the Prevention of Cruelty to Animals on this subject of foul-brood, and a gentleman present advocated the use of thymol. Nobody seemed to know exactly what that was until the gentleman himself stated that it was the essential principle of thyme.

Mr. Cheshire said there was a gentleman in the room who was far better able to take up this point than himself, and he would simply say in one word that phenol was a relative of those tar-products which had so recently attracted attention. It was closely allied to benzene, and was commercially associated with a great number of bodies to which bees had the greatest aversion; so that unless it were used in its absolutely isolated condition it would fail in its effect. If it were put into the brood-nest absolutely pure the bees would use it at once. It should be given to the bees as part of their food, and as it had a special affinity for, and was not destructive to, those micro-organisms which are the cause of the disease in question, it specially effected a cure.

The Chairman said he thought the meeting would now understand that phenol stood in some way the relation to tar that thymol stood to thyme.

Mr. Otto Hehner, as a non-bee-keeper, was afraid he could only appreciate the advantages which the discovery of Mr. Cheshire would confer upon bee-keepers, but he could say that a more thoroughly scientific paper he had never listened to. Step by step Mr. Cheshire had traced this disease, and he had shown that it was analogous to very many diseases which affected not only animals but human beings. Indeed, from our present standing-point of knowledge, every infectious disease was due to some organism, generally one of those *bacilli*; and Mr. Cheshire had succeeded in adding one more to the already long list of infectious agents. With regard to the use of antiseptic substances, of which phenol was one, in food, he could see no real objection to the addition to food of either salicylic acid or phenol in small quantities, neither of them would have any injurious effect; an argument against the use of antiseptics was that they were added to perishable substances to hide incipient decomposition, and of course they did not want such articles to be kept longer than they ought to be kept or would naturally keep. They wanted to have milk fresh from the cow, and not kept fresh by means of salicylic acid; and they wanted wine properly fermented and not kept. He quite agreed with Mr. Cheshire that when phenol was used as a curative it should be used pure. If the impure phenol were used, it would bring Mr. Cheshire's process into discredit on account of its variable effect and objectionable odour, which did not really belong to it at all, phenol being rather pleasant than otherwise, and that would be a test of whether it was pure or not. Only a pure substance, on which reliance could be placed, should be used for these purposes. There were very many other antiseptics which might be applied, like boracic acid, salicylic acid, and thymol; but phenol was the most powerful substance of its class. Many antiseptic agents were so poisonous that they could not be used with

safety. He would only add an expression of his thanks personally to Mr. Cheshire for the very valuable and interesting paper he had given them.

The Rev. Geo. Raynor said the subject brought before them by Mr. Cheshire was one of the very greatest importance. Although he had been a bee-keeper for many years he never had a single case of foul brood—at least, to his knowledge; but certainly some doubts had occurred to his mind during the reading of the paper as to whether two cases which he had had a short time ago of bees dying in an unaccountable manner had not arisen from that cause. The manner in which Mr. Cheshire had laid the matter before them could not be too highly spoken of, and he hoped they would hear something from gentlemen present who had more experience in the matter than himself.

Mr. Griffin (Secretary of the Devonshire Bee-keepers' Association) said that in the spring he had had to destroy nine stocks on account of foul brood, fearing it would spread to the neighbouring apiaries; as, having been away from Exeter most of the spring, he was unable to thoroughly test the remedy of salicylic acid, as recommended by Mr. Cowan; he also stated that the smell from the diseased stocks was very bad. As the stock showed slight signs of the disease, and being very strong with bees, he put a super upon them, and in three weeks after the smell from this stock was most offensive, and could be detected some considerable distance off. In six weeks he found that the smell was entirely gone, and that the section tray had been filled with fifty pounds of honey. He had not since examined the stock to see if the foul brood had disappeared. However, that was a very curious circumstance, which, perhaps, Mr. Cheshire would explain. In several of the stocks the bees had been trying to raise queen-cells; the queen-cells were there, but the bees were evidently not strong enough to throw off a swarm; some had wings and had died before they were nearly hatched, and some were dying in the cells. These circumstances seemed to point to the fact that something was evidently amiss with the queen, and that the bees were aware of this, and trying their best to remedy the evil. A gentleman told him lately that a cottager had been treating blue gum, by putting a few drops into the hive, and he said that the foul brood disappeared in a very short time, probably from the vapour arising from the gum.

Mr. T. B. Blow would be glad to hear whether Mr. Cheshire had tried the effect of thymol for foul brood. He had never been troubled with that disease, but he had tried experiments during the past two years with bees subject to the disease, and had found that thymol proved an almost perfect remedy when administered in food and also in the hive. He supposed the action of thymol would be extremely similar to the action of phenol, but of course he had not gone into the matter in the same scientific manner as Mr. Cheshire had done.

Mr. Lyon was able to inform the meeting that the 'blue gum' referred to by Mr. Griffin was the oil of eucalyptus or blue gum tree. There was a substance termed 'eucalyptol' extracted from this oil which was a parallel substance to 'thymol.' In the Exhibition building Mr. Squire had very kindly shown him samples of both. They were crystalline substances similar to camphor, with a very similar smell, and no doubt their properties were also similar.

Mr. Jesse Garratt (Secretary of the Kent Association), in confirmation of what had been said by Mr. Griffin, said that he had also found bees in diseased hives raising a great quantity of queen-cells.

The Rev. F. T. Scott might say with the rest of the speakers that he was exceedingly interested in the paper which Mr. Cheshire had read to them. If it proved successful the remedy would be a very great boon to apiarists. He could not say with Mr. Raynor that he had never suffered from foul brood, but he had certainly

never discovered it until last year, when he attributed it to the introduction of a Ligurian queen into his apiary. He found that two or three stocks had afterwards become affected with foul brood, and he was obliged to destroy them. He was so strong in bees in the spring that he thought he would leave the bees in the stocks, and he took away the queen in one and left the queen in the other. Those two stocks had prospered this year. The bees had increased very rapidly, and had given him one or two very good supers, but on examination the other day he found there were still some infection and symptoms of disease, and he was very anxious to know how to treat it. His idea was that they must be destroyed, although he found that Dr. Dzierzon, the great German apiarist, did not fear it; while the great Dr. Langstroth, the American apiarist, said that though they lost it in the autumn it reappeared in the summer.

The Chairman said that several gentlemen who had spoken had stated that they had never been troubled with foul brood; as the meeting had heard a great deal about a cure of the disease he would like to hear from some of the victims of foul brood to what extent they had suffered from it. He saw Mr. Martin present, whose letter he had read to them, and would be glad if he would kindly stand up and say what he had suffered from foul brood. The meeting would then be better able to judge of the importance of the cure. Mr. Martin had long ago been guaranteed, by the British Association of Bee-keepers, to be the best sample of a *Ligustica* cottage bee-keeper that they could find, and he lived in High Wycombe, a district which was sadly infected with the disease, for which they were trying to find a remedy.

Mr. Martin said that about seven years ago he introduced Ligurian queens into his hives. He never knew what foul brood was until then. He had about ten queens, and introduced them into some of his best stocks. The old members of the Association might know that he used to exhibit splendid honey, but as soon as he introduced the Ligurian queens the very first year he was attacked with foul brood. It began in the spring. He could not make out why his bees did not prosper, and he examined the hives and found a very bad odour from them. He wrote to Mr. Cheshire and asked his opinion and advice, and that gentleman gave him to understand it was foul brood from the sample that he gave him. He watched the infected stock, and though it dwindled down to nothing, there was some splendid honey in it. He gave seven stocks honey from that one, and every one of them had it. Then it began to spread, and last year he lost forty stocks from foul brood. He cleared again the last one last summer. However, he persevered again and brought seventeen more from a distance last year, which he brought to his apiary in the spring, and he found there were about ten of them had caught it again. He moved seven of them about a fortnight ago, and took all the honey away. He had come to the meeting to try and see if there was a remedy, and if there was anything that could be tried he would like to avail himself of the opportunity of using it. He had with him a little piece of comb which he would be glad to show to the meeting, and he would send any quantity of comb, bees, or queens with foul brood that they wished at any time.

The Chairman said they would very much like to have some of the comb.

The Rev. F. S. Selater said that in Buckinghamshire they are seriously infected with this disease, and he could certainly speak personally from the condition of his own hives. Mr. Cheshire had given excellent directions for using syrup medicated with phenol in a frame-hive, but it did not appear so easy to give it to the bees in a skep-hive, remembering that they must put the syrup into the cells and not give it through a feeding-bottle. He would like to know whether Mr. Cheshire could suggest any means of introducing it successfully into

skep-hives, where in many cases foul-brood was likely to exist undetected and without proper treatment. In this way the skep doubtless became in many instances a centre of infection, and its owner, in happy ignorance of the disease and its characteristics, might neither find out for himself nor allow others to ascertain for him what was causing his hives to do so badly. He thought it was most desirable that the British Beekeepers' Association should publish a small leaflet, specially designed for the use of cottagers, whether members of the Association or not, giving, in as plain words as possible, directions for using this new remedy of Mr. Cheshire's, telling them where the materials which they needed could be obtained, and giving them every information on the subject. If that sort of leaflet were circulated throughout the country they might get the old-fashioned skep-keepers to take the matter up and try thoroughly to get rid of the disease; but, unless energetic steps were taken soon he felt convinced that in many districts bee-keeping would decline very rapidly.

The Rev. E. Bartram said it did not seem quite clear to him that salicylic acid had proved a failure, and he would like to hear what Mr. Cheshire could tell them on that point. He regretted to say he had had foul-brood, and far too much of it. On his first acquaintance with Mr. Cheshire, he well remembered that gentleman coming to him full of the enthusiasm which still happily animated him. He had introduced salicylic acid and sprayed the combs, but whether the remedy corresponded with the result might be a doubtful question; he would hardly like to say that, probably that would be unfair to him, but still he thought that the results of using salicylic acid were in many cases fairly satisfactory. Mr. Cheshire in his brilliant paper had shown that he had gone through the question very thoroughly, but still before the British Beekeepers' Association undertook to publish any essay upon this question the subject should be more thoroughly investigated. Mr. Cowan had mentioned a paper in the letter put before them, a paper translated from the Russian, in which camphor was said to be an absolute specific. He hoped, in some form or other, the difference between those two substances would be pointed out to them, and why phenol should be so superior to camphor. If they could use camphor for this purpose it was quite clear they had only to put some camphor inside the hive, and they would have something which would at once prevent the disease. No doubt Mr. Cheshire would take up the point and give them some further information upon it. It was most important when they had their apiaries in a good condition not to buy driven bees. He felt convinced that he had introduced foul-brood into his hives by purchasing driven bees in the autumn, and his advice to beekeepers was not to purchase bees from outside unless they were sure of them, and to keep their stocks to themselves. If their stocks were quite free from infection they might then possibly escape the disease altogether.

Mr. Harveyson said that at Finchley he had cured a hive of driven bees by salicylic acid. Last autumn he found foul-brood in it, and separated the queen until all the brood was hatched out; he then uncapped all diseased cells and thoroughly sprayed the combs with salicylic acid, and the bees were now all right—though rather weak. About a fortnight ago he examined a hive for a friend at Finchley, and found it full of foul-brood. He took a frame of it to Mr. Cheshire, who examined it and gave him some of his remedy. He had found that by applying the remedy as directed by Mr. Cheshire, the bees were rapidly clearing out the diseased cells, and in some there was already healthy-looking young brood. He might say that the frame which he took to Mr. Cheshire he had put into his own hive, which he cured last year, and there were no signs of the foul-brood in

the comb now.\* He was sorry to say that there was a great deal of foul-brood around his neighbourhood, and that the bee-keepers would be very pleased to get rid of it.

The Rev. Mr. Wilkinson had seen one bad case of a foul-brood in a hive at Marlow, where the old plan had been adopted of isolating the bees and sprinkling the combs, and then returning them to the hives; but that was the only case which he had known of in his district in South Buckinghamshire. After what had been stated, he certainly would fight shy of driven bees. Among the large apiaries, those of Mr. Scott Murray, foul-brood was perfectly absent, as it was in other cases where apiaries were kept by gentlemen in the district. He could not say what the effect of keeping bees in slops was. He would like to have a prescription for the use of this phenol remedy. With regard to the case he had mentioned, the man of whom he had spoken had scarcely any honey in comparison with what he had had in former years, although he lived in the best district possible for producing it, the fields at the back of his house being a mass of bloom.

Mr. Athawes remarked that it should not go forth from the meeting that people ought not to buy driven bees, because if they had a cheap and easy cure, why should they not be bought? Mr. Bartram seemed to adopt a foregone conclusion that it was incurable, but if it was curable there was no objection surely to buying driven bees.

Mr. Dunman (Secretary to the Dorsetshire Beekeepers' Association) said he had only attended to learn the way to cure foul-brood should it appear in his district, but he had not yet heard of a case of the kind. If cottagers were to be told they were not to purchase driven bees, and that those were condemned bees, the cottagers would immediately destroy them, and it would be the worst possible thing to go forth from that meeting that people were not to purchase or use condemned bees.

Mr. Martin wished to know, from something which had been said, whether any objection had been intended to be made to the use of straw skeps.

The Chairman said not at all. Mr. Selater had only asked whether the remedy could be as easily applied in them as in bar-frame hives.

Mr. Martin was sorry if he had understood the matter wrongly, but he would only say that he had found the bar-frame hives were as susceptible to the disease as straw hives. He could refer to several cases where apiaries had been destroyed in which bar-frame hives were used.

The Chairman said the question was not in the least as to the relative merits of bar-frame or straw-skep hives; what they wanted to find was a remedy for the disease, whatever sort of hive it might attack.

A Visitor was not desirous of saying a word against straw-skep hives, but he could state that in his neighbourhood one case had been distinctly and thoroughly traced to the use of them.

Mr. Buller, with regard to the reference which had been made about driven bees not being purchased by beekeepers, said that during the last two years Mr. Blow and himself had, he believed, introduced 500 lots of driven bees into hives, and never once had they had a case of foul-brood, though the bees had been brought from all parts of the country. Many others—of course not driven bees—were from Italy, Carniola, Cyprus, Syria, and America, and all with the same result—no foul-brood.

The Rev. George Raynor would make the additional remark to what he had said before, that it struck him one of the most important points in Mr. Cheshire's paper was the possibility, or rather the fact, of imported

\* The piece of comb containing brood in perfectly healthy condition was handed to the Chairman.



queens introducing the disease of foul-brood. He had always believed that it could not possibly be introduced by queens. For twenty years he had introduced imported queens, and he never had a case of foul-brood, although two years ago he introduced about seventy imported queens. It had occurred to him whether his immunity from this terrible disease had not arisen from the application of the very remedy which Mr. Cheshire advocated, because he had always used, in preference to smoke, a weak solution of carbolic acid for quieting his bees. He never opened a hive without using it. With a long goose-quill he moistened the tops of the frames with it, and the bees ran down, dreading it quite as much as they did smoke. He was very careful not to disturb them more than necessary, and he thought the remedy was much preferable to smoke, because it did not produce confusion or disturbance to the same extent in the hive. When he had spare combs stored away for the winter, ready for use in the next summer, he always sprayed them with a weak solution of carbolic acid, and he had at times, of late years, used in the food of the bees the salicylic acid solution as described in Mr. Cowan's recipe. It was very probable that his immunity had arisen from his application of these two remedies, for although he had been in neighbourhoods where foul brood had existed around him, he never had a case of it himself. With regard to driven bees, he had very often strengthened weak colonies by their means, having added from twenty to thirty stocks every autumn; and he found that he had never introduced foul-brood by so doing.

Mr. J. M. Hooker had suffered considerably from foul-brood, but he was happy to say his apiary was now entirely free from it. Mr. Cheshire had mentioned his name as having visited the experimental hive at Aton. He was requested by some members of the Committee to inspect that hive, and to express an opinion as to whether it was a fair specimen of foul-brood or not, and he could distinctly say that the hive had been clearly suffering from foul-brood, as there were several frames in which there were foul-broody cells. He could say that it was going on very well at that time. He marked the frames which had still to be dealt with, and no doubt he should see presently that they had been entirely cured.

Mr. Cheshire said they were now all right.

The Rev. F. G. Jenyns said if he understood Mr. Cheshire's paper rightly, the only cure for this disease was that which he had given administered through the food; but if the only cure for it was by the food given to the bees, he could not quite understand how they heard from time to time of isolated cases arising in apiaries and yet being cured without that food being given. They had heard of fumigation and the use of camphor as remedies, but he did not understand at all how they could be remedies if the only remedy was to be administered through the food. He thought Mr. Cheshire's theory was excellent, and no doubt it was the true remedy, but he could not understand how those other theories could have had any foundation at all if Mr. Cheshire was right. They had heard about the queen-bees introducing the disease, but of this he himself was no judge, having never introduced them. He kept to his own, and had never taken imported queens. Nobody, however, had had more experience than his neighbour, Mr. Blow, in imported queens, and his apiaries were quite free from disease.

Mr. Henderson said it was very possible that what had been read and said in that International Exhibition Conference would be translated into the journals of other countries, and they ought not to let any wrong impression go forth. Mr. Cheshire had mentioned the name of Mr. Sproule as having communicated to him the properties of phenol, but if they consulted one of the numbers of the *British Bee Journal* in the year 1876, they would find there the means adopted by Italian bee-keepers for

the cure of foul brood. The Italian apiarians were in the habit of curing this disease by the use of three different kinds of acids—salicylic acid, hypermanganic acid, and phenic or carbolic acid. This was the means adopted by two distinguished apiarians, Signor Grassi and Dr. Dubini; and in a meeting of that kind it was desirable to mention the previous use of phenic acid for this purpose by others, to whom it was but just to ascribe whatever honour was due to them.

The Chairman observed that the Italians might say that, but they had apparently not applied the remedy. However, in order that the meeting might not separate quite as ignorant on this particular matter as when they came into the room, he would ask Mr. Hehner to point out to them exactly the difference between salicylic and phenol, and those other remedies which had been suggested; that was to say, where they agreed and where they differed, in as simple and untechnical a form as possible.

Mr. Otto Hehner was very loth to deliver a chemical lecture, but he would simply say that all the substances mentioned—phenol, salicine, cresol, camphor, and eucalyptol—were all parts of the same big family. They were, in fact, very closely related to each other. All volatile oils in which the odours of plants depended had practically the same composition, consisting of the two elements, carbon and hydrogen, and a few of them oxygen. Chemically there was no difference between them as far as the percentage of quantities was concerned, but they had different properties. Most volatile oils were chemically what were called turpentine. From those were derived the camphors. Of all camphor was the very weakest. It had the least action of all antiseptic agents. It was not likely to poison any animal, but it was certainly very little likely to do any good. Of all the substances carbolic acid was the strongest, and phenol and phenic acid were synonymous terms for the same thing, except that carbolic acid was generally taken to denote the impure article in this country, and phenol the pure substance, phenic acid being simply the expression used on the Continent for phenol. Between those two extremes, camphor on the one hand and phenol on the other, one representing the least active and the other the most active of these antiseptics, there were all possible gradations. People were anxious to have pleasant antiseptics, and they therefore liked to have thymic and eucalyptic preparations, but they were all less antiseptic than phenol. The chemical difference was very small, but they acted nearly all in this way, that when brought together with the juices contained in any animal, or in a plant, they combined with the albumen, coagulating it, so to speak. Those antiseptics which had been mentioned might be divided into two classes: part of them were volatile and were taken into the lungs through the air, and part of them, like salicylic acid, could not be disseminated through the air by any ordinary means, but must be taken in by the blood. Still it came to the same thing. If a substance was taken in by the lungs, it could only be taken in by small quantities at a time, and when it was taken in by the stomach it might be in larger quantities, but it was the same thing; it was brought into the blood and into contact with the albuminous substance, which would be coagulated by it and the cell killed. Permanganic acid acted in a different way; that simply gave the oxygen it contained to whatever substance it met, whether it be animal or vegetable, dead or alive; whatever it was it oxidised and destroyed it, and it was, therefore, a very injudicious substance to use, because it made no discrimination at all. Mr. Cheshire had therefore, he thought, picked out the most powerful antiseptic which could be used; it was the most useful and the most likely to have the desired effect. Of course, an infinity of others might be used which all acted in the same direction upon contagion of all varieties; but phenol

was the embodiment of what an antiseptic substance ought to be.

Mr. Mills said he had supplied Mr. Cheshire with a hive, and after listening to what had been stated at the meeting, it occurred to him that the record of that hive might answer some of the queries which had probably occurred to the minds of gentlemen present. His record of the hive went back to 1882, and since that time it had not had any addition of driven bees, nor had it had a queen introduced, and it had been a very prosperous hive through the whole of that period until the 2nd June last. Its first evidence of slackening power was noticed when dividing a swarm from it. He made a swarm which did not seem to do well, and the frames were returned to the hive, and his opinion was that this foul brood was very manifest on the 10th June, when the queen was pinched. On the 21st it was taken to Mr. Cheshire. Ligurian queen-cells had been inserted, but proved not to contain anything but the putrid remains of a queen grub.

Mr. Cheshire asked for the indulgence of the meeting if he should be somewhat disconnected in his replies, because of necessity the criticisms had gone all over the ground, and he must endeavour to run after them and catch them up as best he could. The part of the paper which unfolded the nature of the disease and exposed the numerous errors that had obtained with regard to it, and which perhaps might bear the largest amount of fruit hereafter, had hardly been noticed at all; but no one could form any notion of the enormous amount of labour which he had had in elucidating that problem, which had altogether baffled bee-keepers up to the time he undertook it. However, taking the question of the treatment of the disease—with regard to the gum of the eucalyptus tree, the blue gum, Mr. Hehner had already answered the question so admirably that there would be no necessity for him to reply to it. In arguing with reference to the cure of foul brood there were two points which required careful consideration. First of all, the actual existence of the disease should be indubitably verified. How was it known that the instances referred to, which seemed to cure themselves, were really foul brood? There were appearances like foul brood which were not foul brood at all. He might mention the case of a well-educated bee-keeper sending him a specimen of what he called foul brood from Ireland, saying that he was very anxious about it, finding his hives to be suffering badly from that disease. Well, he examined it, and found not the slightest indication of foul brood. He would say that nineteen persons out of twenty of the knowing ones would have looked at the comb sent and have said it was undoubtedly foul brood, and yet it contained no trace of it. It was nothing but putrid and chilled brood, but the difference to the unaided eye was so small between that and foul brood that they could not distinguish it unless they saw it under the microscope. He had specimens of both substances mounted as microscopic objects, and it would be seen that thus examined the two could no more be mistaken for each other than a leaf of bread could be mistaken for a leg of mutton. Those gentlemen who had spoken might be right or wrong in their ideas about what it was that was troubling them, but unless they sent the specimens to himself or some person who was capable of deciding the point, and distinguishing whether they were cases of foul brood or not, he would not like to say anything about them at all, as all debate would be but wasted time, the premises being uncertain. Then it was said that the disease was sometimes cured naturally. There was the *Spiraea ulmaria*, or the common meadow-sweet, from which the bees gathered honey, and thereby carried salicylic acid—which is naturally secreted by this plant—home to the hive in the best possible form in which it could be got; so that they had the remedy given to them by nature in the blooms of the flowers from which they gathered. As to why in diseased

hives queen-cells were so often raised, he could hardly as yet give an answer which could be considered as more than very probably correct, as at present it must rest upon theoretical grounds rather than actual observation. It was not possible for him as a single individual to gather all the material which was essential, but he took it that the explanation was this: the queen had the disease, and the bees being aware of it, attempted to displace her by raising a new one, and their queen-cells were almost always found to be abortive. Some important bee-keepers present were ladies, and he asked them and the gentlemen who kept bees kindly to assist him in this direction by sending him from hives behaving in the manner under consideration such queens as they could spare, and he would then probably have the opportunity of spotting a queen which had the disease. He had spotted drones and workers which had it, and he had not the slightest doubt in the world that the queens might have it too. From induction it seemed certain that it was so.

Then in all germ diseases there were cycles of greater or less activity, and there might be an attack of the disease in its less active spore condition, and possibly then it might, other things being favourable, disappear without assistance, but he very gravely doubted it. He had mounted some of the foul-brood matter and some of the bacilli, and the meeting would see that there were very robust specimens from a southern county. Mr. Martin had told them that he had lost 300, by his bees, and no doubt they would all heartily sympathise with him; but he knew of one bee-keeper who had lost this spring more than 2000, in bees alone. That was certainly a very considerable trial, and he had known of other cases like it. Then he had been asked whether salicylic acid was a failure as a remedy for this disease, and to that he would answer, No. It had been part of his work to assert, on more than one occasion, that salicylic acid was a cure, and he had stood almost alone, shoulder to shoulder with Mr. Cowan, defending the position of salicylic acid years ago. But what he said was that directly they associated salicylic acid with borax, they reduced its curative agency. He was certain of that, and directly they put into the hands of uneducated persons a remedy which they were to use as a spray, they did mischief, because such persons went on spraying and spraying until they killed everything. The continued mortality amongst the grubs was supposed to be evidence that the disease was still active, while in fact the larvae were dying of the doctor. His microscopic discoveries had for the first time made it possible to lay bare this fallacy. As Mr. Hehner had put before them, he did not think salicylic acid was to be compared with phenol. He had cured lots of stocks with salicylic in the past, but he would no more think of doing so now than he would attempt to swim across the Channel instead of taking a steamer. Such an easy way of curing foul brood as this being announced, surely everybody ought to take it up. Then with regard to the question of skeps, there they were on tender ground. He was not a *skeapist*, and he was very glad of it, for if he had been he would not have seen so much of bees as he had done; but in spite of the strong feeling on the part of some persons in favour of skeps, a skep was not, after all, a hive in half the senses that word ought to be used in these days, and it was in those skeps that the disease lurked. While the cottagers were in their present state of feeling with regard to skeps, the Association must be content to suggest the use of phenol. Salicylic acid was difficult to use, and they had to go through a good many processes before using it; but they could, on the other hand, take a definite quantity of phenol, put it into a measure of water and add the required quantity of the solution to each pint or quart of syrup, and make a pint of syrup, and there was the whole thing in a nut-shell. Ignorance, of course, ought to be

discouraged, but if those Italian gentlemen who had been mentioned had found a remedy so long ago, how was it that they were still suffering so much from the disease? and how was it we had suffered so much from it? He thought, therefore, if they had suggested phenol, they had never suggested the way of applying it, nor the proper proportion of it. That was probably the reason that so little had been heard about it, and he claimed for himself the discovery of the way of applying the remedy and its amount. If the remedy was applied in his way, foul brood would give them no more trouble. He might illustrate his meaning by saying that if he were a bee-keeper, depending for his living upon selling his honey and bees, and possessing say 100 stocks, it would actually pay him to allow for the sum of 2s. per stock a frame of comb in the very worst condition from disease to be put into each. Treatment would quickly make all sound and every colony would be considerably strengthened by the process. They had the very important evidence of Mr. Raynor with regard to his using a small quantity of phenol, and his possible immunity from disease in consequence of that. Well, that was very likely. He was not going to run down Italian queens; on the contrary, he had a great belief in them; but he had a greater belief in Italian queens that were raised at home, and he could say that they were far finer queens than they could ever get by importation. He had never said that those queens had introduced the disease, but he felt all but positive upon the point; and he was very sure that those who said that they had been the means of introducing foul brood into their apiaries had spoken in good faith, and had scientific evidence behind them which said that they must be right. He would like them all to go away resolved to turn over a new leaf, and not to advise every poor man to burn his combs and hives and get rid of them. That was simply saying to a poor man that he must look ruin in the face at once. They had a remedy, he would state fearlessly, which, if put into that man's hands, with a little kindly help from his perhaps better educated neighbour, would rid him of the disease without touching a bit of comb, and without unqueening a stock. If they did that they would do that man an enormous service, and help apiculture in this country. He hoped, therefore, they would all go away from the Conference with the resolution not to countenance the abominable system of wholesale destruction any longer in any case which came under their notice, or in any periodical in this country. To that end he had laboured. He had destroyed numbers of his own bees in experiment that the truth might be learned, but he should not regret them in the least if they had accomplished the object for which they had been sacrificed. There were bee-keepers now who had the disease raging in the most terrible manner in their apiaries, and if they allowed it to go on it would be shameful; and they would be the means of making their poorer neighbours suffer much more than they had ever suffered before. In conclusion, he thanked the meeting for the patient hearing they had afforded him, and hoped that some good result would come out of the discussion, so that very many bees might be saved, and very many bee-keepers as well.

The Chairman proposed a hearty vote of thanks to Mr. Cheshire for his able paper, and for the remarks he had made in answer to the observations addressed from the meeting. That the subject was a most important one they could easily imagine when they heard of one man losing 2000, though, perhaps, he might be better able to afford the loss than the poor cottager who had lost 300, by his bees. It was a miracle that any bees should have escaped at all after what they had heard. It seemed that the queen might give it to the bees, or they might get it from the flowers, where it had been left by the legs and antennae of the bees who had been there before. There was one comfort, at all events, and that was that nature furnished the bees with a

remedy in *Spirea ulmaria*, which supplied them with salicylic acid in its best form for their use. They could hardly, perhaps, appreciate the labour by which Mr. Cheshire had arrived at the results he had reached; but undoubtedly Mr. Cheshire had marked out a new path in the history of apiculture. He had not heard anything before that day of this *bacillus alvei*, to which he was to be godfather; it seemed, however, that it would be his duty not to bring it up carefully, but to hunt it out and destroy it. If this *bacillus alvei* were the cause of this disease, as *bacillus* were the cause of cholera in human beings, and of glanders in horses, they would see how terrible an enemy it was. Mr. Cheshire had opened out a wide field of research, and he thought that a good many people besides bee-keepers would do well to profit by his labours. However, they had only to deal with the *bacillus alvei* at present, and their thanks were due to Mr. Cheshire for having directed their attention to this noxious pest, and for pointing out the remedy they should employ against it. It seemed to be the general consensus of opinion in the meeting that phenol was the best remedy to employ, and more likely to be efficacious than any other remedy. He hoped they would meet together to-morrow to discuss the subject of adulteration of honey, and how it might be counteracted, and that they would then and subsequently hear the results of the experience of gentlemen who had tried that remedy.

The Rev. V. H. Moyle, as a bee-keeper, who had had considerable experience of foul brood, had great pleasure in seconding the resolution, and also in thanking Mr. Helmer for his very instructive remarks.

Mr. Cheshire, in returning thanks, earnestly invited the members present to communicate with him on the subject, and to afford him any information in their power.

[The preceding discussion has occupied so much of our space that we are reluctantly obliged to defer the discussion on Mr. Helmer's paper to our next number.]

## ASSOCIATIONS.

### BRITISH BEE-KEEPERS' ASSOCIATION.

Committee meeting held at 105 Jermyn Street on Wednesday, August 20th. Present: Rev. H. R. Peel in the chair, the Rev. F. S. Selator, Hon. and Rev. H. Bligh, Rev. F. G. Jenyns, J. M. Hooker, D. Stewart, and the Secretary. The minutes of the last committee meeting were read, confirmed, and signed. The County Associations Sub-Committee reported that Associations had been successfully inaugurated in the counties of Flintshire, Denbighshire, and Carnarvonshire, the Lord Lieutenant of each county having consented to act as President. Steps were also being taken towards the formation of an Association for Angleson. A letter was read from the Rev. J. Lingon-Sager, Hon. Secretary of the Hertfordshire Association, calling attention to the advisability of some general rules being made for the guidance of judges in giving their awards for both comb and extracted honey. The next Committee Meeting was fixed for September 24.

### DORSETSHIRE BEE-KEEPERS' ASSOCIATION.

This Association held its second annual meeting in connexion with the Yeovil Floricultural and Horticultural Society on Tuesday, August 19. The exhibition was held in the grounds of Brighthelm, Henford, kindly lent by Mrs. Greenham. Three tents were set apart for the accommodation of the Association. The principal tent ran to 100 feet in length, and was filled from end to end with four rows of staging, the staging being occupied with fine displays of hives and other apicultural apparatus contributed by the leading manufacturers in the Kingdom. Among the various firms represented were Messrs. Abbott Bros. of Southall, Mid-

d Essex; Messrs. Dines and Son, Maldon, Essex; Messrs. Hart and Co., Longstock, Hants; and Messrs. Richards and Honey, Exeter. All these exhibitors sent samples of their best work, and their exhibits attracted much attention. A very pleasing and interesting feature of the exhibition was the large number of local exhibitors who put in an appearance, amongst whom Mr. G. Evans, of Hechester, and Mr. C. E. Pyne and Mr. A. White, of Yeovil, deserve special note. In the honey class the exhibits were agreed by judges to be superior both in quality and in quantity to any ever before seen in the West of England. One exhibitor, Mr. W. H. Dunman, jun., of Troytown, Dorchester, the energetic and devoted hon. secretary of the Association, sent about five cwt. of splendid sections, and carried off a number of prizes. Mr. Antell, of Puddletown, was also a successful exhibitor, as likewise were the Rev. N. W. Gresley, of Milborne St. Andrew; Mr. G. D. Murray, Yeovil; and Mr. G. E. Dyke, Milborne Port. The silver medal offered for the best 24-lb. sections, which has on so many occasions gone to the hon. secretary, was now taken by Mr. S. Pond, of Blandford, whose success was regarded with much good-natured satisfaction by reason of its breaking down the supremacy in this department hitherto held by Mr. Dunman. Mr. W. Pavitt, of Barwick, near Yeovil, was awarded the bronze medal for his exhibit, which appeared thoroughly to deserve the distinction. The attractiveness of the show was much increased by the manipulations which were conducted during the afternoon in the operating tent by Mr. S. J. Baldwin, of Bromley, Kent. Mr. Baldwin, who is the expert-in-chief of the British Bee-keepers' Association, explained the manipulations as they proceeded, and the tent was crowded to excess on every occasion by people who apparently took the greatest possible interest in the operations.

Mr. J. A. Abbott exhibited a case containing specimens of comb and queen-cells in various stages of formation, comb-foundation, &c., forming quite a little bee-keepers' museum. The Rev. C. G. Anderson exhibited an Alphabet of Apiculture, admirably illustrated with pen-and-ink sketches of his own design, which deserves a greater permanence than it could possibly have at a provincial show. The Rev. V. H. Moyle had also sent a box containing Messrs. Huntley and Palmer's honey drops, honey drinks, honey wine, honey medicines, &c.

By the kindness of Mr. C. Tite, who is himself a well-known bee-fancier, and who worked very cordially with the other officers of the Association to make the day so entirely successful, the apiculturists attending the exhibition were invited to partake of a luncheon. The Chair was occupied by Mr. Tite, who was supported by the Mayor of Yeovil; the Rev. C. G. Anderson, Otterhampton, hon. sec. to the Somersetshire Association; Rev. W. E. Burkitt, hon. sec. of the Wiltshire Association; Mr. Kent, hon. sec. of the Cornwall Association; Mr. Griffin, hon. sec. of the Devonshire Association; Mr. Henderson; Rev. L. Stanton, Combe Keynes; Dr. McLean, Portland; Mr. J. F. Hassay, Dorchester; Mr. Best, Dewlish; Mr. J. Abbott, Mr. Hart, Mr. W. R. Vatcher, Dorchester; Mr. J. Brown, Maiden Newton, and many others, who were either connected with the Association or interested in bee-keeping. An excellent repast was served by Mr. Leach, and upon its conclusion a brief toast-list was gone through. The Chairman first proposed 'Success to the Dorsetshire Bee-keepers' Association,' with which he coupled the name of Mr. W. H. Dunman, the hon. sec., whose ind-fatigable courage, energy, and zeal he highly eulogised. He (the Chairman) thought the Association had shown that day they thoroughly deserved success, and they would all hope the present meeting would be the means of putting fresh zeal into Somersetshire people, so that next year if they did not have a show in Yeovil they would at least have one somewhere in the county that would soon become a rival of the Dorset Association. Mr. Dunman, in responding, spoke of the very great

interest he had taken in the work of the Association since its formation, particularly for the sake of poor people, and he was very delighted at the number of entries received for the cottagers' classes at this show. He was also very pleased to say the cottagers were becoming members of the Association in good numbers. With regard to the exhibition generally, his ambition was to see the Dorsetshire Association stand next to the British Bee-keepers' Association, which he looked upon as their parent; and if he had succeeded in raising their Society to this position he was very glad, while if he had not yet succeeded he hoped to do so another time.

The following is the prize list:—

HIVES, HONEY, &c.—Observatory Hive—1st, 1l., Messrs. E. M. Hart and Co., Longstock, Stockbridge; 2nd, 10s., Mr. W. H. Dunman, Troytown. Collection of hives and bee-furniture—1st, 1l. 10s., Mr. S. J. Baldwin, Bromley; 2nd, 1l., Messrs. Abbott Bros., Southall, and Messrs. Richards and Honey, Exeter (equal). Moveable comb hive—1st, 1l., Mr. S. J. Baldwin; 2nd, 10s., Messrs. Abbott Bros. Ditto for cottagers' use—1st, 10s., Messrs. Dines and Son, Maldon; 2nd, 5s., Mr. S. J. Baldwin; h. c., Mr. J. Blake, Ipswich. Section rack—1st, 10s., Messrs. Richards and Honey; c., Messrs. E. M. Hart and Co. Crate for conveyance of honey—1st, 5s., Mr. S. J. Baldwin; c., Messrs. Richards and Honey. Honey extractor—1st, 10s., Messrs. Abbott Bros.; 2nd, 5s., Mr. A. White, Yeovil. Slop and sectional super—1st, 10s., Mr. C. W. Downes, Blandford; 2nd, 5s., Messrs. Abbott Bros. Thick comb foundation—1st, 5s., Mr. C. W. Downes; c., Messrs. Abbott Bros. Thin ditto—1st, 5s., Messrs. Abbott Bros. Feeder—1st, 5s., Messrs. Dines and Son. Honey (for exhibitors residing in Dorset or within six miles of its confines)—Exhibit of super honey—1st, 1l., Mr. J. Antell, Puddletown; 2nd, 10s., Mr. W. H. Dunman; 3rd, 5s., Rev. N. W. Gresley, Milborne St. Andrew. Super—1st, 10s., Mr. W. H. Dunman; 2nd, 5s., Mr. S. Smith, Charlton Horethorne; 3rd, 2s. 6d., Mr. W. Dikken, Remptone. Twenty-four 1-lb. sections—1st, silver medal, Mr. S. Pond, Blandford; 2nd, 7s. 6d., Mr. W. H. Dunman; 3rd, 5s., Rev. N. W. Gresley. Twenty-four 2-lb. sections—1st, 10s., and 3rd, 5s., Mr. W. H. Dunman. Twelve 1-lb. sections—1st, 7s. 6d., Mr. G. E. Dyke, Milborne Port; 2nd, 5s., Mr. E. C. Lander, Sherborne. Twelve 2-lb. sections—1st, 7s. 6d., Mr. W. H. Dunman. Forty-eight lbs. extracted honey—1st, 10s., Mr. J. Antell; 3rd, 5s., Mr. W. H. Dunman. Twenty-four ditto—1st, 10s., Mr. G. D. Murray, Yeovil; 2nd, 5s., Mr. Marriott, Moreton. Special prizes (given by Mr. C. Tite).—Exhibit of super honey from Devon, Wilts, or Hants—1st, 1l. 1s., Messrs. Richards and Honey. Super honey from an apiary in Somerset—2nd, 7s. 6d., Mr. H. Dumean Skrine, Claverton, Bath. Exhibit of honey in 1-lb. or 2-lb. jars from an apiary in Somerset—1st, 10s. 6d., Rev. C. G. Anderson, Otterhampton, Bridgwater; 2nd, 7s. 6d., Mr. T. Hallett, Otterhampton.

COTTAGERS' CLASSES.—Super—1st, 10s., W. Dikken; 2nd, 5s., W. A. Pavitt, Barwick. Honey in comb—1st, 10s., W. Dikken, Remptone; 2nd, 5s., W. A. Pavitt. Twelve 1-lb. sections—1st, bronze medal and 10s., W. A. Pavitt; 2nd, 5s., S. Feaver, Sherborne. Twenty-four lbs. run honey—1st, 10s., W. Dikken; 2nd, 5s., W. A. Pavitt. Straw skep of bees—1st, bar-framed hive, Mr. G. Chaffin, Yeovil.

In the neighbourhood of Yeovil several flower-shows, with which have been combined bee and honey shows, have been held; among others Hatch Beauchamp, Somerton, Street, North Perrott, and Stoke-sub-Hamdon.

A Conference of County Secretaries was held in the committee tent during the afternoon, Somerset, Dorset, Wilts, Devon, and Cornwall being represented by their respective secretaries, namely, Rev. C. G. Anderson, Otterhampton, Bridgwater; Mr. W. H. Dunman, jun., Troytown, Dorchester; Rev. W. E. Burkitt, Buttermore, Hungerford; Mr. W. N. Griffin, Exeter; and Mr. Kent, Truro. Mr. Dunman, who presided, said he exceedingly regretted the absence of the Rev. H. R. Peel, whom he had hoped to have seen with them that day, but who had found it impossible to attend. He (the Chairman) thought, as he had so many of his friends together, it

would be an excellent opportunity to discuss a few matters connected with bee-culture. In the first place, he wanted to point out that counties far away from London were not fairly represented at the Conferences of the Central Association. He suggested that the western shires should come to an arrangement that at least one of their representatives should go to each quarterly meeting, and be empowered to vote for all the Associations that formed the federation. The expenses could be shared, and the burden would thus be lightened, while direct representation would be ensured. He feared there was some doubt at present whether counties were entitled to one vote or two, as some sent only one representative and others sent two. It would be as well to have this cleared up, so that no county should have more than its fair voice in the affairs of the Central Association. Mr. Griffin, Rev. C. G. Anderson, and Mr. Kent, promised to bring the suggested amalgamation before their respective committees. The Rev. W. E. Burkitt said he had found no difficulty in attending the London meetings, and did not therefore care to join. Mr. Griffin thought it was never intended for any county to have more than one vote. The reason two representatives were appointed was to make sure that the county should have one to send. He then referred to the difficulty experienced in disposing of honey. The Reading depot was full, and he had tried in vain to open up a connexion with London houses. He had an interview with the manager at Messrs. Fortnum and Mason's, who strongly advised him to try to sell in his own county even at 1d. or 2d. below London prices, so as to save risk and cost of carriage. He felt, therefore, that they must endeavour to open local depots, until the British Bee-keepers' Association could see their way to open a central depot. He had tried the grocers at Exeter and Torquay, but so far he had not been very successful, as they preferred buying the American honey, because it was so much cheaper. He had been thinking this matter seriously over lately, and he felt that they ought to call public attention generally, and the attention of county analysts in particular, to the impurities of the so-called American honey. If this were done, there would be something like a fair field open for the pure British honey. Mr. Henderson, who had been invited to attend the meeting, reminded those present that this course had been adopted in Glasgow some years ago with the most beneficial results. The Rev. C. G. Anderson said he had taken samples of honey to grocers at Weston-super-Mare and Clevedon, and hoped a sale might eventually be got up; but foreign honey was in favour with tradesmen at present, because of the low price at which it could be procured. Mr. Dummer remarked that he took a crate of sections and some sample bottles and run-honey to some of the leading grocers in Weymouth recently and obtained some orders. Mr. Kent said the bee-keepers in Cornwall were most anxious to secure a market for their honey, as the local grocers and chemists bought foreign stuff. A general hope was expressed that the Central Association might some day see their way to help the counties in this matter, and that in the meantime the subject should be thoroughly discussed. Mr. Dummer then asked for information as to the most marketable form of honey. He found large supers growing in favour with dealers. Mr. Griffin said his experience had been the same; and he was sending a number of large supers to London to fulfil a special order. A special vote of thanks was passed to Mr. Henderson for attending the meeting on the motion of Mr. Griffin, seconded by Mr. Kent.

#### WILTS BEE-KEEPERS' ASSOCIATION.

The County Show was held in connexion with the Keevil District Horticultural Society's Fête in Dighton Park, Westbury, on August 13. The entries were more numerous, and the show of honey far larger, than on any

previous occasion. The cottagers, unfortunately, are still very backward in exhibiting, though many in the county might have done so with credit. There was, as might be expected, a keen competition for the silver and bronze medals given by the B. B. K. A.

During the day an examination was held of candidates for the third-class experts' certificates given by the B. B. K. A., by whom also the examiner and one of the judges were appointed. Six candidates had entered their names, but harvest work and other causes reduced the number who put in appearance to four. Owing to the short time available for displays in the bee tent, all the driving, &c., was performed by the candidates in the presence of the British Bee-keepers' examiner, W. N. Griffin, Esq., Hon. Secretary of the Devon and Exeter B. B. K. A., explanations and advice being given to the visitors by the experts of the Association and other members of the committee. Mr. John Rogers, of the Iron Works, Westbury, a most zealous bee-keeper, kindly provided bees for driving, and another stock in bar-frame hive for the use of candidates in their examinations.

The following prizes were awarded by the judges, W. N. Griffin, Hon. Secretary of the Devon and Exeter B. B. K. A., and W. H. Dummer, Esq., jun., Hon. Secretary of the Dorset B. B. K. A.:

Bees, &c.—Class 1.—For the best stock of bees of any race, to be exhibited with their queen in an observatory hive. 1st prize, 10s.; 2nd prize, 7s. 6d. 1st, E. M. Hart, Longstock; 2nd, no entry. Class 2.—For the best observatory hive stocked with bees and their queen. 1st prize, 10s.; 2nd prize, 7s. 6d. 1st, H. W. Taylor, The Island, Melksham; 2nd, Rev. W. E. Burkitt, Buttermere. Class 3.—For the best bar-frame hive, complete, price not to exceed 15s. 1st prize, 7s. 6d.; 2nd prize, 5s. 1st, J. E. Wiltshire, Semington; 2nd, R. Webb, Westbury. Class 4.—For best bar-frame hive for cottager's use, price not to exceed 7s. 1st prize, 5s.; 2nd prize, 2s. 6d. 1st, J. E. Wiltshire, Semington; 2nd, C. E. Pyno, Yeovil. Class 5.—For the best collection of bee furniture. 1st prize, 15s.; 2nd prize, 10s. Rev. W. E. Burkitt and E. M. Hart, *opud* firsts. Class 6.—For the best arrangement for obtaining super honey from skeps, price to be considered. Certificates of Merit. 1st, Rev. W. E. Burkitt; 2nd, E. M. Hart. Class 7.—For new inventions of general use in the apary. No awards.

Honey.—Class 8.—For the best exhibition of super honey from an apary. 1st prize, 10s.; 2nd prize, 7s. 6d. 1st, Rev. W. E. Burkitt; no other entry. Class 9.—For the best 24 lbs. of honey, 1 lb. or 2 lb. sections, and 12 lb. extracted honey. 1st prize, silver medal of B. B. K. A.; 2nd prize, bronze ditto. 1st, A. G. Kadeffe, Esq., Fonthill; 2nd, Rev. W. E. Burkitt. Class 10.—For the best super of honey (not being sectional). 1st prize, Certificate of B. B. K. A. H. W. Taylor, Melksham. Class 11.—For the best 12 lbs. of extracted honey in 1 lb. or 2 lb. glass jars. 1st prize, 5s.; 2nd prize, 2s. 6d. 1st, Mr. A. W. Hall, Bruton; 2nd, Mr. G. Child, Semington; highly commended, Rev. W. E. Burkitt. Class 12.—For the best old stock of bees in straw skep. 1st prize, a bar-frame hive worth 7s. 6d.; 2nd, a Buttermere skep crate. 1st, Rev. E. Davenport; 2nd, Mr. John Rogers, Westbury. Class 13.—For the best bees-wax, not less than 5 lbs. 1st prize, 5s.; 2nd prize, 2s. 6d. 1st, E. Day, Mildred Hill, Salisbury; 2nd, S. W. Gaily, Semington. Class 14.—For the competitor who shall in the neatest, quickest, and most complete manner drive out the bees from a skep and exhibit the queen. Certificates of Merit. 1st, C. Warden, head gardener at Clarendon Park; 2nd, W. S. Bambridge, Esq., Mus. Bac., Marlborough College; 3rd, Thos. Clew, Melksham.

COTTAGES.—Class 15.—For best sectional super of honey (special prize offered by T. Herbert Clark, Esq., Wingfield). 1st prize, 5s.; 2nd prize, 2s. 6d. 1st, Thos. Clew, Melksham; 2nd, H. Bartley, Colford, St. Peter's. Class 16.—For the best super of honey, not sectional. 1st prize, 5s.; 2nd prize, 2s. 6d. 1st, T. Clew, Melksham; 2nd, Isaac Hoare, Fosbury. Class 17.—No entry. Class 18.—For the best flat-topped Skep, with feed-hole, super, and floor-board. 1st prize, 5s.; 2nd prize, 2s. 6d. 1st, H. Huish, Patney, Devizes; 2nd, G. White Bagshot, Hungerford.

On the following day, August 14th, the Hon. Secretary took the bee tent, and most of his exhibits at Westbury, to a Cottage Garden Show at Wootton Bassett, all the arrangements for this bee show being satisfactorily carried out by H. Bevir, Esq., one of the District Secretaries of the Wilts B. K. A., who also gave most efficient assistance in the manipulations. Both those Shows were well attended. Cottagers seemed most anxious to learn all they could, and many of this class might have been successful candidates for the expert examinations had they not been too diffident. Encouraged by the fineness of the season, a number of new members have joined the Association during the summer.—W. E. BERRITT, *Hon. Secretary.*

N.B.—The names of the successful competitors for third-class experts' certificates will be given in the *British Bee Journal* for September 15th.

#### LEICESTERSHIRE BEE-KEEPERS' ASSOCIATION.

This Association held its second show of the season at Melton Mowbray in connexion with the Melton Mowbray Horticultural Society, which generously contributed half the prizes offered. Through the instrumentality of J. W. Bickley, Esq., the Volant or Tent was secured for the occasion, and, though small, answered its purpose admirably. There was an excellent display of honey, in jars, sections, and supers. Mr. Bickley's magnificent display of super-honey excited universal admiration, and it must be confessed that it is seldom the lot of bee-keepers to be able to stage such an enormous weight of honey from one apiary. Mr. Ball's glass super (now on exhibition at the 'Hoarderies'), with comb  $4\frac{1}{2}$  inches thick, also attracted some little attention.

There were some good collections of bee appliances, those of Mr. C. Radshaw, of Leicester, and Mr. W. P. Meadows, of Syston, being very large and full. The hives—for convenience, placed outside the tent—underwent a severe scrutiny by members of the bee-keeping fraternity. The bee-tent did not arrive in time for the show; a temporary inclosure was, therefore, run up, and, by aid of the Association's screen, a tolerable substitute was obtained. Only one exhibition of bee-driving took place, as, from the great weight of the stock, the great heat, and other causes, a second could not safely be attempted. Mr. W. S. Pridmore, who was engaged as expert and lecturer, succeeded in imparting some useful and interesting information on bee-keeping to attentive and numerous audiences. It may interest some of those who were present to know that, though all the combs had to be removed from the hive, the stock, aided by one of Mr. W. P. Meadows's Raynor Feeders, is in a fair way of recovery. The bees are carrying in pollen abundantly, and defending themselves valiantly against robbers, wasps, and other unwelcome intruders. It is much to be regretted that no entries for the Special Prizes for Cottagers were made.

#### YARMOUTH FLOWER SHOW.

The Great Yarmouth, East Norfolk and Suffolk Horticultural Society held their annual *fête* in St. George's Park on Thursday, August 7th, under the most favourable circumstances. The weather—so important a factor in matters of this kind—was gloriously fine, and the show on the whole may be said to have been a decided success. As customary, in addition to the show proper, a bee-tent, supplied by the Norfolk Bee-keepers' Association, was erected, and the public being admitted free, a large number diverted their attention to this department. Here were to be observed the Rev. L. Sisson, assisted by Mr. T. C. Edmonds and Mr. Chaney, whose movements among the buzzing tribe were keenly watched by the

on-lookers. Mr. T. C. Edmonds having given a lucid explanation of the bar-frame hive, the Rev. Mr. Sisson proceeded to make a few observations on the progress of bee-keeping.

The following is the list of awards:—

**BEEs.**—Best stock of Ligurian or other foreign bees.—1. S. Barge; no second or third. Best stock of English bees.—1. S. Barge; no second or third.

**HONEY.**—Best super honey, from one apiary.—1. H. Bartram, Hasbro'; no second or third. Best super of honey, the same super to be of wood, glass, straw, or of wood in combination with straw or glass.—1. J. Lawrence, New Buckenham. 2. W. Carbound, Yarmouth. Best twelve 2-lb. sections in comb.—1. A. C. Stead, Necton; no second. Best twenty-four 1-lb. sections in comb.—No first. 2. W. Carbound. Best twelve 2-lb. jars extracted honey.—1. A. C. Stead. 2. D. P. Meadows, Yarmouth. Best twelve 1-lb. jars extracted honey.—1. A. C. Stead. 2. S. Barge. Largest and best collection of extracted honey in glass jars.—1. A. C. Stead. 2. D. P. Meadows. Largest and best exhibition of honey in comb, taken from one hive without destroying bees.—1 and 2. H. Bartram.

#### BRECKNOCKSHIRE BEE-KEEPERS' ASSOCIATION.

This Association held its first show of honey this year in connexion with the Brecon Flower Show, held on 20th August. About 500 lbs. of honey were staged, nearly all of which were excellently prepared for exhibition. The extracted honey showed a marvellous improvement on last year, being clean and nicely arranged in neat glass-bottles. The sections, too, were very numerous; one-pound sections seemed to be the favourite, although there were several excellent specimens of two-pound sections as well. The judge was Mr. Hole of Ledbury. We are very pleased to find our excellent Secretary carried off one of the first prizes, *i. e.*, for sections; indeed, the village over which she immediately presides carried off three first prizes.

Another exhibition of honey, wax, and bee-furniture, will be held at Brecon on Wednesday, the 10th of September, in connexion with the Agricultural Society, when it is expected that an even larger amount of honey, &c., will be staged.

Below we append the prize list:—

For the best 12 lbs. of honey in combs.—1. Miss Swinton, Llanfihangel-tal-yllwn. 2. Rev. Rees Price, Llanfaen. 3. Mr. Kettle, Workhouse, Brecon. For the best 12 lbs. of extracted honey.—1. Mrs. Cleary, Penycyre. 2. Mr. G. Garrons Williams, Abercamlais, and Mr. Kettle, Workhouse. 3. Mrs. Rees Price, Llanfaen.

**COTTAGERS' CLASSES.**—For best honey in combs.—1. Mrs. Morgan, Llanfihangel-tal-yllwn. 2. Mrs. Larkin, Llanfrynach. 3. Mrs. Williams, Llanillo. For best honey extracted.—1. Mr. E. Richards, Llanfihangel-tal-yllwn. 2. Mrs. Jarmyn, Velinfach. 3. Mrs. Williams, Llanillo.

#### BEE-KEEPING IN NORTH WALES.

(From the *Itinerary of a Secretary.*)

*July 31st.*—I attended with our bee tent at the Carmarthen Horticultural Show, and was assisted by the Rev. H. Evans, Pembrey, and Mr. W. Spurrell.

*August 4th.*—At Llanelli Flower Show, assisted by the Revs. H. Evans and W. Jones, Llannon.

*6th.*—Attended the Monkton and South Pembrokeshire Horticultural Show, held in Pembroke Castle, as judge of the honey department. The exhibits in the honey classes were very good. Mr. R. R. Caver, Wwallth, showed some very perfect 1-lb. sections and some excellent run honey in 1-lb. bottles; also a stock of bees in an observatory hive. The prize for a bar-frame hive, the work of an amateur, was awarded to Mr. Harris, The

Bank, Pembroke. In the course of the afternoon I drove three stocks of bees in the presence of a fairly large number of interested spectators. Dr. Wall, of Pembroke, assisted. He has promised to assist in the establishment of the Pembroke-shire Association. Very great interest is taken in the subject in this neighbourhood.

8th.—Portmahé Horticultural Society, Carnarvon-shire. This Show was a large one and well attended. Our tent, which was despatched from Llanfily on the 4th, did not arrive in time; I had therefore to drive in the open air. Mr. W. A. Dew, Hon. Secretary of the Carnarvonshire B. K. A., assisted. The absence of the tent was by no means a drawback. I think when no charge is made it can very well be dispensed with, as it has much more moral effect upon the spectators to have shared the imaginary dangers of the manipulators. I drove four times, and on each occasion the number of spectators was too large for the tent. The last time I had to get four policemen to keep the crowd back.

9th.—Drove two stocks at Tanybwch, near Maentwrog, in Merionethshire, in the presence of a small number of spectators.

11th.—Drove twice at Llanrwst, in Denbighshire (Fair-day) in the lawn of the 'English Hotel.'

12th.—Abegobé Flower Show. Drove five times, assisted by Mr. E. W. Davies, Hon. Secretary of the Denbighshire B. K. A. Tent well filled each time. In the afternoon an informal meeting of the Denbighshire B. K. A. was held in the secretary's tent. The Rev. Evans, Vicar of Abegobé, took the chair. The speakers in favour of the movement were the Chairman, Mr. Dew, Bangor, Mr. Davies, Hon. Secretary, myself, and other. Several members were enrolled.

14th.—Hawarden Flower Show. The attendance at the Show was good, but no arrangements had been made for announcing the attendance of the bee tent and time of drivings. The tent was also stuck in an out-of-the-way place in the midst of a lot of trees. The tent was fairly well attended, but not as well as it would have been if the arrangements had been a little more complete. Among the visitors were the Rev. S. E. Gladstone, W. H. Gladstone, Esq., M.P., and other members of the family. I was assisted by the Rev. J. Evans, of Buckley, who is prepared to work up the Flintshire Association in his own district. Some good supers of honey were shown by Mr. Goo, Spencer, Miss Glyme, and others. The prize for stock in straw skep was awarded to Mr. G. Spencer.

15th.—On Friday I assisted Mr. W. H. Gladstone to remove some bees which have been in possession of the top of a bow window at Hawarden Castle for the last eighteen years. We first removed the lead and wood-work which covered the greater part of the comb. After taking out seven buckets of honey and comb, we found that the bees had worked down behind the wood-work of a window in a bedroom beneath. This had to be removed before we could effectually eject the trespassers. Some of the combs were five feet long, and perfectly full of sealed honey. Mr. Gladstone has since had the honey taken weighed; it came to 102 lbs. Besides this we must have wasted a very large quantity, as many of the combs were very awkwardly situated.

The Carnarvon and Denbigh Associations are in very good hands, and will soon be placed on a substantial footing. The Flintshire Association is also in a fair way. I had not the pleasure of meeting Mr. Keefe & Evans. Mr. Dew says he can find you a secretary for Anglesea.

One thing I forgot to mention is—At Llanrwst on the 11th I visited a local bee-keeper (a cottager) of the name of Berry. He has an apiary of about fifteen stocks, almost all bar-frames. They are kept in a very small garden, and under every disadvantage. Notwithstanding Mr. Berry has taken a very large harvest of honey, and appears to be a thorough bee-master. The Denbigh

Association need not be long without a local expert. Several of his stocks are Ligurians. The greater part of North Wales that I visited is one mass of heather, and I think the grandest bee-country I have ever been in.—L. OSWALD LEWIS.

#### BEE SHOW IN THE ISLE OF MAN.

At the Agricultural Show held at Ramsey on August 7th some prizes were offered for bees, honey, &c. The entries were few, but the exhibits were good. For the best bar-frame hive and colony of bees Mr. E. C. Kerr took the first prize, as well as that offered for the best sample of Manx honey in the comb. For the best twelve 1-lb. sections Mr. Alfred Cubbon obtained first prize with a beautiful set of sections. For the best extracted honey Mr. A. W. Moore obtained first prize. An almost complete set of modern bee-furniture was exhibited, and attracted considerable attention. Mr. G. Drinkwater was present to explain the use of the various appliances.

#### CALEDONIAN APARIAN SOCIETY.

The following are the names of the first and second prize-takers in the various departments of the Caledonian Aparian Show, a report of which appeared in our issue of August 14:—

Bees. Best stock of British bees—1, gold and silver medal, Wm. Sward, Falkirk; 2, Wm. Mann, Arbroath. Best stock of Cyprian, Ligurian, or any other foreign bees—silver medal, R. McNally, Winton; 2, Wm. Sward.

Hives. Best hive for observation purposes—1, and Highland and Agricultural Society's silver medal, Wm. Thom, Blantyre; 2, Wm. Mann. Most complete bar-frame hive on the movable comb principle, stocked with bees and their queen, showing super arrangement in full operation, or duplicate hive—1, Wm. Thomson; 2, Wm. Sward, Falkirk. Best movable comb hive—1, Wm. Thomson; 2, R. Steele, Newport. Best frame hive for general use—1, Wm. Thomson; 2, R. Steele. For inventions or improvements in hives and appliances—1, Wm. Thomson; 2, John Armstrong, South Ayr. Best straw hive of any description—1, W. and R. McNally, Glenure; 2, R. Steele. For the best hive on the stationary principle—1, R. Steele; 2, Wm. Thomson.

Com. For sections. Best sample of comb foundation—1, W. and R. McNally; 2, Wm. Bant, Blairgowrie. Best two samples of wax—1, Wm. Ridd; 2, R. Steele.

Honey. Best display of honey and honey comb—Highland and Agricultural Society's silver medal and 1 and 2, W. and R. McNally. Best two supers above 20 lbs. each—1, James Morton, Dalry; 2, James Crawford, Annan. Best super above 20 lbs.—1, William Loughland; 2, James Gormel. Best super above 10 lbs. and under 20—1, W. and R. McNally; 2, E. McNally, Inverhunger. Best super of honey not being sectioned supers; the super to be of wood, straw, or of wood in combination with glass or straw, not less than 12 lbs.—W. and R. McNally. Best twenty-four 2-lb. sections of comb honey—1, Chas. Carnegie, Montrose; 2, W. and R. McNally. Best twenty-four 1-lb. sections of comb-honey—1, W. and R. McNally; 2, Chas. Carnegie. Best twenty-four 12-lb. sections of comb honey—1, Rev. Frank Taylor, Cumberland; 2, Wm. Lowe, Standy. Best twelve 2-lb. sections of comb honey—1, Wm. Lowe; 2, Leslie Tart, Aberdeen. Best twelve 1-lb. sections of comb-honey—1, W. and R. McNally; 2, D. McIntosh, Liff, Dundee. Best run of extracted honey, in twelve 2-lb. glass jars—1, Chas. Carnegie; 2, David Macintosh, Dundee. Best exhibition of run or extracted honey in twelve 1-lb. glass jars—1, Chas. Carnegie; 2, W. and R. McNally.

SPECIAL PRIZES FOR LIONS.—Best super above 10 lbs. and under 20 lbs.—Mrs. McNally. Best glass super of honey-comb—Mrs. McNally. Best sample of run or extracted honey in glass jar containing not less than 12 lbs.—Mrs. Thomson, Dalbeattie.

COMESTIBLES.—Best liqueur or wine made from honey, with recipe attached (not less than two quarts); age of wine to be given—small silver medal, Wm. Sward, Falkirk.

Best meal or beer made from honey, with recipe attached (not less than two quarts)—Small silver medal, Wm. Sword. Best cakes made with honey, with recipe attached (not less than 2 lbs.)—Small silver medal, Wm. Sword.

MISCELLANEOUS.—Best collection of hives, bee furniture, bee gear—1, R. Steele; 2, W. W. Young, Perth. Cheapest, neatest, and best tray of supers for producing honey-comb in a salable form—1 and 2, R. Steele. Best honey extractor—1, W. W. Young; 2, R. Steele. Best and largest display of honey-producing plants—1 and 2 (silver medal), W. and R. McNally. Best collection of natural enemies of honey-bees—1 and 2 (silver medal), W. and R. McNally. Best straw hive stocked with bees, to be used at the driving competition—1, 2, and 3, James Johnston, Stirling.

#### THE STRABANE BEE AND HONEY SHOW.

This show was held on July 30 and 31, in connexion with the dog, poultry, and flower shows. All these shows were managed by Mr. W. R. Orr with that energy and skill which command success. The display of honey was large and of excellent quality, showing what can be done in a good season by careful and intelligent management. The exhibits of Mr. Humphreys, Milltown House, Strabane, and Mr. Orr, were especially worthy of note. The former won the prize for the best super of honey over 25 lbs. in weight with a splendid super of clean, well-built combs. Mr. Orr and Mr. Lonsdale showed first-class collections of hives and appliances, the latter taking a prize for an ingenious observatory hive of his own invention. This is the first reasonably good honey year that there has been in the north of Ireland since the introduction of the bar-frame hive, and the results as seen at Strabane are most encouraging. The bee-driving competition was not in keeping with the honey exhibits, only two competitors entering, and the hives for driving not being in good order. Each day was dark and showery so that a considerable time was occupied in completing the operation. It is to be hoped that the large yield of honey this year will encourage bee-owners to be their own 'manipulators.' It seems that at present there is a tendency to trust to the skill of one or two obliging persons in each district instead of each man managing his bees for himself. Bee-keeping cannot be permanently successful unless the owner has the knowledge and dexterity which can only be acquired by practical acquaintance with their management.

#### BEE-TENT ENGAGEMENTS.

ESSEX BEE-KEEPERS' ASSOCIATION.

Sept. 10.—Southminster Horticultural Society.

WARWICKSHIRE BEE-KEEPERS' ASSOCIATION.

Sept. 2, 3.—County Show, Stratford-upon-Avon.

Sept. 9.—Bedworth.

SUSSEX BEE-KEEPERS' ASSOCIATION.

Sept. 4.—Hoisham.

A WASP'S NEST IN A BEDROOM.—A farm labourer residing at Fenton-by-Stutton, near Newark, the other day, discovered a wasp's nest in a crevice underneath his bed-room window. To dislodge the wasps was the work of only a few minutes, but to his horror they flew through the open window into his bedroom. On proceeding upstairs he found that the angry insects were swarming in all directions, some were creeping among the bed-clothes, whilst others were disporting themselves on the carpets and walls. He speedily beat a retreat, and commenced a state of siege. Notwithstanding every effort to remove them, the wasps bravely held their own and kept possession of the room for two or three days, all intruders being pleased to make good their escape. Eventually the process of fumigation began to tell, and at the end of the third day the last company of the gallant invaders found it necessary to evacuate their strong position.—*Grantham Journal, August 23rd.*

## Correspondence.

\* \* \* All Correspondents forwarding Letters for insertion in the Journal, Reports of Associations, Shows, Meetings, Echoes from the Hives, Queries, &c., are requested to direct their communications to 'The Editor of the "British Bee Journal," c/o Messrs. Strangeways & Sons, Tower Street, Upper St. Martin's Lane, W.C.'

#### OUR HONEY IMPORTS.

The value of honey imported into the United Kingdom during the month of July, 1884, amounted to 10,089*l.*—[From a private return sent to E. H. Bellairs, Esq., Wingfield House, Christchurch.]

#### THE LIVERPOOL SCHISM.

As every one appears to know how to conduct your *Journal* better than yourself, and to think that you require advice not unmix'd with censure, I also venture to make some observations on the manner in which you have dealt with the 'Liverpool Schism,' which will not be in the least accordance with the half-hearted expressions of Mr. E. H. Bellairs. I believe, sir, that you know the nature and extent of the evil which you have attacked (*in my opinion not one whit too vehemently*) better than one who has only recently joined our ranks, and is, so to speak, a junior amongst county secretaries. The trumpet of the *Bee Journal* has certainly given forth no uncertain sound in this matter; and I, in company with many of your readers, thank you, sir, for dealing with the case so vigorously before the cloud which seemed no bigger than a man's hand had grown into a hurricane. In my opinion the Committee of the B. B. K. A. have done all that it was possible for a committee to do; and I know of no committee which holds its meetings with greater regularity or gets through a greater amount of work. I wish that some of its detractors would state openly what *more it could have done*. I hope that it will continue its unselfish and disinterested labours for the public good through evil report and good report, and that you, sir, will not fail to speak out boldly whenever the occasion seems to demand it, and not allow so useful and excellent an Association as our own to be undermined and broken up without giving us warning of the shadows which coming events are casting before them.—AN OLD COUNTY SECRETARY.

#### CONDEMNED BEES AND HOW TO MAKE THEM PAY.

Once more I must crave your kind indulgence to correct, what experience has taught me is a great error in the advice and instructions given by your correspondent under the head 'Condemned Bees and how to make them pay.' First we are recommended when we reach the place where the bees are to be driven, 'to smoke all' and close all the entrances to the hives with a wisp of grass, whether they are to be taken or not. I have not forgotten the lesson learnt by me when following this same advice given to me some few years ago, when I found my bees (though only closed up from ten minutes to a quarter of an hour) most of them stifled on the floor-board. For it is only natural for bees, when smoked, at once to rush to their cells and gorge themselves with honey; by this undue excitement greater heat is of course generated in the hive, and the bees being unable to fly and get the ordinary ventilation owing to the entrance being closed, must of necessity get overpowered and stifled, neither is there any provision made for the bees returning from the fields during the time the driving and cutting are going on. These the operator would find



greater nuisance than the few that would be attracted by the smell of the honey if left undisturbed.

Secondly, the writer of that article does not recommend driving; but taking the hive from its stand he rumps it on its side, the flat way of the comb, as 'broken combs bleed far less than cut ones.' As regards bleeding, I am willing to admit that if a comb is properly broken it will bleed less than a cut one, but your correspondent seems to have forgotten that the majority of skeps taken from cottagers have cross-pieces of wood through them, and at any time the tendency of combs is to break about two inches from the top just where the brood-nest commences. How are these to be got at without first driving the bees? The consequence of this cropping business would be to break your comb in various places, which must of necessity smother the bees with honey, no matter how careful an operator may be. An illustration of this smearing business may be seen at many of the local shows when skeps have been bought for manipulation by the expert with combs broken down. The operator would find it much better to first drive his bees by the method recommended in *Modern Bee-keeping*.

After having driven the bees, he should take a pair of nip-pers or pliers and draw out the cross sticks, then use what is technically called the 'slop knife,' that is, a double knife that cuts at each end, and is made thus, the flat or narrow,



The end A is used to push down between the ends of the combs and the slop side, B is so turned as to cut between the crown of the hive and the comb tops. The combs may then be placed in any receptacle, and taken away without any loss by bleeding, and no honey will be dropped about to cause robbing. G. J. BULLER, *Wicham, Herts.*

We have received a communication to the same effect as the above from Mr. W. T. Joyce, of Farnborough.]

#### ADULTERATED HONEY.

Mr. Otto Hehner, in his able paper on adulteration of honey, says he is not aware of a prosecution case for adulteration having been tried. If he turns to the November number of the *B. B. Journal* of 1877, pages 117 and 122, he will see we had a case brought to trial in Glasgow, in which the vendor (a grocer) was fined 2*l.*; and again it is alluded to in the December number, 1878, page 142. The result of these prosecutions has been that you cannot buy a pound of American honey in Glasgow now, or since that date, even though you would. No grocer will touch it, and a large produce broker dropped two tons at that date sent from Chicago. We have long held that there is no necessity to import spurious honey to our country; only teach our young people to handle bees, and we might export it, instead of importing thousands of pounds sterling per month to Britain. R. J. BENNETT, *Hon. Sec. of the Caledonian Apian Society.*

#### A SECOND CROP OF DRONES.

At the end of May I had a hive with a last year's queen full of brood, worker and drone, on eight bars, 15 ins. by 11 ins. I increased them to eleven bars during June; July being broken weather, and they having gained nothing in June, I had to feed regularly. During July they turned out all drones mature and grubs. The hive has now got lots of brood, both worker and drone in all stages. As honey is now coming in very fast, I have removed three combs and put on supers. One of

the sheets of foundation put in in June has two queen-caps, but they have not swarmed; they are black bees. —R. H. C., *Aug. 21.*

#### DESTROYING QUEENS WITH A VIEW TO PRODUCE HONEY.

On this point it may interest your readers to hear of my experience this year. I commenced the year with two rather weak bar-frame hives, but with careful feeding and warm weather in March, No. 1 became quite full of bees by the beginning of May. No. 2, a swarm of last year, became full by May 24th. On May 19th I put a super with seven bar-frames partially filled with comb and foundation on No. 1. On May 24th I put three 2-lb. sections on No. 2. On June 9th I killed the old queen of No. 1, and on June 23rd took away all the young queens except one. By use of the honey-slinger and an enormous population, this hive has yielded over 66 lbs. of finest super honey. No. 2 I treated in much the same way, killing the old queen when she swarmed on June 22nd, and returning the bees. This hive has yielded over 53 lbs. in two supers standing side by side, besides some 20 lbs. still untouched in the brood nest. I may say that I tried the same plan of sacrificing the old queen four years ago with nearly the same result. Then the queenless hive gave me over 40 lbs. of super honey, whilst two others nearly as strong only gave me 20 lbs. between them. No. 1 hive contains eleven frames, a size of my own, smaller than the Woodbury. No. 2 contains fourteen frames of the same make. I should much like to see the experience of those who are experienced in bee-keeping on the above mode of treatment. —P. W. G. F., *Clifton, Aug. 1884.*

#### BEE'S TRAVELLING FASTENING CHESHIRE RAKES ON THE COMBS.

Many thanks to you for the insertion of the remarks I forwarded bearing on the 'Travelling of Bees' mentioned in 'Useful Hints,' and also to the writer of that article (whoever that may be) for his promptness of reply. I have more than once followed the advice given by him, viz., 'to use my eyes,' and if he will go and do likewise, and walk along-side the cart as well as behind it, he will see plainly that by far the greater portion of jolting is from back to front. Hence my reasons for travelling the bars at right angles to the axle.

I may mention that it is a difficult matter to find the ideal man he speaks about, and that every driver of a cart is not so careful a man as the writer of 'Useful Hints' appears to be, and that he ought to know, if he has ever had any dealings with them. That very careful driver that he speaks of should, of course, guide his horse so as not to allow his wheels to bump over a big stone nor run into a hole. Again, he says, 'that a horse with bees behind him should never go beyond a walk.' This slow mode of travelling, I need hardly say, would come in very expensive to those who have a large number of stocks to travel and a long distance to go. When packed in the way I recommended, I have not only trotted, but have even galloped the horse, when pressed for time to catch a train, without a single comb giving way.

In these days of cheap railway travelling, I can only imagine that the writer of 'Useful Hints' has not his sense of feeling quite so highly developed as he would have my sense of vision to be, or he could not possibly have failed to notice the vast difference between the easy sway of a railway carriage as it rounds a curve to the violent jolt that is so often experienced at the starting and stopping of a train, when one suddenly finds his head rather too close to the traveller opposite to his pleasant.

As the 'proof of the pudding is in the eating,' so it is with the travelling of bees; and as I have frequently

seen combs broken down when travelled parallel with the axle, and never once when packed and travelled in the manner recommended by me in your last issue. I can only again proclaim the merits of my system, as it is one not of theory gained by sitting at home reading, but is the result of practical and dearly-bought experience.

Trusting, Mr. Editor, you will insert the above in the spirit in which I have written it—not as fault-finding, but with an earnest wish to be of some use to the readers of your most valuable paper, and that they may never experience the expense and annoyance that I have experienced through bees travelling with their combs running parallel to the axle.—G. J. BULLER, *Woburn, Herts., August 19th.*

[In connexion with the above, we have received a letter from Mr. H. Anstin Ellis, of Castlegrave, York, not so much bearing on the question in issue as furnishing his testimony of the high ability of Mr. Buller as a bee-keeper. This is not required; for the experience and intelligence of that gentleman are known to all who have come in contact with him. The moral to be drawn from the correspondence is: Pack your travelling bees in such a manner that they may be secured from the effects of jolting either by road or rail.]

#### A HONEY-MARKET FOR IRELAND.

The bees are among the blooming heather with naught to disturb their joyous hum but the sound of the sportsman's gun and the crow of the grouse cocks. Everywhere abounds with honey, sealed sections, and well-filled skeps. The general cry is, 'Get us a market for our honey.' You show us how to get honey upon improved principles, and here we have tons and can't dispose of it. We have not reaped much benefit from the Associations here: what little we know is from the *Bee Journal* and the publications of the British Bee Association. Several have written to the Irish Bee-keepers' Association about selling honey, but were unable to effect sales through their agency. I wish my fellow bee-keepers to know that arrangements have been made with a respectable firm in Dublin to sell all the section and comb honey in Ireland. Sections are to be securely packed, and none but well-sealed ones sent. In the case of skeps, bulk must not be broken, but all placed securely in crates and packed between with clean damp moss or cabbages. All sections must be packed in damp paper, and put up neatly, and all parcels marked: 'Perishable: Immediate'; and forwarded carriage paid per goods train to the different stations. Spring vans will be sent on receipt of advice-note from the country. Bee-keepers must state all they know about their honey, and empower Mr. Patrick McManus, 29 Capel Street, Dublin, their factor, to sell at anything over a certain sum. The honey will be sold and cheques forwarded for amount. I would impress all to write plainly and address legibly.—J. TRAYNOR, *Tinaboly, Ireland.*

#### ANCIENT REFERENCE TO SMOKING SYRIANS.

The extreme gentleness of Syrian bees, and their fierceness when smoked, have been several times spoken of in this *Journal*. That these characteristics were known from very early times is curiously shown in a reading of Deut. i. 44. Moses there compares the attack of the Amorites to that of bees which came swarming out of the cracks and crevices of the rocky hill-side to punish the invaders. His words, as given in the ordinary Hebrew text current in Palestine, are, 'The Amorites which dwell in that mountain came out against you, and chased you as bees do;' and if the Holy Land bees deserve their reputation for savageness the words would convey a very lively significance to the dwellers in

Palestine. But, on the other hand, if the Syrians deserve their reputation for docility, the simile would fall very flat upon the ears of those amongst the later Jews who had been born and bred in Syria. For according to Mr. Hewitt and others, one might scramble about the cliff the whole day long and never a bee so much as buzz, unless perchance the smoke of a camp-fire blew along the face of it, and then was to the luckless intruder. And so the Syriac Version reads, 'Chased you as bees that are smoked.' As far as I am aware the addition is peculiar to the Syriac Version, and is found nowhere else except in a single Arabic MS.—T. L. W.

#### HORIZONTAL COMBS.

Having seen in the *British Bee Journal* for July 15th Mr. J. Hewitt's account of finding brood in horizontal combs, if you think the following worth inserting and can find room for it, it may interest some.

In the beginning of June of the present year, while out for a walk, I chanced to pass by a large farm-house well surrounded by a very high hedge, I fancied I could hear the hum of bees. Walking a little further, I met with one of the farm-servants—in fact, just the right man, for upon inquiry as to whether any one kept bees hereabouts, he said, 'Yes; we've some in the garden. Should you like to look at them?' Of course I could only make one answer—'Yes.' So into the garden we went; and I was not long before I found the bee-house, a structure made to hold four straw hives, but with only one occupied at one end. On trying to lift up the lid I found it fast; but with the help of the man I raised it up a little, when what was our surprise to find a mass of comb and bees adhering to the lid, and as vicious at being disturbed as bees well could be. We had to leave them then, but in a few days I had a call from the gentleman, asking me to go and take him the combs out of the shed. I could not go for some time, so I advised him to put a straw super on. A fortnight afterwards I went to cut them out, when I found they had filled the super full of brood, and had built combs that covered a very large meat dish in the roof of the shed reaching down to the mouth of the hive, a distance of 2 ft. 6 ins., and all the lower parts filled with pollen; and from hive No. 1 to hive No. 2 were built two combs, attached to the side of the shed and to both hives in nearly a horizontal position. These also were full of pollen, and not through any accident, but built naturally. I placed a crate of eighteen sections on top, also the straw super containing brood; from which I have since cut all the comb, and it is full again, as also are the sections.—R. S., *Swarwick, Alfreton, Derby.*

#### PHENOL A CURE FOR 'BACILLUS ALVEI.'

From your article in the last number of the *B. B. J.* many of your readers would infer that Mr. Cheshire had communicated nothing new to bee-keepers in the paper which he recently read at the Conference at the Health Exhibition.\* Now, Sir, if indeed Mr. Cheshire did not in the first place suggest phenol either as a preventive or cure for *foal brood*, there can be no doubt that he first fully saw the enormous value which this substance, when

\* We have a higher opinion of the intelligence of our readers than to conceive that 'many' of them would deduce such an inference from the article referred to; more especially so when taken in connexion with our previous editorial, which mentioned the significance, extent, and effect of Mr. Cheshire's investigations. It is scarcely necessary to state that the article adverted to by our correspondent was designed to be, simply and purely, historical. It is interesting, and also instructive, to note the genesis, the progress, and the development of a discovery; the more so when its course is traceable, as in the present instance, through several nations and peoples.—Ed.

properly used, would prove to bee-keepers. Had indeed the other gentlemen you name been fully aware of its value, do you not think we should have heard more about it?

Signor Grassi, I see from Captain Danyell's letter, does mention *acids phenica*; but the considerable *minuteness* of detail in his description to which you refer is *wholly* devoted to the use of salicylic acid. Moreover, phenol is suggested here only for washing purposes; and then as second to salicylic acid, which the writer says it may replace on account of its being cheaper.

Phenol has however been shown by Mr. Cheshire to be immensely superior to salicylic acid; and here we have experimental corroboration of an inference to be made by any one well acquainted with the general properties of phenol and salicylic acid.

The thanks of all bee-keepers are due to Mr. Cheshire, not only for his very able, interesting, exhaustive, and original researches upon the true nature of the disease, but also for the cure he has placed in their hands; and here I refer more especially to those formulae which he has published. In less scientific, careful, and experienced hands than those of Mr. Cheshire, phenol would have been immediately discarded, owing to the difficulties and want of success which must necessarily attend first experiments in a case of this kind; but with a knowledge of the benefits derived from its use in other cases of germ diseases, and with that perseverance which characterises the truly scientific man, Mr. Cheshire has successfully carried on and completed his work, and has thus rendered powerless one of the worst enemies the bee-keeper has as yet had to contend with. JOHN M. HOOKER, *Sevenoaks, August 23rd.*

#### PHENOL.

Allow me to inform H. F. that neither he nor any other sufferer has any need to attempt the calculation of 'one part phenol in 500.' The cure for *Bacillus aerei* as prepared for sale under Mr. Cheshire's guarantee is a simple measure, which has to be diluted according to the directions and added to a certain quantity of syrup, which then becomes medicated to exactly the degree which Mr. Cheshire has found to be the best. If people will get themselves puzzled by purchasing 'Phenol' of unknown strength from dealers, they cannot expect Mr. Cheshire to help them out of the trouble of their own making, especially under the circumstances referred to by him in the concluding portion of his letter, p. 277. F. LYON, *Harleyford Road, 15th August.*

#### STRANGE LOCATION OF BEES.

On Saturday, July 26th last, being desired by Mr. J. Siddons, of Oundle, to accompany him to Overstone Park, for the purpose of taking, I cannot say a swarm of bees, but a stock that had taken, or rather were in possession of five combs, 11 inches long in the centre, and 7 in the two outside ones, one of which bore evidence of having contained brood; the inside combs were well stocked with eggs and brood (which are hatching, or have hatched, out in a bar hive, to which they were transferred to build up one of my stocks; the stock weighed about 6 lbs.; the combs were walled down at the ends for protection, and contained not more than 2 lbs. of honey altogether. On the first sight of the chive-tree they gave the idea of a large fungus, being about 12 feet from the ground, and had the appearance of being dead, but on nearing them they showed evidence of life. My *modus operandi* to take them in as perfect a form as possible was to well spray them with syrup (a smoker being not much used), was by placing a flat wool skewer through the whole; this had to be done rather cautiously on account of the combs being new, very soft, and also tender; and wishing

to take the queen if possible after this, with a knife the whole was cut from the tree as close as possible; this I succeeded in doing, but in taking it down the ladder it came to grief and fell on the grass, or it would have been preserved intact, as I think it unprecedented in the annals of bee-keeping in this country. After this mishap the bees were driven from the grass into a (four-frame standard size) swarm-box, having first secured the queen in a cage, which was placed inside. The swarm-box was hung under the arm of the tree in as near a place as the original comb stood, and the bees have taken possession, the entrance was closed, and so ended this singular hiving of bees; and must add, the queen is of the usual blood. We have in this district strong hybrids, as to whether they are what may be called wild bees, I think not, as those I have seen about this district are small and intense black; my only conjecture is, they swarmed in the district during one of the very hot days we experienced here the end of June. — JAMES DAVIES, *Northampton.*

#### VAGARIES OF THE QUEEN.

W. Crisp says, July 15, p. 209, 'I upon several occasions have seen a queen come out and circle about for a few minutes and run in again.' I have been perplexed by the following facts, which I think bear out what Mr. Crisp says:—On May the 14th I took a swarm of a hive and gave it a queen. A few days after I examined it, saw the queen, eggs and brood in various stages of existence. In June, before putting in the supers, I examined it again very carefully. I found no queen, no egg, and but very little sealed brood. A few days after I asked a friend to assist me. We found no queen, no egg, no brood. I then bought a Ligurian queen to introduce, but before introducing her I thought I would examine it once more, when I found a patch of eggs about the size of my hand, and in the next frame a fine queen.

All my hives are Ligurian except one, which are condemned black bees that I took last autumn; they were very strong, so I divided them, taking five frames with the black queen, and placing them on a stand about six feet off and introduced the Ligurian to the hive on the old stand. I have not examined that hive since the third day after the introduction of the queen, when she was all right. Today I notice a lot of Liguarians on the entrance-board of the hive which contained the *black* queen, but not one from the hive which contained the Ligurian queen. Is it possible that the two queens have exchanged hives? — WALTER, *Wardle.*

#### TOAD AND BEES.

Last evening I discovered a toad mounted half way up the flight-board of one of my hives, the only one I have that stands on the ground. It has 8-inch runways beneath, with the ends cut at such an angle as to give the flight-board a depth of fourteen inches. I had not watched many seconds before the reptile began to ascend; and placing himself opposite the group of bees at the entrance, waited till one approached, when as quick as thought it was entwined in the reptile's maw. The toad then retired to near the bottom of the board, when a bee accidentally or intentionally settled upon it, and apparently pricked it, as I never saw such an exhibition of activity on the part of a toad as during the next few seconds. After several minutes, it again mounted the board, and this time took a bee off the hive above the flight-hole; but was evidently stung in the mouth, for he made several gasps and rolled the right eye about in a most ludicrous manner, forsaking the flight-board and presenting a most pitiable appearance. Having waited till my patience was exhausted without his making any further attacks, I secured him.

killed and disembowelled him, and extracted one wasp and five bees quite recently swallowed, and lower down the hard remains of several beetles. I assure you, Sir, I shall make no more hives with flight-board resting on the ground.—THOS. H. HART, *Park Farm, Kingsnorth, Ashford, Kent, August 12th.*

#### INTRODUCTION OF AMERICAN HONEY.

(From the 'New York Sun,' July 7th.)

"Another large bee-keeper is C. R. Isham, of Peoria, New York. Up to 1879 there was no market in England for American honey. The English dealers would not handle it, and the periodicals devoted to the interest of bee-keepers in that country cried it down in every possible way. The reason for this was that they knew the superiority of American honey, both in flavour and appearance, over the British article, and were aware that if it was once introduced in London it would be a great blow to the trade in the home supply. There was a smart Yankee named Hoge, working for a grocery in this city, and he assured his employers that if they would give him the commission, he would manage to place American honey on the English market. A large lot of Isham's honey, which the firm was then handling, was packed, just as it came from the hives, and Hoge was sent to London with it. He found he needed all his Yankee ingenuity and acuteness, for he met with universal opposition among the dealers. He laboured with them for weeks, to no purpose. In conversation one day with the proprietor of a hotel at which he stopped, the latter told Hoge that if he could manage to have his honey introduced on the table of Queen Victoria it would solve the problem at once, for if she was pleased with it she would communicate to Hoge through the Lord Steward. This communication once made public would make American honey the fashion in England.

"A former Lord Steward was a friend of the hotel-keeper, and was at that time engaged largely in the manufacture and sale of pickles. This man the landlord introduced to Hoge. They dined together. Hoge gave the pickle man an immense order for his goods, to be sent to an American grocer. More wine followed, and before the ex-Lord Steward went away he promised to use his influence to have the American's honey introduced on the royal table. He succeeded in inducing the then Lord Steward, Sir John Cowell, to accept a box of the honey for the Queen, and to serve it on her table. The Queen was so delighted with the honey that she directed the Lord Steward to present her thanks to the donor, to order a supply of ten cases at once, and to keep American honey constantly on the royal table.

"Hoge lost no time in making this communication public. The consequence was that the opinion of American honey changed at once, and Hoge came back to New York secretly laughing at the Britishers, but rejoicing over an order for a half a million pounds of American honey for the English markets, which he carried in his pocket. The demand for it has increased ever since, and the trade that was started in the New York State honey is now largely shared in by the California product."

[The *American Bee Journal*, while giving insertion to the above, states that, though this narrative is not absolutely correct, there is a considerable medium of truth in it. The 'Anxious Inquirer with a Sore Throat,' who, from a recent communication, we regret to learn has not quite recovered from his complaint, will perhaps be kind enough to find an answer to his inquiry in the above extract.]

## Echoes from the Hives.

*Wisbech.*—This has been a very good season for honey gathering in this district. The slinger has been busy at work, and sections have been plentiful, well filled, and fairly well sealed, and the honey of very good quality. I took off seven sections well filled and sealed as early as the 30th of May, and on the 11th of June I took from the same stock a crate of twenty-one 1-lb. sections all well filled and sealed. On the 2nd of June I found that several of my stocks were so full of honey that the queens had scarcely any room for egg laying, that I thought it best to use the slinger, and extract a few bars from each. I obtained 25 lbs. of beautiful honey. Then came dull and showery weather for a few days, and gave the queens a chance of filling the combs with brood, which they did, and made the stocks strong, so that I took off sections and used the extractor in earnest. I have taken from one bar-hive sixty-five 1-lb. sections, and slung from another box 80 lbs. of honey. So great was the honey glut in July that I slung from a bar-hive 35 lbs. of honey on the 1st of July, and again on the 7th July I slung 30 lbs.; and from five stocks I have taken 127 sections, and slung 122 lbs. of honey, and on the 24th June I had a very fine swarm from one of them, which now has well filled a large skep.—J. DANN.

*Springfield, Essex, August 20.*—As I anticipated (Echo June 1st) the supply of honey in this immediate neighbourhood has been very moderate, the extraordinary drought which we have experienced on this light but good land, throughout the spring and summer, has completely dried up our herbage, including the white clover which we so much depend upon: our stocks, as I reported at the time, were very strong, but so far as my apiary is concerned I have three hives which have not produced an ounce of honey, two of which have not, I think, ever swarmed; since the 20th of July my bees have been pressed for food, my hives are so poor that I have commenced slow feeding. A strong swarm, hived on June 28 in a ten-bar Woodbury size hive, has not, with the assistance of 16 lbs. of sugar, built out the combs. Reports from moderate and heavy land districts are good. Wasps are very numerous and troublesome.—G. H. AUBREY.

*Sheffield, August 27th.*—The past three weeks the bees have done wonders at the heather, sealing their combs with honey down to the bottom, and even to the entrance; the result is, queens are crowded out and hives are too heavy to winter. The weather seems changed now and nothing doing again; even if we get no more, '84 must and will be long remembered.—J. HEWITT.

*Ireland, Bray, 25th August.*—We have had the finest and driest summer known here for many years. Though the spring was very cold and late, the weather was fine when the clover came into flower, and from 12th June to 7th July the bees gathered an immense quantity of honey. We then had showery weather till about 1st August, when warm, dry weather again set in; but with me the bees did not gather much surplus until the 17th inst., when they suddenly began to gather heather honey in quantity. The heather they are working on must be at least two and a half or three miles distant, as that which is nearer was dried up and out of flower long before. Another gentleman at a considerable distance from heather, in another locality, also found his bees beginning to gather from the heather on the same day. Mr. Pettigrew, in his *Handy Book of Bees*, says, "They never find the hundreds of acres of heather on Carrington Moss, only three miles distant." The cases I have mentioned, however, I think tend to prove that bees, when once they have found the heather, even though three miles off, will work well, and fill supers from it.—E. D'O., jun.

## NOTICES TO CORRESPONDENTS &amp; INQUIRERS.

F. HUG.—The comb and bees you forwarded have been submitted for examination, and both have been found to be perfectly healthy.

G. R. DISS.—*Ginger-beer plant*.—Your letter has been forwarded to Mr. Ingram, to ascertain the specific name of the plant. In the meantime a kind friend has forwarded to us a small portion, with instructions as to its use. It evidently is a fungus, and as such bears some resemblance to the vinegar-plant. It appears to have been brought by a gentleman of the name of Surtees from India, and by division and growth has been distributed over a large portion of Hertfordshire. There is no fermentation, and it has been analysed and pronounced perfectly good for use. We can well believe that if honey is mixed with it, a most refreshing beverage will be the result. If any further information is required we shall be happy to furnish it.

A KERRY BEE-KEEPER.—*Extracting*.—You can extract the honey from your combs by using a cage, which is supplied with most extractors for the purpose of containing loose combs not in frames. If you are not inclined to go to much expense Abbott's Little Wonder Extractor would suit you, but it is rather hard work to use it. There is such a large variety of higher-priced ones, that we can only advise you to consult our advertising columns.

H. JEANES, *Kilnington*.—1. *Bees in a Porch*.—Smoke them and drum on the boards for a minute or two, then remove the boards, cut out the combs and the them into the frames. Brush the bees out the best way you can and find the queen, get her into your hive; place it near the old nest and the other bees will soon join her, when you can put the hive on its stand and repair the porch. If you leave any hole, probably another year a swarm will again take possession. On no account use chloroform. 2. *Sugar for Syrup*.—Either of the two samples of sugar forwarded may be used for making syrup; but they are not those which we would recommend as the best for the purpose. We prefer the refined crystallised sugar, which contains saccharine properties 997. Mr. Simmins advises the use for dry sugar feeding of Porto Rico, or the best grades of Demerara. For recipe for autumn feeding see *Cowan's Guide-book*, fourth edition, p. 152.

B. FLATMAN, JUN.—1. *Bacillus*.—Your bees have been placed in my hands, and I find them badly infected with bacillus, which I am all but positive is *alvei*, the bacillus of foul brood. If so, your case is but one of many I have traced out in which the bees are suffering from the disease whilst the brood has, up to the present, immunity. It may be that as breeding time is drawing towards its close, this partial attack may pass without assuming a serious phase; but should decaying brood be seen, you now know, as a reader of the *B. B. J.*, the method of procedure, when a little care will make a cure certain. I should advise, however, immediate treatment, which can but be beneficial, purchasing your remedy either of Mr. Lyon or Mr. Hollands. In due course I shall have the opportunity of explaining the additional and absolute proofs which have been now secured, that foul brood is caused by the bacillus *alvei*. 2. *Killing Bees for Mounting*.—The very best way of killing bees for mounting as specimens is the one adopted by the late Mr. Smith, of the British Museum, in which the insects are exposed to the fumes of burning sulphur in a small box, which is not opened for eight or ten hours after the operation. The limbs will then be found perfectly plastic, admitting of any desired arrangement. A large pin is now put through the thorax, and stuck into the face of a big cork, while

the legs are set by smaller pins, which temporarily hold them until they are set, when they (the pins) are removed. Or the bee may have a pin or needle thrust from beneath into its thorax, the instrument of destruction having first been dipped into corrosive sublimate dissolved in water. The central gash in being reached by the deadly poison, death is very immediate.—F. C.

M. O.—We are pleased to inform you that the comb forwarded is without any symptoms of foul brood. The cells are full of pollen.

LINCOLNSHIRE BILL.—1. In Mr. Cowan's *Guide Book*, 4th edition, p. 117, you will find instructions as to the introduction of queens. 2. Refer to our advertising columns for dealers supplying queens. 3. We see no reason to apprehend foul brood from your mode of action.

W. B. JAMES.—*Wasp*.—If your bees are, as you state, too 'sleepy and languid' to defend their stores you had better place by the side of the hives a counter-attraction. Dr. Butler (*Feminine Monarchie*, edit. 1834) says: 'Set by them Sider, Verjuice, sour Drink, or Grounds, in a short-necked Vial open, or other Glass, covered with a Paper that hath a hole in the middle; and so you shall catch many.'

OSOKO. 1. *Fruit-juice*.—The fruit-juice if sealed is not likely to ferment. 2. *Meal*.—You can extract the juice and the honey separately by not removing the caps from one while extracting the other. If, however, they are mixed in the same cells, of course you cannot do so. You can make good meal of the mixture, recipes have appeared in the *Journal*, Vol. XI, pp. 125, 128.

Mrs. MAY.—*Queenlessness*.—Your stock which swarmed three times was queenless. No doubt the surviving queen got lost in her wedding flight. The queen-cell you will most likely find empty, the lid having closed after the exit of the young queen, or it may contain a dead queen. The swarm also lost its queen by some means, possibly she got smothered when the combs broke down. The Ligurian robbers soon discovered the weakness of the stocks and commenced robbing. There was no desertion of the hives, merely weakening from queenlessness.

G. SPENCER FISHER, *Epsom*.—The parasite forwarded is the *Braula coeca*, or blind louse. As many as fifty have been found in a queen. In the northern part of Europe and in England, they disappear, the climate not being favourable to their existence. Queens have been watched with several of them on her, but she does not appear to be incommoded by their presence. This is the second time inquiries respecting this parasite have been made from your locality. See *Bee Journal*, Vol. X, p. 279, for description of the *Braula*.

W. C. WALLACE, *Dumarton*.—*Beginning Bee-keeping*.—We should think bees would do very well in your district, and advise you to read *Modern Bee-keeping* (price 6d., sold by Mr. Huckle) and Cowan's *Guide-book* (price 1s. 6d.). Begin with a couple of hives first and find your way. Several Scotch firms advertise in our columns. We cannot select for you.

J. E. YONGE.—As you have so decided an objection to bees, we would not recommend you personally to attempt to remove them from your roof; but there is no doubt that if you apply to either of the secretaries of the Devonshire B. K. A., Mr. Griffin or the Rev. J. Dangar, or some expert in the neighbourhood, they would feel a pleasure in assisting you in getting rid of, what is to you, so great a nuisance.

J. W. BATECKLOR.—It is not an uncommon practice for bees to remove honey in supers to the body of the hive; and for some purpose of their own the bees have done something similar in your hive.

ISAAC WATTS.—*Transferring*.—As soon as the season is over your bees might be transferred to bar-frame hives. As to the best mode of doing so, consult Cowan's *Guide-book*, p. 132. As you appear dilident of your ability, it would be desirable to have the assistance of a companion. What-ever is good of the old comb might be utilised, supplementing with foundation comb.

R. WOODWARD.—1. *Condemned Bees*.—If you would get twelve bars out of your eight hives, and put the condemned bees in two hives with six bars in each, you would then get two good extra stocks. Be careful to save the youngest queens only to head these stocks. 2. *Foundation*.—It is preferable to give full foundation sheets, taking care that they are securely fixed in the frame.

W. BUNTING.—1. *Frames across the Entrance*.—We prefer, for reasons stated in previous numbers of the *Journal*, the frames being placed across the entrance, as in Abbott's Combination hives. 2. *Width of sides of Frames*.—Making the sides of your frames  $1\frac{1}{2}$  inches and letting the top bar in, would constitute your hive practically a Giotto hive, which has been tried by many bee-keepers, but has been discarded by the majority of them, as being most difficult of inspection. 3. *Thin-ning Honey*.—This might be done by stirring well in hot water—or, perhaps, warm syrup would be preferable.

BEGINNER.—If, as you aver, your hive was so closed that no bee could possibly get out, it would follow that the bees seeking an entrance in the morning must have stayed out all night. But this conclusion is quite contrary to the home-coming instinct of bees.

AMATEUR.—*Painting Hives*.—The special colour for painting hives is a question for individual taste rather than of bee-culture. We prefer some light colour. Tar is very useful in coating hives to render them rain-proof. See *Moderate Bee-keeping*, p. 24.

MRS. BEDDOE.—The portion of comb forwarded was not infected with foul-brood; the cells were filled with pollen or bee-bread.

ELIZABETH MUNDAY.—*The Queen Failing*.—We advise you to become a member of the newly-formed Middlesex Bee-keepers' Association, which in the course of the coming year will probably have the assistance of an expert, whose visits and advice you will be entitled to receive. Bees ought to do well in your neighbourhood. When the queen failed a young one should have been introduced. As it is, you will be compelled to start again. Either procure driven bees and introduce to your hive, feeding them freely, or wait until next season and purchase a swarm.

K. WARRELL.—*Storage of Honey*.—Tin or metal receptacles of any kind are the worst for the storage of honey. The wooden crates, with glass sides, as represented in Cowan's *Guide-book*, Fig. 50, p. 54, last edition, are the best for storing sections. These, when filled, are placed in a dry room or closet, at a temperature of from 50 to 60° Fahr., will keep sections in perfection. At the present time we are eating some of last year, which we defy any one to distinguish from the finest of this year's produce. Granulation, however, depends very much on the sources from which the honey is collected. Honey collected from mustard and some other plants crystallises almost immediately it is gathered. When this takes place it is best to melt it over a slow fire, skim off the wax, and store the honey as extracted.

A. W. WALLACE, *Parsonstown*.—1. *Bee Literature*.—We recommend you to procure Cowan's *Guide-book*, fourth edition, 1s. 6d., supplied by Mr. Huckle, Kings Langley, Herts, where (2) you will find bee appliances advertised, as also in our own columns. We cannot under-

take to specify particular firms. 3. *Driven Bees*.—Yes; September will do very well for building up colonies of driven bees, but it should be done in the early part of the month. It is not necessary to remove the queens; the bees themselves will do this. Drive each colony into a separate skep. Sprinkle the bees with a little thin, scented syrup, and shake the two or three lots into one skep, shaking them well together, and then turn them out on a sheet in front of the wedged-up hive they are intended to occupy. This operation is best performed in the evening. 4. *Transferring*.—Yes; you can do as you propose, which is simply called 'transferring,' keeping back the heaviest and best parts of the comb-honey for sale or otherwise. 5. *Italian Queens*.—We advise you not to attempt changing queens before another season, when Italian queens will best suit your purpose.

M. A. D. PRITCHARD.—1. *Uniting Stocks*.—Now is the best time to unite stocks. Smoke both and spray the bees with thin scented syrup giving them a few minutes to lick it up and acquire the scent. Remove the queen of least value. Lift out the combs from one hive and put them to the other keeping all the brood of both lots in the middle of the hive. Put the hive on a stand midway between the former positions and remove the empty one quite away. 2. *Driving Bees*.—No. You are not likely to drive the bees up by smoke. Take off the top hive which will probably be filled with honey. If any combs contain brood put them into the lower one. 3. *Ivy Honey*.—When the ivy blossoms the bees gather a good deal of honey of a cheery consistence from it which is an acceptable addition to the stores.

J. M. S. PHOEN.—Not unless *Bacillus alvei* is present. 2. *Winter Packing*.—No. Chaff is preferable to flock which is very liable to harbour moth. 3. *Fruit-Juice*.—'Onoko' has informed us that our explanation of the appearance of fruit-juice in his hive was correct. The bees obtain honey from raspberries of a very sweet flavour. 4. *Henlock*.—The bees may have been getting pollen only from the henlock. If they have obtained honey, it does not follow that it is poisonous. It is frequently the case that one part of a plant is poisonous while another is not.

F. A. JARVIS.—*Skeps*.—Since your swarm is established in a skep, you can do nothing more than protect well for the winter. Had it been in a bar-frame hive, you might have appropriated the outer combs, and closed up the division-boards to the six central combs. In the case of a skep it is not advisable to cut away the outside combs, thus creating a vacuum in the hive, and probably causing the death of your bees if the winter prove severe. The labourer who possesses twelve hives would do well to reduce the number to one half if he wishes to realise. Let him retain those which have given off swarms during the present summer, if well stocked with bees, as these will be headed by young queens. From those he 'takes up' the bees should be driven and united to those which are intended to 'stand round.' Procure a copy of *Modern Bee-keeping*, price 6d., and the penny pamphlet on *Skeps* from Mr. Huckle, Kings Langley, Herts, which will supply all the information you require.

J. G.—We are unable to inform you when Mr. Abbott's *Combination Hive, and How to Use it*, will be published.

Several communications and queries have reached us too late for insertion in the present number; among the former is a letter from Mr. J. P. Jackson, Editor of the *Bee-keeper's Record*, on the position he has taken with regard to the British Bee-keepers' Association. The discussion on Mr. Hehner's paper will also appear in our next.—G. H.

# THE BRITISH BEE JOURNAL

Communications to the Editor to be addressed 'SEABEWAYS' PRINTING OFFICE, Tower Street, St. Martin's Lane, w.c.'

[No. 151. VOL. XII.]

SEPTEMBER 15, 1884.

[PUBLISHED FORTNIGHTLY.]

## Editorial, Notices, &c.

### 'AUDI ALTERAM PARTEM.'

We think it a pity that Mr. J. P. Jackson should have ended his letter, which will be found on page 329, with such a terrible threat. We are, of course, quite terrified at it, but his letter would have been published in full without it. The only reason we can think of why the article from the *Record* which he alludes to should not have been published in full is, that our sub-editor could not find space for it.

Space seems to be more valuable in the *Bee-Journal* than it is in the *Record*, and we shall not therefore waste our space by defending ourselves against the charge of *embarrassing to stir up schism*, or '*trying to stir up schism*'. These are merely the '*To quaque*,' or 'You're another,' arguments which little boys employ against each other when they can think of nothing else to say. Nor shall we stay to discuss the question whether an interval of three days (the term of grace allowed by Mr. Huckle) is a measurable distance from a County Court or not. If we have done Mr. Jackson any injustice, we beg to offer him every expression of regret most unreservedly. We must not, however, allow the British Bee-keepers' Association to be aspersed without contradiction, and we must tell Mr. Jackson when we think he is wrong.

Mr. Jackson says that the North-western Confederation never existed out of our own brain. The information which we have received has pointed in a different direction, but we of course accept Mr. Jackson's denial. It is a pity that the course of action adopted by him should have led others beside ourselves into a very pardonable error. When a county secretary refuses to submit to the conditions of affiliation; will send no report or balance-sheet to the Secretary of the Central body; holds his annual meeting at any but the prescribed time; enlists his members from all the surrounding counties, from any county, it would seem, rather than his own; when in the organ of his Association he decries, and, as we still affirm, *attacks*, the Central Association, those who are anxious to preserve the unity of our system may well be pardoned if they foresee that schism and

separation will shortly follow. A separation there must necessarily be, for the conditions of affiliation will not allow an Association which does not comply with them to remain in affiliation with the Central Society. If a County Association will not submit to the very easy conditions imposed by the Central body solely for the advancement of bee-keeping, that Association must be regarded by the parent Society as though it had ceased to exist. And if the bee-keepers of that county disapprove of schism and separation, and wish to work in harmony with the Central body, the disaffected ones cannot complain if the well-affected are allowed to affiliate themselves with the Central organization. Self-government and independence in all internal affairs is the principle on which all County Associations have been founded; but as regards their relationship to the Central body, they must, if they wish to remain affiliated to their parent, submit to certain regulations and conditions. Mr. Jackson deprecates the idea of a North-western Confederation, but thinks that the County Associations should be *confederated* together and better represented at head-quarters. They are already *confederated* together with (not against) the Central Association for peaceful (not hostile) purposes. That they are not better represented at the Quarterly Conferences is entirely their own fault. Every possible facility has been given them in this direction. We have never seen any representatives from Lancashire at a Quarterly Conference for some time past.

Now to put Mr. Jackson right as to the history of the Lancashire Association. The *previous* Lancashire Association, which he speaks of as having died an abortive death, to borrow his own words, never existed out of his own imagination. It never existed at all. In the year 1879 the Rev. H. R. Peel and Mr. Baldwin visited Lancashire with the British Bee Tent at the invitation of the Rector of Halsall, the Rev. T. H. Blundell, and attended shows at Southport, Wigan, Ormskirk, and Maghull. Mr. Peel also obtained the consent of the Earl of Lathom to become President of a Lancashire (not Cheshire) Association. This was all that was done until Mr. Jackson came upon the scene. As soon as it was understood at head-quarters that an Association was being formed for both Lancashire and Cheshire, Mr. Huckle, then the Assistant

Secretary of the Central Association, was deputed to attend one of its first general meetings and induce Mr. Jackson, if possible, to confine his operations to Lancashire alone. The arguments which Mr. Huckle then brought forward seem to us at the present date to be sound and good. He explained that the system which the Central Body had adopted was to found an Association in each county, and urged that if the Lancashire Association wished to work in harmony with the British some deference should be paid to their views. He stated that the experience of the Central Body was that the boundaries of a county gave an Association a definite area within which to prosecute its work of instructing cottagers and artisans in bee-keeping, and that if an Association is confined to one county it is more likely to receive the sympathy and support of the resident gentry and clergy; and, lastly, he pointed out that the County of Lancashire was quite large enough for any executive to *work thoroughly well*. Mr. Jackson immediately made a speech of the *vehement* order against Mr. Huckle's proposals, which were never discussed by the meeting at all. The Central Association was thus repudiated and set at naught from the time of Mr. Jackson's connexion with Lancashire. The *Record* was soon afterwards started in opposition to the *Bee Journal*, and *defiance*, as we still maintain, became the order of the day.

But Mr. Jackson has written his letter in response to our challenge that he should verify two accusations which he has made against the Central Association: first, that its shows have been mismanaged; secondly, that its Committee is practically self-elected; and we must confine our attention to the proofs which he adduces upon these two points.

As a proof of the first statement, Mr. Jackson, without taking note of all the shows which have been held without any loss, since the year 1874, pitches upon two shows of the year 1883—the Knightsbridge and Bridgewater Shows—which were both held under exceptional circumstances. A large sum of money—18*l.* 1*s.* 3*d.*—was lost upon these two shows; but it was not through any mismanagement as far as the shows were concerned. On the contrary, they were two of the best shows of their respective kinds that we remember to have seen; but in both cases the British public would not pay their money to see a bee-show independently of any other attraction, and the receipts, therefore, fell very far short of the expenditure. The Fisheries Exhibition had occupied all the grounds of the Royal Horticultural Society. The Bath and West of England Society was too poor to offer any subsidy at Bridgewater. If the shows were to be held at all, they must be unconnected with any other exhibition. It was an error of judgment, as it turned out, to hold the shows at all; but an error of judgment is a very different thing from mismanagement.

But Mr. Jackson says that his best answer to our challenge is to refer to the present B. B. K. A. Exhibition at the Heatheries. 'There,' he says, 'is an example of mismanagement,' &c. Well,

we have visited the Heatheries also, and seen the exhibition in question, and find nothing to find fault with; but then we have looked through different spectacles to those which Mr. Jackson uses. So it appears, from his admirable letter to the *Times*, has the Rev. F. G. Jenyns, who certainly does not re-echo the wail of disappointment which Mr. Jackson speaks of. The show is as good as the Committee of the Central Association can afford to make it; and Mr. Jackson, having censured the Committee of the B. B. K. A. for losing nearly 200*l.* in 1883, is hardly consistent in blaming them for not risking a similar loss on a third show in 1884. Mr. Jackson certainly did nothing to make the show better. He was invited to contribute to the Guarantee Fund which was started by the Committee, but he took no notice of the application.

The second point which Mr. Jackson was challenged to verify was that the Committee is practically self-elected. How does he prove this statement? He says that if the existing Committee choose to vote for one another, each of them commands sixty votes. But does this prove that the Committee enter into an annual conspiracy amongst themselves to vote for one another to the exclusion of any 'outsider' to use Mr. Jackson's expression, who may wish to enter the Committee? The Committee certainly showed a disposition to admit outsiders at the beginning of the present year, when it was proposed to increase the number of the Committee from nine to fifteen members. Not a single member of the Committee raised his voice against the proposal. Not a single 'outsider' thus admitted received anything but a cordial and hearty welcome. We do not mind saying that we have always used our own four votes to introduce as much fresh blood into the Committee as possible, whilst retaining the services of those who have proved themselves good and faithful trustees of the Association. No Committee was ever less self-elected; and if the same members of Committee are returned so often, it is because the members of the Association have confidence in their old representatives, and think that they cannot be better served.

We think that we have now said enough to show that Mr. Jackson's charges are '*not proven*,' and we would again warn our readers against this attempt to insert the thin end of the wedge into the *constitution* of the British Bee-keepers' Association. We would further remind them that what Mr. Jackson calls the property qualification (which we think most essential to the maintenance of our organization) is always the favourite point which those who have evil will at us choose for their attack. Mr. Raynor has most lucidly explained the necessity for such a qualification in an Association like our own. When, therefore, we find a would-be member of Committee endeavouring to obtain election by attacking the 'property qualification,' the words of the old Latin poet will force themselves upon our lips:—

'*He riget est: hinc tu, Romane, caveto.*'





country this summer. This show will not merely be an exhibition of bees, honey, and appliances, but a unique feature will be introduced in the demonstration of the various utilities of honey, such as food, confectionery, medicines, and beverages,—a tangible and a visible sermon on the text, 'My son, eat thou honey because it is good.' We hope that there may be a large attendance of those interested in the development of the uses of honey, and thus testify their appreciation of the good work which is being done by the Rev. V. H. Moyle in this special direction.

#### USEFUL HINTS.

**SKETS LOADED WITH HONEY.**—In 'Echoes' of 15th August Mr. Walton justly suggests that how to deal with skeps loaded with honey, but with few bees, the queen having been crowded out, will be a problem which will trouble many bee-keepers. Here is a hint. Cut out the three centre combs by the use of a knife such as illustrated on p. 307. Extract the honey, or drain it out if not possessed of an extractor. Replace the combs as nearly in their former position as possible, and support them with slices of card pushed between them, leaving the skep upside down for twenty-four hours for the bees to relify them. Then feed slowly with thin syrup to promote breeding. The bees may be driven out for the operation, or by spraying the edges of the combs with syrup they will be attracted up out of the way of the knife.

**A USE FOR HONEY** (Blue-Ribbon men, please don't read).—Whisky and water, hot or cold, sweetened with honey instead of sugar, is rather too seductive for general consumption, but at the same time not bad.

#### BEE-KEEPING GOSSIP.

'Mel' sapit omnia.

The *Times* is still diffusing an interest in bee-keeping. The Hon. A. F. G. Leveson-Gower has confessed he has been 'standing on the bank' for ten years and let the stream roll by him. If he had only been cut off from bee-keepers and bee-literature for as many months, his information and knowledge too would be considered obsolete by advanced bee-keepers now-a-days. 1884 will ever be memorable not only for its harvest of honey, but for its harvest of apicultural knowledge also.

Surrey and West Kent are not the only places where the 'burn-in-alive' system is practised, and great prejudice exists against modern bee-keeping by a great many, but we have organized a system that must effectually stamp it out, and that soon, in our County Associations. I may venture to answer for West Kent that they will not long suffer such a reproach, and shall only be too pleased to hear Surrey wakes up from what now appears to be a state of lethargy, and teach her cottagers something more profitable and humane.

We have a good champion both for the Central and County Associations in the Rev. F. G. Jenyns. He knows how both are worked, and, moreover, is a good, practical bee-keeper, and—I had not thought of that—comes from Herts, too. He tells us a piece of news that will make 'Hampshire Hog' give a most satisfactory grunt, and make him and 'Paddy' better friends than ever. Here it is.—The Rev. J. Lingon-Seger is going to the north of Ireland 'to give a few lectures on bee-keeping and advice about forming local associations,' at their request. Happy Ireland to choose such peaceful paths, and get the assistance of such an able man!

The Rev. H. C. Sturges also writes to the *Times*, and claims for himself some years' experience in bee-culture;

and what he says about large county shows and educating the cottager in his own garden is all very good and true, but he evidently is not aware of the principles on which the 'Bligh Competition' is worked, nor the very large amount of trouble that is taken to diffuse their knowledge amongst their poorer neighbours by county and district secretaries and local advisers, and, I may add, bee-keepers generally, or he certainly would not write as he does. Hear what he says, 'I hope scientific bee-keepers and hive-makers will not act selfishly in this matter,—well, as to hive-makers I will not say a word, there is sufficient competition amongst them to keep the price right, but I do claim that bee-keepers generally are one of the most unselfish set of people associated for a common object to be found anywhere. What about the time spent on committees, judging, examination boards, and, I may add, the more deep and subtle branches of the science that we have been hearing about at our late conferences? But he will have a better word to say of both bee-keepers and bee-keeping when the Gloucestershire Association gets into good working order, to which, we hope, he will contribute his valuable apicultural experience.'

Here is a very generous act that is worth copying. A friend of mine, who is manager of an Improved Labourers' Dwellings and Allotment Gardens Company at Highgate and a bee-keeper, sends me the following:—Mr. Ward, of Church House, Highgate, placed a hive of bees last year where they would be watched by several cottagers, to convince them all was done fair and above-board; and this year he has taken eighteen 2-lb. sections, twenty 1-lb. sections, and 30 lbs. run honey from stock hive—a total of about 80 lbs.; the section honey at 1s. 6d. per lb., and the run at 1s., would come to 5l. 11s., and at Highgate! within hearing of 'Big Paul.' Well now, Mr. Ward has given this stock over into the hands of my friend, who has selected the most likely of his eighty-four tenants, and placed it in his care, with the only stipulation that a swarm is to be taken from it next spring and given to another cottager on similar terms, with a view to the extension of the movement. This will delight the Baroness Burlett-Coutts, I am certain, and a more generous or practical way of encouraging bee-keeping amongst cottagers could not be conceived or carried out.

They have been having their Harvest Festival at Uffington this past week, and amongst the offerings placed in the church were some fine supers of honey by our successful and enterprising friend, Mr. Sells, whose apian not only has done well this season, but is also looking well. A grateful Cornishman has also sent a fine super to 'Ye Olde Englishe Fayre' now being held at Truro for the benefit of the funds of St. Paul's Church in that city.

So our Yankee friends have let us into the secret of how 'Puryvor' by appointment to Her Majesty' was obtained, and chuckles about it. All right, Cousin Jonathan, not too fast, my man. John Bull is already finding out the difference in flavour between your best refined Californian and his home-grown. And what we shall have to do is, take a 'wrinkle' from the canny Scot and set Mr. Helmer in the witness-box in some of our large towns. You are a long way in the wood yet!

Mr. Oswald Lewis seems to have had a very busy time in North Wales. He is young in the job, but has lots of energy and enthusiasm. Mr. Minor, at Shrewsbury, gave a most gloomy account of North Wales as a honey district, but Mr. Lewis did not find it so, but gives a report of it more applicable to a Paradise than a Sahara. The heaviest skeps ever found in the hands of cottagers working on the 'let-alone' principle were found in North Wales by—AMATEUR EXPER.

### BEE DISEASES IN RELATION TO APICULTURE AND GENERAL SCIENCE.—BACILLUS GAYTONI (?).

All diseases may be classed as either functional, organic, or contagious. The latter are now very widely admitted to consist of ailments which are brought about by the growth and rapid multiplication within the living frame of vegetable organisms, commonly spoken of as germs, for more particulars in reference to which I must refer to the first part of my paper at International Health Exhibition. These organisms (micro-organisms) may be passed from individual to individual, and hence the possibility of infection.

Let us suppose we had never seen bees, but that we are told respecting them, that they live in very numerous colonies, of which the members are always in the closest contact; that their usual system of communication is by actual touch; that they habitually pass the food from one stomach to another; that all the food they have has been carried either within or upon the bodies of their fellows; that their very home is formed of one of their secretions; and that their beds, cradles, and larders, are all interchangeable. And then our informant asks whether we imagine such creatures would be liable to contagious diseases or no. Should we not reply that all the circumstances seemed such as must favour the development of such disorders? We then turn to our bee-books and find that authorities—whatever that may mean—tell us that bees are barely subject to contagious diseases, that the only one of moment is foul brood, and that that only affects the larvae. Mr. Root, a 'cute man, and one that I personally very much respect, says in that valuable and usually very accurate book of his—'A B C'—'I am very glad indeed to be able to say that bees are less liable to be affected by disease than, perhaps, any other class of animated creation.' Has logic misled us, or has observation been defective or wanting? I am constrained to say that, undoubtedly, it is the latter, and that bees are possibly, indeed, probably, more subject to diseases of a contagious kind than any other insect, and that the common belief is not founded upon study and investigation, but, as is so often the case in apicultural matters, is only possible through the absence of both. At any rate, during the last two months, I have been able to make out no less than five, or, possibly six, distinct disorders arising from that number of specifically different germs, all of which will require prolonged attention if anything very definite is to be arrived at respecting them. In addition I suspect strongly that true dysentery will also turn out to be an infectious disorder, but since specimens fail me the question must remain, so far as I am concerned at least, till another season.

A considerable number of cases have occurred in which numerous bees, small, hairless, and glossy, have been dragged *volentes volentes* to the hive door and then and there ejected, while in other cases crowds of these abnormal bees have died immediately in front of their homes. The question has been referred many times to the pundits, 'What are these bees?' The reply has usually given the information that 'the bees are robbers, old fellows indeed who have so often been severely mauled in being turned out from the communities they were plundering, that all the hairs of their bodies had been pulled out.' Quite satisfactory is this if one knows nothing of the subject, but a little acquaintance with the form of the mouth and foot of the bee would show this reply to be most opposite to known facts. The hairs of bees are of four distinct kinds, but none of them are of such shape or size that they can be pulled off in an encounter. The foot has a most beautifully delicate pad centrally placed together with four very long and pliable feeling-hairs. On its sides are two double claws widely set and so contrived that they cannot nearly meet.

With such an instrument the grasping of hairs is impossible, as it is also by the jaws, for reasons upon which space forbids me to enter. But although the stereotyped reply is no longer tenable a new and sufficient explanation is beginning to appear.

Miss Gayton, so well known for her very successful bee-keeping, has, fortunately for our subject, shown herself to be a most accurate and careful observer. This lady has furnished me with a number of bees of the kind referred to together with her notes and observations running over a period of three years, and which at my strong request I understand she consents to allow to be published at some future time in the *Journal*. These bees I find in every case filled with a bacillus some-what smaller than *Bac. alvei* (the bacillus of foul-brood), and which from experiments made at South Kensington in the Biological Laboratory have been already proved to be quite specifically distinct. We must wait for next season before any very complete account of the matter can be given, but at present I will content myself by saying that in this as in two or three cases the loss of hair is due to defective nutrition, the same cause that makes the writer so sympathetic with those whose heads are poorly clothed. Some years ago, I discovered that if hairs of young bees are by accident broken, they are reproduced by growing from the ends as does an injured lobster's claw. I have some most interesting cases of partial reproduction of hairs of bees mounted for the microscope. All this would lead to the supposition that weakness and loss of vital energy would tend to premature baldness, if I may be allowed the use of such an expression. This bacillus, undoubtedly, produces this effect, and so again I claim the right of giving a name, and so suggest *Bacillus depilis*, or the bacillus of hairlessness, as a fitting one. Although, perhaps, *Bacillus Gaytoni* would be better remembered and only a well-deserved compliment. So I leave the Editor to take his choice in a footnote.

The bees are, undoubtedly, raised in the hive from which they are ejected; but having in some way taken the disorder (Miss Gayton thinks probably from the queen; I have, as yet, no ground for an opinion) they are driven out as a danger to the community, for the disease once contracted, there can be but little question that it may be spread from one to another. Very large numbers of bees sent me from different parts of England and Scotland having the same general peculiarities also contain what at present I conclude to be the same bacillus.

With regard to the other germs found, my knowledge is at present so slender that I must advance nothing beyond the discovery of an enormously large bacillus which takes what is called the zooglea form, two, or possibly three, very minute kinds of bacilli and a micrococci. The micrococci will most probably turn out to be a putrefactive kind accidentally present. The whole subject is of great interest, and will, no doubt, hereafter explain, or help to explain, some enigmas in connexion with apiculture which cannot be other than useful. *Bacillus depilis*, or *Gaytoni*, is a very mild offender beside *Bacillus alvei*, but it will be interesting to note whether it succumbs to the same treatment. The merest beginner will not be likely to suppose that we are here discussing robber-bees pure and simple, but merely the 'abnormal bees' or 'black robbers.'

That bees are not, or only very slightly, subject to functional or organic disease, is, no doubt, correct. Such disease would forbid increase, and so put a check to their own propagation. By natural and relentless weeding out of the sickly, the survival only of the fittest is secured. I have, however, traced a disorder which seems very rare, in which the liver-tubes degenerate into a thick yellow oil, of which an enormous quantity was collected in the body of one bee I lately examined.

I must hurry on as I have yet to take up the most important questions. 1st, Is foul brood produced by chilled brood? Most positively not. Chilled brood, however, furnishes a very favourable resting place for the foul-brood germ, and so one is practically often followed by the other. Chilled brood is most absolutely unlike foul brood when microscopically examined. Yet if chilled brood be found I should begin treating the stock with medicated syrup at once, as the smallest trace of infection would run riot amongst the dead and neglected larvae, and establish a diseased condition as a consequence.

2nd. How does *Bacillus alvei* get into a stock? I am now morally certain that very many bees of a colony may be diseased for several months with this bacillus, and yet foul brood may not be found. The bees do clear out solitary cases of infection in the grub often, so that the malady may not at all be suspected and yet exist. There is not one single old idea about this disease which is not incorrect, except that it is contagious. Time, I am convinced, will fully prove that the old bees almost invariably are the channels of infection.

3rd. Is bacillus the cause or result of the disease? Undoubtedly the cause. The reasons are numerous. Every attack is marked by their presence, whilst in specimens from healthy colonies bacilli never appear. The bacilli increase in number during life, and at death pass into the spore condition. The bacillus during its growth, like other micro-organisms, produces a definite chemical product. By example, *Bacterium lincolni* produces lactic acid, *i.e.*, it sours milk. *Bacterium subtilis* produces another decomposition in milk, forming butyric acid. Without these organisms neither can lactic nor butyric acid be evolved in the normal way. In the Biological Laboratory Mr. Watson Cheyne and myself placed exceedingly minute quantities of coffee-coloured matter from a diseased cell into tubes containing a mixture of meat-broth, gelatine, peptone, and salt, guarded carefully from every kind of germ in the manner known to those who have studied the question. The bacilli multiplied and formed a growth in which were hundreds of thousands of millions of individuals in a peculiar characteristic arrangement somewhat like an inverted tire-tire. The tiniest speck was then from this collection inserted into a second tube, and so on until now the seventh is reached. In every case the same characteristic growth appears, a growth never previously seen with any known germ; and upon examining the sixth tube, what is found? The meat juice, &c., has been converted into the definite chemical product (something Mr. J. M. Hooker, Junr., as an accomplished chemist, would possibly like to investigate) formed in and giving the characteristic odour to foul-broody hives. For if one of our most accomplished bee-keepers were blindfolded and asked to smell this tube, he would exclaim, "What an awful case of foul brood this must be! There's no mistaking it, but it is the very worst I was ever brought into contact with." Can any thing more be wanting? *Bacillus* produces 'foul brood,' and not 'foul brood' bacillus. Our last proof shall be duly reported upon. When twelve tubes have been grown by successive inoculation, the contents of the last will be diffused through water, and some of it blown by a spray producer over a card of healthy unsealed brood. I will not prophesy, although I foresee the result.

In the same manner *Bacillus alvei* has been cultivated in Japanese isinglass (*Agar-agar*), and here it quickly forms spores at 98° F., the temperature of human blood; and nothing has given me greater pleasure, in connexion with this inquiry, save the curing of the disease, than to watch in this cultivation the conversion of *bacilli* into spores and spores into *bacilli*.—the ocular and most absolute proof of the lines of explanation which I felt to be the only possible one from the outset in my investigation.—FRANK R. CHESHIRE, *Aconite House, Acton, W.*

## LETTERS ON BEE CULTURE.

To the Editor of 'THE TIMES.'

Sir,—Although my remarks on the subject of bee-culture, which you were good enough to insert on the 16th inst., were very much at fault, they have, at least, been of use in drawing out such interesting details of the working, both of the British Bee-keepers' Association and of the County Bee-keepers' Associations, as have been given by Mr. Henry Bligh and Mr. J. Lingen-Seager on the 21st and 22nd inst. My apology to them for any apparent insinuation against the working of these societies must be grounded on my previous statement—viz., that, owing to circumstances, I have been unable to watch the progress made in bee-culture in England since the time when I first became a member of the British Bee-keepers' Association, about ten years ago, to which time my remarks, perhaps, would better apply than to the present. Notwithstanding, however, that much has been done since that time, I am under the impression that there are parts of England (I more especially refer to my native county of Surrey, and parts of West Kent) in which the 'burn-em-alive' system is still in full force, and where great prejudices exist against any modern improvements, which are not easy to eradicate, although probably these parts of the country would not be slow in adopting improvements if the advantage to be gained thereby were clearly put before them by experienced apiculturists. I also hold to my opinion, more especially in the case of the inexperienced, that a good deal of time must be spent in operations connected with bees, though no doubt a good deal of time is wasted by overzeal. I do not altogether agree with Mr. Lingen-Seager that in this case the busy find time while the idle do not; but I have little doubt that the idle, or those even who take up bee-keeping as a pastime, worry their bees unnecessarily where the man who has less time would leave them alone, and that often the former succeed less well than the latter.

However this may be, it is certain that the time when attention is most required to be given cannot well be calculated on beforehand. If allowed to swarm naturally the bees will choose their own time; and although mid-day is, I believe, the time they affect most, yet even then they may pitch in some most inconvenient locality from which time and care are required to dislodge them; or, again, they may either go to a great distance before they alight at all, or they may, as sometimes happens, after having been carefully hived, leave the hive, sometimes more than once, to seek other quarters more agreeable to them. Again, if artificial swarming is undertaken, the searching for the queen among a hive of bees is, to a beginner, to say the least, somewhat confusing, and often needs considerable time and care. Sometimes the guiding of the comb on the bar-frames is a troublesome business, the comb often in hot weather detaching itself altogether, and requiring to be attached to the bars in some artificial manner until the bees shall have refixed it themselves. No doubt these difficulties are not so much felt by those who have gained experience, and the time required by them for these operations would be much shorter. The system of introducing bar-frame hives by means of bar-frame supers seems an excellent one, as by this means the old system is dropped by degrees, and the cottager will gradually be induced to adopt the new one without any shock to his prejudices. What Mr. Bligh says respecting cheap hives is, no doubt, perfectly true, and if the expense of thoroughly well-made bar-frame hives can be borne by introducing them by degrees into an apiary no doubt it is far better to do so, as cheap hives on improved principles may not only have the disadvantages mentioned, but are liable to allow insects to penetrate into the crevices, and, unless made of good wood, are apt to become worm-eaten and rotten. In criticising bee-shows, my remarks were made in ig-

norance of the system of local shows which have now been developed under excellent management, and which are the very thing needed to introduce rational bee-keeping to the labouring agriculturist, and to encourage him to bring it to perfection, and make it a means of adding to his income. I have already occupied too much space with a subject with which others are so much more competent to deal than I am, but it is one of great interest and importance; and it would be exceedingly useful if more details and statistics on this subject could be published with the view of disseminating the subject still wider, and drawing further attention to its importance to the labouring population.—I am, Sir, your obedient servant, ARTHUR F. G. LEVISON-GOWER, *Viscount*, Aug. 27.

To the Editor of 'THE TIMES.'

Sir,—All bee-keepers (and they are many) who have at heart the welfare of their poorer neighbours will thank you for the insertion of the Rev. J. Lingens Seager's excellent letter on the work of County Associations for the advancement of bee-keeping. He in no way exaggerates their importance or the good they are doing. I should, however, be glad if you will allow me to point out that all who are interested in the subject should not only give their support to their own County Associations, but also recognise the very important work of the Central or 'British' Association, of which the Baroness Burdett-Coutts is the President, and in which she takes a lively interest, often presiding, not only at the annual meetings, but also at the monthly deliberations of the committee. And I am the more anxious to do this as Mr. A. Levison-Gower, whose letter on the subject of bee-culture appeared in *The Times* of August 16th, seems to be in ignorance, not only of County Associations, but also of what is being done by the Central Association of which he signs himself a member, although I fail to find his name in any recent annual report.

The Central Association, formed in 1874, has made it its foremost object to encourage bee-culture as a means of bettering the condition of cottagers and the agricultural labouring classes, as well as the advocacy of humanity to that industrious labourer—the honey-bee. And by its direct, or indirect influence, nearly all the County Associations now in active operation owe their origin, and it is still carrying on with energy its efforts in the same direction (several associations are now in course of formation), endeavouring, where these local associations are formed, to unite them together in a compact body of as busy workers as the bees themselves, by affiliation with itself, an affiliation which is not a mere form, but which carries with it many solid advantages. Competent lecturers and professed experts with the Association's bee-tents are sent to all parts of the country in furtherance of these objects. It was only the other day, at its last monthly meeting, that an application was received from the North of Ireland for the Association to send over someone of experience to give a few lectures, and especially to help in the formation of local associations; and in response, Mr. Lingens Seager has been asked to undertake the mission. Such an application is especially gratifying, not only as recognition of the importance of the Central Association, which has already done much for Irish bee-keeping, but as testimony that Ireland is awaking to find fresh sources of profitable industry in peaceful paths. Once a quarter representatives of County Associations are invited to meet the Central Committee in deliberation, and able papers, doing much for the advancement of bee-keeping, have been read at these meetings, such, for instance, as 'Wintering Bees,' or 'The best way of instructing Cottagers,' or 'Honey as Food,' and in close connexion with this last it may be mentioned that at the Health Exhibition there is shown, under the management of the Central Committee, in lieu of their annual show, a very large and interesting collection of everything connected with bees and bee-

keeping; where also could be seen, until lately, amid much of the purest honey, and in contrast with it, a case of bottles of adulterated stuff, called 'honey,' which is too often palmed off upon a credulous public, and which, unless exposed in its true nature, must make the uninitiated consumer have a very bad opinion of the busy bee, even if the horrible mixture is not prejudicial to health. At a Conference of Bee-keepers, held the other day at the Health Exhibition, this important subject of honey adulteration, and the means of detecting it, was further elucidated by an admirable paper read by Mr. Otto Hehner, the eminent analyst.

Among many large and learned books on bee-keeping, the Central Association, in furtherance of its aims, has issued several cheap publications, such as *Modern Bee-keeping*, especially designed for cottagers, which has run through many editions, and is really the cottagers' handbook, although Mr. Levison-Gower seems to be in ignorance of its existence, or at least never mentions it. And although not officially connected with it, the Association has its organ in the press in the *Bee Journal*, published twice a month, edited by the Rev. H. R. Peel, who was for years the hon. secretary of the Association, and is still the life and soul of the English bee-keeping world. Allow me further to point out that, as it is essential that the men employed by the County Associations as experts to visit and instruct the members at their homes should be competent men, there is a system now at work by which examinations in the science and practice of bee-keeping are held by the Central Committee from time to time, and certificates of these classes given to those who pass. Another subject now engages the attention of the Central Committee, which it will be well to ventilate, as it may have most important results. Some encouragement has already been received from the Educational Department towards the introduction of bee-keeping as a 'specific' subject of instruction in elementary schools—a matter in which Germany is far ahead of us. And it is hoped that the time is not far distant when yet further sanction will be given, and the subject will be allowed to be taught as a 'class subject' of elementary science, and children will learn not a smattering of 'science' generally, but one small branch of it thoroughly—a branch which, while it can be made strictly educational, can also be turned to practical account, and be the means of giving the poor an intelligent and profitable industry, and help somewhat to the bettering of their condition. Mr. Mandella, in a letter to the Baroness Burdett-Coutts, has promised to take the subject into careful consideration. Other matters of interest to which the Central Committee give great attention are the 'Economic Apiaries Competition,' by which has been demonstrated that bees can be kept, and made to pay well. Also the difficult question of the establishment of a honey market in London, where bee-keepers may get ready sale and a fair price for their honey. While, therefore, the County Associations are bringing the details of practical bee-keeping home to the cottagers, the Central Association, working at headquarters, is in a great measure the mainspring of the whole system, and is indispensable to its efficient working, even if there were local associations in every county, which it is hoped will soon be the case.—I am, yours faithfully, F. G. LEVISON, Member of the Committee of the British Bee-keepers' Association, *Karlshorst Rectory, Steingate*.

To the Editor of 'THE TIMES.'

Sir,—My attention has been called to the letter of Mr. Arthur Levison-Gower as inserted in the *Times* of the 16th ult., and also to that of the 2nd inst. Your correspondent is in no wise entitled to sign himself a member of the British Bee-keepers' Association, he having only been connected with that Society for the year 1875. True his name appears among the list of

members for the year 1876, but the Association's books do not show that his subscription was paid for that year. Mr. Leveson-Gower has evidently been dozing on the banks while the stream of advanced bee-keeping has flowed rapidly at his feet. My experience teaches me (and it is somewhat a wide one) that Mr. Leveson-Gower errs considerably in stating that a good deal of time is required by a cottager in the management of bees. As an example, I may mention a cottager, a near neighbour of mine, commenced bee-keeping about three years ago. At the commencement of the present season he had four stocks which had cost him something like three shillings for food to sustain the bees during the preceding winter. Two of these stocks gave swarms, making a total of six. From these six stocks of bees upwards of 300 lbs. of good super honey has been taken, and each stock is left with ample stores to support them during the ensuing winter months. This cottager is also a busy man in his garden, and takes numerous prizes for flowers, vegetables, &c., at the local Cottage Garden Shows. His hours of labour are from 6 a.m. to 5.30 p.m. I could quote numerous other instances of similar success, all of which have been attained through the dissemination of the knowledge of the improved methods of bee-keeping by the British Bee-keepers' Association, and the numerous County Associations which are affiliated to that Society. I venture to hope that Mr. Arthur Leveson-Gower will (with such facts before him as have been given by your correspondents, the Rev. J. Lingens-Seager, the Rev. H. Bligh, and the Rev. F. G. Jenyns) again renew his membership with the British Bee-keepers' Association. I am, your obedient servant, J. HUCKLE, Secretary British Bee-keepers' Association, Kings Langley, Herts.

#### MR. OTTO HEHNER'S PAPER ON THE ADULTERATION OF HONEY.

(Read at the International Conference held at the Health Exhibition on July 26.)

The Chairman announced that the subject of the paper to-day was the Adulteration of Honey, and he need scarcely say it was hardly less important than that which they had discussed yesterday. He had then read part of a letter from Mr. Cowan, and in the second portion, which he had reserved for this occasion, the gentleman said, 'The adulteration of honey is also an important subject, and I hope Mr. Hehner will show that the materials left in glucose during its manufacture are such as to be injurious to health. I can understand glucose prepared in a laboratory being pure, but that manufactured commercially is never pure and contains an excess of lime or sulphuric acid.' Mr. Cowan then went on to say, 'I hope something may be done to replace the adulterated specimens at the Exhibition, so that the public may know how to recognise the good from the false.' He must say that the Council of the International Health Exhibition, though it had invited them to discuss the subject of adulteration of honey, had certainly not assisted them in bringing the actual fact that honey was adulterated before the public notice. They had had a case fitted up filled with specimens of honey which had been purchased in the open market and submitted to an analyst for testing; but that case had been removed by the Council of the International Health Exhibition, for some wise and inscrutable reason of their own, doubtless possibly thinking that those adulterations should be allowed to live in the order of nature for the same reason that such animalcules as the *Bacilli alvei* were allowed to exist in her economy. Mr. Cowan had alluded to the 'manufacture of glucose.' Of course he (the chairman) knew some time ago that glucose might be manufactured out of old rags, and he was in fact told that an extensive manufactory of the kind was in existence in the neighbourhood of London, but he was not aware until yesterday that glucose was also manufactured

out of old disused pawn-tickets. In former days they were told that there was some process of renewal of the skin constantly going on, and that it was supposed to be entirely renewed in every seven years, so that during that period people might possibly eat their bakers; but it seemed to him that a new sort of cannibalism was now introduced, and that in consuming this glucose, in addition to eating their bakers in seven years, they might also eat their 'uncle.' However, the Conference would have the effect of bringing before the public the fact that honey was adulterated, and that the only safeguard they had against consuming adulterated honey, which might very possibly be injurious to health, was the efforts that were being made by an association like that of the British Bee-keepers in that direction, the result of which would give a guarantee that the substance sold as honey was pure. Without further preface, he would ask Dr. Hehner to read his lecture.

Mr. O. Hehner, having read his paper (see p. 263), the following discussion took place.

Mr. Cheshire thought they would all agree that the British Bee-keepers' Association ought to be very much congratulated on the fact that they had helping them in their work so able a gentleman as Mr. Otto Hehner. The ability of the paper had been apparent throughout, and another striking point in it was its eloquence and the accuracy of its English. Mr. Hehner occupied a very high position indeed in the chemical world, and they ought to listen with very great deference to everything he had to say to them. A very valuable book had lately been published on the subject of food adulteration, and if it did not actually bear Mr. Hehner's name it derived a great part of its value from his connexion with it. This question was one which touched them very closely indeed, because British apiculture would be very heavily handicapped if it had to contend against foreign adulteration. They would have quite enough to do to contend against pure foreign honey. None of them could probably object to good honey being sent over to England from the Continent or America at a lower price even than English bee-keepers could sell it, because it would be helping, of course, towards the desirable end of introducing cheap food into the country. But when it was found that the foreign producers were sending us what was actually corn-syrup, while they were giving us to understand that they were supplying pure honey of a very good brand, British bee-keepers had reason to feel sore on the point, and therefore everything they had heard on the subject from Mr. Hehner was very welcome indeed. The man who would label his pot 'refined honey' when he knew it contained something which was not honey at all stood in a great measure by the side of the man who would sell the public some kind of oleo-margarine and call it refined butter. When the public were buying those things they might imagine they were buying some very special description of butter—something of very fine quality indeed; and they would be making the same kind of mistake in buying 'refined honey.' Mr. Hehner had shown them the advantage of the use of the microscope in connexion with his investigations, and he had brought before them one notable fact as the result of them. He had stated that he had found some bees were more cleanly than others in the way in which they stored the honey in their hives, as he had ascertained that honey from some stocks was very much more contaminated with pollen granules than others. No doubt there were very great varieties amongst the different stocks of the same apiary; they had different habits and odd peculiarities running sometimes in directions against and sometimes in favour of producers and consumers of honey. There was one point which they should all think well out and try to act upon in managing their apiaries. In their endeavours to produce honey they were met with one difficulty in

the propensity of the bees to swarm, and he thought that under their present system of management they were constantly increasing that propensity. When a hive swarmed it was furnished with queen-cells, and the mere fact that the bees had swarmed was *prima facie* evidence that the queen had a swarming disposition. These surplus cells would often be used for requeening stocks that had not swarmed naturally, and so the swarming tendency would be introduced when it had not previously existed in sufficient amount to cause a division of the colony; for the progeny would inherit the peculiarity of the queen, and therefore they would be likely to get from such hives bees which would swarm, whereas hives which had not that propensity, and which were giving the largest amount of honey possible, were hives from which they did not raise their queens, and from which, therefore, they would not get bees with that habit of swarming. Bee-keepers, therefore, should notice the hives which had the strongest propensity for storing honey and not for swarming. Naturally they would then be always raising queens from the swarming hives, and be thus by selection tending to increase the swarming propensity, whereas, philosophically, the very opposite course ought to be taken. If they could only get bee-keepers to look this matter well in the face, and strive by careful examination of their hives to raise in their apiaries bees with a less propensity to swarm and a greater disposition to store honey, they would get a larger number of storing hives in a very few years hence. By the aid of the microscope, Mr. Hehner said they could detect the sources from which bees obtained honey. He had recently discovered that, supposing a person well conversant with the microscope, and knowing exactly where to look, were provided with a piece of comb at this time of the year, with, say, twenty cells, part of the foundation which had been put into the hive in the spring where there had been brooding and all the brood had hatched out, by the examination of that comb one could determine exactly the sources from which the whole of the honey in that hive had been obtained. It was very easy to understand when one once got an inkling of the manner in which it was to be done. He had discovered some facts with regard to the intestinal canal of the larva which had not been previously known, and he had found that in casting their skin the contents of the intestinal canal escaped with the cast skin and were then stuck on the inside of the cell. How could that occur? The fact was that the contents of the intestinal canal acted as a sort of glue, which capillarity spread out, and those contents and the skin were held all together against the sides of the cell and out of the way of the moving chrysalis. If they got that skin out, they would find between the cast skin and the cell walls all the cellulose forming the pollen envelopes, and then by putting them under the microscope they could pretty well determine the plants from which those pollen grains came, and so ascertain the sources from which the honey had been gathered. The paper they had heard read was so exhaustive and complete that it really seemed there was nothing left for anybody to say except to thank Mr. Hehner for it, and to congratulate the Bee-keepers' Association upon having secured the valuable aid of that gentleman.

Mr. Lyon said that after the scientific manner in which Mr. Cheshire had gone through Mr. Hehner's paper he had very few remarks to offer. One point, however, he would mention in regard to the direction in which they should proceed in this matter of the adulteration of honey. Mr. Hehner had informed them that the analysts had simply to analyse the samples given them by the inspectors, and the inspectors could not obtain those samples at least, so he understood Mr. Hehner to say, until they received orders from the town or local authorities. But he thought they could put the

whole train in motion in this way: that their local secretaries might worry the municipal authorities in their counties until they worried the inspectors, and the inspectors would in their turn worry the shop-keepers, and so samples of the adulterated honey would reach the county analysts. That, he thought, was a very good subject for the consideration of the county secretaries. In their own Bee Department at the Health Exhibition he had, not a fortnight ago, overheard a conversation between some ladies, who were suggesting that they should purchase some honey, and one of the ladies objected to buying English honey, preferring, as she said, to purchase Swiss honey. Why the public should like rubbish, as Mr. Hehner's paper had shown so much of the foreign honey really was, in preference to pure English honey, he did not know; it certainly showed a want of taste for the genuine production of the hive, and he therefore thought that every effort should be made to educate the public in some way in the matter, so that they should show a better taste in preferring our English honey.

Mr. Duman quite agreed with what Mr. Hehner had said as to the great difference in cleanliness among bees. He had noticed that the Cyprians were certainly cleaner than our English bees in producing honey. There was a marked difference in their honey, particularly in the comb. Mr. Hehner had stated that by putting grape-sugar with honey it was kept from crystallising; but after our honey was once warmed it would not crystallise again, and he should like to know from Mr. Hehner what chemical effect that had on the honey. Mr. Gladstone had told the farmers, some time ago, that they should take to producing jam, and Mr. Hehner had now suggested that they should take to the cultivation of honey in this country; but, as a farmer, he could say that it would never pay farmers to set up large bee-farms for the sake of the profit they could get from them. It was, no doubt, a very good thing to encourage cottagers to add in that way to their incomes, but when they talked of extending it to the creation of bee-farms on a large scale in this country, he could only say that he did not think it would ever pay the farmers.

The Chairman invited observations from Mr. Blow on the subject, as having the management of a very large bee-farm at the present time.

Mr. Blow thought Mr. Duman had taken rather a wrong view of the bee-farming question, because it would go very well with Mr. Gladstone's advice to which he had alluded. Mr. Gladstone had recommended English farmers to go in for raising fruit jam, and if they wanted a large crop of fruit they must have bees to fertilise the flowers. On the farm with which he was connected Lord Sudley had looked to a good return of fruit, rather than to a large crop of honey, but he had no doubt a good return of honey might also be looked for. That fact of bees acting as fertilisers to flowers should always be kept in mind by the English agriculturist. There was another point he would like to speak upon, and that was corn-syrup, to which Mr. Hehner had alluded, stating that it was impossible to produce corn-syrup perfectly free from traces of sulphuric acid. He would like to ask that gentleman whether it was not possible to produce on a commercial scale corn-syrup made with oxalic acid, the remaining traces of free oxalic acid being taken out with lime. Then with regard to the secretion of the honey, he would like to ask in what direction the honey-dew turned the ray of polarised light.

The Chairman inquired whether Mr. Blow could tell them how many farms were laid down in Gloucestershire.

Mr. Blow stated that about a year ago Lord Sudley asked him whether he thought it was advisable to add a bee farm to his fruit farm. Lord Sudley, about four years ago, had converted part of his heavy ground not suitable for other farming operations into a fruit farm of

100 to 200 acres, and it commenced immediately to give a return of strawberries and raspberries, and in addition to these fruits there were plum and other trees planted. That farm had increased in extent now to about 300 acres. He advised Lord Sudeley that it would be desirable to put down a bee farm in connexion with the fruit farm, even if it were only for the fertilisation of the flowers. Dr. Hooker corroborated his statement with regard to that, and Lord Sudeley decided to put down a bee farm. Between 270 and 300 stocks were now in existence; and as various other suitable places were being brought in, 100 more stocks would, he believed, be put down during the forthcoming autumn. At present he could not say much for the result, because the bees had been there scarcely six months, but a fair yield of honey had been obtained, taking all the circumstances into consideration.

Mr. Dorman had not spoken with regard to the usefulness of bees in fertilising flowers; he simply meant to point out that bee-farming on a large scale, for the sake of the profit that could be got from it, would never pay the farmer in this uncertain climate.

The Chairman was glad to see present Mr. Moyle, who was very much interested in the honey market which had been established at Reading, and requested him to give his views on the production of honey in this country and its adulteration.

The Rev. V. H. Moyle, after what had been said by Mr. Hehner and Mr. Cheshire, would not attempt to 'gild refined gold,' but would simply say that he had, in common with them all, derived a considerable amount of instruction from the lecture they had heard. He agreed with Mr. Hehner that they ought to do their utmost to increase the production and sale of genuine British honey. It was a painful fact that to a very large extent the taste of the British public at the present time preferred the foreign articles which were sold under the name of honey; and when they remembered that the British Bee-keepers' Association had now for some years pursued its course, and was now surrounded by so many children in its county associations, and had been encouraging bee-keepers throughout the length and breadth of the land, they should endeavour to do something to deal with the question what was to be done with all the stores of honey which were being raised throughout the country. People could not be everlastingly eating bread and honey; something should be done to find markets for it, and therefore he thought this was a subject which came within the scope of their operations, and every member of every association should do their utmost in their several spheres to promote a better taste and a desire for the consumption of true honey among the British public, and to see whether fresh channels could not be opened for utilising the honey produced by bee-keepers. As a member of the Berkshire Society, he might say that he had frequently been met with the question, What were the people to do with their honey, as they could not dispose of it? That led him to endeavour to open a market for honey. He had spoken to Messrs. Huntley and Palmer on the subject, who had kindly interested themselves in it, and had thrown an amount of energy into the matter which could hardly have been expected, and they had produced for the market some honey-drop biscuits. The meeting would be invited to pass judgment upon their quality by-and-by. He did not mean for a moment to suggest that anybody should buy up the honey at a cheap rate and sell it at a dear rate, and he did not want to interfere in the least with the market interests of any honey producers in this country, but he believed from the almost overwhelming mass of correspondence which was pouring in upon him every day that there were now very much larger stores of British honey in this country than there ever were before. He believed he could, if he wished, put

his hands on 150 tons of pure honey. In asking for supplies of honey, before venturing to do so, he first of all asked for a sample 4 oz. bottle. In some instances those samples had been sent to the local analysts, and they might now hope, in case of any difficulty, to refer to Mr. Hehner as to a supreme court of final appeal. He might also say that he was hoping to open up, with the assistance of a friend or two, a depot in London, one in Edinburgh, and one in Dublin. As he had already stated, he did not wish at all to trench upon the existing markets which any one had found for his or her honey. By all means let everybody sell their honey wherever and whenever they could get 1*l.* per hive for it—so much the better; but there were districts in this country where, to a great extent, cottagers were beginning to ask themselves whether it was of any use, after all, their throwing their energies into bee-keeping, and persevering with it at the risk of not being able to get a market for the sale of the honey which they raised. If, therefore, every member of the County Associations would do their best to influence local confectioners, or any manufacturers within whose province it might come to use honey in any shape or form, to set going the idea that British honey could be used more than it had hitherto been, which had been simply in the consumption of bread and honey, that would enable them to utilise the great stores of British honey which were now produced. He quite endorsed a remark which he had heard Mr. Baldwin make at Shrewsbury, that bee-keepers evinced disappointment because they could not get high prices for their honey; but perhaps it was sometimes their own fault, that they could not sell, by asking prices which were too high. In one case at the Exhibition the worthy owner of some exhibits had done nothing with them except pay their carriage up to London and home again. It would be far better for people to sell at the market price, whatever it was. They ought to see what they could do in the matter, and try whether the British public could not be induced to purchase pure honey, put in a plain and simple form before them, at a reasonable market price. If the matter was to be really taken up by the British public, it must be treated upon the general laws of supply and demand. On behalf of the honey depot already established at Reading, and the others which he hoped to establish at London, Edinburgh, and Dublin, he could say that they would do all they could to buy up the honey produced in their district, and so endeavour to do what they could towards keeping at home the thousands of pounds which were at present spent by the British public in foreign articles, and were in that way sent out of the country.

Mr. Cheshire said that as Mr. Hehner had suggested to them the propriety of labelling honey and indicating its principal source, it had occurred to him that that ability to, as it were, 'spot' the source of a piece of comb from an examination under the microscope might be made of great service, and in that way he would be very glad to be of use. He would endeavour to make out from any pieces of comb that might be sent to him what were the sources of the honey.

A Visitor would very much like to know what Mr. Moyle thought on the subject of price. A reasonable price had been referred to, and he would be glad to know what was considered a reasonable market-price for say 100 lbs. of honey.

The Rev. V. H. Moyle said the price he had been giving was 9*l.* per lb. for 100 lbs. parcels in 1 lb. sections, and paid the carriage.

The Rev. Lawson Sisson said he had purchased two samples in Norwich the other day, and a grocer in the town came up and asked him to sell the honey at so much per section, stating that he would give a guinea per score for the 1 lb. sections. He did not think, therefore, that he got a very low price for that honey according to Mr. Moyle's statement.



Mr. Blow was not aware whether all members present might have noticed that the honey which was placed on the market by foreign merchants was clear. The so-called 'Swiss' and 'Californian honey' he had seen was clear, and it was, he believed, owing to that fact that this honey obtained a ready sale. The British public apparently liked a clear honey, and that was just what the British bee-keepers did not produce. He had a number of customers who would not buy crystallised honey; they must have it clear, and in all cases where that was done, as with the foreign honey, it was readily sold. In fact British bee-keepers did not put up their honey in a form to command attention. Foreign honey was put up very nicely indeed, and it therefore attracted the public, but the way English honey was put up was not nice at all.

Mr. Bernard Dyer, as an analyst not being a bee-keeper, though he contemplated keeping bees on a small scale, entirely endorsed the appreciative remarks which had been made upon Mr. Helmer's paper. He had been well satisfied that nobody could truly appreciate a picture so well as an artist; the ordinary observer saw the effect produced by a picture, and might admire it for its excellence, but it was only an artist who could fully appreciate it as a work of art, because he could recognise its technicalities of painting and the labour involved in producing it before it saw the light. And so, no doubt, bee-keepers would be best able to intelligently appreciate the results arrived at in connexion with these subjects. But chemists, too, would very deeply appreciate the value of scientific labours by which Mr. Helmer had arrived at those results, and he was happy to say that he had been fortunate enough to have the opportunity of observing Mr. Helmer's progress in his researches in these subjects, not only with regard to honey, but with regard to bees-wax and other matters connected with the hive.

A Member suggested that it would be well if lists of prices could be published as a guide to both buyers and sellers of honey.

Mr. J. P. Sambels mentioned a sample of last year's honey which had been submitted to Mr. Helmer, and which had kept beautifully clear to the present time. Probably that gentleman would kindly give them the results, from a chemical point of view, of that sample of about 1 lb., which had been submitted to him in the clear, whereas other samples which had not been submitted to him had crystallised. The former had kept in beautiful condition down to the present, and would sell readily now. It had remained the same as before, and the flavour had not been in the least affected by the heat, though, no doubt, if honey were submitted to a very high temperature the flavour would be very considerably affected.

The Rev. George Raymond referred to the fact that the so-called 'Narbome honey,' obtained from chemists' shops, was usually purchased by nurses for invalids and children from an idea, probably, that being sold by respectable chemists it might be expected to be pure. He would like to hear Mr. Helmer's opinion with regard to the Narbome honey, which of course was supposed to be gathered by bees. One specimen, produced in the marshes of Lincolnshire, had been referred to by Mr. Helmer as having a special flavour, which he described. Honey gathered from bean-plants in the early part of the season was light in colour and very similar to clover-honey; but later in the season, when the bean-plants had become affected by attacks of blight, the honey brought in from them was very dark indeed. With regard to the question of pollen being carried into the hives by the bees to a greater extent in some cases than in others, and thus becoming mixed with the honey, he would make a suggestion whether that might not arise from the honey being taken, in the different cases, from different parts of the hive. They knew that the bees placed the pollen, and also a certain amount

of honey, near to the brood. In the feeding of the brood by the nurse-bees the pollen became mixed with the honey in the immediate neighbourhood of the brood-nest; whereas if the honey were taken from the outer sections of the same hive it would be precisely of the same description, but with out any admixture of pollen with it. He would therefore suggest whether it ought not to be noticed in any experiments which were made hereafter, from what part of the hive the honey was taken.

Captain Campbell, as Treasurer of the Surrey Bee-keepers' Association, thought he might say a few words which would help towards the elucidation of the question. He was one of the Committee which had procured the samples mentioned, and their opinion was most emphatically that they were obtained in the natural manner by the bees without any extraneous assistance, and they were taken from sectional supers in the tops of the hives. That would perhaps answer the question as to whether the honey had not been accidentally mixed up mechanically with the pollen in the hives. As to cottage-keepers being unable to find a market for their honey, he believed their great difficulty lay in their not being able to make it up for sale in a marketable form. When it was explained to them how that might be done by warming the honey, there was then another difficulty in preventing themselves from fairly boiling it, and turning it almost into a scald. So that he had found that his efforts to assist a cottager in that way had sometimes unhappily resulted in destroying the poor man's profit altogether. If it could be cleared by being warmed up to a certain temperature, he had never certainly gone up to as high as 120°, but he had warmed honey up to 90°, and had found that that temperature did not appear to destroy its aroma, unless it was subjected too long to the heat. If it was exposed to a high temperature for a long time it must have lost what it was so essential to have in good honey. In the *Journal* of the 15th of July, he had noticed a statement that there had been 1200 cins. of honey sent from Chili to Germany and England in about equal proportions; and a gentleman living near Guildford, a retired man of business and large bee-keeper, had remarked to him that it was impossible they could ever supersede foreign honey in the English market, for to the West Indies, for instance, they used to buy it by tons, and it was then put into boxes, shipped, and sold in the English market, so that the British bee-keepers would never be able to compete with that. But he thought Mr. Meyle had pointed out the right direction for obtaining a good market for their honey. A lady-keeper at Salisbury had mentioned to him that she had given up bee-keeping because she could not find a market for the honey; but very often he thought the difficulty lay in getting the honey clear. Among the hints given to bee-keepers in the *Journal*, it was stated that now was the time for bee-keepers to fill up their sections, and if they were for market, to feed up the bees with honey—'pure honey, of course,' but that if they were for exhibition and competition, that would not be permitted. He thought that was a very dangerous sentiment that they should get their best of pure English honey, which was to supersede that from all the rest of the world, by feeding the bees up with 'pure honey, of course,' and he thought that perhaps a good many people would not be particular, 'of course,' as to where they got their honey from. He had been, in one instance offered honey at 6d. per lb., because it was not put up in good form, and could not find a market; if he had given it to the supers, and had then sold it again at 1s. 6d. per lb., he might have been in that case an honest man, in a business point of view. But he would not say anything more about it, because he thought it would be much better not to suggest to people any means of getting their supers filled with artificial honey, because it seemed rather too like following the old adage, 'Catch your hare if you can, but if you cannot, steal it.'

The Chairman said, if Captain Campbell would quote chapter and verse from the *Bee Journal* for the matters he had referred to, no doubt he could be satisfied on the points he had mentioned. There was one point as to which a question had been put to him, upon which, however, his memory was not sufficiently good to afford an answer; but perhaps some gentleman present would kindly state what was exactly the value of honey imported into England from foreign countries generally during the last month from the returns given by Mr. Bellairs from Her Majesty's Customs.

Mr. Moyle informed the Conference that the returns showed there had been last month 30,000*l.* worth of foreign honey imported into this country.

The Chairman said that Captain Campbell had alluded to a lady in Salisbury who had been unable to find a market for her honey, and perhaps Mr. Burkitt, of the Wiltshire Association, might be able to say something which would encourage her.

The Rev. W. A. Burkitt was understood to say that he was not attending in a representative capacity, and was scarcely able to respond to the Chairman's invitation.

Mr. J. M. Hooker agreed with Captain Campbell that the advice given in the *British Bee Journal* as to feeding extracted honey was very dangerous. If honey could be bought for 6*l.* a pound and fed to bees, and the 1-lb. sections could be sold for 1*s.* 6*d.*, it would of course seem as if a large profit could be made; but as a practical bee-keeper he would undertake to say it would not pay to feed pure honey, as not one third of that fed at this season of the year would ever be put into the sections.

Mr. Otto Hehner, in reply, said he was in the fortunate position of not having to respond to any criticisms. He would first refer to the remark of the chairman as to the action of the Health Exhibition authorities. He had been furnished with samples of honey for analysis; they were afterwards put into a show-case, and he was told that those samples had attracted a good deal of attention. Of course the labels on the bottles bore the names of the gentlemen who sold them, and he could not himself see how any good could be effected by simply giving the public a number of undistinguishable samples of adulterated honey, and failing to show the public where not to go for them. In that case he might have made up the adulterated samples himself, but the samples were exhibited just as they were purchased. The removal of that case of samples with as much violence as if it had been dynamite, by a gentleman occupying a high official position in the Exhibition, with the assistance of two policemen, was, he thought, rather more than the occasion exactly required. However, if the Health Exhibition Committee did not think fit to bring the fact of the widely prevailing adulteration of honey before the public (and that case of specimens was the only exhibit in the building which claimed to show adulterated articles), he had, at any rate, done his duty by trying to draw the attention of the public to the matter. With regard to the action of local inspectors, of course the inspectors were directed by the town councils or other local authorities to collect samples. But the public themselves had a perfect right to collect samples and get them analysed. In fact, the Food and Drugs Adulteration Act was passed with that object. Still, of the 180,000 samples which had been analysed, hardly 1000 had been furnished by the public, because of the difficulties in the way. First of all, the exact letter of the Act of Parliament must be complied with, and it was not to be expected that every outsider should know exactly what he had to do; they had to formally divide the samples into three parts, seal them up, and then go to pay half a guinea to have them analysed; take the matter into Court; prosecute and get the man who had sold the article punished. Of course nobody would care to undergo all that trouble, and therefore

private persons could not be expected to prosecute tradesmen for adulteration, the remedy in their own hands being apparently so easy, because, of course, they could go away and deal with another tradesman, though very often the further they went the worse they fared. But if the Bee-keepers' Association could act in the matter, and bring sufficient pressure to bear upon the authorities, there would at once be a solution of the difficulty. Then as to the question why by warming honey it does not crystallise, he could only suggest the following explanation: Dextro-glucose was crystallisable, and by heating it was not destroyed, it was still there, but it was a remarkable fact, that very small quantities of albuminous substances prevented the dextro-glucose from crystallising. Such substances were contained in honey. The pollen granules, which were of a nitrogenous nature, on heating discharged their contents, and in that way furnished the albuminous substance which was inimical to crystallisation. That was the only way in which he could explain the fact that after being heated honey would not crystallise. It was quite true, as had been pointed out, that corn sugar need not be made with sulphuric acid, and that it might be made with oxalic acid. In fact he had pointed out that fact himself on a previous occasion, but he thought it was not wise to educate people to such an extent as to enable them to cheat the public. As a matter of fact it could be done, but as a matter of practice it was not done, at least at the present time. As to the properties of honey &c., he would be delighted to experiment with it if a sample were furnished him, say, an ounce or two ounces of it. If any gentleman would kindly send him some he would be glad to analyse it and give them the result. As to Narbonne honey, he had analysed some samples which he had found to be genuine. Then as to finding new channels for the sale of British honey he would venture to make a suggestion. It would be desirable to see the old-fashioned Saxon beverage mead brought up again to a somewhat higher repute than it had at present fallen to, and now that people were pretty generally aware that beer was not always made from pure malt and hops, there was a much better chance of that old-fashioned beverage being revived in public favour.

The Chairman, in proposing a hearty vote of thanks to Mr. Hehner for his admirable paper, said that Mr. Cowan, who was, he might say, the guiding light of their Association, had endeavoured while in Switzerland to obtain samples of pure honey at the *tables d'hôte*, but the proprietors told him that, while they were perfectly willing to provide pure honey, they were obliged to put adulterated stuff on their tables to suit the tastes of English tourists. That fact showed the necessity for educating the public taste in this matter. He would make one other remark with regard to the substitution of *oleo-margarine* for genuine butter. At Shrewsbury he had a conversation with Canon Bagot, who had interested himself so much in introducing good farming among the people in Ireland, and the Canon had told him he had found great difficulty in the matter, not only from the quality of the butters submitted for his opinion, but from the fact that the wholesale dealers were actually selling the stuff to retail dealers as pure butter, that the Adulteration Act was simply a dead letter, and that, until some amendment was made in its operation, he was hopeless of doing any good in the line which he had marked out for himself in Ireland.

Mr. Selater had great pleasure in seconding the vote of thanks to Mr. Hehner for the trouble he had taken in bringing the subject so ably before them. The first thing which British bee-keepers had to do was to stop, if possible, the sale of the adulterated honey which was at present put on the market, and also to pay special attention to the point of supply and demand, and to establish a means for bee-keepers to find out the actual

market price for the article they were prepared to sell. If producers of honey could offer it to buyers at its known commercial value, they would do a great deal to check the sale of adulterated honey, because, of course, if they put a price upon their honey which was not warranted by its commercial value in the market, they immediately gave a stimulus to the preparation and sale of the adulterated article. That point should not be lost sight of. In his own county, Buckinghamshire, complaints were made on all sides about the difficulty producers found in selling their honey, but he felt sure, if they made their prices dependent on supply and demand, much of the difficulty which they at present experienced would disappear.

The vote was put and carried unanimously.

Mr. Hehner, in returning thanks, said his aim in taking up the subject of the composition and nature of honey had been purely scientific. The ambition of the scientific man should always be to arrive at the truth, and he was most happy if he had been able to do anything to elicit it.

The Conference terminated with a vote of thanks to the Chairman.

## ASSOCIATIONS.

### STAFFORDSHIRE BEE-KEEPERS' ASSOCIATION.

The second annual show of the Staffordshire Beekeepers' Association was held on Wednesday and Thursday, August 27 and 28, in connection with the Staffordshire Agricultural Show at Stone. Since its institution the year before last, the County Beekeepers' Association, under the energetic superintendence of the honorary secretary, Mr. A. H. Heath, has done much in spreading a knowledge in this district of the humane and economic management of bees. The large display of honey, bees, and bee appliances, and the evident interest evinced by the numerous visitors in the various exhibits, showed unmistakably the good the local society is doing. Class I, for the best and most complete collection of hives and bee furniture, attracted entries from the principal firms in this line. Messrs. Abbott Brothers showed a most extensive collection. Amongst the collection we may notice the Combination hive, which has all the latest improvements. There were sectional supers of various kinds, and innumerable minor appliances for the easy and profitable management of bees. Their new cylinder honey extractor struck us as being very simple and effective, and works almost noiselessly. Messrs. Abbott Bros., whose hives and appliances the judge considered first-rate, took the first prize for general collection. Mr. E. C. Walton, Muskhum, Newark, obtained the 2nd award, and his collection was also a very good one. Mr. A. W. Rollins, of Stourbridge, who acted as the 'expert' of the County Association, also showed hives and bee-appliances, for which he obtained the 3rd award. For the three prizes offered for the best and most complete bar-frame hive there were four entries, Mr. A. W. Rollins taking 1st prize, Mr. S. B. Fox, Maer, 2nd; and Mr. J. Leake, jun., Beacon Street, Lichfield, 3rd. All these hives had their good points, and were cheap at 15s. In the similar class for cottagers who were not carpenters by trade, T. H. Dain, of Ashley, easily distanced the other competitors by his excellent workmanship (which would have done credit to a professional carpenter) and the neat appearance of his hive. Messrs. Abbott carried off the 1st prize offered for supers for harvesting honey in the comb in a salable form, and Mr. Rollins was 2nd.

There was a large show of both honey in the comb and

run or extracted honey, and in each class the competition was severe. In the class for six 2-lb. or twelve 1-lb. sections of comb honey, Mr. H. Wood, of Lichfield, was awarded first prize; Mr. F. Harper, Uttoxeter, 2nd; and Mr. J. C. Coleman, Stone, 3rd. There were sixteen entries, and many good samples were necessarily unnoticed. In the class for run honey, Mr. J. R. Critchlow deservedly won the 1st prize with sixty neatly made up glass jars of extremely clear, light-coloured honey, the 2nd award going to a much smaller lot of even a lighter shade. For the best exhibition of honey in any form made by bees belonging to an artisan or agricultural labourer in the county of Stafford, there were nine entries. Thomas Bond, of Shallowford, showed an excellent lot both in comb and run honey, and was awarded 1st prize. Amongst the unnoticed lots was a well-filled super, containing 47lbs. of honey shown by H. Withnall, Tatnill Lane, Burton, which probably would have taken a prize in a class for super honey exclusively. In observatory hives Mr. Rollins obtained the 1st prize, and Messrs. Abbott Bros. the 2nd. In the class for bees in straw skeps preference was given to those stocks which were the most likely from their strength to winter the best.

The programme of the bee show included the examination of candidates for third-class certificates of the British Bee-keepers' Association for proficiency displayed in the management of bees. There were six candidates, and the examiner, the Rev. F. S. Sclater, tested them in practical bee-keeping, including driving and the management of the bar-frame hive, supering, &c. The result of the examination has not been officially announced, but we understand that E. Clowes, Hole House Farm, Milton; Geo. Farrington, Burslem; and John Leake, jun., Beacon Street, Lichfield, acquitted themselves the best. On the first day of the show the candidates performed the operation of driving in the tent set apart for demonstrating, and on the second day it was occupied by Mr. Rollins, the 'expert,' who gave practical demonstrations in bee-management at intervals during the day.

Mr. A. H. Heath, the hon. secretary, the Rev. G. R. Bailey (Madeley), the assistant hon. secretary, aided by Messrs. Critchlow and Mellor, members of the committee, superintended the show, sparing no trouble in their endeavours to make it a success. Mr. Abbott, jun., also rendered valuable assistance in arranging the exhibits.

The Rev. F. S. Sclater, Drapmore Rectory, Madderfield was the judge.

The following is the prize list:

**HIVES AND BEE FURNITURE.** Collection of hives and Bee furniture—1st, 27, Abbott Bros., Earlsdon, Southall; 2nd, H. E. C. Walton, Muskhum, Newark; 3rd, 10s., A. W. Rollins, Stourbridge. Bar and frame-hive, with necessary appliances for winter and summer use, and for supering—1st, 15s., A. W. Rollins; 2nd, 10s., S. B. Fox, Maer, Newcastle; 3rd, 2s. 6d., J. Leake, jun., Beacon Street, Lichfield. Cheapest and neatest super for harvesting honey in the comb—Two equal 1s. 12s. 6d., Abbott Bros. and A. W. Rollins. Bar-frame hive, made by a cottager who is not a carpenter by trade—1st, 10s., T. H. Dain, Ashley, Market Drayton; 2nd, 5s., T. Bond, Shallowford, Stone.

**HONEY.**—Sections of comb honey in crate—1st, 15s. and silver medal of British Bee-keepers' Association, H. Wood, Paradiel Cottage, Lichfield; 2nd, 7s. 6d. and bronze medal of British Bee-keepers' Association, F. Harper, Balance Street, Uttoxeter; 3rd, 2s. 6d., J. C. Coleman, Stone. Run or extracted honey—1st, 15s., J. R. Critchlow, Maer Farm, Newcastle; 2nd, 7s. 6d., J. Harding, The Ashtons, Eccleshall; 3rd, 2s. 6d., J. C. Coleman. Honey in any form made by bees belonging to an artisan or agricultural labourer (prizes offered by Mr. A. H. Heath, Madeley Manor)—1st, 20s., Thomas Bond; 2nd, 10s., F. Bond, 52 High Street, Stone; 2s. 6d., T. Bailey, Whitmore.

**BEES.**—English or Ligurian bees in observatory hive—1st, 15s., A. W. Rollins; 2nd, 7s. 6d., Abbott Bros. Bees in

straw skep—1st, U., G. Caslunore, Stoke near Stone; 2nd, 10s., H. Wood, Lichfield; 3rd, 5s., J. R. Critchlow, Maer Farm.

A Committee Meeting was held at the North Stafford Hotel, Stoke on Trent, on Friday Sept. 6th. The Committee were honoured by the presence of the Rev. H. R. Peel, the late universally and deservedly esteemed Hon. Sec. of the British Bee-keepers' Association. Mr. Peel gave the Committee much valuable advice which cannot fail to bear fruit in the future working of the Association, and the members of the Committee feel greatly indebted to him for so kindly coming amongst them.

#### WARWICKSHIRE BEE-KEEPERS' ASSOCIATION.

On Sept. 2 and 3, at Stratford-on-Avon, the Warwickshire Bee-keepers' Association, under the secretaryship of Mr. James Noble Bower, held an exhibition of bees, honey, and bee-furniture, in connexion with the Agricultural Society's Show, and which was a grand success. The exhibits were displayed in a spacious tent, and were really imposing. Great credit is due to Mr. Bower for the completeness with which the arrangements were carried out, and to his exertions the brilliant success of the show is mainly due.

The quality of the honey exhibited was very good. With regard to sections, the competition was also keen. The exhibition of bee-appliances was very large, and included collections from Messrs. Baldwin, Abbott Bros., T. B. Thomson, and others. The Judges were, for honey, Messrs. Baldwin and Abbott; and for appliances, the Rev. E. Bartrum and Captain Deykin. In the manipulating-tent there were competitions, together with skilful manipulations, at intervals, and lectures delivered by Mr. Summerskill and other gentlemen. In the course of Tuesday afternoon the prizes were distributed, in the presence of a considerable number of interested people, by the Mayoress, Mrs. Hodgson, who was supported by Mr. Hodgson, C. M. G., and Lord Leigh.

The following is the list of prizes:—

**BEES.**—Stock of Ligurians, or other foreign bees: 1, John Walton; 2, S. J. Baldwin. Stock of English bees: 1, S. J. Baldwin; 2, W. Tyrer. Extra prizes given by the Warwickshire Agricultural Society for the best and strongest skep of bees: 1, J. Walton; 2, T. Booker.

**HIVES.**—Most complete hive on the movable comb principle: 1, T. B. Thomson; 2, Abbott Bros.; 3, W. E. Pengelly. Most complete hive on the movable-comb principle, for cottagers' use (price not to exceed 10s.): 1, J. Blake; 2, T. B. Thomson; 3, A. Joy. Frame-hive for general use—the work of an amateur or cottager: 1, J. C. Walton.

**STIVERS.**—Neatest and best rack, containing 1-lb. or 2-lb. sections: 1 and 2, Abbott Bros. Rack, containing 1-lb. or 2-lb. sections, suitable for cottagers: 1, C. G. Harrison; 2, T. B. Thomson.

**HONEY.**—Best exhibition of super honey from one apiary: 1, and silver medal, J. C. Walton; 2, W. S. Pridmore. Twenty four 2-lb. sections of comb-honey: 1, A. T. Adams; 2, J. Walton; 3, W. Bennett. Twenty-four 1-lb. sections of comb-honey: 1, J. Walton; 2, W. Bennett. Twelve 2-lb. sections of comb-honey: 1, Miss C. S. Hunt; 2, J. P. Starkey. Twelve 1-lb. sections of comb-honey: 1, W. S. Pridmore; 2, A. T. Adams; 3, J. Burman. Super of honey: 1, J. Walton; 2, W. Bennett. Best exhibition of run or extracted honey: 1, and bronze medal, W. S. Pridmore; 2, J. Blakham; 3, W. Tyrer.

**COTTAGERS' CLASS.**—Best exhibition of honey in the comb: 1, and certificate, T. Booker. Twelve 2-lb. sections of comb-honey: 1, B. P. Walton; 2 and 3, Rebecca Bennett. Twelve 1-lb. sections of comb-honey: 1, B. P. Walton; 2 and 3, Rebecca Bennett.

**MISCELLANEOUS.**—Best and largest collection of hives and bee-furniture: 1, Abbott Bros.; 2, J. S. Baldwin. Finest sample of pure bees' wax: 1, J. Walton; 2, W. Tyrer. Driving competition: 1, W. S. Pridmore; 2, J. Walton.

#### GLoucestershire BEE-KEEPERS' ASSOCIATION.

This Association held its first exhibition of hives, honey, and bees, at the Gloucester Agricultural Show at Stroud, on August 6th, 7th, and 8th. Messrs. Abbott Bros. and Mr. Hole were the most successful exhibitors of hives, &c. Mr. Marshall, jun., of Cheltenham, was awarded the silver medal for section honey given by the Central Association, and Mr. Burt, of Gloucester, received the bronze medal also for the 1-lb. sections. Rev. E. Bartrum, who kindly acted as Judge, examined Mr. Meadham, of the Herefordshire Association, for third-class certificate, and we are glad to say the candidate was successful.

Mr. Brown, of the Worcester Association, operated in the bee-driving tent. The G. B. K. A. have also had a bee-tent on the ground at Lotton, Stratton, and Winchcombe flower shows.

#### MONMOUTHSHIRE BEE-KEEPERS' ASSOCIATION.

We had, considering all things, a very satisfactory exhibition at Raglan Castle on August 25th. We took *3l. 0s. 6d.* at the tent. The success of the meeting was entirely due to the Rev. J. E. Sale, who has been most kind and useful in helping me, giving during the manipulations most interesting lectures with which the audience and spectators were much pleased. We were indebted to Mr. Compton Roberts, through whose liberality the tent was provided. Mr. Meadham, of Hereford, acted as manipulator, and gave great satisfaction. The prizes for the produce of the bees were by our committee confined to the County Association. I herewith send copy of our exhibits and prizes. The Rev. J. E. Sale acted as Judge.

**Class 1.**—Bee furniture. For 15s. hive: 1, M. Meadham, Hereford; 2, Levi Bevan, Govilon, Aberavenny; 3, Wm. Edmunds, Llanishen, Chepstow. **Class 2.**—For 10s. hive: 1, M. Meadham; 2, J. R. W. Hole, Tarrington, Hereford. **Class 3.**—Best hive by amateur: 1, Wm. Edmunds, Llanishen, Chepstow. **Class 4.**—1, Wm. Price, Aylton, Hereford. This was a straw hive, cane-bound, 16 x 9, very cheap and well adapted for the neighbourhood; super honey in sections could be extracted from it. **Class 5.**—For best exhibition of super honey from one apiary: 1, Mr. James Oakeley. **Class 6.**—For the best and largest exhibition of run honey: 1, Mr. James Oakeley; 2, Miss Arnold; 3, Miss Williams. **Class 7.**—For best super of honey in glass, wood, straw, or wood and straw combined: 1, Mrs. Dew. **Class 8.**—No entry. **Class 9.**—For the strongest and best skep of bees to be driven: 1, Mr. Joseph Price; 2, Miss Arnold; 3, Wm. Griffiths. **Class 10.**—For the largest and best collection of hives and bee furniture: 1, Mr. Hole.—JAMES OAKELEY, Hon. Sec.

#### HEREFORDSHIRE BEE-KEEPERS' ASSOCIATION HONEY-FAIR.

The first honey-fair (which will probably become an annual institution) was held in the Butter Market, Hereford, on Wednesday, Sept. 3rd, the market-day. The counters, ninety-four feet in length, were arranged in a hollow square, the salesmen being inside. A magnificent supply of honey was brought for sale; the total quantity being between one and a half and two tons, and the success of the fair was most complete, the counters being thronged with visitors and purchasers all day long. Sales were satisfactory, for although no wholesale purchasers were attracted, and the bulk was sold in single pounds, nearly 70% was taken.

The prizes offered by the Association brought forward an exceedingly close competition. In the class for largest quantity Mr. Thos. Charles (who took first prize for extracted honey at the Royal Show at Showbury) came first with a splendid exhibit of 924 pounds, chiefly of extracted honey, which had already yielded. The

Hon. Secretary came second with a good show in bottles and sections. The extracted honey was so fine in quality that the judges stated they wished they had been able to award prizes to some six of the entries. The sections were not so fine in quality, in fact, there seemed to be few really high-class ones this year; although a large quantity was sent. The cottagers' class was, as usual, poorly filled; the man taking first sent 140 pounds, and sold it all but a few pounds. Two cottagers (who, unfortunately, could ill afford the loss) had a quantity of honey smashed in bringing it by rail, it was packed in large trunks. It will be a lesson for them in future to pack in suitable crates, holding not more than twenty-four pounds.

Col. Pearson, Downton, Kingston, and Dr. Chapman, Burghill, Hereford, kindly undertook the heavy task of judging. The arrangements of the fair were made by the Hon. Sec. Mr. A. Watkins.

CLASS 1 (10 entries).—For the largest and best exhibit of honey, either in the comb, or extracted, or both: 1, Silver Medal of the B. B. K. A. and 20s., 921 lbs., Thos. Charles, Caerswall; 2, 15s., 455 lbs., Alfro Watkins; 3, 10s., 347 lbs., C. Jones, Lower Eaton. CLASS 2 (17 entries).—For the best twelve 1-lb. glass jars of extracted honey: 1, Bronze Medal of the B. B. K. A. and 15s., Rev. G. Herbert, Llanguren; 2, 10s., C. Jones; 3, 5s., W. Tomkins, Burghill. CLASS 3 (21 entries).—For the best twelve 1-lb., or six 2-lb., sections of comb honey: 1, Certificate of the B. B. K. A. and 15s., Thos. Charles; 2, 10s., Rev. G. Herbert; 3, 5s., C. Jones. CLASS 4 (1 entry).—For the best single super of honey (not being a sectional super): 1, 10s., Chas. Harrison, Kington, 32 lbs.; 2, 5s., Mrs. Danniell, Bullingham, 20 lbs. CLASS 5 (2 entries).—For the best exhibit of honey in any shape shown by a *bona fide* cottager: 1 (given by Mrs. Glim), a bar-frame hive with supers complete, value 10s., 61, W. Tomkins, 110 lbs.; 2 (given by Mr. W. Pilley), an Association flat-topped straw hive, with crate of supers complete, value 5s., 61, J. Sankey, 40 lbs.

#### WILTS BEE-KEEPERS' ASSOCIATION.

The following gained the Certificates of B. B. K. A., as experts of the third class at the County Show, August 13th: C. Warden, gardener to Lady Hervey Bathurst, Clarendon Park, Salisbury; W. S. Bainbridge, Esq., Mus. Bac., Marlboro' College; E. Day, bricklayer, Mildford Hill, Salisbury; Frank Bartley, gardener to General Rice, Codford, St. Peter. W. N. GIFFIN, *Editor*.

#### HANTS AND ISLE OF WIGHT BEE-KEEPERS' ASSOCIATION.

##### BEE AND HONEY EXHIBITION AT FARNBOROUGH HILL.

A very successful show of the above Association was held in connexion with the Horticultural Show in the beautiful grounds belonging to H. L. M., the Empress Eugénie at Farnborough Hill. There was a special tent set apart for the honey exhibits, and which was well filled with honey and appliances for modern bee-keeping. We consider, if possible, it is much the better plan to keep exhibits of this kind in a tent by themselves, as then only the visitors who feel interested are likely to remain long in the tent; and such are less likely to be scared by the presence of any stray bees, which are often attracted by the smell of the honey, and this gives exhibitors a better chance of disposing of their honey, &c. The tent should have a large label on the outside, and a larger one on the walls of the tent inside, so that visitors may see at a glance from the doorway that exhibits can be purchased. There was about half a ton of honey staged, including exhibits not for competition from H. L. M., the Empress Eugénie and Captain Elliott, J.P., Farnborough Park. The Honey and Bee Tents were under the management of Mr. W. T. Joyce, the Local Secretary for the district, assisted by M. Baigent, the local secretary for the Southampton district, and Mr. Daynport, who very ably acted as expert and lecturer in the Bee Tent;

the latter two gentlemen also acting as judges. The following is the list of awards:

HYVES.—Class 1.—For the largest and best collection of hives and appliances applicable to modern bee-keeping (notwo articles alike). First, E. M. Hart & Co., Stockbridge; 2nd, J. Hixon, Havant. Class 2.—For the best cottager's hive, price not to exceed 10s., 6d. First, E. M. Hart & Co.; 2nd, ditto.

HONEY.—Class 3.—For the best 12lbs. of super honey, in sections not exceeding 2lbs. each. First, W. Hunt, South Warnborough; 2nd, W. T. Joyce, Farnborough; 3rd, W. Brooker, Farnborough. Class 4.—For the best 12lbs. of extracted honey, in glass jars, not exceeding 2lbs. each. First, Hart & Co.; 2nd, W. Hunt; 3rd, W. T. Joyce. Class 5.—For the largest and best exhibit of honey in every form. First, W. Hunt; 2nd, W. T. Joyce; 3rd, Hart & Co.

EGGS.—Class 6.—For the best and strongest skep of bees. Ist, H. Lunn, Hawley; 2nd, W. Bartlett, Farnborough.—W. T. Joyce, *Hon. Local H. & I. W. B. K. A., Farnborough, Hants.*

#### HUNTS BEE-KEEPERS' ASSOCIATION.

The second annual show of the Hunts B. B. K. A. was held at St. Ives in connexion with the St. Ives Horticultural Society's Show, on Thursday, July 24th. The manipulations in the beehive were by Mr. T. B. Blow, of Welwyn, and in the evening, after his departure, an address was given by Mr. Howard, of Holme. The weather was very unfavourable, rain pouring down almost incessantly. A very good position was occupied by the tent containing the honey exhibits, which were more numerous and much superior to last year's. In addition to the hives and appliances brought by Mr. Blow to illustrate his lectures, Mr. Howard had a large and varied supply of hives and appliances. Mr. Howard also exhibited, not for competition, a large quantity of Sumner's sections, splendidly filled, which were greatly admired. The judge appointed by the B. B. K. A. was the Rev. F. G. Jenyns, and he was assisted by Mr. Blow.

The following were the awards:—

CLASS 1. Best specimen of Ington bees, exhibited with their queen in an observatory hive. Equal 1st, C. N. White, Somersham, and G. Reynolds, St. Neots. CLASS 2. Best super of honey, not sectional. 1st, G. Reynolds; 2nd, G. Ashmore. CLASS 3. Best 2 1/2 lb sections. 1st, C. N. White, Somersham; 2nd, J. Howard, Holme; Commended, C. N. White, Class 1. Best 12 2-lb sections. 1st, J. Linton, Esq.; 2nd, C. N. White. CLASS 5. Best 2 1/2 lb glass jars of honey. 1st, J. H. Howard, Holme; 2nd, A. Sharp, Huntingdon; 3rd, H. C. J. W. Allpin, S. Broughton. CLASS 6. Best sample of bees' wax, not less than 1 lbs. 1st, G. Reynolds, St. Neots; equal 2nd, E. Allen, Godmanchester, and Z. Hobbs, Little Stukeley. Cottagers only.— CLASS 7. Best 12 1/2 lb sections. 1st, G. Ashmore, Houghton Hill; 2nd, E. Bull, Brampton. CLASS 8. Best 24 or 12 2-lb glass jars of honey. 1st (10s., given by Rev. H. Matthews), E. Green, Holme; 2nd, E. Bull, Brampton; 3rd, Highly commended, C. Collett.

In addition to the above prizes, the silver medal was awarded to Mr. C. N. White, Somersham, for the best exhibit of sectional honey, the bronze medal was awarded to Mr. J. H. Howard, Holme, for the best exhibit of run honey, and the certificate was awarded to Mr. G. Ashmore, Houghton Hill, for the best exhibit of sectional honey in the cottagers' class.

#### HUNSTANWORTH (DORHAM) FLOWER SHOW.

This annual show was held on Saturday, September 6th, 1884. Prizes were offered for best specimen of honey in comb. The first and second prizes were awarded to Mr. William Pears, who exhibited twenty-four beautiful 1-lb. sections. This is the first time sections have been shown in this district.

#### BEE-TENT ENGAGEMENTS.

##### WILTS BEE-KEEPERS' ASSOCIATION.

Sept. 16. Cottage Garden Show, Chiseldon.

## Correspondence.

\*.\* All Correspondents forwarding Letters for insertion in the Journal, Reports of Associations, Shows, Meetings, Echoes from the Hives, Queries, &c., are requested to direct their communications to 'THE EDITOR of the "British Bee Journal," c/o Messrs. Strangeways & Sons, Tower Street, Upper St. Martin's Lane, W.C.'

### ROYAL AGRICULTURAL SOCIETY AND THE BRITISH BEE-KEEPERS' ASSOCIATION.

In reply to your letter I beg to state that the Council of the Royal Agricultural Society have always expressed themselves as perfectly satisfied with the manner in which their bee department has hitherto been managed by the British Bee-keepers' Association, and that they have never notified any desire to transfer the management of the bee department of the show to any other Society.—H. M. JENKINS, *Secretary*.

[With the above high testimony in favour of the management of the B. B. K. A. of the bee-shows held in connexion with the Royal Agricultural Society, we cannot help expressing our surprise at the presumption of Mr. Jackson in suggesting that the management of these shows should be transferred to the Association of the county in which they are held.]

### A HONEY COMPANY REQUIRED.

In the article in your last issue entitled 'A Honey Company Required,' I find the following passage:—'They (i.e. the bee-keepers of the Western Counties) appeared to have little hope that local depôts could be opened for the disposal of their honey, but a very general desire was expressed that the Central Association should make an onward movement and give assistance to the counties in the matter. And this desire is iterated and reiterated throughout the kingdom.' What onward movement can the Central Association make, or what assistance can it give to the counties in the matter, when the hands of the Committee are tied by the resolution moved at the last annual general meeting by Mr. J. P. Jackson, the Lancashire Reformer, which put a stop to the work of Mr. Duncan Stewart and the other members of the Honey Market Committee just when they might have been brought to a successful issue? May I suggest that a special general meeting should be called to rescind the obstructive resolution, and leave the Committee free to deal with the matter? If a Honey Company is to be formed it ought certainly to have the sanction and co-operation of the Central Body.—ONE WHO VOTED AGAINST THE RESOLUTION.

### MEMBERSHIP OF THE BRITISH BEE-KEEPERS' ASSOCIATION.

How can there be any doubt as to whether the Hon. A. F. G. Leveson-Gower is a member of the British Bee-keepers' Association or not? Rule vi. says, 'All subscriptions shall be payable in advance, and shall become due on the first day of January in each year, and until such subscription be paid no member shall be entitled to the privileges of Association. If any subscription remain in arrear twelve months, that is, until the 31st day of December following, the person not paying the same ceases to be a member.' The Hon. A. F. G. Leveson-Gower has not paid his subscription since the year 1875. How can there be any doubt as to whether he is a member? He is clearly not a member, and has no right to call himself one.—A READER OF THE 'TIMES.'

[The Hon. A. F. G. Leveson-Gower, in penning his

second letter to the *Times*, has evidently had a doubt whether he was justified in calling himself in his first letter 'a member of the B. B. K. A.,' as in the former he has omitted that appellation.]

### NOTTINGHAMSHIRE BEE-KEEPERS' ASSOCIATION.

Could you give me any information about the Nottinghamshire Bee-keepers' Association? I was at the first meeting when they formed it, and paid my subscription, but have not heard anything more about it, except that the Hon. Sec. (the Rev. A. H. Halley) has left the county. I hope it is not falling through, as I think it will be a great boon to the Notts bee-keepers. I keep looking very intently for the advertisement about the annual show and the bee-tent engagements for Notts in every issue of the *British Bee Journal*, but have seen none yet. I hope I may see one before long.—THOMAS ROSE, *Radcliffe-on-Trent, Nottinghamshire*.

[Perhaps the insertion of the above may elicit some information as to the present position of the Nottinghamshire B. K. A.]

### BEE-KEEPERS' CONFERENCES.

I beg to suggest that in my opinion it would do much good and increase interest in bees and bee-keeping were district secretaries in their several districts to endeavour to hold what I venture to call a Bee-keepers' Conference four times a year at some convenient place within their districts, where the business shall be to talk over the past, confer on the future, record facts and failures, and instruct as far as possible for the coming season. The times for such conferences must of course be left to the discretion of the secretaries of the several districts, but I think that the first week in November, to bring before the members the means to be taken for wintering, &c.; the third week in February, for preparations for the forthcoming season, weight and stimulating, feeding of stocks, &c.; first week of May, for supering, &c., and record of state during the winter; and third week of August for comparing of results, would be about the best times for the meetings; and if the secretaries try to make the meetings as interesting as possible, and include in them both subscribers and non-subscribers to their county societies, I think that such interest would be aroused as to set many a bee-keeper trying to arouse others in his village or town, and inducing them to keep bees upon the improved principles advocated by your *Journal*, and many a one to become better bee-keepers themselves. Added to this, if district secretaries would work with the county secretary, and try to get public meetings, and conversations, or lectures with discussions upon bees and bee-keeping in their several large towns, so as to interest the general public, many subscribers to the ranks of the county associations would be added and much interest created in the working of bees by our improved methods. Thus working men's clubs, mutual improvement societies, young men's and young women's Christian associations, mechanic's institutes, schools, and even mothers' meetings and sewing-classes, might be reached and interested; in as many cases as possible getting an influential gentleman to take the chair and speak at the meeting would ensure a good hearing and audience.

If you think these remarks worthy of a corner of your *Journal* you will much oblige your constant reader.—APIS.

### FOUL BROOD AND ITS CURE.

In 1882 I purchased a Carniolan queen-bee from a noted establishment. On its arrival I noticed a very peculiarly strong odour, which puzzled me, but I ascribed it to the different breed of bee. Subsequently I introduced a couple of stocks of bees to the hive into which the

queen had been introduced; but, behold my surprise! every bee was killed by these demons, which had by that time filled the hive; and the odour still with them caused me to conclude it was natural, the scent being so strong they resented all intruders. Of course I fully understood how to unite.

In the spring of 1883 I fed, and the Carniolan bred so quick I helped several of my weakest hives with Carniolan brood. Ready for the honey season I doubled one hive by taking brood from all the others, but it being a bad season the bees did little but breed. At the close of the season the bars were slung and returned to the different hives, to take to the beehive to gather more honey. I fetched them away late on, and discovered this strange smell in every hive, and on closely examining the cells found traces of what I considered foul brood. I got down Cowan's book for instructions, read all I could find in Root's, and concluded to use Cowan's recipe for salicylic acid; got a spray, and, after emptying the combs, I well sprayed them all over, opening every cell. It was a tedious, disagreeable task, but, as it appeared the only alternative, I did it with resolution. In the earliest spring I again sprayed, but could not detect any cells with indications of its presence, so removed the whole twelve stocks to a station three miles away for pasturage, in my opinion all well. I saw them occasionally, and as I had given a good allowance of food mixed with the acid, as per Cowan's recipe, I did not feed until the latter end of April; but when I began to feed I noticed in one or two hives a great diminution in numbers, and concluded it was for want of stimulating. So I fed them. Early in May I visited them, and found three stocks gone and another with the queen on the ground in front of the hive, with about a hundred bees with her and the hive empty. I removed the hives which had food in, but as I could not get these for several days I did not interfere with the others; when I did go, however, I found these more gone. I removed them, and examined the other three bar-frame hives. I had ten bar-frames and two skeps, which two I had bought for driving purposes—and found two much affected, so I took out the bees, put them into a skep, and treated them as directed. The other I was doubtful about, so left it standing, but found in June that it was going bad also. I put it into a skep three days, then joined to the other lot in the skep. I thought I had entirely destroyed it, but as your timely issue warned me, I had a search yesterday in one of my bar-frame hives, and find traces of it again. As soon as I possibly can I shall examine all, and have already sent for some of Cheshire's Phenol, and shall give it a trial.

This has been a lamentable year to me. I have struggled through five bad seasons, and just when the honey harvest comes my poor bees perish: ten (bar-frames) hives out of twelve. I purchased and determined I would keep six skeps in the future for swarms only, but if Mr. Cheshire's Phenol will defy its ravages I shall be encouraged to keep to the bar-frame. I have, however, with swarms purchased been able to hold my own at our local shows, and have taken eight first, six second prizes, one silver medal, two bronze, and one certificate. I have also tried to spread a knowledge of bee-keeping amongst railway men, as they have exceptional opportunities for keeping a hive or two of bees, and may be encouraged by seeing what can be done by a—STATION MASTER.

We shall be pleased to insert report of your experiments with phenol. [Ed.]

#### FOUL BROOD AND CARBOLIC ACID.

In an article on foul brood which appeared in the *Journal of Horticulture*, of date October 17, 1885, 'R. S.' [the Rev. Robert Saunders, of Sunderland, Dumfriesshire], says, 'From the bees in the hive having diminished

to less than half their numbers, and that, too, at a time when the queen was prolific, I strongly suspect that foul brood exercises a deleterious influence on the adult population.' That suspicion is now apparently converted into fact by the investigations of Mr. Cheshire.

There are also two articles, in the *Journal* referred to, by the said 'R. S.' (September 2, 1883, and September 29, 1879), on 'The Uses of Carbolic Acid' in the apiary, showing it to be a most useful auxiliary in all operations with bees, and stating that 'hives frequently subjected to its odour flourish amazingly, and I can well believe that it acts as a powerful agent in checking incipient disease.'

It thus appears we are indebted, not to any German or Italian, but to a countryman of our own for first bringing carbolic acid or phenol before the notice of bee-keepers. I understand 'R. S.' believes foul brood is frequently originated through bees getting access to honey or sugar in a fermented and sour state.—SUCUM CUCURBITURUM.

#### MR. JACKSON'S REPLY.

In recent numbers of the *B. B. K. A.* I have noticed various articles reflecting on the *Bee-keepers' Record*, on the Lancashire and Cheshire Bee-keepers' Association, and on myself. I also see that you have isolated some expressions from their context, and have 'challenged' me to explain them. There is little difficulty in doing so, but, first, let me put you right in some questions of fact.

The L. & C. B. K. A. was originally intended to be for Lancashire only and was formed at the express desire of the Rev. H. R. Peel; but when Lancashire and Cheshire Bee-keepers insisted on the two counties working unitedly at previous Lancashire Association having died an abortive death, the two-county association was definitely formed. There was not, nor is there now, a trace of the 'defiance' you speak of.

The 'North-Western Confederation' that you also tell of has never existed out of your own imagination. (To complete our demands I may add that the L. & C. B. K. A. has never either figured in a County Court suit, nor has it been 'within measurable distance' of one.) When we had existed twelve months or more, Mr. Huckle advised us, at our General Meeting, to divide into two associations, but he could give no good or even plausible reason for our doing so, and his motion was *unanimously* rejected. I believe I am correctly representing our members when I say that we fully recognise the position of the B. B. K. A., but we insist on a full measure of local self-government for ourselves, or, in other words, on the right to manage our own affairs. We also think the County Associations should be confederated together, and that they should be better represented at headquarters.

The 'attack' in the columns of the *Record* which you credit us with having made is nothing more or less than good-humoured, if forcibly worded, criticism, which aims at obtaining for the B. B. K. A. more of a representative and national character. As regards the 'mismanagement' of the B. B. K. A. shows, we stand to what we have written, but Mr. Huckle individually was never mentioned or even thought of in the matter. We pointed out in our article many ways in which past B. B. K. A. shows had not been made the most of; but the fact of a loss of nearly 200*l.* having been incurred on one year's exhibitions is of itself quite enough to support our statement. Still, the best answer we can give you is to refer to the present B. B. K. A. Exhibition at the 'Healthier.' There is an example of the mismanagement which any of your readers can inspect; the show is most decidedly not worthy of the B. B. K. A. The Bee Department has none of the educational value it might have had, and it is so unattractive as to be almost deserted. A wail of disappointment is set up by visitors, and they are glad to leave it to the solitude that usually reigns there. Is this the result of *good* or *bad* management?

As for 'self-election' of the Committee, no one can dispute the following facts. Each member of Committee must pay 20s. at least, and so have four votes. There are fifteen Committee-men, and thus they have but to vote for one another, and each of them has sixty votes over and above any outsider who may wish to enter the Committee. Thus, as our article stated, the Committee-men, 'no doubt unintentionally, but still practically, elect one another. What the *Record* asks for is, that no candidate shall be allowed to vote at the yearly election of the Committee.

To sum up the whole affair, the fact is, that it is yourself, Mr. Editor, who is endeavouring to stifle criticism, and who is trying to stir up strife by such epithets as 'schismatic,' 'false prophet,' 'defiance,' and so on. To prove this, we challenge you to insert the article on which your criticism was founded: it is not a long one, and it appeared in our issue of July 15th. If you do this your readers will see against what a hillock of (the *Record's*) criticism your fulminations have been directed.

In conclusion, I may say that the *Record* has no wish for a wordy warfare with the *British Bee Journal*. We have each our own circle of readers, and our own allotted places as promoters of bee-keeping, and we ourselves have only answered this 'challenge' of yours owing to your having so repeatedly uttered it.

(If you insert this reply at all please insert it in full, or we shall be compelled to publish it in our own paper.)—J. P. JACKSON, Editor *Bee-keepers' Record*; and late Hon. Sec. of the *Lanashire and Cheshire Bee-keepers' Association*.

#### A CORRECTION.

In the account of the meeting of County Secretaries at the Yeovil Show I am made to say that I had taken samples of honey to grocers at Weston-super-Mare and Clevedon. I do not know how this mistake has arisen, but I did not make any such remark. I said I knew a man living in my neighbourhood who intended to work the streets of Weston-super-Mare with a truck, having glass sides to protect his honey, and he expected to do a good business.—CHARLES G. ANDERSON, Hon. Sec. for Somerset.

#### BEES BREEDING IN HORIZONTAL COMBS.— REVERSIBLE FRAMES.

I regret that I attributed to Mr. Cheshire the authority of doubting the possibility of bees breeding in reversed combs, quoted by me on page 240, and must apologise for making the mistake. I find, by reference to the *Journal*, vol. ix., page 228, that it was the Rev. G. Raynor I ought to have alluded to, and these are the words he used: 'The cells were built with an upward pitch, and, consequently, inverting the frames would reverse the pitch. Now bees could scarcely use cells in such a position, either for brood or honey; and if they were compelled to cut them away down to the midrib, and build new ones, great loss of time would be involved.'

Will Mr. Cheshire say where I may find any publication from his pen the past sixteen years on this matter, as I cannot trace a sentence from him on the subject? I would have accepted his word, only he says I seem to fancy I have discovered something *unique*.

On reference to my letter on page 240, I distinctly give the credit of discovery to *some one else*; and I consider it unpardonable in Mr. Cheshire, with my letter before him, to impute such dishonourable conduct to me. He says, further, that he could have furnished me at least sixteen years since with comb the exact counterpart of that which I discovered. Let me tell him that neither the *part* nor the *counterpart* were in existence even three years ago, and that he has never seen them.—JOHN HEWITT, *Sheff'ld.*

#### WHY IS IT?

We may do well to ask why it is that some are trying to condemn Ligurian bees, when most of our prominent bee-keepers have decided in their favour. Probably there are many, especially among beginners who have been misled by the recent statements made in regard to the supposed uselessness of Italian bees. In the first place, all old bee-keepers will notice that those who have lately condemned them are mostly new hands, and such as have tried only one or two queens, and those for but a season or two. Some say they are 'all bees and no honey,' while Mr. Hewitt, contrary to the general rule, says that his one stock had to be assisted with brood from others; and later he again foolishly tries to pervert a statement made by myself, wherein I had said that whereas pure Italians were far preferable to pure blacks the latter possessed several valuable traits, and these traits could only be secured in a more prolific kind by breeding directly from black queens mating successively to yellow drones. Thus we can regain the beauty of the Cyprians, while retaining to a great extent the non-swarming propensity of the blacks and the better appearance of their comb-honey; the amiability of the Italians, the prolific qualities of the Cyprians, without their great drawback fertile-workers; and together with the judicious admixture of the three races, we shall have a most hardy and profitable strain of bees, as the results of such crossing have already convinced me.

Those who consider their black bees the best, will do well to notice if they really have any pure blacks at all, the probability is that they owe the superiority of their native bees to the fact that they have already been crossed with the race they blindly condemn, and hence, if only for the one purpose of infusing fresh blood, the bee-keeper dare not ignore the more prolific race.

Let me remind all those who in future intend to make their experience public, that it is not with one, not even with half-a-dozen queens of any given race kept for one or two years, that they can form a correct opinion of them as regards their honey-gathering capabilities. After a careful test of not less than three years, with at least six stocks, all practical bee-keepers will acknowledge that the more prolific bees not only gather, but store by far the larger amount of honey; while in the hands of the novice they often produce absolutely nothing in a poor year, and very little in a good one. We have not far to seek for the reason. There are many, very many I am afraid, who, finding a black stock queenless, and more often than not, miserably weak, think it a good opportunity to introduce a Ligurian queen. What is the result? If at the beginning of summer, and the black lot is not too far gone, this queen gives her bees all they can possibly do to attend to her brood; young bees begin to hatch out in due time, when she rapidly extends her brood-nest, and so keeps ahead of her bees through the whole season, until at last she has her hive full of bees, but little honey. At this time the Ligurian stock contains more bees than any other two, or perhaps three together in the same apiary. Who, then, can say these bees gather no honey, seeing that time after time these prolific queens raise up a grand colony from such a small beginning? The fact is, such stocks starting in poor condition, have during the season collected nearly as much honey as the best, though no surplus has been given. Under these conditions, of course, the first season has been lost, but here is a colony, which when supplied with sufficient food for winter, is in good order for the next season, and under fair treatment will give a heavy surplus. But no, the owner says, 'Here is a strong colony, I must divide that this autumn;' and when spring comes these are allowed to swarm pretty well as they like, and then a repetition of the former season occurs. The result is often the same the first year if a queen of either prolific race be given to an average black stock, unless she be introduced very early in spring.



When these imported queens are obtained, therefore, it is absolutely necessary that they be given to powerful colonies, as soon as they prove to be fertile, and then the proper balance of population over and above that required for attending the brood, will always be on hand ready to make the most of every opportunity.

Of all pure races, the Ligurian is undoubtedly the best, all points considered. Cyprians and Syrians, however, would be ahead of them were it not for one serious fault—they are so prone to start fertile workers, often by the side of a laying queen, and almost invariably if for any reason the hive be without a queen for a few days. For this reason I have decided to keep them simply for their droves to fertilize queens of other races, to obtain a special class of hybrids.

I am aware that much disappointment is caused by imported queens frequently dying off soon after introduction, or otherwise turning out badly, and more particularly is this the case with queens introduced late in the autumn; but this is no reason why the whole race is to be condemned; on the contrary, it simply shows the folly of those who attempted to judge all by the actions of one or two individuals. Imported queens are always placed at a disadvantage, and the only wonder is that as many do turn out well after all they have gone through.

It has been stated that Ligurians are vicious. Out of several hundreds I have had but one queen that produced vicious bees, but even these could be handled with impunity at the middle of a warm day when honey was coming in freely; and such is the case with hybrids, which are often inclined to sting, and if opportunity is given them, will certainly rob, but not to the extent some foolishly imagine, when they suppose that the large amount of honey obtained has been taken from other stocks. As regards the temper of the Benton queens now introduced by him, though conflicting accounts were at first given, those he now sends out generally produce bees more docile even than Ligurians. Probably Mr. Benton is doing his best to breed only from those queens which produce the most gentle bees, as this would account for the more favourable impression gaining ground in regard to them.

In conclusion, I would say that instead of being a great hindrance to profitable bee-culture, as some would have us believe, our industry would not stand where it does to-day, neither would the honey resources of America have been so fully developed, had it not been for the introduction of the Ligurian bee. Why is it then, that a few would condemn these and other prolific races, when an overwhelming majority of practical bee-keepers have decided in their favour? It is simply this, through gross mismanagement the former have failed to obtain the proper balance of population at the right time. S. SIMMONS.

#### HONEY PRODUCTS.

Thank you for your kindly notices in your valuable paper of the work in which I am interested, namely, procuring fresh outlets for the dispersion and consumption of pure British honey, either in its natural state or in some applied form.

I am thankful to be able to report increasing success; and, thanks to those who have acted on my suggestions, we can now say that pure British honey is used in

- Honey Drop Biscuits,
- " Lemonade,
- " No tar,
- " Medicines (various makers),
- " Cough Linetics,
- " Cattle Medicines,
- " Confectionery (various makers),
- " Juices,
- " Sweetmeats,
- " Creams,
- " Dentifrice,
- " Pomade, &c.

This is a stride forward, and I will leave no stone unturned to get it further established yet. One thing is being driven into my mind by experience; and it is this, that whilst we all strive as bee-keepers to prove to the public the value of honey in many ways, we must be content with smaller returns. One bar to the sale of British honey is its *high price*. If sold at a high price, it is a luxury for the wealthy; but surely, when we consider how little bees really cost an intelligent owner (less, I can safely say, than any other kind of live-stock), we shall secure larger sales if we buy and sell at lower rates. Apropos of this remark, *vide* a magazine I only learnt of a very short time since, the *Confectioner*, August, 1884, No. 88, page 85, wherein, under the heading 'Higher Confectionery.—Honey for Confectionery,' Mr. H. G. Harris, the inventor of the new delicious cake, 'Angel's Food,' writes thus:—

'Adjoining our exhibit at the Health Exhibition is the very elaborate exhibit of the British Bee-keepers' Association, and a few days since, whilst looking at some specimens of the honey shown there, I had a short but interesting conversation with Rev. V. H. Moyle. He explained to me that his desire was to popularise British honey as opposed to foreign imports, often largely adulterated with sugar, glucose, and other matters. I pointed out to him that the surest way to make an article popular with the masses was to make it cheap as well as good; and that the sweet-eating public will not cut honey at 1s. per lb. from patriotism, when really good pure pure jam, too, can be bought at half the price. Patriotism is a splendid thing in its way, but it's "not negotiable" unless run upon commercial principles. At the same time there seems to be an opening for honey as a new factor in confectionery, and I purpose making some experiments very shortly as to some honey novelties in various forms, in addition to Lecerlet de Bale, which some time ago I made quite largely, and which found a very ready sale. I note that some few samples of Lecerlet are on show with the Bee-keepers' Association [Mr. Cowan's, V. H. M.]. They are very good indeed. The results of my experiments I will publish in some future issue.'

H. G. HUMPHREYS.

This is a long extract, Mr. Editor; but well said, Mr. Harris, say I; and if Mr. Harris will only make for us some such delicious honey confectionery from the honey I have sent to him, as the confectionery and *pocherché* 'Angel's Food,' he has made and sold, he will add yet another triumph to the progress in 1884 of honey in its applied forms.

At the approaching Fourth Annual Show of the Barks, B. K. A. at Reading, on October 1st and 2nd, we intend having a special feature never yet largely shown in this country, and that is, one department wherein honey in its applied forms may be seen and purchased in the articles enumerated at beginning of this letter.—V. H. MOYLE, *Brook House, Burghfield, Reading.*

#### CONDEMNED BEES, AND HOW TO MAKE THE BEST OF THEM.

On receiving the *B. B. J.* by last post on 30th August, I commenced to peruse it, but had not got very far when I was startled by the fireworks of 'Amateur Expert' fizzing about my ears. When I had recovered myself a bit, I found myself annihilated by Mr. Buller coming down upon me like a 'cartload' of bricks. I felt inclined to ask, with the American gentleman who played an unsuccessful game of cards with that Heathen Chinee, 'Do I sleep? Do I dream? Are there visions about?' Surely I must have dreamed that I bumped and brushed out nearly thirty stocks this time last year! I could not have done it, or, if I did, I must have made an awful mess of it. The combs must have broken in several places; the bees' nest, of necessity, have been smothered. Does not Mr. Buller say so? and have you not independent testimony to his ability to set every writer in the *Journal* right? And when I closed the entrances

(but without stopping the ventilation, Mr. B.), all the bees 'must, of necessity,' have been 'overpowered and stifled.' And those suffocated bees must have attacked me. There can be no mistake about it. 'Amateur Expert' tried it 'once,' and found it so. And yet (dreamer that I must be!) I have for twelve months been under the impression that I had brought home my bees and made stocks of them! Well, as I had to start early on Monday, the 1st of September, on the same errand, I must at once go and try to find among the lumber the driving-stand, and the skeps, and the skewers, and the canvas. It clearly won't do to act contrary to the superior wisdom of my critics.

3rd of September.—I have returned from my trip, and most humbly confess to the Hertfordshire authorities that I really have practised what I preached—smoking, closing, bumping, brushing, and all. My first lot to be taken was a single stock thirteen miles from home. From the time I got out of my trap until I had brushed out the bees, put them into my box (this I did as it was pouring with rain, and so all the bees were at home), delivered the combs to the owner, and got into my trap again, was ten minutes. Two miles to the next place; six lots; still raining heavily; time, including everything, forty minutes. Next lot five stocks; time, forty-five minutes. From here to next stop, three miles. Here I drove two lots, which had sticks in which I could not draw. These two lots took me, including getting out the tackle and re-packing in the trap, an hour and a half. Others I drove took me as long. Did I get any bees drowned in honey? Yes, I did; one lot which I drove for a man who had seen driving at a show and wanted to see it again. I had only a swarm to operate upon, and the combs, being heavy and tender, broke down; so that before the bees were out the crown of the skep was half an inch deep in honey. They had to be brushed off the combs after all. At one place, where I expected to get some, I found the owner, a plate-layer (not the *Platlayer* of the *B. B. J.*), had himself brushed out his bees. He was a bit puzzled what to do with them, and I helped him to unite with a cast. He had seen me drive for him for four years, and last year he saw my bumping and brushing process. He always said driving took too long; he could not waste half an hour when a brimstone match would do the job in five minutes. But of the other plan he said, 'Why, it don't take longer than puttin' 'em down.' So, you see, Mr. 'Amateur Expert,' that, after failing for four years to teach him the 'more excellent way' of driving, he soon learnt the 'most excellent way' of brushing out.

I think I can account for 'Amateur Expert's' failure. He very likely made a ball of the grass, and hermetically sealed the entrance. I push the blades in lengthways, so that air can enter, but not the bees. It is not the foragers, Mr. Buller, which annoy; it is when they have gone in and told the others that there is honey to be had for fetching, and asked them to come and help them, that the annoyance commences.

I did not have one lot smothered, nor one comb which did not break out just where I wanted it—close to the crown. Of course, according to the authorities, they ought to have broken out two inches down, and got smashed up into small pieces. But somehow they refused to do it. How strange, that practice sometimes will not accord with theory, even when propounded by Mr. Buller!

It is a pity that these gentlemen could not agree on all points. One says bees, when confined, rush to the cells and gorge. The other says the suffocated bees, not being gorged, attacked him. Who shall decide when such learned doctors disagree, and only agree to disagree with my communication of my experience (not my theory) for the benefit of my brother bee-keepers? My name should have been appended to the article. I am prepared to maintain the truth of it, and now subscribe myself your obedient servant,—F. LYON.

Dr. Wallace, Parsonstown, writes, 25th August:—'I have carefully read your paper on "Condemned Bees," and made my first essay at bee-manipulation last Friday. I never had anything to do with bees before, so I tried on one hive only. I succeeded far beyond my expectation, got no stings, and have the swarm safe in my bar-frame hive.'

Mr. A. Robinson, Hexthorpe, Doncaster, writes:—'For the last two Saturdays I have adopted the system of breaking the combs by bumping the hives when taking condemned bees, and find it answers admirably.'

#### HONEY GRANULATING.

On visiting the Bee Department of the Health Exhibition yesterday, a fly-leaf headed, 'British Beekeepers' Association—Important Notice,' was given me by the superintendent. The notice begins, 'All honey, if pure, will granulate or become candied as soon as cold weather sets in. . . . and that which will not granulate when exposed to cold is invariably adulterated.'

Now what I want to point out is the position in which the B. B. K. A. puts itself and some of its members (myself for instance) by the use of the word 'invariably.' On turning to Ogilvie's *Imperial Dictionary*, under the word 'invariably,' I find the following meanings given, 'Not variable; constant in the same state; always uniform; immutable; unalterable; unchangeable.' Now I contend that by the use of the word 'invariably' all liquid is condemned as adulterated.

My practice is, suiting the tastes of my customers, —for I find where one will buy granulated honey six will buy clear—directly my honey is extracted, it is put in 5 lb. jars and stood upon the hot-water tank that supplies my house. There it remains, covered only enough to keep out dust, from ten days to three weeks, according to the original consistence of the honey; in that period it is generally twice skimmed, and I get a splendidly clear article, which may have lost a little of the original floral aroma, but which will keep clear and unalterable for years. This I label 'Pure Kent Honey,' and my peculiar brand is put on it.

Now if I might suggest a substitute for the word 'invariably,' I would counsel 'generally.' Turning to the same source for its meaning, we get, 'In general; commonly; extensively, though not universally; most frequently, though not universally;' thus expressing what I think is more nearly the meaning of the B. B. K. A. in issuing the leaflet.

If not mixing subjects too much, I should like to know what alteration honey undergoes chemically and as regards its food value, after being treated as I treat mine; and if Mr. Behner, through the medium of your *Journal*, would tell us, I should be happy to help him in any way by sending samples.—JOHN MARTEX, *Dunkirk, Faversham, Sept. 4th, 1884.*

#### DRY SUGAR-FEEDING.

I wish to join Mr. Howard in thanks to Mr. Simmins for his sugar-feeding dummy. I have tried it in all my nucleus hives this summer with success; I am now using it in all my hives to keep the queens breeding; for stimulative feeding after the honey harvest and in the spring I consider it all one could desire. Some of its advantages are, it saves time (no small matter with many bee-keepers), if the dummy is properly made it will hold a week's supply for a strong stock, no boiling of syrup, no spilling of food, which often starts robbing; in spring when the temperature varies very much syrup-feeding is a nuisance; when the weather is favourable the bees will take the syrup, if a frost sets in it is not touched; if the syrup is left on and the feeder not perfectly level

it will drip on to the bees. I have opened a hive after such a spell of cold and found the bees covered with sugar, through the syrup drying upon them, looking very much like hoar-frost, whereas the dry sugar may be left and if not touched for a month it takes no harm.—L. WREN, *Levestoft*.

[We have recently received several letters bearing testimony to the beneficial effects of dry-sugar-feeding. One writer says that its discovery by Mr. Simmins is only second to that of Mr. Cheshire in curing foul brood.]

#### WHAT SHALL WE DO WITH OUR HONEY?

From letters in the *Bee Journal*, it appears many are asking the above question and waiting for the answer. I think bee-keepers can help themselves to some extent if they will try. I should like to preface my remarks by saying that in this district there are now at least a hundred bar-frame hives where you would have found nothing but skep-les than three years back.

In the spring of last year a gentleman—not an apianian—put to me this important question: 'What is the use of advising so many to keep bees? what can they do with their honey?' I replied, after a little thought, 'Tell them to bring it to me, and I will buy it.' I then gave notice to all my customers that I was prepared to buy all the honey they could produce. In June I bought the first sections. I set out one window of my shop with honey and bee appliances. The novelty attracted attention, and in six months I retailed over the counter nearly 600 lbs., principally in 1-lb. and 2-lb. jars and sections; I could have sold more, but during August I could not get all I wanted. This year I expected to buy sufficient in the immediate locality with my own to meet the demand, but I have already purchased about 3 cwt. out of the district, and must buy more.

I shall be glad to give further information if it will help to a solution of the difficulty experienced by some in getting rid of their honey. L. WREN, *Levestoft*.

## Echoes from the Hives.

*Fairford.* Our bees have done very well, and we took off a fair amount in sections in June and July, but very few of them were filled out round the edges; but we were rather disappointed at the end of August, for, although the weather was very fine, there was very little honey stored in the supers. JOSEPH COOK.

*Newport, Salop.* I have a Ligurian stock which has swarmed four times this year, besides having ten Woodbury frames of brood taken from it. The stock was rather weak in the spring, but, by gentle feeding, the queen by the end of May filled a Woodbury hive with brood, which was taken from her on June 1st for the purpose of raising young queens. (The brood being placed in the place of a strong stock.) The queen and her bees were placed in a two-by-two Woodbury hive, filled with old comb, which they partly destroyed. The queen rapidly filled the hive with brood, and there have been four swarms from that hive, the last on Sunday, July 27th. The second and fourth swarms I sold. R. ASTON.

*Childerton Rectory, Salisbury.* I have just driven for a parishioner a flat-topped straw skep, in which a swarm was hived on the 26th of May last. The gross weight is seventy-seven pounds. EDWIN P. BARROW.

*North Leicestershire.* As there is no heather in this neighbourhood, the season closed for good on August 30th. As a matter of fact, the bees did very little collecting after July 9th. Driving and securing condemned bees is now the order of the day, and luckily so in some cases, for reports of queenlessness are more than usually rife. Robbers and wasps are still (September 8th) very troublesome.—E. B.

## NOTICES TO CORRESPONDENTS & INQUIRERS.

**IGNORO.**—1. *Robbing.*—As mentioned in our private communication, this is a clear case of robbing. Mr. Abbott's robber-preventer is an excellent one. It consists of a tube of perforated zinc attached to the entrance, out of which the bees can come through the tube, but the robbers try to find their way in at the base. Every now and again the bees are admitted, and the robbers soon get tired of trying to find their way in. 2. *Remedy for Stings.* Have you tried Dr. Pine's remedy for stings (advertised in our columns), which has been spoken highly of for many years?

**A BEGINNER.**—1. *Queens.*—The only one of the queens sent which is at all recognisable seems by her wings to be an old one, but both are so crushed as to be almost undistinguishable. 2. *Ekes.*—If the combs are not built down at all into the ekes, it would be as well to remove them; but no harm comes of a space below the bees, so if the combs are built down so that they would touch the floor, leave the ekes on.

**BOWNESS.** The bees forwarded were hybrids. No. 1 a hybrid which had lost its pubescence through disease, No. 2 a hybrid queen.

**S. N.** *Moving Bees.* Bees may be moved now by the process described in the reply to E. Z. SYNGE, but not later than a few days after you read this.

**J. M. D.** 1. *Condemned Bees.* There is no objection to putting more than three lots of condemned bees together, and the stock will, of course, be all the stronger. 2. *Feeding.* It is a very unusual thing for bees to refuse syrup. Are you sure that, from any defect in your method of putting on your bottle, they are not unable to get it; or did you burn the syrup or spoil it in any way? Try syrup made with refined crystallised sugar.

**G. C. ARLAND.** We should be obliged by being favoured with your full address.

**A BEGINNER, Elmville.** 1. *Queens.*—It is probable that after sending off the swarm the young queen was lost when out to meet the drone, and the queen-cells in this case are worthless—merely a despairing last effort. The bees have consequently dwindled, and will end in being robbed and destroyed. There is no remedy but to mix the few remaining to some other hive. 2. *Quits for Water.* Two thicknesses of flannel, with a piece of carpet over them. 3. *Side Spaces.* Side spaces may be filled with chaff, shavings, or cork-dust.

**T. MARRIOTT.** *Sufficiency of Food for Winter.*—If your three colonies have taken 140 lbs. of syrup of the strength you mention—12 lbs. sugar to 8 lbs. of water besides honey collected, there can be no doubt that they have filled their hives, and are in good condition for wintering. Having known the skeps from the floor-board, by passing a knife round under the edge, you may raise them carefully and examine them, or even gently turn them up, when you will have clear demonstration of their state. There will be no difficulty in examining the frame-hive. The quantity of honey stored will depend upon the fecundity of each separate queen, and you will find more brood and less honey in one than another. Continue feeding accordingly.

**W. C. BROWN.** *Extracting Syrup.* In extracting there is no danger of throwing out the syrup of last year's store. If a small quantity remained it would probably be in a state of granulation, and would in no way deteriorate your sample.

**J. S. B.**—1. *Wasps.* Wasps and robber bees will quickly destroy queenless or weak colonies which have not energy sufficient to defend themselves. Where hives are strong, populous, and have good queens at

their heads, neither wasps nor robbers will prevail against them. 2. *Feeding*.—Our experience with the 'Raynor' feeder is the opposite of your own. We have over a dozen in use at the present time, and there is no leakage. If correctly made leakage is impossible: charged with water, it has stood for days without a drop escaping. The dome, or stand, should be placed in position first, not leaning to either side, but in a horizontal position. The bottle should then be filled, and the metal top being screwed on tightly, it should be gently inverted, and placed upon the dome. A strong colony will take down from two to three quarts per day of thick syrup. 3. *Excitement of Bees*.—Your bees had discovered food at some distance, and were conveying it home, whether *honestly* or not we cannot say. The same thing has occurred in our own apiary.

HENRY W. HALDEN.—*Treatment of Spare Combs*.—Spare combs, if containing neither honey nor pollen, will never be attacked by moth. If containing pollen, spray with a weak solution of carbolic acid or phenol before storing them, and stow them away in a dry room or closet.

C. HARRBERSHAW.—1. *Queenlessness*.—We fear your hive is queenless. It is just possible that there may be a young queen in the hive, but forty-eight hours' absence of the queen would be sufficient to cause the bees to build queen-cells, when the old queen would be refused, as was the case. Why not examine the hive, if a bar-frame, and ascertain the fact? If found to be queenless, you can either allow the young queen to hatch, and take her chance of becoming fertilised, or a fertile queen may be introduced, by the usual and only safe method of caging upon a brood-comb, all queen-cells having been cut away. 2. *Changing Queen*.—The hive in which you could find no brood in June and July was evidently changing its queen. The young queen having successfully mated, the colony is now flourishing.

W. M. M.—*Syrup and Honey*.—We find, by practice, that 5 lbs. of sugar to one quart of water—made into syrup according to the usual recipe—are equal to about 3 lbs. of honey, as food for bees.

J. COOK.—*Washings of Combs*.—The washings of your combs will require, according to your description, 3 lbs. of sugar to a quart of the 'washings.'

WALTER WALSH.—*Foul Brood*.—You will find your questions answered in our issue of Sept. 1 in 'Useful Hints,' under the headings, 'Autumn Treatment of Hives Infected with Bacillus Alvei,' and 'The Treatment of Infected Skeps.' It is not too late for you to apply the remedy.

A. BEHNNER.—*Willesden Cord*.—This may be obtained at Messrs. Spalding and Hodge, 34 Cannon Street.

A. ROBINSON.—The sample of sugar forwarded will make good syrup. But we prefer the refined crystallised sugar, as containing more saccharine powers, and being less chemically treated.

F. McK.—*Winter Passages*.—There should be one or two holes,  $\frac{3}{4}$  of an inch in diameter, cut through each comb about 4 inches from the top. These holes can be made by a tube of tin, serrated like a saw. (See Cowan's *Guide-book*, page 148.)

F. W. TOMESON.—Mr. Fox Kenworthy, The Park, Ealing, is the Secretary of the Middlesex B. K. A.

J. T. G.—1. *Centaurea nigra* (the common and black Knapsweed). 2. *Scabiosa succisa* (Devil's Bit Scabious). You may be sure, if these plants are frequented by the bees at this time, that they must be valuable.

B.—1. *Calluna vulgaris* (common Heath or Ling). This is the plant from which the bees get the far-famed heather honey. 2. *Erica tetralix* (Cross-leaved heath).

This heath is a honey plant, but it yields a different kind of honey from the former.

E. Z. SYNGE, Co. Wicklow.—1. *Moving Bees*.—You can move your bees now by making an artificial swarm, and putting it until night on the old stand, removing the old stock to its new location. At night put the swarm close to the old stock in its new position. In three days' time reunite. 2. *Wintering*.—Bees must be 'wintered' on their permanent stand; do not shift them. The aspect is not of much consequence, so long as they get sun-hine. Do not put your bees in a house. 3. *Unsting*.—No. The bees must take the scented syrup. Turning up a skep is not the dreadful operation you seem to think. You will find it easy enough.

A. WALLACE, Parsonstown.—1. *Condensed Bees*.—Give them syrup only; they will get pollen for a few weeks, enough to supply the brood which they raise. Do not feed heavily until the combs are built out, and be careful that they are not so unequally loaded that some break down. Half a pint a-day is enough to give at first. 2. *Pollen Gathering*.—Yes, as a rule, but not always; pollen is consumed by adult bees. 3. *Brood-comb*.—Brood must not be separated from the bees for an hour. Take with you a frame of wood  $\frac{1}{2}$  inch wide, covered on one side with wire-netting, and a piece of netting to cover the other side. Put the piece of brood-comb between the netting, and suspend the whole in your box of bees. If the pieces fit pretty well they will be joined into one sheet, and the brood hatched out. 4. *Age of Queen*.—By her history. The old queens go with swarms, therefore stocks which have swarmed and casts have young queens. 5. *Scented Syrup*.—Add a few drops of any kind of scent to the syrup and shake up. 6. *Hybrids*.—A first cross is as good as, or better than, a pure race. 7. *Killing Queens*.—No. The fittest will survive.

MISS F. FITZGERALD.—If you are unable to discover the younger of your two queens, there is no alternative but to allow them to fight it out.

GEORGE D. CLARK.—The Secretary of the East of Scotland B. K. A. is Mr. J. W. Ward, 23 Pannure Street, Dundee.

W. MITCHELL. We are pleased to comply with your desire of August 30th.

W. PEARS.—*Heather Honey*.—In order to get the honey from the cells, cut them across, and afterwards chop them into small pieces; put these into a conical bag, hang up before a warm fire, and the honey will exude.

G. E. ASHBYRNER.—*Beginning Bee-keeping*.—We would suggest that at this season it would be desirable to acquaint yourself with the literature of bee-keeping. By studying such works as the *British Bee Journal*, *Modern Bee-keeping*, Cowan's *Guide-book*, &c., you would become acquainted with the physiology of the bee and the economy of the hive, and would be prepared to commence bee-keeping in earnest next spring.

Samuel Bagster, jun., wrote a work entitled *The Management of Bees*, which passed through three editions—1844, 1848, and 1867. Bagster is said in a biography by J. Broad to have 'issued a selection of moral and religious lessons founded on the customs of bees extracted from a work by Samuel Purchas, and first published in 1657.' Has any bee-keeper seen the above-mentioned 'Selection?' The Editor would be obliged by any information respecting it being forwarded to him.

\* Various communications have been pressed out by our report of the discussion on Mr. Helmer's paper, amongst others letters from Mr. Broughton Carr, 'The Plate-layer,' and Mr. H. Mills. These will appear in our next.

# THE BRITISH BEE JOURNAL

Communications to the Editor to be addressed 'STRANGEWAYS' PRINTING OFFICE, Tower Street, St. Martin's Lane, w.c.'

[No. 157. Vol. XII.]

NOVEMBER 1, 1884.

[PUBLISHED FORTNIGHTLY.]

## Editorial, Notices, &c.

### QUARTERLY CONFERENCE.

At the Quarterly Conference of the Representatives of Affiliated County Associations with the Committee of the B. B. K. A., held at 105 Jermy Street on the 22nd of October, Mr. W. H. Dunman, the Hon. Sec. of the Dorsetshire Association, made a further advance towards the solution of the question of representation, which we think deserves the attention of our readers.

We must congratulate Mr. Dunman on the general result of his motion, though he failed to carry all the points which his resolution contained; and we must also compliment him on the tenacity with which he stuck to the fourth clause of his resolution, viz., that relating to the length of notice to be given to county secretaries of all questions to be brought forward at the Conference. Mr. Dunman's motion was divided, for convenience of discussion, into four clauses.

Clause 1. That any four County Associations should be allowed to form a union, and to send up one representative in turn to each quarterly meeting to represent the union.

This clause was carried by the Conference. The four counties originating the idea were those of Dorset, Devon, Somerset, and Cornwall. No one, we think, could reasonably take any objection to this scheme as a matter of convenience for County Associations themselves, and also as ensuring the presence of a representative of each county in the union at one of the four conferences held in the course of the year. For this reason, it seems a proper step to limit the number of counties to be included in such unions to four. Each representative will thus have the opportunity not only of acquainting himself with the operation of the Central and Affiliated Association, but will also be able to bring forward any matters relating specially to his own county as well as those relating to the union generally. If representatives cannot be found to attend four meetings in the year, it is better to have a representative who will attend once in the year than not at all.

Clause 2. That each representative should have a vote for each county he represents.

This clause was not carried, and in our opinion wisely. - at all events, until the counties generally have thought well to adopt the union system.

Clause 3. That no individual county shall be entitled to have more than one vote at the Conference, though it may send two representatives.

This clause was also rejected, from a feeling that it was unjust to curtail the existing rights of County Associations in order to suit the convenience of others.

Clause 4. That notices of the agenda to be discussed at each Quarterly Conference should be sent by the Secretary of the B. B. K. A. to each County Secretary one month before the date of each Conference.

This is the clause to which Mr. Dunman adhered with such tenacity, and which, with a deduction of seven or eight days, he succeeded in carrying. We cannot ourselves see that its effect can be otherwise than for good, and we think that its advantages will outweigh its disadvantages.

At this Conference the advantage of allowing Associations to be represented by members not necessarily residing in the county, was illustrated by the appearance of the Rev. Alexander A. Halley, a resident in the metropolis, as the representative of the Nottinghamshire Association. We ourselves think that this plan gives the greatest facility of representation to county's distant from London, and ensures the protection of their interests better than the attendance of a representative once a year. But the plan advocated by Mr. Dunman may prove to be more feasible, and it is well to give a fair trial to every scheme for representation in order to perfect our organization, as far as perfection may be attainable.

### HONEY CROP OF THE UNITED KINGDOM.

Now that bee-keeping is being raised to a vocation and consolidated into an industry, and now that bee-farms are being established and honey companies are visibly booming at no far-off distance, it is desirable that there should be some statistical report of the honey production of the United Kingdom. As the intelligent bee-keeper considers it duty to obtain a clear record of the produce of his apiary, so is it desirable for the apicultural community to have a report of the honey harvest of the nation. Such a report would enable us to determine to what extent the land in which we live is honey-producing, and it would furnish some groundwork





different counties. He therefore submitted the following resolution for consideration—'That it is most advisable that County Associations should be always represented at the four quarterly meetings of the B. B. K. A., and that in order to enable them to do so they should be allowed to unite, and that one representative should be enabled to represent more than one county; and that if there should be a case of voting he should have as many votes as counties he represents.'

The Committee of his own Association also thought that at least one month's notice should be given of any motion to be brought forward at the quarterly meetings. This would enable County Associations who wished it to meet and communicate their views on the matter to their representative or representatives. He would formulate a resolution in accordance with this view after a vote had been taken on the motion before the meeting.

Mr. Griffin seconded the motion, and Mr. Sambels, Mr. Garratt, and the Rev. V. H. Moyle, supported it; while Mr. Stewart, Mr. Hooker, and the Rev. Mr. Jenyns, opposed it on the ground that the conferring of a plurality of votes on one representative would invest that gentleman with too much power, who would in reality be only a delegate from two or three or more different counties, compelled to vote according to the directions of his constituents, and consequently not permitted to exercise his judgment unfettered at the meetings.

Mr. Dumman's resolution was eventually divided into two parts, and put to the meeting as follows: moved by Mr. Dumman, seconded by Mr. Griffin, and carried by nine votes against one—'That it is most advisable that County Associations should always be represented at the four quarterly meetings of the B. B. K. A., and that to enable them to do so Associations should be allowed to unite, and that one representative should be enabled to represent other Associations besides his own.'

Moved by Mr. Dumman, seconded by Mr. Griffin, but negatived by six votes to four—'That should there be any case of voting, each representative should have as many votes as counties he represents.'

Mr. Dumman then moved, and Mr. Griffin seconded—'That notices of every quarterly meeting of the B. B. K. A. be sent out to County Associations one month before such meetings.'

Mr. Stewart pointed out that it was not necessary to give more than fourteen days' notice of a general meeting, which was of greater importance than a quarterly meeting. He objected to the motion, and said that the effect of it would be to postpone the consideration of many subjects until all interest in them was lost. A matter of pressing importance in May could not be dealt with, supposing the next quarterly meeting were held at the beginning of June, until the following October, when very likely no benefit could be derived from the discussion thereof.

Mr. Hooker said that Mr. Dumman's proposition could not be carried out unless Clause 2 of the Privileges of Affiliation were altered, because that clause permitted notices of motion to be given within fourteen days of any quarterly meeting at which such resolutions were to be discussed. This rule would obviously prevent the agenda of each meeting being forwarded to county representatives one month before the date of meeting.

After some further discussion, Mr. Dumman assented to this resolution standing in the following form, when it was put to the meeting, and carried by twelve votes against two—'That it is advisable that the Secretary of the B. B. K. A. send out the agenda paper twenty-one days previous to every meeting.'

In reference to the second item on the agenda, viz. 'A proposal for publishing the bound volumes of the Annual Reports,' the chairman said he thought there was a feeling that it was desirable, if possible, to lessen the burden on County Associations of furnishing so

many copies of their report for the purpose of being bound together with those of other Associations, and he would be glad to hear any suggestions thereon. Mr. Griffin, Mr. Dumman, and Mr. Brown stated that the Associations they represented would be happy to supply gratis as many as seventy copies of their reports for binding purposes. No decision was arrived at on this point, the chairman recommending that the subject should be thought over by the members before they met again.

In regard to item 7 of the agenda, viz. 'The prosecution of the vendors of adulterated honey,' Mr. Huckle begged that all persons interested in the objects of the Association would be on the look out for samples of honey suspected of being adulterated and communicate the particulars to him, in order that steps might be taken to prosecute the vendors. The chairman recommended that a list of public analysts should be procured and published in the *Bee Journal*.

There were several other subjects on the agenda for discussion; but owing to the lateness of the hour, and the Board-room being required for the Conversation which was to follow, the consideration of such matters was adjourned until the next quarterly meeting.

#### CONVERSATION.

Soon after six o'clock the Committee and County Representatives reassembled, their number being augmented by several ladies and gentlemen interested in bee-culture. The proceedings of the evening comprised the reading of a paper by George Walker, M.R.C.S., L.R.C.P., 'On Feeding Bees,' and the discussion thereon.

Mr. Dumman (Dorsetshire) having been called to the chair, opened the proceedings. He said he felt it an honour to preside on the present occasion as a representative of one of the oldest bee-keeping Associations. He congratulated them on the excellent honey season they had all experienced this year, and said their first thought must now be to take care of the bees during the approaching winter. He looked forward to a most instructive lecture from their friend, Dr. Walker, on the subject of feeding bees. It was most important that bee-keepers should be rightly informed as to the time when bees should be fed, the ways of feeding them, and the material their food should consist of. He would not therefore occupy any more of their time but call on Dr. Walker to address them.

Mr. Chairman, Ladies, and Gentlemen,—The subject I have chosen for my paper this evening is on 'Feeding Bees,' and I have chosen this subject, not because I have any new facts to demonstrate, or new theories to prove, but because I wish the B. B. K. A. to show to all bee-keepers that, by allowing me to read this paper at their quarterly meeting, they believe that one of the chief aids to successful bee-keeping is, that of knowing when and how to feed bees.

During some twenty years' experience as a bee-keeper, I have found, as most likely all you present have too, that in spreading bee-culture among all classes, both high and low, we have an amazing amount of ignorance to contend against, and perhaps never more strikingly shown than in the art of feeding. Not that bee-keepers from the time of Columella down to the time of our friend Mr. Cowan, have not insisted on the importance of the subject—they have done so; but it has been 'caviare to the general'; and though I find young bee-keepers do not spare their money in buying all kinds of bees, any new-fangled hive, or useful or useless appliances, the supplying their stocks and swarms with sugar is the shibboleth at which they stumble. Again and again I have found in the early spring stocks simply starved. I have examined them just when the genial spring has covered the earth with a carpet of flowers, and found little or no honey in the hive. I have advised careful feeding, but it is like music to the deaf adder, which



will not hear 'the voice of the charmer, charm he never so wisely.' And when I have looked at them a few weeks after every bee was dead. This has been, I am sorry to say, an oft-repeated tale, and so I make no apologies in bringing the subject of feeding before your notice.

The subject divides itself naturally into three heads—what to feed with, how to feed, and when; and I propose to sketch briefly each of these.

Honey consists of two forms of sugar, called dextrose and levulose, with about 20 per cent of water. It is not found in the nectaries of plants, but the cane sugar which they collect is changed by some substance in the body of the bee akin to diastase. The same process takes place when we add some dilute acid like sulphuric or tartaric, but it is difficult to get rid of the excess of acid. How far this small amount of acid would be deleterious to the bees I cannot say, as I have never fed bees with grape-sugar, though it is highly spoken of owing to its cheapness and its similarity to honey. The ordinary cane-sugar is what is generally used either in the form of syrup or in the form of candy. The brown sugar of commerce contains more saccharine matter than the white refined sugar, but it is said not to suit the bees so well, as it sometimes induces dysentery. The advantage of dry sugar feeding is that the bees will often take it when they will not take syrup, taking care to provide them with water to dissolve the sugar. Syrup is made by dissolving sugar in the proportion of 1 lb. to a quart of water, adding a half a wineglass of vinegar with a pinch of salt, and boiling for twenty minutes. In the spring and late autumn it is better to add more sugar, as the bees are not able to get rid of the excess of moisture. If we have that dread of the bee-master to contend with, foul brood, we shall have to add either salicylic acid or phenol. To make the former we dissolve one ounce of salicylic acid and one ounce of soda borax in two quarts of water, and add two tablespoonfuls of this solution to two pints of syrup. The phenol solution is made by taking one ounce of Calverley's carbolic acid crystals, No. 1, melting them in a cup placed near the fire, and then dissolving the acid in a quart of water, and adding three teaspoonfuls of this solution to a quart of syrup. As the bees sometimes will not take this medicated syrup, it is better to oblige them to take it by spraying it over the combs.

In the early spring and late autumn, if there is a deficiency of food in the hive, we shall have to resort to feeding with barley sugar or candy, and pen-cake, as we wish to give the food in a highly concentrated form. Barley sugar is made by melting sugar with little or no water, till it begins to change to a light straw colour; it is rather a difficult process, as if the boiling is continued too long, caramel is formed, very useful for flavouring soups, but not for feeding bees, as it is likely to cause dysentery.

Pen-cake is made by adding 1 lb. of pen-flour to every 6 lbs. of sugar, adding not quite a pint of water, and keeping the mass well stirred to prevent burning, the pen-flour having been added just when the sugar is dissolved, and taken off as soon as the excess of water is driven off, and is poured into saucers or soup-plates covered with paper, which prevents the sugar sticking. This placed over the feeding-hole or between the bars forms a very useful food for stimulative feeding, the pen-flour approaching very nearly in composition to the pollen of plants, containing a large amount of nitrogen indispensable for brood-raising.

Gentlemen, you know that within the memory of man the art of healing has made enormous strides, and that a great part of this progress is due to the discovery of various anaesthetics. So important is their use, that in all our large hospitals a special officer is appointed for their due administration, and the highest praise that could be accorded to such a man would be, 'He did

not invent a new machine.' For when we come to bee-feeders their name is legion, every one seems to have some new method, and all new bee-keepers are on the look out for the perfect feeder; one of the simplest is a bottle which is filled with syrup, and then inserted over a vulcanite stage, which is perforated in such a manner that the bottle covers one or more holes, allowing the bees to take the syrup slowly or quickly.

As far as my experience goes this is much preferable to those feeders which are put over a hole in the top carpet so as to allow the bees to come up. My objection to this class of feeders is that a large amount of heat is wasted and so much food has to be consumed to keep up the heat of the hive. The feeder which I prefer—and I am sorry not to be able to tell you its inventor's name—is simply a wooden block made like a bar, but wider, being about two inches in width, a trough is made either by using a saw commonly called a 'wobbler,' or by means of a centre-bit and a gongee, one side being lower than the other to let the bees get at the syrup; and if the trough is of any depth it is better to have a float to prevent the bees being drowned, and also to divide the trough into two parts by a vertical division; from the smaller of which the bees are excluded, and into which the syrup is poured and flows into the larger division through a hole cut in the bottom of the partition.

The advantage of this form of feeder is that the heat of the hive is not wasted, the feeding can be slow or fast, and we can refill it without disturbing the bees, by cutting a flap in the carpet just over the smaller chamber.

Like the Athenians of old, we are always eager for any new thing, and I have tried several new feeders, only to be disappointed. Each and all seem to have some defect; and I am afraid they are made not for use, but to sell. The disadvantage of the wooden trough feeder is that it takes up a good deal of room, but, as a rule, when all the space in the hive is wanted, feeding is not.

And now, gentlemen, in conclusion, I come to the most important question, When to feed. Again and again I am asked, 'Of course, you feed your bees in the winter?' And again and again I reply, 'Never, or hardly ever.' As I said before, bees are starved though want of feeding, but we must not fear that many are lost through the mistake in kind, so of those who disturb the hives by supplying sugar when the bees are liberating.

In our changeable climate we often find great alterations of temperature in the course of a few days, and after a cold spell we get a burst of sunshine, which deludes the hapless bees with the idea that spring has come in the middle of winter, and so we must be always ready to guard against this by having barley sugar or pen-cake, in case the food should run low. If we have taken care to supply the bees with sufficient food we shall avoid the Scylla of starvation as well as the Charybdis of candy; for if we stimulate the bees too soon in the spring we shall, if it is true, induce early brood-rearing only at the ultimate ruin of our hives.

It is impossible to fix any definite time for commencing feeding, as it depends entirely on the season, but our best criterion is the conduct of the bees themselves, as if we find them flying out of the hive about the end of February or the beginning of March we must examine the hive some fine day to see if the bees have commenced brood-raising; if so, we can stimulate them by first uncapping some of the honey-cells, and then, when their supplies run short, by giving barley-sugar pen-cake or dry sugar in a feeder close to the brood-nest, changing this to syrup as the bees begin to fly out of their hives, for while the weather is cold the bees will take barley sugar when they will not take syrup. So, too, we may supply pen-flour, so essential for feeding the brood, either by mixing it with the dry sugar, or by

sprinkling it on shavings placed in a skep or box. As each pound of comb necessitates the conversion of some twenty pounds of honey or syrup, immediately the bees begin comb-building we shall have to supply syrup in large quantities to work out the sheets of foundation, taking care that the feeding is not so rapid as to induce their making a large amount of drone-comb, though the worker foundation will prevent this to a great extent. Thus, by careful feeding and judicious increase of the brood-nest, by placing bars of foundation or comb between two bars containing brood, we are enabled to get the lives full of bees to take advantage of the honey harvest, and in those places where the chief crop is from fruit blossom we shall have to be earlier in this stimulative feeding, than where the crop is obtained from limes or heather, and it is difficult to drum this fact into the minds of young bee-keepers. They see that there are several of our early flowers in bloom, and the need of feeding them is a mystery. The main object is, of course, to get as many bees as possible by the time of the honey harvest, the more bees we have the easier is brood-raising carried on, and, as a consequence, the more spare bees to collect the honey, and never is the necessity more shown than when, as often happens, we have a mild spring followed by rather a cold summer. Again and again I have seen stocks not nearly so strong at the end of June as they were at the end of April, and so we ought to have our fingers constantly on the pulse of the hives, and feed when there is the slightest check, moderating the feeding so as to prevent the bees storing it away, but giving just enough for their daily wants.

Of course, when sections are on the hives those of us that have an unaccommodating conscience will be chary of feeding, and if we are obliged to do so it ought to be with honey, pure and simple, not mixed with hops-burd.

The advisability of feeding swarms has been constantly insisted upon, and the reason is not far to seek, for, as I mentioned before, the process of comb-building is very expensive, and by feeding we can give the queen a large amount of space available for laying eggs. The common plan, and the good one, is to feed the bees for the first four or five days, or longer if the weather is cold. By that time the swarm, if a strong one, will, owing to the comb-building instinct which is always strongest at that time, have filled with comb a mod-r sized hive, say of ten bars. After the comb is well filled out we must only give a small amount of food, to prevent the bees filling up the vacant cells.

By this plan, if our honey harvest is late, we can manage to make our swarms as strong as stocks; and so if, after feeding as above, we put sections on we can often get a good crop as from an old stock.

The autumn management of bees consists in prolonging the breeding season; as the young bees which are hatched out late are better able to stand the winter, and, what is more important, perhaps, to survive till the young bees are hatched out in the early spring, as that which is called 'spring dwindling' depends upon the fact that the young bees are not hatched out in sufficient quantities before the bees that have wintered have died. Again, the more bees there are in a hive the less expenditure of food to keep up the necessary heat; and so, by stimulative feeding a hive which is described above we keep the queen breeding till October. In ordinary seasons I commence this feeding about the middle of August, and then about the beginning of October I examine the hives, and feed rapidly, so as to give a ten-bar hive about 25 lbs. of stores for the winter.

Stocks can be wintered on less, and I have frequently wintered bees which had not so much, but it may be taken for granted that it is better to overfeed, as supposing some is still left unconsumed in the spring,

by uncapping the cells the queen can be stimulated, or the surplus stores can be used for other stocks. Redistribution, in fact, without the franchise.

Mr. Chairman, Ladies, and Gentlemen,—I have to thank you for the kind attention with which you have listened to this paper, and, believe me, the pleasure I have had in writing it will be enhanced the more, if the subsequent discussion tends to advance, even in a slight degree, that which we all have most at heart,—the progress of bee-culture.

[We are obliged to postpone the discussion till our next issue.]

#### GRANTHAM HONEY FAIR.

This great annual fair was held in the Westgate Hall, Grantham, on Oct. 18th, and was opened by the Mayor (G. S. Hannett, Esq.), with some most appropriate remarks, which were responded to by the Rev. C. P. Plumpton of Claypole, and Mr. R. R. Godfrey of Grantham. The Mayor (accompanied by the Mayoress) paid a visit to the various stands, making large purchases, and showing in a practical manner his sympathy with the movement. There were 4141 lbs. of extracted and comb honey—a little less than two tons—entered for the fair. The total weight of honey pitched was somewhat less than the previous fair, but it was very satisfactory to find that the number of vendors was far in excess of last year, there being forty on this occasion, as against twenty-five twelve months ago. The great variety of the lots, the different modes of putting up, and the many colours and quality of the honey, could scarcely fail to suggest to the bee-keepers present some profitable lessons. Sales went on in a very lively fashion, and the result revealed clear boards and good prices, except in the case of three or four heavy lots, where the owners had to pack some of it up again unsold. The average price of extracted honey was about 9d. per pound, and of honey in comb 1s. per pound. Only a limited quantity of wax was on sale, and that of inferior quality. This is to be regretted, as at past fairs the demand has been brisk, and good prices have been made for clean stuff. Amongst the chief exhibitors were Mr. Truss, of Lainton, near Stamford, who pitched the largest weight, viz., 600 lbs. Following him were Mr. Gilbert, with between four and five hundred pounds; Mr. R. Thorpe, 310 lbs.; Mr. Cooley, 290 lbs.; Mr. Shadford Lee, Cunningham; Rev. F. Ashwin, Quadring; Miss Deedes, Heydour; Mrs. Brown, Whaplode; Miss Hanson, Whaplode; Rev. R. Hollis, of Whaplode Grove; Mr. Nix, of Azby, &c. Mr. J. W. Bickley, a Meltonian bee-keeper of note, staged some of his usual grand supers. Mr. Rippon, of Crowland, pitched a nice lot, put up neatly in glass jars, the quality of which was very fine, and commanded a ready sale. The Rev. C. P. Plumpton, of Claypole, had a good display of sections and extracted honey, all of which was sold. A prime lot of heather honey—the honey of all honey for the table—from Mr. Yates' moor apiary, claimed marked attention, and realised the top price in the fair. Since heather honey is so preferable to other kinds for the table, we shall not be surprised to hear of such apiarists as Mr. G. Brown, of Swineshead, Mr. W. Martin, of Wainfleet, Mr. R. Thorpe, of Langrick, and other large bee-farmers, introducing their busy workers to the wilds of the heather bloom. Mrs. Brown, of Whaplode, is a great enthusiast in the work; she is in the habit of visiting many cottagers, to instruct them, and her presence at an exhibition is always welcomed. Mr. Ball (the hon. secretary of the Leicestershire Association), and his wife, rendered great assistance: the latter making a capital saleswoman. Dr. Eaton, who throws much life and interest into the proceedings at our fairs and exhibitions, was most successful in sales. The arrangements, which were most satis-

factory, were carried out by Mr. Bolton, assisted by other members of the Association, to whom great credit is due. The benches were arranged in rows on each side of the hall, with cross-benches down the centre. At the end of the hall, choice plants, interspersed with various lots of honey, were tastefully arranged upon the platform.—*Extracted from Grand-ham Journal, Oct. 26.*

#### SUFFOLK BEE-KEEPERS' ASSOCIATION.

On September 15th the fifth annual show of bees and bee-keeping appliances in connexion with the Suffolk Bee-keepers' Association was opened at the Old Museum Rooms, Museum Street, Ipswich. The Association was started in May, 1880, and each year has been attended with growing success. The present show was to exception to this rule, and there was a larger and better display than on previous occasions.

The first kind of exhibits to which prizes have been given are the hives and appliances. Mr. S. J. Baldwin secured all the first prizes in these classes. For the best collection of hives and bee furniture most applicable to modern bee-keeping his was the only exhibit. For the best Observatory hive, for which the first prize was given by Mr. Cuthbert Quilter, he showed a large structure, which possessed the advantage of taking three standard frames, and was filled with a strong stock of Ligurian bees. Mr. Andrews, Haughley, who took second, showed a very good hive stocked with excellent British bees, but it was not nearly so large as that of Mr. Baldwin's. The only Cottagers' hive shown was a capital specimen of workmanship, and well deserved the prize it won.

The honey classes were very well filled. The season during the earlier part was favourable to the honey-producer, but the drought, which caused the flowers to die prematurely, militated against success later on in this part of the country. The principal prize of the day was the silver medal given by the British Bee-keepers' Association for the best twelve 2-lb. sections of comb-honey, which was taken by Mr. R. Riv, Wallingford, in a strong class. The bronze medal and the certificate were both awarded to Mr. H. Kerridge. In the twelve 1-lb. sections, for which there were twelve entries, Mr. Kerridge secured first prize with some neat and well-filled combs. For the best six 2-lb. sections Mr. Bower took both of the two principal prizes, showing some very perfect specimens, whilst Mr. Howard, with some remarkably white honey, secured first for six 1-lb. sections, though there was little to choose between the exhibits.

The supers sections excluded were a highly meritorious class as a rule, and the prize-winners showed excellent specimens, whilst a very fine one was sent by Mr. E. Bowers, not for competition. The cottagers' show of supers was poor, and no first or second prize was awarded. The same remark did not, however, apply to the sections or to the extracted honey, both of which were very creditable. The show of wax was good, and it was exhibited in various artistic shapes, whilst Mr. Riv showed a neat collection of dried bee-flowers. The exhibits were judged by Rev. G. Raynor, Hazeldean, Maldon, and Mr. J. A. Smith, Rise Hall, Alkham. The duties of secretary were ably carried out by Mr. H. Kerridge.

#### WEYHILL HONEY FAIR.

The bee show in connexion with the Weyhill Fair opened on October 11th and closed on the 15th. One end of the tent was screened off for the honey fair and open to the public, admission beyond being 3d., the usual charge at the other shows on the fair ground.

Among the novelties to be met with on the ground was an exhibition of bees, bee appliances, honey wax, &c., announced to be under the joint management of the Wilts and Hants Bee-keepers' Associations, but which in reality was managed by the Rev. W. E. Burkitt, of Bartermore Rectory, Hungerford; and Mr. Hart, of Longstock.

These exhibitions tend to an increased interest in bee-keeping, as was proved by an incident brought under our notice. Two years ago a local gentleman was so taken with the modern appliances that he obtained some, and in the first year obtained 150 lbs. of honey. This year, however, the result of his bee-keeping has been over 700 lbs., a considerable improvement in so short a time. With regard to this exhibition, we may say that the appliances shown by Messrs. Hart and Co., Longstock, and the Rev. W. E. Burkitt, afforded the utmost interest, and were inspected by a number of spectators who visited the tent during the fair. Mrs. Best, of Red Rice, forwarded a large observatory hive, which afforded the means of watching the bees at work. Another interesting feature was Gibbons' improved observatory hive, which allows of the bees being seen in an ordinary hive. The Buttermere skepnet, invented by the Rev. W. E. Burkitt as an aid to those who only understand the skep-hives, was pronounced a useful and cheap contrivance, while the other various appliances shown by the two gentlemen mentioned, and to which several prize certificates were attached, merited for general attention. There was a stall for the sale of honey and wax; about one ton of honey was offered, mostly of prime quality; and we were struck with one use to which honey was put. Many people complain that they do not know what to do with their honey except use it in its natural state; but here it was prepared in a different manner, and one that took from it that excessive sweetness which to many is sickly. The honey was mixed with bread-crumbs and then baked in tarts, &c., a light puff paste being used, with the result that the confection was in 48 hours to the taste it was also used as an ordinary jam for puddings, &c. A large wholesale confectioner at Andover was so pleased with our honey tarts that he at once bought one hundredweight of honey for the purpose of making them for sale. At intervals during the day, lectures on modern bee-keeping were given, and altogether we fancy the promoters of the exhibition have accomplished their desire to increase the interest in bees and bee-keeping on modern principles.

#### ESKDALE BEE-KEEPERS' ASSOCIATION. HONEY SHOW.

At the Eskdale and Liddesdale Agricultural Show, held on October 14th, there was an exhibition of honey and bee appliances, under the auspices of the recently formed Eskdale Bee-keepers' Association, which was held in a spacious tent, and formed a most attractive spectacle. The entries were large, numbering fifty-seven of honey and five of hives. The quality of the honey was exceptionally fine, the past season having been the best for many years. The Rev. F. Taylor, Kirkcaldy, judged the exhibits; Mr. Arthur Bell, Hillside, being attending member. The following is a list of the awards:—

Six 1-lb. Sections—1, Thos. Gaskell, Murthohn; 2, Arthur Bell, Hillside; 3, John Scott, Alma Place. Twelve 1-lb. Sections—1, Thos. Gaskell, Murthohn; 2, Arthur Bell, Hillside; 3, Robert B. Gilroy, Langholm. Six 2-lb. Sections—1, James D. Glenfing, Langholm; 2, Thos. Wilson, Sawmill; 3, Arthur Bell, Hillside; h.c., Wm. Harkness, Kenra. Twelve 1-lb. Sections—1 and h.c., Wm. Harkness, Kenra; 2, Ninian Wilson, Langholm; 3, Arthur Bell, Hillside; h.c., Thos. Gaskell, Murthohn. Straw Super, any weight—1, John Connellar, Skippers; 2, Robert Brown, Skippers. Super (not straw), above 6 lbs.

--1, 2, and h.c., W. Harkness, Kemra; 3. M. Carthew-Vorstom, Irvine House. Run or extracted honey, in glass jars, the whole not under 6 lbs.—1, Thomas Wilson, Sawmill; 2, Wm. Harkness. Special prize for supers under 6 lbs., worthy of merit—Mrs. Connell, St. Thorwald's. Bar-frame hive, with cover, stand, and facilities for storing surplus honey, price not to exceed 20s.—1, George Cummin; com., Robert Beattie.

#### HUNTINGDONSHIRE BEE-KEEPERS' ASSOCIATION.

A meeting of this Association was held on Tuesday evening, Oct. 7th, at the Fountain Hotel, Huntingdon, when rather over thirty persons were present. This was the largest gathering of members since the formation of the Association, and it may be taken to indicate that the occupation of bee-keeping is greatly on the increase. It was stated that the Association numbers seventy members in various parts of the county. Amongst those present were the Earl of Sandwich (President), Mr. A. W. Marshall (Ex-Mayor), the Rev. C. G. Hill (Warboys), Rev. — Thompson (Offord), Major Roper, Mr. J. Linton, &c. After his lordship had distributed the prizes, Mr. A. Sharp, of Huntingdon, read a most able paper on 'Practical Bee-keeping.' Mr. Howard, of Holme, kindly promised to act as expert until the funds of the Association allow of the appointment of a paid expert. At the annual meeting in January, Mr. Howard will give an address on 'A Cottage's first Steps in Bee-culture.'

### Correspondence.

All Correspondents forwarding Letters for insertion in the Journal, Reports of Associations, Shows, Meetings, Exhibitions from Bee Hives, Queens, &c., are requested to direct their communications to 'The Editor of the "British Bee Journal," c/o Messrs. Strangers & Sons, Tower Street, Upper St. Martin's Lane, W.C.'

#### OUR HONEY IMPORTS.

The value of honey imported into the United Kingdom during the month of September, 1884, amounted to £477. From a private return sent by the Principal of the Statistic Department H. M. Customs to E. H. Bellairs, Wingfield House, Christchurch.

#### TESTING WAX.

The little test which you were good enough to insert in the last number of your *Journal* should be used with some caution in two respects. First, great care should be taken that the wax-pellets be free from enclosed air-bubbles; and second, that by contact with the hand they should not have become sensibly warm. Both circumstances might become sources of error causing genuine wax to float in the spirit, and thus to assume the character of the paraffined article. In order to avoid it, I would advise little blocks, not too small, be carved for testing, not to be moulded by hand.

Inattention to these precautions caused me to suspect the foundation made by an eminent firm, Messrs. Abbott Bros., as impure, whilst on subsequent analysis the article was found to be quite genuine. As my suspicions were publicly uttered, I deem it but right to remove them as openly. My motto has ever been, 'Be just and fear not.'—OTTO HERNER.

#### ANALYSIS OF HONEY.

The following is a letter received from the County Analyst, Matthew A. Adams, Esq., F.R.C.S.:

*Ashford Road, Maidstone, 26th September, 1884.*

'Sample of Honey.'

'My dear Sir,—I have made a careful examination of

this sample—microscopical as well as chemical, and find the dark discoloration is due to *Tanno-gallate* of iron. The iron is present in very considerable proportion together with a small amount of *Tanno-gallio* acid; this latter, no doubt, was derived by the bees from the plants they frequented, the two substances producing a veritable "ink," but whence the iron comes is a puzzle. I find no other departure from normal honey.

To Ralph Franklin, Esq., Maidstone.'

#### QUEEN-INTRODUCTION.

It has always been considered an axiom in bee-culture that 'bees, when in a normal condition, will defend their hives against all enemies'—even against attacks of their own species. Whatever I have written against Mr. Simmins' method has been in defence of this principle. When, in your columns some time ago, I objected to his method, that this direct introduction was accomplished without the use of smoke—that the word smoke never once occurred in his pamphlet—his reply was that he did not wish it to be understood that he dispensed with smoke. But, as far as I am aware, he has not yet recommended it. I have no doubt that the American experiments were made without the application of smoke.

Now when bees are subjected to smoke they are no longer in a normal condition, the greatest confusion follows its application, and the bees no longer defend themselves, nor resent attacks or intrusion. Every tyro is aware of this fact, and I, with many others, have repeatedly and successfully smoked in queens at the entrance of the hive without any caging at all. No discovery of Mr. Simmins, then, was necessary to acquaint us with this fact. Nevertheless, it is not a method which I would recommend to a novice. Often, after the effect of the smoke has passed away, the queen will be sacrificed, hence great vigilance is required when practising it. Again, we all know that a queen may be safely entrusted to the care of young bees, newly hatched, or even up to three weeks old, when they begin to work in the fields. It is therefore an easy matter to introduce queens direct into nuclei, which usually consist of young bees, as also to hives which have recently swarmed, if they have been removed from their usual stand to a new position, so that all the flying bees are absent.

In none of these cases are the bees in a normal state. Therefore our axiom still holds; and I strongly suspect that the successes, reported by your several correspondents in your last issue, may be accounted for by one or other of these abnormal conditions. When in search of truth, personal considerations should be laid aside; and I beg to assure Mr. Bellairs that I have no personal animus against Mr. Simmins, but simply deemed it right to warn the unwary against a liberal interpretation, and putting into practice, of his method, especially without the use of smoke.

Let him assure his mind, since he need be under no apprehension that anything I may have written in this controversy can have a more disastrous effect—in deterring others from experimenting with the system invented by Mr. Simmins (I much less adopting it—than perhaps to induce some weak-minded apiarists to use the cage in preference to risking the lives of valuable queens. I feel sure his regret will be less when I say that with the cage my successes have been 97 per cent, and in 95 per cent of these cases the queens have been joyfully accepted after *twenty-four hours'* confinement, and have been in no way injured by their short imprisonment.

Let me also, in thanking Mr. H. O. Smith, of Louth, for his kind offer to 'give me a lesson in queen-introduction,'—which I fear there is no chance of my accepting at present,—beg to assure him that I have never sold a 'Raynor cage,' nor obtained the slightest profit from its sale. On the contrary, I have repeatedly given these

cages to novices, and some of them have been successfully used; but, except in the case of novices, I do not even recommend them, as I much prefer, in the hands of an expert, the Woodbury pipe-cover cage.—GEORGE RANSON.

#### CURE OF FOUL BROOD.

Having during the past week examined the three hives from which the queens were taken in which Mr. Cheshire discovered the infected eggs, I thought it might perhaps be of interest to some of your readers to learn that, although from the nature of the business of the gentleman to whom they belong not allowing him to give them the care and exact attention they should receive, yet two out of the three hives are completely cured, and there is but the faintest trace in the other. A queen was introduced into one of the hives at the same time the other was removed, and in that one there are a considerable breadth of sealed brood, and lots of young bees. The other two I was still before examination had about three weeks before had queens introduced by simply lifting the quilts and slipping queens in open match-boxes under them, and yet, to my surprise, I found that the queens had been well received, and that in both hives there was healthy brood in every stage. These cases were very bad, the smell being something frightful, but I am convinced that with proper care Mr. Cheshire's remedy is a perfect cure, but the queen must be removed and a healthy queen substituted in her place.—H. F. HAIR, *Longstock, Stockbridge*.

#### PHENOL NO CURE IN AUTUMN.

Having used carbolic acid as a prophylactic in the apiary for more than fifteen years, I was delighted to learn that Mr. Cheshire, by putting a little orange syrup and poking it into the holes of a virulently diseased stock, had succeeded in effecting a complete cure. To test its power in this way, I prepared a bottle of medicated material prepared under Mr. Cheshire's guarantee, and began to treat a stock, though foul-brooded, according to the method prescribed on the 30th August last.

Greatness were all favourable, such as a high temperature, a breeding queen, and bees carrying in pollen. No heat was allowed to escape from the stock through imperfect covering. But although the treatment has been carried on till now (Oct. 20th), there is no more abatement of disease than usually takes place when egg-laying becomes languid. The population is getting reduced; the cells perforated and closed are filled with grey, putrid matter, and the stench emitted is scarcely less offensive than formerly.

What the treatment can effect in spring and summer, when greater heat and activity prevail, remains to be tested; but from what has come under my observation I have come to the conclusion that unless the apiarian himself clear out every foul cell, no virulently diseased hive can be restored to perfect health in the autumn by administering phenol as Mr. Cheshire directs.

The best plan that I know of for saving the bees of a diseased stock at the end of the honey harvest is to put them in quarantine, in an empty hive, for thirty or forty hours, and then change them into a skep or box which has been well washed, or rather soaked, with a solution of chloride of lime, feeding them up as rapidly as possible. Many during the past month have got empty skeps well filled with comb and food. They may condemn what practice sanctions, but quarantine and chloride of lime never fail, when properly applied, to stamp out foul-brood disease, unless there has been something very exceptional in the experience of

#### IS PHENOL A CURE FOR FOUL BROOD?

I wish to lay before the readers of the *Bee Journal* my experience with Mr. Cheshire's cure for foul brood. About the time that Mr. Cheshire presented his cure to the public, I discovered that one of my five stocks was slightly infected with foul brood; and well had it been for me had I then at once followed the advice of Mr. Charles N. Abbott, that is, destroyed the stock of bees, and then burnt the hive, frames, quilt, and everything in use with it; but after reading Mr. Cheshire's paper I felt confident that I could without difficulty soon cure my stock; but I soon found to my cost that phenol used according to Mr. Cheshire's instructions would neither prevent nor cure foul brood. After coming to the conclusion that I would give phenol a fair trial, I sent for a bottle of 'Absolute Phenol' to Mr. Thomas B. Glow, Welwyn, Herts; and after making some syrup in the usual way, I gave them 'A' added phenol in a feeder, but as honey was then coming in I found the syrup refused by the bees. I then opened the stock and removed the brood comb, and holding them at about the incline of a writing-table, I poured them in a vessel with a tube the phenolated syrup into these cells immediately over and around the brood-comb. This I did daily, the bees using all the syrup as it was poured out; but alas! the disease only increased, and in a fortnight from the time I commenced to medicate the diseased stock, I discovered that the rest of my stocks were infected. Of course then began to medicate them all with phenolated syrup, hoping that I would overcome it in the end; but no, the disease only increased, the bees in each every day getting fatter, and at the end of four weeks from the time I first began to use phenol the combs containing brood had become a putrid, rotten mass.

So much for its curative power, I had now nearly lost faith in it, but resolved to try it as would prevent foul brood breaking out on fresh combs. I then shook my bees into empty skeps for a few days, in order to let them use any food they contained. I then thoroughly disinfected by fumigation all my five hives in which the bees were when ill, had a supply of new frames made for each hive, and inserted in each frame full sheets of comb-FOUNDATION. I then placed these frames with foundation in the disinfected hives and shook the bees which had been in empty skeps for three days into these disinfected hives, furnished with new frames, new quilts, and comb-FOUNDATION. I then began to feed with medicated syrup, and as the flow of honey was then nearly over I gave them 'B' phenol, and the bees took it pretty well. In a short time they had built out their combs, and the queen commenced laying in consequence of the stimulative feeding. I examined them regularly at intervals of three or four days, and hoped that foul brood would not trouble me any more. The brood-cells were duly sealed over, apparently healthy enough; but in a short time after being sealed foul brood again showed itself in all my hives, and at the present time is still raging. I am now afraid I will lose all my bees, as they are fast becoming very weak.

I have used Mr. Cheshire's cure, and followed his directions to the best of my ability, but it has proved in my case a complete failure. Had I destroyed my first stock when I first discovered it, I might have saved the rest. This has been my fifth year's experience with bees, but I never was troubled with foul brood before. ARTHUR B. JOHNSON, *Brick Hall, Killybegh, Co. Down*.

#### A YEAR'S REPORT.

I beg to present my year's report as follows: I started in the spring with eighteen hives, three of which were weak. From these I have taken 557 lbs. of honey—339 lbs. extracted, and 188 lbs. comb-honey; this gives an average of nearly 31 lbs. per hive; valuing the ex-

tracted at 6d. per lb., and the comb at 1s.—17. *Os. 8d.* per hive. But I must tell you that three hives were moved to a fruit farm called Nickle, and four to another farm, not specially a fruit farm, called Ensinge, while the eleven others, including the weak ones, remained here at the Hill. The Hill is 400 feet above sea-level, surrounded by oak-woods, with very little cultivated land. The eleven hives gave 71 lbs. comb, 178 lbs. extracted, a value of 14s. 6 $\frac{1}{2}$ d. per hive. Nickle, a fruit farm with saffron, &c.: the three hives gave 33 lbs. comb, 187 lbs. extracted honey, value 2*l.* 2*s.* 2*d.* per hive; the best hive here gave 95 lbs. extracted honey. Ensinge: four hives gave 84 lbs. comb, and 4 lbs. extracted honey, value per hive, 1*l.* 1*s.* 6*d.* I have three Stewarts besides, but they gave very poor results—52 lbs. comb-honey the lot; but they had but very little attention.

I have now packed twenty-one stocks in bar-frame hives for winter, with a fair but not full supply of stores without feeding. Seventeen of the queens are of this year's raising, which was done on the Hill by the eleven hives. As regards the quality of the honey, about half of it is very good in colour, &c., the other half is dark, more or less, some very dark.—JOHN MARTEN, *Dunkirk House, Faversham, Kent, Oct. 6.*

#### LIGURIANS AS HONEY-GATHERERS.

A good deal of discussion has taken place in your paper respecting the Ligurian bees, some say they are the best honey-gatherers, some that they are useless except for breeding purposes. I will tell you my experience with them. I commenced the spring with five stocks (all bar-frames), and have taken the following number of two-pouced supers from them, 1, 105; 2, 95; 3, 49; 4, 83; 5, 75.—388 supers, which average about 1 $\frac{1}{4}$  lbs. each, so that I have about 700 lbs. of super, and in addition to this 100 lbs. of extracted honey. Thus I have an average of 140 lbs. of super and 20 lbs. of extracted honey from each hive. My best stock gave me over 180 lbs. of super. No. 3 was *very weak* in the spring, and I thought of nixing it to No. 2, but tried to see what a weak stock would do: it is now the strongest stock I have. I do not think anyone can say that the Ligurians are useless after this. I only got one swarm, and that was from No. 5, the swarms from all the other hives I returned the same evening. My stocks are now all strong and have abundance of winter stores. I looked through No. 2 to-day, and two combs are now full of eggs, and the queen was busy laying more; the bees are flying just as they did in June, and bringing in lots of pollen from the ivy.—H. W. D., *North Turlton, Devon.*

#### A BEE-KEEPERS' EXPERIENCE.

My apiary had in the spring of this year nineteen hives, of ten frames each. A very successful season followed. On May 16th I put on my first sections, and on 31st took off my first harvest of comb honey. This grew before the season had closed (July 28th) to the respectable number of 672 one-lb. sections of sixteen hives. Three hives I kept entirely for extracting from frame supers of only six inches depth in the clear. From one of these frame supers on June 16th I took 25 lbs., on June 24th 29 lbs., and on 28th 27 lbs.; on July 7th 23 lbs., and on July 19th 14 lbs.—making a total of 118 lbs. from top of hive alone. I should add that this nine-framed super had the frames of comb built out last year, so there was nothing for the bees to do but store honey. My total yield from these nineteen hives stands at 672 one-lb. sections; 28 two-lb.—728 lbs. Extracted honey, 866 lbs.; total, 1694 lbs., or a little over three-quarters of a ton of honey, from nineteen hives. In prizes at Chichester, a second and a third. At Tunbridge Wells, four first-class and two second, one of which brought the bronze medal. Last Wednesday,

thanks to the kindness of the Rev. V. H. Moyle, my exhibits took an extra silver medal as the recommendation of the judges. The whole of my exhibits at Tunbridge Wells were purchased before the general public had inspected them; and the Rev. V. H. Moyle purchased my exhibit at Reading.

This is one side of the picture; now for shadow. On the 4th of August a neighbour, a farmer, asked me if I could shut up the hives while his men reaped the small field of oats adjoining my garden. He said the men were afraid the horses would be stung to death. The promise on his part to have the oats cut the next day reduced the risk of the excessive heat doing any serious damage. The hives were accordingly shut up. No men came that day, nor the next, and on Wednesday my worst fears were realised. On opening the hives, I found a mass of broken-down comb and bees. Perhaps you will say, 'Serve you right for shutting the hives up;' but you are not a village schoolmaster, or you would know that to keep the peace with all men, and let no one suffer at your expense, is not only a moral law, but a necessity. I did what I could. You love bees, Mr. Editor, and may judge of my feelings as I turned out live after live of honey, wax, and bees, in one sweet burial-blast. I did what I could. All bees alive I turned into an empty bar-frame with nine sheets of foundation, and three queens that seemed the most likely to survive, and a frame of brood (the least damaged I could find). The rest of the *debris* I set aside for feeding purposes; then braced my nerves for Tunbridge Wells. I think those who met me there little knew what a heavy heart lay under the smiling countenance. Here is the moral, Never, not even to oblige your mother-in-law, shut up your hives. My poor bees had the first claim on me for protection, and I blame no one but myself. The hive of bees (wonderfully mixed) have survived, and the strongest queen rules, her two rivals being ejected. Please abuse me well, but remember how I was circumstanced. Will I give up bee-keeping? Certainly not, though it may take some time to get a stock to the condition of my lost pets.—THOMAS STOTHARD, *Poyham, Bognor.*

#### THE SEASON.—SECTIONS THE RIGHT WAY UP.

The season of 1884 will long be remembered by bee-keepers in all parts of the kingdom as one of the best, if not the best, for the past decade. And that the market is just now somewhat overstocked is scarcely to be wondered at, considering the many tons of honey that have been sent in. If I rightly remember some one in the columns of this *Journal* recently estimated the total produce for the kingdom at 100 tons. My own impression is that this estimate is very considerably below the actual yield; indeed, judging from the tone of my correspondence, and what is written of the honey harvest in the agricultural, horticultural, and the apicultural press, it would probably be nearer the mark were the initial figure altered from a '1' to a '3.' But now that we have it what shall we do with it? 'Aye, there's the rub,' exclaims the producer; 'and it's difficult to get more than 1*l.* a-pound wholesale for sections just now, and one cannot be expected to take so little as that.' My dear sir, why not, then, sell it at that price, unless you wish to retain it on hand in view of a rise in value later on? Like many other apiarists, I have sold a pound or two of the article just recently at that low figure, and for the best of reasons—I couldn't get more! The supply being in excess of the demand, previous quotations cannot be expected to be maintained.

Calling on a dealer recently at the queen of watering-places here in the south, he complained that his stock of section-comb was nearly all fermenting, and being so, the article did not sell so rapidly as he had anticipated.

He could not understand it at all, the more so as the comb in the window of another retailer (who had purchased part of his consignment in bulk in the first instance) were still as pure and white as when first removed from the super. A closer inspection showed that, curiously enough, the sections (1-lb.) were with but few exceptions stacked in an inverted position; and the others in the window of retailer No. 2, which still retained their pristine purity, proved to be carefully placed right way up. And thus it is that comb is so frequently spoilt when exposed in shop-windows for sale, 1-lb. sections particularly. Honey-comb must at all times retain its original position if it is to keep well. I am induced to mention this, as I do not remember any one previously drawing attention to this somewhat important consideration.—AUTHOR OF 'BEE-KEEPING: PLAIN AND PRACTICAL,' Oct. 22.

### HONEY MARKET.

I beg to add my testimony to that of Mr. Wren with respect to the effect of a good show of honey in a shop-window. For the last three years I have dressed my window with honey as soon as I had got it bottled; and although I have doubled the quantity I had at first, I have not had enough to last the season. I have often heard the remark, 'I must have a bottle of your honey before it is all sold.' But the grocer must not be expected to take all the trouble and risk with other people's honey, if he have not already a trade for it. But if plenty of honey, nicely bottled and labelled, sufficient to dress a good window, were enrolled to a grocer, with the understanding that he was to be supplied with suitable quantities as required and settled for when sold, there are grocers who would try it; and if he got a good sale for it other grocers would want to do the same.—A VILLAGE GROCER.

### TITS AND FLYCATCHERS.

Having read with great interest Mr. Hill's article on tits and flycatchers, I should feel greatly obliged if you would invite through your columns correspondence on the subject, as the writer's experience is exactly the reverse of mine.

Part of our apiary being in a shrubbery, and there also being large woods in the neighbourhood, I have great facilities for watching the habits of the birds quoted. I may state that the great tit (*Parus major*), the blue tit (*Parus caeruleus*), and the spotted flycatcher (*Muscivora grisola*), have, during the last three years to my knowledge, bred within a few yards of some of the hives, and remain about the neighbourhood all the year round. I have only twice seen the great tit attack the bees, but the blue-tit is frequently at them; only a few days before reading Mr. Hill's article, I saw three on the alighting-board at the same time. In the years 1882-3, I counted 35 nests of the spotted flycatcher in our apiary. This year only two, one of which was directly over a hive of bees. But as yet I have never seen them attempting to catch a bee. During the last nine years, I have had occasion to dissect twenty of these last-named birds and did not find the slightest trace of a bee in any of them. Part of this was done to decide an argument which arose in a Natural History Society, of which I was at that time ornithological referee. I have often seen the house parrot take them, also the red-backed shrike (*Lanius collurio*). They will attack them, catch them, and spit them to attract other birds.

I have written to several ornithological friends inviting their experience in the matter which shall be duly forwarded. My only plea for this paper, and for asking for further light on the subject, is that I am afraid others taking Mr. Hill's word for granted will adopt the same

method, and I am too fond of our little feathered friends to see them massacred in cold blood without saying a word in their defence.—G. J. BULLER, *Weylyn*.

### THE FLYCATCHER AND SMALL TOM-TIT.

I am delighted once again to have the opportunity of rushing to the rescue of one of our many little feathered beauties—the Flycatcher. I have only shot four, to the best of my knowledge, in my life, and each time I felt as though I had wounded the heart of a friend; but I did it in the interest of science, though the post-mortems, however, revealed no traces of the bee in those pretty breasts, though I had at least twenty hives within a stone's throw of where they fell. I see you have done me the honour of quoting from a letter of mine upon the subject, and I am thankful to say that though I have made several investigations since penning those lines, 'I am of the same opinion still.' Powder and shot, alas! are cheap now, but I would give half my apiary could I have my little friends, the flycatchers, as I used to have them—*gone* indeed, but free, in the halcyon days of my Shropshire bee-keeping.

I have written to the Rev. F. O. Morris, of Nantlun-Indine, Yorkshire, whose works upon birds and almost every branch of natural history are so well known, to see if his experience agrees with my own, and, with his permission, I shall be happy to send you his reply. Meanwhile let me beg of your readers to give our little visitor a respite—but I forgot, this will not be wanted, as she already has gone to a clinic where, perhaps, her fascinating and pleasing characteristics will be better appreciated.

Appos of the tom-tit, I find I have made an entry in my bee diary; it is for Sunday, 27th January, 1884: 'I find that the tom-tits (*Parus caeruleus*) eat the dead bees.' I emptied a quantity under one hive, and find that the birds polish them immensely.'

I have not the slightest doubt but that they do attack and devour live bees when their ordinary food fails them, but then this generally must happen when bees are safe indoors. One constantly reads of the tom-tit tapping at the entrance of the hive to attract the attention of the guard bees who are turning out on duty, being instantly snatched up and taken to the nearest tree to be hung, drawn, and quartered, the tail end being a little too sharp for even the sharp little tom-tit. Now I do not say that this does not happen, but I can faithfully say I have never seen it, and this notwithstanding the fact that I have watched for hours the movements of these lovely little bunches of down and feathers.

The supposed tapping of the hive by the tom-tit to attract the notice of the bees might have originated from the fact that after having obtained a bee—perhaps a dead one—the bird invariably beats it in its beak, probably to dismember it, against some hard substance; this might happen on the alighting-board of a hive just as well as anywhere else, though far thicker away from where the insect was taken; as I have noticed that all animals of prey, birds of prey, and insects of prey, invariably carry their victim to some place of seclusion before attempting to devour it. This is such an interesting subject that I trust, Sir, it will not drop here.

ALFRED E. BOOKER HILL, *The Chase, King's Lynn*.  
[We have further letters on this interesting subject, which we hope to insert in our next number. Ed.]

### FEEDING BEES AT NIGHT.

In a recent number of the *B. B. J.* it was stated in a reply to a correspondent, that, as the nights were now cold, it would probably be found that syrup would only be taken up during the daytime. Since feeding in the daytime, especially for beginners, is rather dangerous at this season of the year unless all hives be liberally sup-

plied and no other apiaries are very near, it may be of interest to some to know how to get colonies to store the syrup at night still. The matter is simple enough. Just warm a brick and put it into the hive by the side of the combs at dusk, together with the food. The latter should be warm, though not so as to give off steam, since this would cause a deposition of moisture on the combs and inner walls of the hives—a bad beginning for the winter. Just before retiring for the night change the bricks. About as warm as the hand can well bear is the right temperature for them. Our pots come down, warm their toes, and, imagining it is summer, store several pounds of syrup. By morning all is quiet.—FRANK BENTON, *Munich, Germany.*

#### EXAMINATION OF CANDIDATES FOR THIRD-CLASS CERTIFICATES.

An impartial criticism of any event connected with the better development of bee-keeping is most desirable. From whatever source it comes, having the effect of setting wrong right, and sometimes I have noticed even going so far as to set right wrong; but save the latter.

The letter of some one, signing it 'Persevere,' hardly confines itself within the rather difficult limits of impartial criticism, and to which I must give several emphatic denials. Some of its suggestions are exceedingly good, especially Nos. 3 and 4; No. 5 I am rather doubtful of, as, in the event of a failure, it is rather 'rough on' the candidate, as such would very seldom care for every one to know his shortcomings. I should not for one, and there are many more of my opinion. 'Persevere' seems to object to the one examiner to six candidates at the Reading examination; the Rev. F. S. Sclater, who was the examiner, must be the best judge of his own capabilities, and without doubt, is so. The examinations (oral) commenced at 11 a.m. (*vide* the instructions to candidates lying before me), they finished at 2.30 p.m. with the exception of mine; I was orally examined after the practical exams. At 2.30 until 4.30 p.m. the light was at its best, the forenoon being cold, dull, and raining; I was the last but one who drove, the sunlight at my back being so powerful that I frequently had to shade the bees with my hand, to keep a better look-out for her majesty. The general public were not admitted inside the network of the tent; I saw more than one refused admission. I do not reckon Mr. Cheshire, Mr. O. Hehner, Mr. Hooker, as belonging to the general public; they were inside the net. In the 'exciting queen-hunt' I was last but two, and had plenty of light, by taking the ordinary precaution in a tent of standing with my back to the strongest light when examining a frame.

Now, 'Persevere,' how do you know that the questions of wintering capacity, measurements, &c., were not asked? I can assure you that they were, and rigorously, too; but you were not there then, as that took place in the lecture-room during the oral exams. A gentleman was asked to examine. I think three of the candidates with the frame-hive; that gentleman, I am quite confident, was capable of being an examiner (that made two examiners), it being Mr. Hooker. Mr. Sclater desiring to catch his train for a distant part. The only one who had any reason to complain of the light was the last candidate at the frame-hive, Mr. Fewtrill, but he is expert enough to catch the queen under the most disadvantageous circumstances. The oral exams, must have been most exhaustive, as they lasted in one or two instances over an hour. If these examinations are of such little utility as 'Persevere' would lead us to believe, how is it that a number of candidates fail, and chiefly at the oral exams, which I consider the most vital portion of them? The fact of the examiner standing at the back of a frame-hive surely

is no excuse for the candidate to commence manipulating standing in the front; we know there is a 'good deal' of Mr. Hooker, but he is not a mountian incapable of locomotion, he would have stood aside sharp enough if he had been asked. I should consider that a very good idea on his (Mr. H.'s) part to see whether the candidate knew how to manipulate properly, as his (Mr. H.'s) moving would have given the candidate the initiative. Every one cannot be pleased at everything, and it is only just that if any one has a grievance to ventilate, let it be ventilated, and thoroughly, too; but pray don't be afraid of the awful solemnity of seeing your own name in the pages of such a Journal as this, devoted as it is to the furtherance of one of the most useful pursuits placed in our hands by an all-wise Providence to be moulded to our needs.—WALTER B. WEBSTER, *Wokingham, Berks.*

#### HONEY COMPANY.

In answer to your invitation relative to a honey company, I say, by all means. It would be a great boon to all small bee-keepers; they do not know where to find a market for their honey, and a little ready money to them is of great moment. I have bought two swarms of bees of a poor man because he could not sell his last year's honey. Of course the price of honey will have to come down if all receive a profit. Allow me to say that if a company is formed, that the shares must be of such a value as to induce *all* who can take one or more shares; and the more it is spread about the greater the interest will be taken, and the greater consumption of honey. I have an apiary of twenty stocks, and have 'set up' six in the 'new way' of keeping bees, and I am quite sure three of these would take shares if they were, say, *1*l.** each.—W. DUCKER, *3 West Hill, Down, Beckenham, Kent.*

#### HONEY COMPANY.

Concerning the question of the proposed honey company, on which subject you invited opinions, I think such an undertaking would be a great boon to bee-keepers. Mr. Moyle, no doubt, meant well in starting his honey depot at Reading, but has evidently got out of his depth. I agreed to supply him with honey for Messrs. Huntley and Palmer at *9*d.** per lb., but the result has been the reverse of satisfactory. In answer to Mr. Lyon's advertisement, I offered half-a-ton of comb-honey in 2-lb. sections at *8*d.** per lb., but he said that 2-lb. sections were not saleable; the honey was of excellent quality. It would appear that a good year such as this is far worse for the producer than an inferior one, as honey is of little use if it cannot be turned into money, and the extra work in the preparation of supers, &c., is a great consideration.

The principal dealer in Brighton has given up that branch of his trade as giving too much trouble, and another at Bognor has become a bee-keeper himself, and so supplies his requirements, so that my takings up to this time have not exceeded 3 pounds. I should think that most bee-keepers of any standing would be glad to become shareholders or subscribe a yearly amount, if there was a chance of a *bona fide* sale. Perhaps if a depot were started in London, and agents procured in provincial towns, something might be done, no doubt. No doubt lots of tradesmen would undertake sales on commission, although not caring to risk their money in buying on their own account.

I see that you state in a late number that in your opinion honey is of nearly double value to sugar syrup for feeding bees, if so there is not much profit in carrying on extracting and leaving the hives very light in the autumn, as most of my neighbours do, for if comb-honey will not fetch *8*d.** per lb., the market value of extracted honey must be very low indeed.—L.B.G.O.



## WINTER PACKING.

A singular disaster, resulting in the loss of a fine strong stock of bees, has befallen a level-crossing keeper on the railway here. This is his first year with the bar-frame hive. In the spring he had three skeps, but by swarming and transfer had got his bees into six bar-frame hives of his own make. He had packed them up for the winter—strong in bees and stores,—and was just congratulating himself that they were all comfortable, when lo! yesterday morning (the 17th) on rising, he found his bees in a highly excited state as early as 6 a.m. Next thing, he finds honey running out of the entrance of one hive, and upon looking in, he, to his great dismay, found all seven combs broken down, and nearly all the bees, including the queen, smothered in honey. It was too late when I arrived there some four hours later to do anything to save the brood, of which there were good patches on four frames, as it was hopelessly chilled. So there was nothing to do but to ascertain the probable cause of the disaster. In packing for the winter, he had set the frames to the back of the hive, with a chaff-packed dummy in front, having  $1 \times \frac{3}{4}$  inch entrance cut quite to one side. On the top of the frames was a quilt, with a chaff-box, covering the whole of the hive on the top of that. He had also cut two large winter passages through the combs, one on each side, which, of course, must have weakened the combs to some extent. The night had been close and warm. The hives all stand within about four yards of the railway, and the jar occasioned by passing trains shakes them almost as bad as an earthquake would, but the bees do not seem to object to that at all. The cause of breakdown may therefore be readily surmised. The bees were too hot; the weakened combs had become very soft, and then, no doubt, the jar of the heavy goods-train, which passes about 3 a.m., caused them to part at the winter passages, and down they went. It must, I think, have been the jar of a train, as it can hardly be supposed that the temperature of the hive, although, doubtless, very high, had risen higher than that of a strong stock exposed to the rays of a July sun such as we have had this year. I have advised him to shift all his bees to the other side of the garden, away from the shake of the trains, or, probably, this will not be his only breakdown.

I doubt if the half-inch entrance to the inside-front dummy, as recommended in 'Useful Hints,' is sufficient to ventilate a strong stock of bees. It is a very different thing to a half-inch outside entrance, when the frames are close up to it. Cool air can then readily enter. At any rate, it is quite clear bees may be packed up too much at this time of the year, especially when they are working vigorously upon the ivy, as in this case. I looked through his stocks a few days before and found them all crowded with bees, and all having large quantities of worker brood. In one hive I noticed a small patch of drone brood also. None of the hives were queenless, but there were young drones in each hive. Is it not very unusual for drones to be tolerated and raised so late in the season?

I feel very sorry that he has met with such a mishap, still, as he is a persevering and enterprising man, he will get over it, and will probably become a successful bee-keeper. — H. T. SNOOK, *Wesham, near Hastings.*

## QUEENS BY POST. BEES FROM CYPRUS AND SYRIA.

British bee-keepers will be pleased to learn that Mr. Frank Benton has at last after ten years' experimenting, he says, made a complete success of sending queens in the mail-bags. Perhaps no one in this country understands the difficulties he has had to contend with better than myself, and these are only what have come under

my own observations, one difficulty being the postal regulation excluding bees from the mails. This to most people would seem insurmountable; so with every change of post-master, a deputation from the British Bee-keepers' Association have waited on him, requesting bees to be allowed to pass, with always a negative result; and for why? Because 38 Vic. chap. 22, sec. 4, forbids the Postmaster-General to carry *live animals* through the post, therefore, as bees are animals, no matter who might be the postmaster (even Mr. Cowan) an Act of Parliament would be required to give him the power to carry them. The realisation of this fact with most people would cause them at once to give the matter up as an impossibility; but not so Mr. Benton, for though, perhaps, he is not an English lawyer, he probably has heard that a coach and four can be driven through any Act of Parliament; and if one gets hold of a *Postal Guide*, and considers the number of 'Acts' that have been passed, it would be hard not to find some clause under which bees can be transmitted, and this is accomplished by simply *registering* them; so now, when we leave the post-office with the receipt in our hands, we are certain they will be delivered. Thus by the 'Benton' cage, and register letter-post, a queen may be sent anywhere under twenty-four days' journey; the parcel-post does not carry bees, as 'live animals' are still excluded from it.

So what all British bee-keepers have ardently wished for has now been given them by Mr. Benton, and a queen can now be sent to any part of Great Britain for *3d.*, or to any part of Europe and America in a cage, partly designed by myself, for *5d.*\* Contrast this with *1l. 12s. 6d.* I paid for carriage alone from Trieste on four dead Cyprian queens in October, 1881, all in one parcel.

There is another difficulty he has not been able to surmount yet, viz., getting Cyprian and Syrian queens in quantity during summer, for some people will wait until they have a stock to divide before they think of ordering a queen—to supply the demands for them, as some readers of the *Journal* very well know. Whilst he was in the East, of course we had no difficulty to get them, but he soon found he could not stand the climate in summer-time, which carried off his only child. He therefore made arrangements with Mr. Balden-penzer (one of his pupils) to take the charge of his apiaries and furnish him with a constant supply of these queens; and as this gentleman was born and brought up in Palestine, he naturally thought he could stand the climate further north, but he, too, fell a victim, and 'be-vented' home again, and will not go back on any account. So last winter Mr. Benton had another journey, and made what he thought favourable arrangements to keep up a regular supply, but as soon as he had gone home, all the contracts and undertakings were (Oriental like) treated as nothing. Thus, he says, he will have to go to the East very winter, rear queens in the spring to supply orders, and send them direct from Cyprus and Syria to the people who want them, returning home before the weather gets too hot. Thus, it will be seen that these

\* This is not quite correct. We have received from Mr. Frank Benton a communication to the following effect:

'After much correspondence with German and Austrian postal officials, I secured the adoption of a regulation admitting bees to the mails, but the best I could do was to get them admitted at letter-rates: *20pf.* for every 15 grammes or fractional part thereof *2½d.* for *1 oz.* The boxes go *double* for each queen going outside of Germany and Austria, and so costs *5d.*, and to this, registration fee if the packet be addressed to France or to England; or altogether *7½d.* on each queen to the countries. For America more food must be put in, hence *three* rates have to be paid *via* Havre and *via* Bremen, or *7½d.* If addressed *via* London or *via* Queenstown, registration is necessary, and thus *10d.* per queen is the cost. Within Germany and Austria *20pf.* = *10d.*, = *2½d.* pays for any weight up to 250 grammes.'

queens will have to be ordered in the winter to make sure of getting them, and that for a long time to come the prices are not likely to be lowered. He is very anxious to be able to keep up a regular summer supply, which, he says, he could do by taking out European help and securing the spring harvest of honey (which is both good in quantity and quality), but to do this properly, with a sufficient number of hives and imported help—so as to be entirely independent of natives—he requires more capital than he has at disposal, so he has made me an offer if I will find it, but as I do not care to make any profit in this matter, and I consider it one of general interest to bee-keepers, I think others as well as myself should share the honours of helping to keep up a supply of the best bees which have been found—one queen of which has been known to fill a 10-frame Lang-truth hive with bees (equal to sixty Association frames), and the bees stored 1000 lbs. of honey.

I have been keeping Syrians three seasons, and I am satisfied nothing has been introduced to bee-keepers of such benefit since the bar-frame hive as these bees, and Mr. Benton, conscious of their great superiority, and after passing through all his trials and privations to give us these bees, says, 'I do not want to quit supplying real Syrians and Cyprians until these races shall have taken the position they merit before the bee-keeping public.'

Shall America claim all the honour in giving us these bees, or is British capital to take a share? Those who are willing to confer a benefit on advanced bee-culture, and at the same time benefit themselves, can contribute to the Syndicate, should address me as below for particulars, stating the amount they can find, and enclosing stamped and directed envelope?

Least any should think I am privately interested in these Eastern bees, or the work of Mr. Benton, I will give my word, without the slightest fear of contradiction from any one, that I have never had any trade dealings in these bees, never selling one at a profit or brooding any for sale; nor do I intend to breed any while the supply is maintained. Also I have always paid full price for every queen sent me in good order.

I make the above statements because, judging from some of the letters sent me, people seem to think I was selling Syrian bees and was praising them as a kind of advertisement; such is not the case. I have written in their favour as I find them, because I think they will benefit bee-keepers; and I make it a rule to never make any charge or money profit for any advice or assistance in bee matters, no matter who the recipient may be. I now have something good in many ways to offer to such as care to accept it.—JOHN HEWITT, *Sheffield*.

#### GLAMORGANSHIRE BEE-KEEPERS' ASSOCIATION.

What has become of the newly-formed Glamorgan-shire B. K. A.? I was in hopes that something would have been done in this neighbourhood before this to extend the Association, but so far as I am aware nothing has been heard of it in Cardiff. The Hon. Sec., I believe, lives near Swansea, which is forty miles from here, and so far as that place is the centre it might, to us cottagers, be as well in the Soudan. To attend a meeting there means 8s. railway fare and the loss of a day's work, and to us who work from 6 a.m. to 6 p.m. this is a considerable sum. Surely there are some gentlemen in Cardiff sufficiently interested in bee-keeping to make an effort to establish a branch that may put us cottagers in the right path. I am well acquainted with one bee-keeping friend who is thoroughly competent and willing to act as expert should a branch be formed in the neighbourhood. Hoping some of the local gentry interested in bee-keeping will take the matter up without delay.—EDWARD GIBBONS, *Teig Cottage, Llandaff, Cardiff*.

#### HONEY FROM A COMMERCIAL POINT OF VIEW.

Until recent years bee-keeping has been simply a hobby in the hands of amateurs, who had only a few pounds of honey to dispose of, which was generally taken by friends and neighbours at high prices as something choice. But now the vast strides which the industry is making have altered the aspect of affairs altogether. Not only are many former purchasers now themselves producers, but the product is many times what it was. The limited outlet at high prices no longer exists; but bee-keepers as a class have not yet grasped the fact, and still cling to the tradition of 1s. 6d. per pound. As English honey continues to be produced in larger quantities, so will the price have to come down until it only exceeds that of foreign according as the quality is superior. A great outcry is made that there is no market for English honey; but the market exists if it could only be supplied at the market price. The question arises, how is the honey produced to be placed in the hands of the consumers?

Producers have three classes of buyers open to them. First, friends who will take small quantities at retail prices. Second, shopkeepers who will buy larger quantities at such prices as will enable them to supply their customers at a fair profit, at such a price as will tempt them to buy English instead of what they are buying. Third, wholesale dealers who will undertake to receive larger quantities and distribute to the shopkeepers, taking the trouble to receive and bottle run honey, glaze sections, obtain orders, deliver, and all other details. All these expenses having to be borne out of the difference between the price they can buy at and the price the shopkeepers will pay.

From the first class high prices may be obtained. From the second, lower prices for larger quantities, but then to reach this class of buyers the bee-keeper must turn commercial traveller, and offer his honey to the shopkeepers. This is being done to a certain extent. I hear of bee-keepers on tricycles offering and selling honey in London. But there are many to whom this plan would be distasteful. Picture to yourself the grave and reverend pillars of the B. B. K. A. careering about on wheels and dismounting at grocers' shops to sell honey! Here comes the third class of buyers, who will take all the trouble upon themselves, and make a profit out of it, requiring a still further reduction in price.

Now the mistake which is being made by would-be sellers of honey is to expect from the third class of buyer the prices obtained from the first. This is a quotation from a letter offering honey to me (as one of the third class of buyers): 'I have sold some of my honey at 1s. 3d. per lb., but have about 3 cwt. to spare, if you can take it at that price,' &c. And this with variations represents scores and scores of letters. When I mention that I saw in a grocer's shop in Brighton a window full of 1-lb. sections at 10d. each, and that in London some grocers have bought from tricycles at such a price that they are selling sections at 1s. each, I need hardly point out the absurdity of such offers. Then as to extracted honey, when sections are offered retail at 1s. each, how can seller expect to get 9d. or 10d. per pound in bulk? Bottles cost 18s. per gross, and there are the expenses of bottling, cost of covering, labelling, breakage, waste, labour, carriage, traveller's commission, and other expenses to be met, and the filled bottles to be sold at not more than 10s. per dozen. Grocers will not push the sale of English honey at a small profit to the exclusion of foreign, which pleases their customers, and on which they get more profit without pushing or trouble.

And now for a response to your invitation for opinion as to the proposed Company. I have had some little experience of companies and have been behind the scenes of promotion thereof. In nine cases out of ten the

object of companies is, *inter alia*, to provide a good berth for some one who desires to be manager; then there is a secretary, who generally provides the preliminary expense and receives a good salary. Directors will be required, and they will require fees, and rightly, they cannot be expected to give their time gratuitously any more than the manager. Rent of premises, and other expenses too many to catalogue here must be met; and all this will be found to amount to a total which will absorb the profit upon a good deal of honey; and, moreover, these expenses will recur every year, while such a honey yield as that of 1884 does not by any means recur every year. Out of what fund are the expenses to be met and dividends to be paid when little or no honey is to be had? There will be a temptation to be dabbling in other matters besides the sale of honey; perhaps in making hives and appliances, perhaps in establishing a bee-farm, and for these purposes more capital will be required, preference shares and debentures will be created. But where the dividends are to come from is another question. All the honey which is produced, or likely to be produced, can be sold through existing channels. There are many houses who have already business with growers and other sellers of honey, who could and would take up honey in those years when there was a surplus, with no extra expense, relinquishing it in those years when the crop was short; and no company with fixed expenses to be met out of honey alone, whether there was much or little, could compete with them. Neither a company nor any private firm can help bee-keepers to obtain a higher price than the honey can be sold for. As I said above, the market is already in existence. What is wanted is a commercial common sense among bee-keepers.—E. LYON.

#### JUDGES AND OFFICIALS.

The letter in your issue of 1st of October from 'The Station-master' brings to the front a question of great importance. As an exhibitor, I cordially agree with him that some rule should be adopted for the guidance of exhibitors, and, may I add, judges. At an exhibition this season where I was an exhibitor, the decision of the judges in some of the classes were utterly incomprehensible to practical bee-keepers.

Another matter which deserves attention is the conduct of officials appointed to sell exhibitors' honey. The following occurred at this same show. An exhibitor, on going the morning after the show to remove his unsold honey, found it all on-odd, but before removing it one of the officials appointed to sell made him an offer for part of it, which he accepted, and in the course of five minutes he was smilingly told by the buyer that he had sold it at a profit of three pence per lb., which, of course, went into his own pocket. The remarkable thing here seems to be that this official could not sell any of this exhibitor's honey until it became his own, he then had no apparent trouble in disposing of it to his own advantage. Conduct of this kind is very harmful to the purity of societies, as members treated in this manner derive no benefit from their membership, and cannot be blamed if they withdraw from such company.—APRILIST.

#### BEE-KEEPING ADVANCING. A MARKET FOR HONEY.—PRICE OF HONEY.

There is not a shadow of doubt that bee-keeping on the improved humane principle is making very rapid strides amongst cottagers. Should there be any one who doubts this, let him take a walk through four or five villages in any county where there is a Bee-keepers' Association actively at work; and if he use his eyes he may count as many as twenty, aye, forty, bar-frame hives in cottagers' gardens, where three or four years ago there was not one to be seen. Now all this must be

very gratifying to the B. B. K. A. It is one point of the 'rosy picture,' so to speak, gained, and which the B. B. K. A. started to attain.

But what about the other point in this rosy picture?—the most rosy to the cottager, seeing that it is held out to him as his reward for mending his ways in bee-keeping. Here it is—'No inconsiderable profit.' Is this point gained, being gained, or likely to be gained? Well, the outlook at present is not reassuring. 'Honey, abundance of honey everywhere, and no market for it' is the cry on every hand. It is to be sincerely hoped that a company or companies will be speedily started to buy up and open a market for this plethora of British honey. If your cottager is anything, he is shrewdly practical, and just now he may be heard disengaging and weighing in his own mind the pros and cons of bee-keeping. I heard one exclaim the other day, 'These new-fangled hives cost heaps of money, give lots of trouble, and now I have got plenty of honey I can't sell it. The old skeps cost me at most only 1s. 4d. each, gave me no trouble, and I could always sell my honey at 6d. per lb.' Let us hope a profitable market may soon be found for the cottagers' honey, his failing hopes in bee-keeping revived, and confidence in his bar-frame hives restored.

Like 'Plat-layer,' I hope the Honey Company about to be formed may see its way to issue shares sufficiently low for cottagers to take up, and to participate in the profits. In any way, it is to be hoped the Company will be satisfied with as small a percentage as will be compatible with its safe working, and not allow itself to drift into one of those middle-men concerns, which swallow all the profits, and are doing more to ruin all the producers of the fruits of the soil in this country than any foreign competition. —A HONEY COTTAGER.

#### FIXING COMB-FOUNDATION.

I have often seen inquiries about fixing comb-foundation. The simplest way I know of is by placing two boards in bench, or board, about two inches apart, placing the slit of bar in bars, twisting round, then place your foundation between your two hands and drop it in; it will then have itself tight; first bite the corners off. —A. CLAYTON, Welling.

#### LANCASHIRE AND CHESHIRE BEE-KEEPERS' ASSOCIATION.

A letter in your issue of the 1st ult., signed 'Thota,' asks why the L. and C. B. K. A. is doing in the Chester district, and complains of neglect of my stewardship. I might well say, 'This is the unkindest cut of all, and I ask space for a few words to show how much truth and justice there is in that part of his letter which relates to myself. A copy of the enclosed poster, framed and glazed, has, for the past two years, been fixed in a prominent position on the front of my business premises, so that all who pass may read of the L. and C. B. K. A., and the advantages it offers to bee-keepers. The result has been a considerable addition of members. During the last summer I have had interviews and corresponded with not less than eighty-three bee-keepers, all belonging to my own district. Indeed, I found the time required for bee matters interfere with my business so much that I requested our Committee to appoint an assistant local secretary. They have not done so, but instead have allowed me the services of the 'expert' whenever I required him. If 'Thota' had visited our establishment on several market-days this summer, he would have seen as many as five or six bee-keepers at a time waiting for advice and assistance from me, which I am always glad to give either verbally or by letter. When I first

This is a most effective poster.—Ed.

heard of the L. and C. B. K. A., I sent in my name and subscription, at the same time offering my services as Local Secretary, believing that I could induce other bee-keepers to become members, and by obtaining a voice on the committee, secure to ourselves the advantages of the Association. I am glad to say my efforts have not been in vain; bee-keepers are now coming to me and paying their subscriptions without my looking them up, and other members are also bringing in recruits. One clergyman writes to me thus,—‘Four more converts (from destroying their bees) at Guilden Sutton, who wish you to call upon them, and they will pay their subscriptions to you.’ Two days later the same gentleman writes, ‘A lady wishes me to give you her name as a member; call and see her and take the expert with you.’ He also brought me the names of two other gentlemen on the same day, together with their subscriptions; so that makes seven members through this gentleman alone. I could give many other instances showing how we are getting on and what we are doing, but will not trespass on your space.

Touching Theta’s drive to the Duke of Westminster’s estate and the prevailing ignorance regarding the Bee Association there, is your correspondent aware that his ‘Grace’ is President of the very ‘Independent Association’ you call attention to in your *Editorial Notes*? So if its existence is unknown on the estate of its own President who is to blame? As to the L. and C. B. K. A., I am proud to say, we have about fifteen members, including three clergymen, in the very district mentioned. The reverend gentleman spoken of by Theta does not often visit our ‘Ancient City,’ or read the local papers, or he could hardly be unaware of what is being done by the L. and C. B. K. A. in our midst.

Speaking for myself, I may say it is not by sitting at home writing articles and finding fault with other people that you are likely to get the advantage and assistance you require. Theta has reminded me all through his article of the forcible saying, ‘Willing horses may work;’ and he does not seem content with this, but, like some young inexperienced wagoner with a new whip, must use it upon one or more of the ‘Willing horses’ he chances to come across.—WILLIAM E. LITTLE, *Eastgate Row, Chester.*

**BEES IN THE ROOF OF A CHURCH.**—A very interesting discovery has been made in the parish church of Stourmouth, near Wingham, Kent, a hive of bees being found in the roof of the chancel, a somewhat romantic history being attached to them. The existence of the hive was known to the church officials, but no idea seems to have been formed as to its actual extent. The living has been held for many years by the Rev. Mr. Drake. Some time ago it came to his knowledge that a swarm of bees had settled in the roof of the chancel, but he would never allow the sanctity of their retreat to be disturbed. A few months ago, however, the vicar died, and the church has been undergoing general repairs, and the bees, no longer destined to remain in possession of their quarters, were destroyed by fumigation. On the honey being taken there was found to be nearly two hundred-weight of it, and the bees filled two moderately large barrels. It is stated that during hot weather the honey used to drop down into the church.

**INTRODUCING QUEENS.**—I will detail in as few words as I can the methods that I have employed the last five years without a failure. Having procured the queens to introduce, I keep them in as comfortable a place as I can till evening. In the afternoon I hunt out the queens to be superseded, cage and return them to the central part of their respective brood-nests. At or after sundown, I remove them, spray the bee and brood-combs liberally with diluted honey or thin sugar syrup. Daub the wings of the strange queen by turning her over in a spoonful of

honey taken warm from one of the combs of the hive in which each respective queen is to be introduced, and introduce by allowing her to crawl among the workers on the brood-comb. Watch the workers a moment, and if there are any demonstrations of anger, spray bees and queen till they let her alone. Close the hive and all is done. If it is desired to introduce to divisions, it should be done as late in the day as convenient, and be sure that we know where the old queen is, ascertaining to a certainty in which division she is. The philosophy of the above method seems to me to be in the bees never for a moment missing their queen. Aside from a little disturbance and a liberal feed, the bees seem unaware of anything unusual. Under this method of treatment, workers never molest or commence to hunt a queen, and never ball one after dusk and before sunup, and before they have forgotten their general feed, she is perfectly at home with them and is laying.—D. KEPLER, *American Bee Journal.*

**MAKING HONEY VINEGAR.**—The cappings shaved off in the preparation of honey for extracting, are always allowed to drain. But even when thoroughly drained, considerable honey still adheres to them, and it is an excellent plan to have a keg or barrel of water in which to wash them, and to allow the water to ferment and become vinegar. Water which has been used to rinse out any utensil that has contained honey, can be thrown into the barrel. The scum that arises upon the surface of the sweetened water should be skimmed off.—*American Agriculturalist.*

## Review.

**THE HONEY BEE: its Nature, Homes, and Products,** by W. H. HARRIS, B.A., B.Sc., is a recent publication of the Religious Tract Society, and is fairly up to the times as regards the modern appliances of bee-culture and the rapid strides made in the art in this country during the last five or six years, under the fostering care of the British Bee-keepers’ Association. We are pleased to see that the Society has superseded the *Hive and its Wonders* by the publication of a volume so much its superior in every respect. The author Mr. Harris is not only a successful bee-keeper of the modern type, but is able to express his ideas in a style so interesting that few who take up the volume will be able to lay it aside before having waded through its contents.\* Its illustrations—eighty-two in number—are, with few exceptions, well executed, and, generally speaking, such as will prove useful to the tyro in the science. The obsolete ‘Nutt’s Collateral,’ although with others forming a pretty group,

\* The volume, however, is not free from faults. On page 16 we find it asserted that ‘the young bees issue forth, in search of stores, at the age of two or three days,’ whereas it is a well-established fact that during the first two or three weeks they remain at home performing the office of nurses to their newly-hatched sisters. We also find brood-cells, or brood-nest, spoken of as ‘hatching places’—slight errors in fact, or diction, which the author will do well to correct in a future edition. There is also, in the chapter on ‘Diseases,’ a slight confusion on the subject of Foul-brood, which appears to be taken from Dr. Dzierzon’s treatise, and which is evidently confounded with ‘chilled brood.’ Salicylic acid, which has proved efficacious in many instances, and is well known as a powerful antiseptic, is spoken of somewhat slightly. The author borrows freely from most of the more celebrated writers on the science, but has entirely omitted any mention of the introduction of the Eastern races of bees—Palestine, Syrian, Cyprian, and Italian—into this and other countries, and which we consider a serious omission in any treatise on modern apiculture. An index, of which it is at present minus, would add considerably to the value of the book.

can hardly be termed a 'Modern Hive,' its principle having long been discarded by all apianians of any note. The book contains 272 pp. and is divided into twenty-eight chapters, of which we would specify, Chapters—I. 'Historic Sketch' (tracing the subject as far back as the Scriptures, Vedas, Egyptian monuments, Koran), &c. II. 'Natural History,' in which the four development-stages—*egg*, larva, pupa, and imago—are well given. XI. 'The Physiology,' XIII. 'Thorax,' XIV. 'Abdomen,' and XV. 'Diseases of Bees,' wherein Mr. Cheshire's late discoveries are described with eulogy,—are more particularly worthy of commendation, and should be carefully read and digested by all students of apiculture, more particularly by candidates for the High Class Certificates of Experts awarded after examination, by the B. B. K. A. The book is nicely got up, the type and paper good, and it may well adorn the drawing-room tables of all who are interested in the pursuit. We are afraid, however, that its price, 5s., will exclude it from the homes of the cottagers—the class in which we are all more particularly interested. We could wish that the old Society for Promoting Christian Knowledge would follow the lead set by its contemporary, and give to its supporters and *alumni* the benefit of a volume of equal merit and scope at a price more within the means of the cottage class. Although we have spoken somewhat highly of the merits of this publication, we do not anticipate that it will ever take the place of that excellent practical work—the text-book of all practical bee-keepers, the *British Bee-keepers' Guide-book*, by T. W. Cowan, Esq. Nevertheless it is a decidedly useful addition to our bee-literature, and as such we give it a hearty welcome and wish it every success.

## Echoes from the Hives.

*Hunsdon, Weston, Ross, Hereford, 20th October.*—Last April my host left his residence, Southwick Park, near Tewkesbury, for this place, twenty-two miles off. Mr. Hole, the expert for Herefordshire, went to Southwick Park, but by accident only reached there late in the evening, 8 p.m. He managed to pack for travelling three Abbott's Standards, one Abbott's Combination hive, and one straw skep. These were sent off in a light cart at midnight, and got here in good time in the morning. They were set down under a high wall facing east. This house being under repair all the summer they were left to shift for themselves, and, so far as I can learn, they threw off many swarms to the benefit, I hope, of the villagers. To-day Mr. Hole came over to inspect as county expert and settle the hives for the winter. To the credit of his careful packing under difficulties all had travelled well. One (a makeshift) had quite recently lost its bees, probably from having been moved by masons, who were building a wall, and the hive was in their way (I charitably wish they had been badly stung), but the combs were full of stores. The others were full, and we took comb and honey estimated to weigh 60 lbs. to 75 lbs., leaving three hives to winter with very ample stores. The straw skep was united to the Combination hive. If these hives had received reasonable attention they must have produced from 150 to 200 lbs. So much for this little apiary. I have one Combination hive in Kensington; from it I have taken about 15 lbs. It, like these, was quite neglected. I ought to add that Mr. Hole was most attentive, and showed himself really an 'expert,' and, I hope, converted two persons present to becoming interested in bee-keeping. The value of such an expert as Mr. Hole making a circuit is immense.—J. W. HAWKINS.

*Thickthorn House, Norwich, October 22nd.* *Ivy Honey.*—In my neighbourhood there is a large quantity of ivy. This year it has produced a considerable

amount of honey and pollen, and my bees have been very busy on it for the last month. I notice that after a chilly, cloudless night very little honey is secreted, but a still, warm, cloudy night produces enough for my bees to collect and to keep them busy all day. The honey gathered from the ivy flowers has a most disagreeable taste. It also quickly granulates into pure white crystals. During a spell of a few days' cold weather I found a quantity of unsealed ivy honey granulated in my hives. The abundance of this sort of honey this autumn has been of great assistance to me, for I have had no occasion to feed, and the steady income has stimulated the queen to brood quite vigorously. It gratified me much to see phenol recommended to prevent unsold honey from fermenting. I intend to take advantage of this item of good news. Wasps have been unusually numerous this year; I have destroyed thirty-eight wasp-nests within a radius of 200 yards. A skipper near here has had one of his hives destroyed by hornets—young bees, brood, and honey were all cleared out in an incredibly short time. I have had a peculiar instance of robbing lately. The bees from one stock of a neighbouring apiary were permitted access gratis to a strong stock (strong in bees and honey) in one of my bar-framed hives, and in one day and part of next almost cleared out all the stores. I contracted the entrance and crowded the bees on to four frames, but it was all to no use, the robbers and robbed seemed to be mutual friends, and to have one common interest, in re-victualling the hive, and that too with enterprising zeal. I was finally induced to adopt very stringent measures against my determined opponents, the robbers I closed the entrance for two days, at the same time providing ample ventilation; although there must have been numbers of robbers in the hive, I only found some half-dozen dead on opening it again, but by this means I restored order and good conduct once more. The robbed colony were strong in bees, brood, and possessed a prolific queen, too. Can any reader suggest the reason of this irregularity?—H. DONNAN.

*North Leicestershire, Oct. 26th.*—To-day the bees have received a check; the weather is too cold and stormy for them to venture out; but up to date, with one day's exception, they have been working continuously on the ivy for five weeks. On all hands there are reports of the bees carrying in abundance of pollen, and in some cases a considerable increase of stores is reported. Michaelmas daisy has been very attractive to the bees, and so have single dahlias.—E. B.

*Langholm, Dumfriesshire.* Our honey show proved a great success. The tent was beautifully decorated with hot-house plants, both inside and out, and was made as attractive as possible. It had the desired result of drawing crowds of visitors, our Patroness the Duchess of Buccleuch along with the Duke and party, favoured us with a visit, the Duchess in particular making interesting inquiries about the various exhibits. We had also two very creditable exhibits of bee and honey appliances, a great amount of honey exhibited was sold at the following prices, honey in super, 1 lb. or 1½ boxes, 1s. 6d. per lb., honey in straw supers from 6 to 12 lbs. 1s. per lb., dropped honey in 1 lb. glass jars 10d. to 1s. per lb. Most of the honey in this district is now sold. The demand has been good especially for heather honey, and it is nearly all heather honey we get here. The weather is now cold, and most of the hives are condensed and packed for winter.—H. SANDERS.

**DIRECT QUEEN INTRODUCTION.** T. Haywood (*New Mills House, Ledbury, Oct. 18th*) writes: 'No one could have felt more bitter against Mr. Simmins than myself on first trying to introduce an Italian queen to a black stock after reading his *modus operandi*, but with one exception it is the only failure I have had, and last season and this I have introduced

scores and under all circumstances; and I think with 'H. T. Spice,' that those who have derived any benefit from the 'Simmins' method should, in justice to him as well as for the good of bee-keepers generally, make known their success or otherwise. Your correspondents, 'H. T. Spice,' 'Humble Bee,' 'E. H. Bellairs,' and 'H. O. Smith,' I fully endorse, and expect many more bee-keepers can do the same.

B. Christian (*Baldock, Herts, October 23*) writes:—I have arrived at quite an opposite opinion from Mr. Raynor regarding the direct utility and feasibility of direct introduction as practised by Mr. Simmins, as I have scarcely ever failed, but have been so successful, that I have not had the slightest hesitation in so introducing the last three Ligurian queens I have purchased, all of which were successful. I should certainly not have risked the loss of three valuable queens had I been in any doubt as to their reception. I have very carefully noticed the various conditions under which I have been working when introducing, and find the queens are far more readily accepted in spring than in late autumn, in fact I have never had a failure in the spring. In the autumn it is very difficult, and with a queenless stock almost impossible. I think the two principal reasons why failures occur are, first, the use of too much smoke and rough handling, causing great excitement; secondly, leaving the queens too long in mesh. I find the younger bees are in the nucleus the more readily are they accepted.

## NOTICES TO CORRESPONDENTS & INQUIRERS.

**INQUIRER.**—*Queen Mating.*—The only method with which we are acquainted of procuring the fertilisation of queens by selected drones, is that named the 'Kohler process,' and which is fully described in the pamphlet on 'Queen Introduction,' by Rev. G. Raynor, and sold by Mr. Huddle. The method is shortly described thus:—As soon as a young queen is hatched out in a nucleus-box, a number of drones of the selected race, are confined with her in the box until she is of age sufficient for making her aerial trip. Then, on the afternoon of a fine day, when other drones have gone to rest, the nucleus-box is opened, and the queen and her companions, stimulated by previous feeding, immediately avail themselves of their liberty, and fertilisation is accomplished.

J. M. S.—*Salicylic Acid and Therax.* Salicylic acid is powerfully antiseptic, hence we deem it useful when given in syrup food as a *preventive* of germ diseases of any kind, and conducive to the health of colonies, independently of the use of phenol as a *cure* when the disease has been contracted.

E. L. H.—The piece of comb forwarded has been subject to the ravages of the wax-moth. It is not affected with bacillus.

A. DONNELLY AND Co.—The top bar of the standard frame of the Association is seventeen inches in length. It would be difficult to say what sizes of sections are likely to be in demand next year. But 4½ by 4½ for 1 lb., and 5½ by 6½ for 2 lbs. have proved serviceable in the past.

W. SCOTT.—*Giotto Frames.*—Pastor Ulvi Giotto introduced the special hives in which these frames are used. They were called after his name.

W. BROWN, *Selkirk.*—*Young Queens cast out of straw hives.*—We fear that your suggestion is correct that the old queen has died or been superseded and young queens raised. Consequently you will have an unfertilised queen. You may drive and find her and requeen or mate. Your case shows the evil of fixed combs. How easy it would be to satisfy yourself of the state of affairs had you a bar-frame hive.

ESQUIRE, *Co. Down.*—I, *Queen minus a Foot.*—If she

has been prolific hitherto it is clear her loss does not affect her as a mother, and we should retain her, uniting queens at this season is risky, and in case of failure you have a queenless stock to deal with. 2. *Cattle in Field with Hives.*—By all means retain your piling; prevention of a hive being upset is better than cure. 3. *Best Hive for Extracted Honey.*—The doubling system will give you the best results. You have a double lot of bees to gather it and tough combs for extracting.

F. MEK.—1. *Washing Quilts.*—The cost of a clean new piece of ticking is only about 2d. or 3d., and it is not worth while to wash them. If you have some very much propolised, Mr. Helmer would be glad of the propolis, as stated in our last number. If you are bent upon washing them, soak in methylated spirit first to remove the propolis, and then wash. 2. *Centrifugal sugar* is a kind of crystal, and good for syrup making. The refined crytallised sugar may be procured from Messrs. Neighbour, Regent Street. 3. *Wax-moth.*—The deductions you draw from your microscopical observations are not correct. There is no doubt that the sinosities in the comb are the result of wax-moth.

THOMAS VALLEY.—1. *Surplus Combs.*—Keep them, and when enlarging the hives in spring, uncap the honey and give the combs back to be cleared out as food. 2. *Combs and Foundation.*—You are wrong in your reasoning. Foundation is not suitable for enlarging the brood-nest in spring. Give ready built combs by all means.

J. NAINBY.—*Unfinished Sections.*—By the time they are wanted the honey will have granulated, and must be cleared out by the bees before fit to fill. You had better extract now and keep the combs carefully. They will become to some extent discoloured, and not so good as freshly built ones.

H. MUSTYS.—1. *Painting Hives.*—The best time for painting hives is in spring; then the winter packing may be removed, and the frames and bees be transferred to clean, and newly painted hives. 2. *Covering for Winter.* See 'Useful Hints.'

T. WARD.—*Sugar.*—The sample of sugar forwarded is what is termed 'stitch pieces.' The saccharine properties are much affected by the mode of its manufacture. We do not recommend its use for making syrup.

T. B. G.—*Queen Introduction.*—Introducing stranger queens at this late season, is more difficult than at any other time, especially if brood exists in the hive from which queen-cells can be raised. You did wrong in leaving the queen encased, which was certain death. Perseverance in cutting out cells would have ended in success, since when the larvae were too far advanced to form queens, the bees would have accepted the stranger. You do not mention what cage you used, but before each attempt at liberation you should have noticed carefully the animus of the bees upon the cage. If encasing it in a closely formed knot, with curving bodies, and an angry hissing hum, the liberation should not have been attempted. As it was you should have again caged the queen when the bees attacked her. At each examination the queen-cells, however rudimentary, should have been destroyed. Bees will never receive a stranger queen while they are in possession of the cells which they have raised after discovering the loss of their former queen. When brood exists in the hive, many skilled apiarists remove the old queen several days before introducing the new one, thus allowing queen-cells to be formed, and the hopes of the bees destroyed before the attempt at introduction is made—a good plan at this late period of the year.

Several other queries have been received, but too late for insertion: replies will be forwarded.



to the decision of the judges and heartily to congratulate the recipients on the results.

We note that to the British Bee-keepers' Association have been awarded two Diplomas of Honour. The first, we presume, is due to the position the B. B. K. A. has taken with regard to the Show; on it has devolved all the anxiety and responsibility of the Department, and the conduct of it from first to last has been under its direction. It also may be considered as a recognition of the two very admirable lectures which were delivered by F. R. Cheshire, Esq., and Otto Hehner, Esq., under its auspices; and of the services it has rendered in the development of bee-keeping as a national industry and the introduction of honey as an article of pure food. The second, perhaps, has been granted for the publications, literature, and diagrams which have been exhibited by the Association.

Messrs. Neighbour and Sons have received a silver and a bronze medal for their exhibits of honey and hive appliances under Classes 1 and 3.

To Mr. S. J. Baldwin has been awarded a bronze medal for his well-assorted display of hives and other bee-gear; and to Mr. R. W. Davies a bronze medal has also been awarded, we presume, for his cheap hive, for which we have been informed that throughout all the time of the Exhibition there has been a continuous succession of orders.

To the Rev. V. H. Moyle has been awarded a silver medal for his display of honey and its varied applications in the form of beverages, confectionery, medicines, &c. The exhibit of Mr. Moyle we consider was most effective, as it showed and proved the capabilities and developments of honey; and connected with Mr. Moyle we are glad to associate Messrs. Huntley and Palmer, to whom was awarded a gold medal; and conspicuous among their exhibits were the now famous Honey Drops. Attention has been drawn to these by our contemporary the *Confectioner*, which gives the following description of them:—'Among the latest of Messrs. Huntley and Palmer's productions is the "Honey Drop," a biscuit about the size and shape of a florin. It is of a delicate golden brown colour, and moderately soft in texture. It is a line which will live. *Honey seems to be fast finding its way into our manufactured goods as among the ancients.\** English honey only is used; the foreign is so adulterated with glucose that this house will not buy.'

And now that the curtain has fallen and the

\* In the same number of the *Confectioner*, from which the above is extracted, is a very interesting article by Professor King on 'Cheese-cakes—their Antiquity,' in which are given several recipes for making these delicacies. In the majority of them honey is used either as a constituent, or the cake is served, or fried, or boiled with honey. In fact, honey appears always to have taken the place of sugar. Philoxenus of Cythera describes a banquet as follows:—'And the beautiful vessels which came in first were brought in again full of every kind of delicacy. And in the middle was placed the great delight of mortals . . . and its name was Amylтус . . . which they call Jupiter's sweetmeats. Then were distributed plates of . . . very delicious . . . and a cheese-cake compounded of cheese, milk, and honey.' There is further information in the article which might prove most interesting to those who desire a better and a fuller knowledge of the use of honey by the ancients.

doors are closed, we are in a position to congratulate the Association on the work it has done. Very few of the millions who have flocked to the Exhibition have neglected to inspect the Bee Department. It has been described as the most interesting portion of the Show. Young and old, rich and poor, the country-bred and the city-bred, the peer and the peasant, have had an opportunity of seeing the hive and its wonders, and of watching the working of the honey bee. The desire to know more of the interesting and fascinating pursuit of bee-keeping has been sown in many a heart, and the result of this will be seen 'after many days.'

The results of the Exhibition have been direct and indirect. During the time it has been opened the Bee Department has received three hundred orders for different kinds of goods. Five hundred pounds have been taken for goods, honey, and bee-literature. One hundred members have since the commencement of the year joined the B. B. K. A.; this large accession may to a great degree be placed to the credit of the Exhibition.

We must postpone to our next the consideration of the indirect benefits resulting from the Exhibition.

#### BRITISH BEE-KEEPERS' ASSOCIATION.

##### EXAMINATIONS, 1884.

###### *Second-Class Examinations.*

List of Successful Candidates placed in order of merit:—  
Warden, Charles, Clarendon Park, Salisbury, Wilts.  
Leake, J., jun., Beacon Street, Lichfield, Staffs.  
Kambridge, W. S., The College, Marlborough, Wilts.  
Howard, J. H., Holme, near Peterborough, Hunts.  
Farrington, G., Pond Green, Burslem, Staffs.

###### *Candidates having passed Third-Class Examinations.*

*Bucks*—  
Brisker, P., Ellesborough.  
*Carmarthenshire*—  
Jones, M. R., Llandilo.  
Lewis, L., Oswald, Llandilo.  
Spurrell, W., Carmarthen.  
*Derbyshire*—  
Bryan, T. M., Clay Cross.  
Griffin, G., Clay Cross.  
Handby, W., Hasland.

*Herefordshire*  
Meadham, Moses, Huntington.

*Hants*—  
Howard, J. H., Holme.  
Reynolds, G. St. Neots.

*Norfolk*—  
Dobbie, Henry, Thickthorn, Norwich.  
Lilley, Edward, Buxton, Norwich.

*Staffordshire*—  
Clowes, E., Milton, Stoke-on-Trent.  
Farrington, G., Pond Lane, Burslem.  
Farrington, S., Stafford.  
Handby, G., Wolverhampton.  
Leake, J., jun., Beacon Street, Lichfield.  
Warren, M. Leake, near Stafford.

*Surrey*—  
Ealson, James, Farncomb, Godalming.

*Wiltshire*—  
Kambridge, W. S., The College, Marlborough.  
Bartley, Frank, Rowde, near Devizes.  
Day, E., Milford, Salisbury.  
Warren, C., Clarendon Park, Salisbury.



The above list does not include those candidates who were examined at Reading on October 1st and 2nd; the result of this examination will be published in a future number of the *B. B. Journal*.

### THE BEE AND FRUIT FARMING COMPANY.

Besides the British Honey Company, which we have already noticed, we desire to draw the attention of the bee-keeping public to another Company with the above title. The object of this latter Company is, 1, to carry on the business of bee-farming, embracing the raising of bees, the production of honey, and the supplying of bee-appliances; 2, fruit-farming and preserving, market-gardening and dairying; and, 3, acquiring a sub-lease and the good-will of the Cray Valley Bee-Farm, lately occupied and carried on by Jesse Garratt, Esq. (Secretary of the Kent B. K. A.), at Hoekenden, St. Mary Cray, who is the Managing Director of the new Company. (For further particulars, see Advertisement.)

### LINCOLNSHIRE BEE-KEEPERS' ASSOCIATION.

We have much pleasure in inserting the following resolutions passed by the Lincolnshire Agricultural Society:

Extract from the minutes of a meeting of the Finance Committee and stewards, held at the Society's Council Room, Lincoln, on Friday, the 8th of August, 1884.

Resolved unanimously, upon the motion of Mr. Edward Paddison, seconded by Mr. Percira Brown, that the thanks of this meeting be conveyed to Mr. R. R. Godfrey and other members of the Lincolnshire Bee-keepers' Association for the assistance so readily afforded by them in the management of the Bee Department of the Grantham Exhibition.

Ordered, that a copy of the foregoing resolution be forwarded to Mr. Godfrey.

The following is the report drawn up by the Rev. George Rayner, and concurred in by Mr. Henry Yates:

"On acting as judge of the above department of your show at Grantham, in conjunction with Mr. Henry Yates, I beg to offer a few remarks on the various divisions of the show. Taking the more important classes in their order, we come first to the several foreign varieties of the honey-bee, for which liberal awards were offered. Here the number of entries was small, and, with the exception of the prize exhibits, moderate only in quality. I consider this an important part of the show, inasmuch as the Italian and other Eastern races of bees are especially useful to the farmer in fertilising the albine and red clover, upon which the ordinary English bee is rarely seen at work. In the class for English bees the specimens exhibited were fine and pure in race. The honey classes were excellent, both as regards quantity and quality, and gave evidence of the beneficial result of the fostering care bestowed by the Lincolnshire Society on bee-culture at its annual shows. The large quantities of honey exhibited by several agriculturists of note, and the cleanly and saleable form in which it was shown, forecast an important future for the industry of bee-culture in your county. The fact that at the early season at which your show was held, nearly a ton and a half of honey was exhibited, excellent in quality, and splendidly shown,

speaks more on behalf of the usefulness of such exhibitions than any words of mine could. The exhibitors in Class 14 for collections of bee furniture, brought together an excellent display in 500 or 600 articles, adapted for every possible want in the scientific and artistic culture of the honey-bee. I cannot conclude this brief report without allusion to the manner in which the entire show was conducted, in the orderly and neat arrangement of the classes, the selection of the site, and in all the minor details, which go towards rendering exhibitions of this kind both popular and successful in a pecuniary point of view, and which evince the greatest care, diligence, and energetic action on the part of your Secretary of this department (Mr. R. R. Godfrey), who is so well qualified by his long experience for the task he undertook."

### RECENT INVESTIGATIONS INTO THE STRUCTURE OF THE EGG ORGANS OF THE QUEEN.

By FRANK R. CHESHIRE.

It is now fitting that I should endeavour to point out the chief facts new to apiculture, in the satisfactory determination of which I have been very greatly helped by the twenty-five queens forwarded to me with so much goodness by those already thanked; and in addition Capt. J. C. Hayslam, R.N., Bideford, Mr. W. T. Joyce, Farnborough, Mr. Kenry, Dunnington, and Revs. Scott, of Hartlip, and Sisson, of North Walsham, and a kind donor who is not named. Useless queens would still be of service for a year or two and by explained.

It is well known to intelligent bee-keepers that the queen meets the drone in the air, the latter being, I feel strongly of opinion, neither guided by hearing nor scent, as many have supposed, but by the eye; he for this purpose being furnished with a far more highly developed optical organ than even the worker. It is also known that after her fourth or fifth week the queen becomes incapable of copulation, and should she lay, furnishes nothing but drones, and is known as a drone-brooder. It has, in addition, been demonstrated anatomically that the drone produces a vast number of active thread-like bodies called spermatozoa, and that these are transferred to the queen, where they may afterwards be found stored in a receptacle, to which the name 'spermatheca' has been given, and that these threads are the active means for converting an egg that would otherwise have produced a drone into a worker, or it may be a queen.

Many problems have had no answer, and most conspicuously that one which asked *how* these threads were transferred to the eggs, and it is especially to this that I shall turn my attention. But since the investigation shows beautifully that the queen after mating becomes most completely a creature carrying all the essentials of the two genders within herself, it will be necessary to turn some thoughts to the organization of the drone.

If the abdomen of a queen be cut open down the sides by fine scissors, and the three first dorsal (dark) plates carefully removed, we discover two very large organ-filling nearly the whole of the enclosed space. These are called ovaries, and consist of from forty to sixty tubes each, all lying side by side, and gathered into a bundle. These tubes (ovarian tubes), in which the eggs are matured, are at the upper end, very small, and here each egg is represented by an initial cell only; but as this develops and enlarges it passes on, room being made for it by the escape of the mature eggs at the wider lower end. These two ovaries are covered below by two very delicate membranous forms, into which their large ends

I have received other bees of special interest, to which I must refer in another connexion. Mr. Sisson's second queen, as he supposed, was diseased even worse than the first, and has given some new points which will no doubt repay investigation.

are inserted, and which may be compared to funnels, the two delivery pipes of which unite and form a single tube (the common oviduct), the three taking the form of the letter Y. If a drone were to be opened in like manner, we discover in the same relative part of his body two organs much smaller in size, containing about 500 tubes individually minute, but in which are produced the thread-like spermatozoa very much as the eggs are formed in the queen.

The ovaries of the queen and the testes of the drone are, then, homologues of one another. Two canals, like the oviducts in the queen, convey these threads, as matured, to a store chamber called the *vesicula seminalis*, where they await the object of their development. The homologue of this store chamber is the spermatheca of the queen. At the time of mating, these spermatozoa require a vehicle or medium in which they may be floated into their proper destination; and to supply this medium a gland is provided called the *glandula mucosa*, into which the *vesicula seminalis* opens, and at the time of ejaculation the mucous secretion of the gland and the spermatozoa are sent forward together. The mucous gland, we shall presently see, has also its homologue in the queen, which now we had better scrutinize. Not far from the commencement of the common oviduct, and fastened by very complicated muscles to the fifth abdominal ring, we find a globular body about the one-third of the size of a common pin-head (one-twentieth inch in diameter), and which glistens like burnished silver, because it is covered all over with marvellously delicate air-tubes (tracheæ), which reflect light like a duck's feather does when plunged under water. The smallest roughness will break the spermatheca from its attachments, and will frustrate any endeavour to discover how it is filled up and used, but with it separated, should accident detach it, we can make out its own structure with any microscope having even a really good inch objective (a quarter is of course better). The tracheæ, which cross and inter-lace so as to form a very close net, cover the spermatheca almost entirely from view; but since these tracheæ never enter the sack itself, they may, by very careful teasing with needles,\* be so divided that at last the spermatheca will escape, and may now be examined under a cover-glass. It is seen to be a transparent bag having no visible structure except near the outlet, where it is lined with epithelial cells. Through its sides, if the queen were mated, we discern only a perfectly clear fluid, not granular, as stated by Leidy (Langstroth, page 213), but as described by Louchart (Langstroth, page 127). If, on the contrary, the queen had been recently mated, the whole interior is densely clouded and semi-opaque, since it is perfectly filled with spermatozoa; but as older and yet older queens are operated upon, the spermatozoa decrease in number; but instead of being generally diffused, are gathered into a tolerably compact mass, which lies near the aperture of the spermatheca, the remainder of which is filled with a clear fluid as in virgin queens. This compact mass of spermatozoa (as seen by a half-inch objective) much resembles a dense ball of horse-hair, and from the surface of it from ten to twenty spermatozoa rise in different spots like microscopic eels long and thin, curl and twist with much grace while they hold on with their tails; after a few seconds they lapse into quietude, sink back into the mass to be in turn succeeded by others, and in a warm room this most curious set of movements will continue for upwards of an hour.

The closing valve of the spermatheca, for it possesses a marvellously beautiful one, having been brought away with it, it is worthy of note that no spermatozoa escape, and if we squeeze the spermatheca flat with the cover-glass, the valve still holds fast. The pressure increased,

the delicate bag at length bursts, and one of the most marvellous sights the microscope is capable of affording awaits us. The spermatozoa escape in tufts, each containing hundreds of thousands. These tufts have a beautiful arrangement, reminding one of a girl's back hair combed out after plaiting; but each spermatozoon wriggles to be free, and quickly they are widely spread, curling and meandering with an energy which baffles description. Their powers in a few minutes begin to wane, and then one after the other they take a form closely resembling two S's one over another, surrounded by a rather larger O; and when all have sunk to rest, this curious pattern, repeated with strange regularity, covers the field. It is my idea† that this form is the one into which the spermatozoon puts itself after entering the egg, when the head of it, which is long and thin (not rounded as Girdwoyn draws it), and not quite at the end of the thread, would lie in contact with the germ yolk, the well-understood position needed for fertilisation.

I have said enough already to show the absurdity of the pressure theory so called, which repeats Wagner's most crude guess that the squeezing of the narrow worker-cell thrusts out spermatozoa from their containing sac. Of course, no knowledge of the surpassingly beautiful structure of God's animated creation is needed for a guess like this, and only in its absence could any one have ventured to make it. Those who have been so confident in telling us the spermatozoa were squeezed out would have rebuked themselves if they had only thought enough to have asked how they were squeezed in. Let us now pass to the consideration of the means by which egg-fertilisation is actually brought about.

Let us suppose that a complete spermatheca is now before us; as we turn it we get it into such a position that its outline is not unlike the back of a man's head carrying two large and prominent ears. These latter are the upper ends of two glands about the hundredth and thirtieth of an inch in diameter long and twisted, in form resembling bed-bolsters, these meet together and form a junction near the aperture of the spermatheca. They each consist of gland-cells, in the midst of which runs a tube from end to end, which continually enlarges during its course. This tube gives off thousands of tubules which pass to the distinct coils and gather the tiny quota of secretion each furnishes. The main pipes of the two glands unite, so that all the liquid produced is ready to be discharged near the mouth of the spermatheca. Our greatest difficulty now faces us. We find that the spermathecal aperture enters the side of the common tube carrying the glandular secretion, but that five main muscles are so contrived that the spermatheca when in repose is shut by a plate which faces the point at which its aperture enters the gland-duct. In this position the gland-duct is also closed by the same plate, but if by the will the insect or the need‡ of the queen spermatozoa are to pass out two muscles draw the spermathecal aperture away from the plate (directly from its face). This frees a few spermatozoa, and the now liberated glandular secretion by its outflow sweeps them on into a canal which runs by a pretty long path towards the common oviduct. A most marvellous adaptation here arises. The spermatozoa yielded by the drone are probably rarely less than 4,000,000, but these need to be economically utilised, as if they were shot out haphazard they would be exhausted long before the queen's death and we should get a drone-breeder. We see how a small number are now sent travelling on their errand, but the duct through which they pass I find to be the centre of another gland which is richly provided with muscular fibres and nerve threads. The gland is, no

\* This I have not yet actually verified by observation. It is a matter yet to be done.

† The movement is probably purely reflex.

‡ This had better be attempted in a small drop of gl. cerine. Water is not so good.

doubt, excited to secretion by the presence of the spermatozoa. All physiologists will see this at once, e.g., food excites our salivary glands to the secretion of saliva and the stomach to the secretion of gastric juice. Spermatozoa thickly present will cause the addition of large quantities of fluid which will more widely separate them. Their absence will yield the action which will send a new contingent forward as I have described, and so they come to be paid out in some regularity. The muscular threads moving them forward as required.

Tracing the duct through which they pass on, I discovered a spot in which the channel seems to fork, one going into the oviduct near the ovipositor and the other entering near the junction of the right and left oviducts. Surely this has a meaning. The former channel seems nearly obliterated in laying queens, and my best of its were sorely taxed by it. There is but little doubt in my mind that this passage in the early life of the queen is wide, and is the one by which the spermatozoa pass up towards the spermatheca after mating. The muscles before referred to, in order to affect this, reversing their action just as the muscles of the oesophagus do in higher animals in the act of vomiting. The horse, by example, when he drinks carries water up by a muscular action in boldness into his stomach,\* but in vomiting the same muscles grasp material and carry it towards the mouth. If this be so, the spermatozoa are 'squeezed in' by a sucking action at the ovipositor, and all becomes clear, and we also get the key to the reason that the queen, quite early in life, becomes incapable of mating.

(To be continued.)

## ASSOCIATIONS.

### BRITISH BEE-KEEPERS' ASSOCIATION.

#### DISCUSSION ON DR. WALKER'S PAPER ON FEEDING BEES.

The Chairman thanked Dr. Walker for his most interesting paper, and invited the company present to express their opinions on the same.

The Rev. G. Raynor congratulated the audience on the valuable information they had just acquired, and said that the views put forward by Dr. Walker, with one or two exceptions, he (the speaker) had proved practicable and best by his own experience. He approved of the bottle-feeder in certain forms, and, as they all knew, had lately brought into notice a new one himself. He did not push the sale of it for the sake of any profit, but because he had in practice proved it to be a good one. He did not suppose that Dr. Walker referred to his feeder, because he knew there were several different appliances of this character in existence. The idea upon which his own contrivance was founded occurred to him from an experiment which he made with a feeder that had now been before the public for thirty years. It was the invention of Mr. Pettitt, of Dover, and was a float-feeder consisting of a wooden bowl, seven or eight inches in diameter, with a central tunnel through which the bees ascended. Instead of using this in the ordinary way he inverted it placing a bottle in the tunnel and covering the lower part with wire-cloth. The bees fed remarkably well from this feeder. They ascended into the dome formed, which was lined

with cloth, and was impervious to the escape of moisture or heat. They appeared to make use of the feeder in all weathers, and this arrangement had suggested to him the invention, which had lately been put forward in his name. Curiously enough after using this feeder for several years he came across a book, published in America on apiculture, or more particularly on queen-rearing, by Mr. Alley, in which was described the 'Locke Feeder,' of the precise pattern he (the speaker) had been using, and for which a patent had been taken out in America. With regard to Dr. Walker's remarks on spring dwindling, he was of opinion that bees hatched in late autumn were a disadvantage to the colony. They are more liable to dysentery, often because they are unable to leave the hive during the winter; and his experience was that bees hatched before the month of September lived considerably longer than was generally believed. He thought there was no doubt that well-seasoned bees going into winter quarters, having been bred as early in the previous summer as the middle of September, do exist up to the following April or May. His belief was that young bees hatched after the middle of September and throughout the month of October did not winter so well as the older bees which had attained to greater strength and were possessed of more stamina. Two years ago he had introduced, in the month of September, a Syrian queen to a strong colony of black bees. The queen proved to be a 'drone-broeder,' and, consequently, no Syrian workers were produced. The colony remained *in statu quo* until the following May, when the black bees were found to be nearly as numerous as when the Syrian queen was introduced. Another queen was inserted, and the colony became as flourishing as any in his apiary. Hence we have a certain proof that bees bred in August and September exist for a period of eight months at least. With regard to the material composing the food of bees, he quite agreed with all Dr. Walker had stated.

Mr. Helmer said he came to listen, and had learnt a great deal that evening. He knew nothing about feeding bees, but thought he could give the reason why pure sugar should be better as food than pound sugar. The latter contained potash salts, which were injurious alike to man and beast, and would therefore be very liable to derange the digestion of bees. He wished to take this opportunity of saying that horshoof honey, so far as he had examined it, was perfectly genuine. He stated this in justice to the man whose name he had mentioned more than once in that room.

Mr. Blow would like to ask Dr. Walker whether the pea-flour should be added at the early stage of preparation. He (the speaker) did not think the pea-flour added to the early should be submitted to any high temperature, and it should be added last.

The Rev. T. Sissons said, for some years he had found a difficulty in preparing bee food, and at last he discovered that the cook must be blamed for this. He had now adopted the experiment of simply taking the same preparations of sugar and boiling water, putting them into the extractor and revolving till the whole of the sugar was extracted, and using at once. He had found no candying on the part of the sugar, and no dysentery on the part of the bees.

Mr. Zeb-tunmyr said he agreed perfectly with Mr. Raynor with regard to bees bred late in the autumn. He considered them rather a disadvantage to the hive than otherwise; and in his opinion, bees which have not been able to fly about before going into the winter will scarcely see the spring. He desired to say something about the utility of supplying bees with water during the spring months. According to his experience spring dwindling can be greatly reduced by providing bees with the necessary water within the hive, especially if they are fed to stimulate breeding. Thousands which would perish on chilly days while searching for water will be kept indoors and

\* The 'India-rubber brothers,' who show how they can do all that men were not meant to do, drink head downwards, the wine (it is coloured water, not wine, as that spoils the quality of the India-rubber) rising into the stomach by muscular grasping of it in the oesophagus.

saved. To what extent bees require water during the breeding months may be seen from the fact that between the middle of March and the middle of May one stock consumed no less than a gallon, given to them over the frames in a bottle arranged for the purpose. With regard to Mr. Sissons's remarks, he said that he also never boiled his sugar, but simply dissolved it in hot or boiling water, and it had always answered the purpose.

Mr. W. O'B. Glennie endorsed Mr. Sissons's remarks. He had never used the slinger for the purpose mentioned, but he quite agreed that it was not necessary to boil the syrup. During the first few years of his experience as a bee-keeper, he used to allow the syrup to boil about ten minutes, and he discovered that it candied, as he believed in consequence. At that time bee-feeders were not so plentiful as now, and he made use of a pickle bottle for the purpose with canvas covered over the top. Sometimes there was a thick coat of candy over the holes and unless this were removed the bees would starve. At last an old woman told him the cause of this, which she attributed to the boiling. He quite appreciated the force of Mr. Sissons's observations respecting the cook. He prepared the food himself, but not till after all the servants were gone to bed.

Mr. Garratt was surprised to hear the remarks of Mr. Raynor and Mr. Blow to the effect that late autumn bees are of little value to the hive. At the same time he treated their opinions with great respect. With regard to feeding, many established bee-keepers recommended that bees should not be deprived of their honey during winter. He was of opinion that those hives which were least tampered with in the autumn were best in the spring. There was one method of feeding which had not been alluded to. That was feeding from behind the dummies. The plan was adopted very frequently of giving a space or passage beneath the dummy at the rear of the hive to allow of bees passing under and feeding in the compartment formed by closing up the bees in the centre of the hive. There was considerable advantage in this, because feeding could take place at the back, and be done in secret. Much of the honey gathered in the latter part of the season was very bad in colour, and of questionable flavour and quality. Instead of using this honey he let the bees have it, it being their natural food. He thought the bad-coloured honey, referred to by Mr. Zehetmayr, was very unattractive, and the public ought not to be asked to buy it. He had found that within a radius of ten miles of London the honey deposited was of a very dark colour, and seemed to be made so by the condition of the atmosphere. With regard to the solid, dry food, alluded to by Dr. Waller, there was much difficulty in preparing it, and very little was known on the subject. Purveyors of bee appliances would do well to add it to their catalogues. It was contrary to his experience that sugar usually candied after being boiled. He always preferred his food in this way.

Mr. Stewart recommended occasional feeding at very short intervals. The bees had collected continuously this season, but some years it happened that a few fine days were succeeded by a week of cold and wet weather. At these times he thought it most desirable to feed the bees.

Mr. Garratt apologised for rising again, but with regard to Mr. Zehetmayr's remarks respecting bees drinking an inordinate quantity of water, he would like to refer to his own experience on this head. Last spring there was severe frost in the middle of April, with cold east winds. At that time his bees came in clouds to the water, their thirst being insatiable, and he lost an enormous number by drowning.

Mr. Drialwater said, with respect to dry sugar feeding, he had tried Mr. Hewitt's system last winter, as recommended in the *Bee Journal*, with one hive. They

wintered just as well as any of the others. He had fed with syrup, in the usual way, but they did not get on so well in the following spring as those which had syrup food.

Mr. A. Mellidge, as a bee-keeper of seven months standing, wished to know whether it was not a singular circumstance for a drone queen to rear drones in worker cells.

The Rev. G. Raynor, in answer to Mr. Mellidge, said that under abnormal conditions—such as the existence of drone-breeding queens and fertile workers—drones of the size of worker-bees were constantly produced in worker-cells—perfect drones in every respect except size; and it was generally believed, by Dr. Dzierzon and other scientists, that such drones were capable of propagating their race.

The Rev. T. Sissons said Mr. Garratt's remarks respecting dark coloured honey, if allowed to go forth to the public without any qualification, would damp the ardour of all suburban bee-keepers. It was distressing to think that the productions of the bees within eight or ten miles of London should not (according to Mr. Garratt) be offered to the public. When he (the speaker) lived within the area of London smoke (the Woolwich side of Shooters' Hill), his bees produced the best honey, for which Messrs. Neighbour and Son gave a good price. Since then he had moved to Beckenham, with the result that his honey was of a darker colour than the Woolwich produce.

Mr. Garratt, after Mr. Sissons's assertion respecting dark-coloured honey, desired to withdraw what he had said respecting it.

The Rev. G. Raynor would add a word of caution with regard to Mr. Garratt's system of feeding bees on the dark-coloured honey. If collected from the aphides it was the worst food they could consume. A leading article in a recent *American Bee Journal* warned bee-keepers, in the strongest terms, against feeding with the honey collected from the aphides, dysentery and death being the certain result. With regard to Mr. Glennie's mode of preparing syrup, Mr. Root in his *ABC* book commends it, stating that he never boiled sugar, but simply poured hot water on it.

Mr. Hart explained that Demerara sugar was coloured more or less according to the market for which it was intended. It was always sent darkly coloured to the American market, and a lighter brown to the English market. The cheapest and best sugar for feeding purposes was that called Dutch crushed, which was similar to loaf sugar, but, generally speaking, was nearly always cane-sugar. He thought spring dwindling was due to insufficient pollen in the hive—in fact, he had proved this by his own experience. He quite agreed with Mr. Raynor respecting the honey collected from the aphides.

Mr. Garratt thought that Mr. Raynor's observations hardly convicted him of suggesting an injudicious plan for feeding because he had made no admission that the dark honey was collected from the deposit of aphides. He attributed the dark honey in his own case to the privet-hedges in the garden. The honey deposited previous to the privet coming into bloom was of a light clear colour, but afterwards it became dark. On examining the dark honey he felt convinced by its scent and flavour that the privet had produced it. He immediately caused the privet blooms to be cut off, and no more dark honey appeared. The bloom of lime-trees was known to produce dark honey. His neighbourhood had not been affected very much with blight that year, and he considered it very much an open question whether the dark honey he had referred to could be attributed to the aphides.

Mr. Sambels said that in August, 1883, his bees gathered honey which resembled port wine in colour, but was, nevertheless, of so good a flavour that it gained a

special prize at the county show. Early in the spring of the same year the honey produced was of a light colour, as it had been last spring. With respect to the best sugar for feeding purposes, he had had the pleasure of hearing the Honorary Secretary of his Association lecture on bee-keeping. That gentleman stated that bees did not winter well on syrup, and that if reared on this food in late autumn they were invariably deteriorated in physique. He would like to hear some opinions on this point. He found that cane-sugar had been recommended pretty generally in the columns of the *Bee Journal* and by many others, and he recollects Mr. Hehner saying in his lecture that cane-sugar was the nearest approach to honey. He always used cane-sugar for domestic purposes as well as in the preparation of bee-food. This latter he prepared in the usual way by boiling, and he had kept the syrup for four or five or fifteen months without the least crystallisation setting in. His experience did not correspond with that of the Honorary Secretary to whom he had alluded.

Mr. Hart said that Dutch-sugar was one of the cheapest sugars he had found in proportion to the saccharine matter it contained.

Mr. Zehetmayer said Mr. Drinkwater had mentioned Mr. Hewitt's system of wintering bees on, or better between, frames of candy. This he considered not only dangerous, but fatal to any stock. In mild winters, such as the last two, which were no winters at all, the stocks may survive and see the spring, but in a severe winter, with a considerable spell of cold days, he was more than convinced that no stock so wintered would survive. Any one who has opened a stock on a frosty winter day and seen how bees crowd together and into the cells, filling up every empty space within the cluster, in order to keep up the required warmth, would agree with him and recognise the fallacy of this mode of providing bees with food.

Mr. Brown had seen several stocks that autumn which had been dry sugar fed. This food was of a stimulating character. Colouring matter was put into Demerara sugar, there was no doubt, for he had noticed it change colour while in the feeder. With regard to spring dwindling from want of pollen, he recommended good food in the early spring to counteract this, as it induced the bees to breed, and supplied them with pollen.

Mr. Blow desired to correct Mr. Garratt's statement that he had supported Mr. Raynor in saying that bees raised late in autumn were useless to the hive.

Mr. Stewart said that all particulars concerning Demerara sugar would be found in the report of a case which came before the United States' Courts in the autumn of 1878. The Secretary of the Treasury of the United States *versus* Beut. The whole subject of the adulteration of sugar was gone into at that trial. The charge was that the importers had defrauded the Revenue of the country by adding dilt to the sugar. The Government, however, failed to establish their case.

The Chairman thought they had listened to a most interesting discussion. He had himself burnt a great deal, some of his most cherished opinions having received a violent blow that evening. He had always understood that breeding should be stimulated as long as possible. He only gave his bees foundation, and candy, and syrup in the ordinary way.

Dr. Walker, in reply, said that most of the queries raised by some speakers had been answered by others in the discussion. He did not profess to do more than give his own ideas and opinions. With regard to spring dwindling, Mr. Raynor had misunderstood him. He did not wish spring breeding to be carried on excessively. That would depend very much on the state of the season. This year they had a mild autumn, and that day the bees had been flying out in large numbers, and, probably, at this time there would be a large

amount of brood in his various hives. He thought the question of rearing brood in the autumn depended entirely on the weather. No doubt, bees raised too late in the autumn were useless to the hive. With regard to supplying water to bees, as far back as the time of Aristotle this was considered to be absolutely necessary, that philosopher alluding to the subject. The advantage of dry feeding was that pea-flour was mixed with the sugar, the former being very much like pollen in its character. This food, no doubt, stimulated early brood-rearing. Of course, it must not be used in the late autumn for the reasons already given. The question of making the candy was merely one for the cook. His servants had come to grief over the task, but he had succeeded himself very well. This was, perhaps, easily understood, for he maintained that a doctor was nothing if not a cook. He was not surprised to hear a conflict of opinions on the subject of wet and dry feeding. That fact was only a confirmation of the old adage, "So many men, so many opinions." With reference to the dark colour of private-honey, he might say that his bees had produced some which was quite black, with little or no flavour, and, of course, repulsive in appearance. He had thought of naming it "Mr. Myle." He had tried once or twice feeding of the bees on candy, and poured it into the frame while it was hot. It answered fairly well. Candy was very highly thought of in America as a mode of feeding bees. With regard to the learned discussion about Demerara sugar, he was grossly ignorant on that subject. He had always thought the brown sugar was best, that it took less brown sugar to sweeten your cup than white sugar.

The Rev. G. Raynor proposed, and the Hon. and Rev. Henry Bligh seconded, a vote of thanks to Dr. Walker, who briefly acknowledged the same.

The Rev. H. R. Peol proposed, and Mr. Garratt seconded, a vote of thanks to the Chairman, who they regretted would be unable to attend their meetings so regularly in the future as heretofore.

The Chairman, in thanking the meeting, regretted his inability to retain any longer the honorary secretaryship of the Association. As a result, but a beneficiary, in his family he valued this impossible.

#### STATFORDSHIRE BEE-KEEPERS' ASSOCIATION.

*Annual Certificate.* 2nd Class, George Farrington, Smallhale, Burslem; John Lenke, junr., Glebe Street, Lichfield. 3rd Class, S. Farrington, 11 Foregate Street, Stafford; E. Clowes, Hole Farm, Farm, Mill on, Salsome-Trent; S. Warron, 21, Market Place, Leek; G. Hambley, Walham's Hill, Wolverhampton.

*The Bee Club.*—The Bee Tent has visited twenty different shows in the county. Five of which were of two days' duration; and, thanks to the able and careful management of the Rev. G. R. Biley, and the skill of Mr. Rollins, the Association expert, has handed over a balance of £31.17s.1d. to the account of the Association.

*The Expert's Autumn Tour.* Mr. Rollins completed his autumn tour on October 14th, after thirty-two hard days' work. In all he visited 192 members of the Association, besides other bee-keepers who called him in for advice. He examined 591 half-stamp hives and 370 straw skeps, and although unable to ascertain the amount of honey taken, he accounted for 7535 lbs. taken from some of the members on whom he called. In the spring he visited altogether 122 members and examined 377 hives altogether, so we may fairly assume that his visit is becoming more popular, and that Staffordshire has taken advantage of the abundant harvest of 1884.

### GLAMORGANSHIRE BEE-KEEPERS' ASSOCIATION.

Referring to Mr. Gibbins' letter in your last issue about the Glamorganshire Association, there are, I believe, several persons in this neighbourhood who would become members of the Association. At the same time I think there should be two distinct Associations for Glamorganshire—east and west: one having its headquarters at Swansea, and the other at Cardiff. I believe an Association could be readily formed in this district if any gentleman would undertake the duties of Secretary. —W. H. JENKINS, *Argaty, Sketty, Swansea.*

### NOTTS BEE-KEEPERS' ASSOCIATION.

In your Editorial Notices of November 1st, you refer to the representation of the Notts B.K.A. at the Conference. I (and, doubtless, other bee-keepers) would be glad to know if there is really an Association in Notts. When the question of forming an Association was first mooted, I gave in my name as desirous of becoming a member: I received notice of a preliminary meeting for the election of officers, but was unable to attend; and, though living only a few miles from Nottingham, I have neither heard nor seen any account of the Committee then formed having taken any steps to help and promote bee-keeping in Notts. If the Association is still in existence, I am much surprised that none of the bee-keepers in this neighbourhood have been invited to join. Surely, some steps should have been taken ere this in the interest of apiculture in the county of Nottinghamshire. —NORTH NOTTS.

### WESTMORELAND BEE-KEEPERS' ASSOCIATION.

I expected to have seen a letter from our Kendal bee-keepers in answer to an appeal from 'Windermere' in the *Journal* of the 15th of July for forming a Bee-keepers' Association. I see that our neighbours in Cumberland are going ahead with their Association, why should not Westmoreland have one at once, and not be the last of the English counties to have one? If some gentlemen would only take the thing in hand, I think others would follow. I shall be glad to do my part in forming one. —BOWNESS.

[The Reports of the Middlesex, Rutherghlen, and Belfast Bee-keepers' Associations will appear in our next.]

## Correspondence.

\* \* \* All Correspondents forwarding Letters for insertion in the *Journal*, Reports of Associations, Shows, Meetings, Echoes from the Hives, Queries, &c., are requested to direct their communications to 'The Editor of the "British Bee Journal," c/o Messrs. Strangeways & Sons, Tower Street, Upper St. Martin's Lane, W.C.'

### JUDGING.

The subject of 'Judgos,' started by 'Station-master,' and revived by 'Aparist,' is one so well worth discussing that, if no one more competent takes it up, I shall ask you to let me, as one who has had the misfortune to act as judge occasionally, to say a few words to keep the ball rolling.

'Station-master' is vexed because judges seem to have no rule as to the order of merit of clover, heather, fruit, &c. honey, and wishes to have some such rule laid down. But is that possible except the rule be most general? Some kinds of honey all would hold to be inferior; for them no rule is needed. But for others, such as for the three kinds named above, where are we to find the Herald's College to draw up the Table of Precedence?

I, myself, would rank clover-honey, both for purity of flavour and for its golden beauty, as queen over all the rest; but many others, undeniable connoisseurs, think clover too thin and tasteless and prefer heather; while others again think the delicious, peculiar bouquet of genuine apple-blossom better than either.

And when we have got our Table of Precedence, are there not other points, even more important, which very often reverse the first impressions of even 'practical bee-keepers?' Such as (if 'Aparist' will let me say so) judges almost invariably are. To illustrate some of these, let me give some facts from a show at which I chanced to be one of the three judges (not, let me add, either of the shows alluded to by your correspondents as their letters make plain). There was such an unusually good and even exhibit, both in sections and run-honey, that the judges had often great difficulty in deciding. Thus, in the class for 12 lbs. of section-honey, after weeding out all inferior lots, every sample had to be carefully tasted, every section examined and weighed before a verdict could be given with the result that the one which looked best had to be deposed, and, though a clover sample won the day, a much darker sample (apparently fruit) ran it very close. And this was even more the case in the class for extracted honey. After the judging surprise was expressed that a beautiful-looking lot of clear clover honey had been passed over for a much darker lot of fruit-blossom honey. And at first sight the judges, too, had thought the clover best, yet after a most searching testing they felt bound to prefer the darker lot for ripeness, flavour, and evenness of lot. I could give many other similar illustrations. The prize does not, and should not, always go to that which seems best to on-lookers, especially in the case of sections. Judges, far more than the public, have often cause to know that there are two sides to every section.

The question of the weight of sections alluded to above is so important that I should like to say a word or two upon it. The prize lists specify '1-lb. (or 2-lb.) sections.' Does this mean gross weight, i.e. including section-box; or nett weight, i.e. deducting box? In weighing at shows as judge, I often find sections (gross weight) which fail to turn the scale at 16 oz., and very few are more than 16 oz., especially in the case of the best-looking sections taken from supers tightly locked-up. In my own apiary this year I have weighed every section, and have found that well-filled sections have ranged from 14 oz. gross in the supers to 22 oz. in the case of sections filled behind an excluder down below, but these last are rarely even enough for show purposes. Now the 1-lb. section-box weighs from 1 oz. to 1½ oz., so that a 1-lb. section gross weight means only 14½ oz. or 15 oz. nett of honey. Yet undoubtedly a '1-lb. section' is so called because it is understood to contain in full 1 lb. of honey. As a judge I suppose one must pass a section weighing 16 oz. gross as a '1-lb. section of honey.' But it never seems to me quite fair in selling; certainly it is not fair to sell all sections at the same price as the weights given above prove. I myself weigh every section, deduct 1½ oz. for box, mark the nett weight on the section and sell at so much per oz. I have only spoken of 1-lb. sections, the case is stronger with the 2-lb.

If I have not already taken up too much of your space I should like to add a word or two more suggested by one or two expressions in your correspondents' letters. No judge that is worth his salt will resent even sharp criticism if only it be fair, but will welcome it as a help in what is no easy work. But I would ask the critics to bear in mind that the office of a judge is a most undesirable and thankless one, often calling for considerable sacrifices on the judge's part, and hardly ever, I should think, accepted by any one except out of a desire to help on bee-keeping to the best of his power. It may be that judges often try the forbearance of exhibitors

sorely; but have they not a claim upon that forbearance by the very fact that they are judges? Such at least is the feeling of one who has had the misfortune to be—AN OCCASIONAL JUDGE.

### EXAMINATION FOR THIRD-CLASS CERTIFICATES.

1. In reply to Mr. Webster's letter in your last issue, notwithstanding the instructions, permit me to say, though the point is of little consequence, the oral examination began before 11 o'clock, whilst the practical tests did not commence till a few minutes to 3 p.m. One of the candidates drove his bees in the open, the light in the tent being too bad; another, objecting to such publicity, drove subsequently in the tent with such light as there was. Mr. Webster's admission that he had to be orally examined after the late hour at which the practical tests concluded, places my contention in a clearer light, viz., that one examiner for six candidates is insufficient to avoid needless inconvenience.

2. With regard to the admission of the public within the net, I heard a stranger inside call out to one of the candidates who was driving, 'There she goes!' pointing at the queen; thereupon he was asked to withdraw. In my opinion no one should be admitted within the net except the examiner and candidate, as the presence of any gentleman (no matter how well known he may be to the bee-world) is apt to distract the attention of the candidate, and possibly render him nervous.

3. As one with some knowledge of examinations generally, I differ entirely as to the very good idea of an examiner placing himself in a position which should be occupied by the examinee, and then asking the candidate why he stood where he did. It is not a fair way of testing knowledge, as candidates may be diffident in requesting an examiner to change his place.

4. My suggestion that the maximum number of marks for each branch of the examination should be published (as is done in various public examinations), is simply a guide to a candidate in his preparation, and has nothing to do with the result of his shortcomings after examination. By this means we should learn what is the true value of the finding of the 'Queen test,' about which there is much difference of opinion, and as to whether the oral or practical test is considered 'the most vital part' of the examination; at all events, to know the standard (if there is one) would prevent the possibility of any one going in for examination without knowing the percentage of marks required to pass.

5. I do not doubt that the wintering capacity of a hive, &c., was asked orally, but the ability to answer a question from book-work seems to me a very different thing from the ability to practically judge the matter when manipulating a hive. Questions suggested by the special kind of hive selected for manipulation must surely be asked by the side of the hive itself. If this is not so, the test appears little more than finding the 'queen.'

Lastly, my object in presuming to offer criticism and suggestions on this matter is two-fold: 1st, if possible to elicit a defined standard of examination, which would probably have the effect of increasing the number of candidates of social position, who, as a rule, are unwilling to risk examination with undefined standards; and, secondly, that these examinations should be conducted with as little inconvenience to candidates as possible.

If my remarks should in any way contribute to these ends, I prefer that they should do so *suo motu*, and that the credit may appear impersonal and due to the regis of my hopeful motto—'PERSEVERE.'

### BEEES AND FLY-CATCHERS.

I am sorry to see in a late number that one of your correspondents has been destroying fly-catchers,

those very harmless and extremely useful birds, from a very mistaken notion that they devoured worker-bees.

I have been a bee-keeper for forty years and a constant observer of the habits of the fly-catcher for more than half a century; and a short time ago, I wrote a short paper on this bird which was published in the Transactions of the Edinburgh Naturalists' Field Club, of which I have the honour to be President; and in my paper I wrote thus:—'My principal object in writing these remarks on the fly-catcher is to contradict in the most emphatic manner an editorial note to a popular edition of White's *Selborne*, where this bird is most unjustly labelled as a destroyer of bees; and I much fear the erroneous impression conveyed by this note has been the death of many a poor innocent fly-catcher. I had frequently observed the birds follow a bee, seize it, and then settle on the gravel walk and beat it to death; but I felt sure the bird with its short beak dare not do this to a *worker-bee* on account of its sting, and that it must be feeding on the stungless drones, and I determined to ascertain this fact beyond the possibility of doubt. So the next time I saw the bird thus occupied, immediately it settled on the walk I threw a clod of earth at it and made it relinquish its prey. This I did at various times and always with the same result, viz., that, as I expected, the insect was invariably a drone and not a worker-bee.'

Now, the time when the fly-catchers require these fat drones for their young is after the swarming season is over, and then the workers themselves are turning out and destroying the drones, which are no longer necessary in the economy of the hive, and therefore the birds are assisting the workers instead of destroying them, and are consequently friends, and not enemies to the bee-keeper.

The fly-catcher is most useful in destroying many insects, which are injurious to vegetation, and I will mention one species in particular. We often see a white cabbage butterfly flitting about, apparently in the most innocuous manner over a bed of cauliflower or other plants of the Brassica tribe. But watch the insect closely, and, if a female, you will observe her settle first on one plant and then on another at short intervals. Examine at once the places where she settled, and you will find small white eggs deposited on the leaves. These soon become green grubs, which injure and disfigure the plants, in many instances where the grubs are numerous rendering the plants unfit for human food. Now, if you have our friend the fly-catcher in the garden, the butterfly's career is usually cut short before it has time to do much mischief. The bird's eye is upon it as it comes 'over the garden wall,' and it is soon seized, its wings bitten off and carried away by the wind, and the body swallowed or taken to the nest. Entomologists may say the insects should be allowed to live, but many of us will be of opinion that they should, at any rate, be kept within reasonable bounds, as nature intended by the birds, and that we prefer the vegetables minus the grubs.

Much as I like and value the fly-catchers, truth compels me to admit that they do occasionally give their young a few red currants; but considering the great service they render to the gardener, I never grudged them these, and it is only very rarely that they deviate from their habit of being purely insectivorous. If my remarks should in some degree prevent the destruction of birds so useful to both gardeners and farmers and so interesting in their habits to ornithologists my object will be attained; and I trust many will hesitate before they give credence to an accusation so unjustly made against our, as Gilbert White designates it, 'most mute and most familiar' little friend the spotted fly-catcher.

As regards the tits, I shall believe that they kill bees with stings when I have ocular demonstration of the

fact, that they eat dead bees by thousands I well know. A few years ago I kept a number of these birds, both *Parus major* and *Parus caeruleus*, in an aviary five foot long by four feet high, and there cannot be more amusing and sprightly pets from their almost unceasing activity; I frequently brought and placed in the aviary a number of dead bees picked up near the hive, the treatment of these by *Parus major* was peculiar, he carried the insect to a perch placed it under his claws then picked off the end of the body containing the sting and flung it away, and then ate the remainder; while this operation was proceeding it was a favourite trick with one of the blue-tits to cling to the perch with back downwards underneath his larger friend and steal the delicate morsel from between his claws, I never could induce any of these birds to attack a living worker-bee. May there not be some mistake by writers on this point as the result of too superficial observation? We know that when bees are disturbed in the winter time, or become active by some unusually high degree of temperature one of their first acts is to carry out any bees that have died in the hive, and it is possible the birds may have seized these as they were being carried out: this is, of course, merely a suggestion. I cannot write so positively on the ditto as I can on the fly-catcher, but I very much doubt whether any of our short-billed birds dare attack a stinging-bee.—A. B. HEARNE, *Polyarth House, Edinburgh.*

#### TITS AND FLY-CATCHERS.

Having so recently expressed my experience in the *Journal* on tits not killing my bees, I leave each writer and reader to enjoy his own opinion. But there is one item I would like to mention now we are about this subject. The only birds that I know of that will pick off the caterpillars from cauliflowers, &c., are the great tits (*Parus major*). I have frequently watched them, more especially during this plentiful season, and as I have a great dislike to boiled caterpillars and vegetables (especially second-hand) mixed, I encourage these birds by giving them homes to roost in (so they are under control without powder and shot) near a large bed of winter 'green-stuff,' and they may be seen every morning, at daybreak, taking their breakfasts on caterpillars, notwithstanding the fact that there are a dozen stocks of bees near.

I should like to say a word in defence of the fly-catchers, as I have always looked upon them as the most harmless and useful birds in gardens and orchards. I think, Mr. Editor, you hit the right nail on the head when you said, 'We want men of greater observation,' for how often I meet with remarks, even by the best authorities, that do not accord with facts from my observation; and here I may, perhaps, be allowed to mention that I know every bird, and every note of every one is familiar to me which visits this locality.

The common fly-catchers have always been encouraged to the fullest extent by placing homes for them, and will be unless they very suddenly change their nature. They have dwelt in perfect harmony around my bees for over thirty years. Two broods have been raised in the same nest in a pear-tree growing against my 'Nest' this season within a few feet of three stocks of bees, and the old birds were constantly flitting about amongst the flying bees close to the window where I write, and where I have watched them for hours, yet not a bee was touched, I believe.

They come back to the same spot year after year as I can testify from a clear proof—for, unlike the spotted fly-catcher mentioned by Mr. Baller as remaining about his neighbourhood 'all the year round'—ours are never seen after the middle of September, and arrive about the 10th of May.

A friend in Yorkshire writing on the 15th August,

last year, says, 'The pied fly-catchers are gone, we have lost the common, and spotted ones.'

Shrikes have become very scarce in this locality. Can any one inform me if they are to be seen in New Zealand? if so, woe be to the shilling humble bees! I have been hunting for some without finding any. I don't consider *Bombus terrestris* the best workers on red clover. There is a kind lighter in colour, and more plentiful, better.—JAS. HIAM, *The Wren's Nest, Ashwood Bank, Redditch.*

#### THE FLY-CATCHER AS A DESTROYER OF BEES.

Whether in accordance with the general habits of the English fly-catcher or not, they destroyed very many of my bees. For days my gardener and myself watched them, till at last I could stand it no longer, and shot all I could see of them. I believe them to be the most destructive birds we have in these parts, and would warn bee-keepers to get rid of all nests they find. I cannot agree with you that the quotation from Morris does not justify their destruction. I read it, he considers 'very trifling damage may be done by their destroying bees, from which it takes one of its trivial names, Bee Bird.' Most likely the reason the Rev. A. Booker-Hill lost none of his bees in his test was on account of the birds being young and not out of their nests. Those I shot (six of them) were all full grown. I feel quite satisfied as to their destructiveness; seeing I believe in this case.—D. F. HILLS, *Earls Colne, Herts.*

[We have already expressed our opinion that the extract from Mr. Morris's work on birds did not justify our correspondent in his 'wholesale massacre' of the fly-catchers; perhaps he may now be of our opinion when he reads the following curt but frank acknowledgment of Mr. Morris in reply to a communication from the Rev. Alfred J. Booker-Hill:—'Namburholme Rectory, Hayton, York, October 30. Dear Sir,—I do not keep bees, but I am quite sure that you are right about the fly-catcher. I will send your letter shortly to *Land and Water*, and I hope it may do good.—I am, dear sir, yours, E. O. MORRIS.' We hope to be able to finish this discussion in our next number.]

#### PRICE OF SECTION HONEY.

Is section honey only worth 8d. per pound? Not two years ago, unless my memory utterly deceives me, I saw Scottish honey advertised by a great honey-dealing firm in London at 5s. per pound. I do not know what that firm is getting for it this year, but a good deal more than 8d. per pound I expect. Surely what that firm can do, a Honey Company could do when it became equally well known. The difficulty appears to me to be, that the public do not yet know what section honey is, and I will give this proof of it. In June last sections were filling fast, and I thought it time to look out for a market. I accordingly took a section to my grocer and asked if he could take any off me. He asked me to leave it, and he would do what he could. At the end of three weeks he sold it for fourteen pence, telling me that many asked what it was, admired it, but simply did not care to buy it, because they did not know what it was. In the meantime a friend had tasted my honey, and bought all I had to part with at eighteen pence per pound. Since then I have seen it stated in the *Bee Journal* that section honey is not worth so much, and I was beginning to feel uneasy that I had robbed my friend and asked too much. When lo! the other day I went into another grocer's shop in another town and saw some beautiful sections for sale, I asked the price. 'Eighteen pence per pound, and we get very little profit out of that, but we are obliged to keep it because our customers will have it. Do you keep bees,



say? We should be very pleased to take any sections off you. I had sold all mine and was very glad I had, for the sections were supplied him by a working man who had some twenty or thirty hives, and deals a little in bee-furniture to the benefit of myself and others, and I know he had plenty more to sell, and I should have been sorry to have spoilt his market. Now does not this seem to show, that if bee-keepers will have a little patience, they may be able to keep the price of section honey up? Once let it down to cheapness, and, as a 'Herts-Gutter' persistently asks, will it pay? It were better to sell swarms at 12 each from straw skeps, than attempt to make a profit out of an average of twenty-five sections to each hive at 8d. per pound, produced in expensive hives with no little trouble.

Would it not be a good plan for the proposed Honey Company to take a shop in some fashionable thoroughfare in London, and deal in groceries besides? Many country share-holders might like to have their pocket-money returned to them filled with goods from their own shop, and thereby give the Company a chance to make a double profit. Or is there any leading shop in London, which would be willing to turn the honey part of their business into a company, and save the salaries of a manager, a secretary, and a few directors. J. O. CUTS-MARKER, *Hanwell Rectory, Rugby, Staff.shire.*

#### CONDUCT OF OFFICIALS APPOINTED TO SELL EXHIBITS AT SHOWS

Your correspondent 'Aparist' in your last issue, makes a grave charge against officials at shows; in fact, such that certainly, to my mind, requires fuller explanation, and I hope 'Aparist' whoever he may be, in common fairness to Associations generally, will name, and not leave all of us to be smarting under such an aspersion. Probably there may be something to be said on the other side. —R. R. GODFREY, *Hon. Sec. L.B.K.I., Grafton.*

#### QUEEN INTRODUCTION.

Now that the introduction of queens is brought so prominently before us, permit me, if you can spare space, to describe the plan we have adopted in our apiaries the last two seasons with the greatest success; not that I wish to claim my originality, as I believe it is similar to one that is recommended by several of our leading bee-keepers, but do not think it is so generally known or adopted as it should be, being by far the simplest, quietest, and, what is most important, the safest method I know.

We all know how docile and tractable bees are when driven, and it is upon this principle of intimidation only that success depends; once get the bees in that happy state and your new queen is safe. The *modus operandi* is as follows:

Place a large board in front of the hive sloping from the ground to the entrance, and on this put a cloth or newspaper, which more effectually covers the junction of the alighting board and the temporary board; now remove the old queen, give the bees a good smoking and quickly shake or brush them from each comb on to the paper in front, replacing the combs and quilts at once; no care need be taken of those bees that are on the floor-boards or hive sides, nor is it necessary to shake all the bees from the combs, merely a puff or two of smoke when putting on the quilts is sufficient for them. Of course the terrified bees outside commence re-entering the hive at once, the new queen is dropped amongst them and runs in as 'one of the family.' If any clusters form under the floor-board or porch, the usual puff of smoke sets them running. For several reasons the introduction should take place towards evening; after finding the old queen the whole operation takes but a

few minutes, and sprinkling with syrup so conducive to robbing—is entirely dispensed with.

I have introduced a great number of queens for strangers as well as at home on this plan, and have had but one failure, and that we attributed to a defective queen. If a stock has been queenless for some time it makes no difference. Some might object to the shaking of the brood-combs, but I always adopt that plan when extracting, and in all my experience have never detected evil results in any case. Very frequently queenless will be commenced, and even sealed, though all the time the new queen is reigning, apparently at peace with all her subjects.

The hope that some of your numerous readers may benefit by these few hints must form the excuse for trespassing on your valuable space by —ROLAND GREEN, *Redburn.*

#### THE CURE OF FOUL BROOD.

In the fewest words possible I must allude to the conflicting statements in last issue of the *Journal* concerning cure and two failures. With regard to Mr. Johnston, I can only say that he may or may not have acted as I describe, for I am totally ignorant of what Mr. Blow provides and what advice he gives; next, 'Questioner' may have a diseased queen; of twenty-one received for dissection three were so; and lastly, I have given a plain, unvarnished account of my own experience, and I only wish to exactly repeat, I am far from saying, however, that we have arrived at the bottom of the matter. I took a totally new departure last June, and the season was gone in thirty-five hours could be done. That brood has certainly been less tractable of late than in the spring; and in addition to my six different forms of *bacilli* previously announced, I have now several others, so that here my prophecy is fulfilled to the letter.

The whole question which I had the honour of initiating has grown immensely, and in my seasons any more work may be needed to clear all up. I am looking forward almost with impatience to the coming spring to recommence experimenting, and Mr. Watson Cheyne, in the interest of science, has declared his intention of working at the subject too.

Here our Committee will kindly, I am sure, undertake the extremely useful work of providing me with these intricate diseases, and then I feel I shall be the first to make the acknowledgment, and among the first to endeavour to discover why failure has occurred, and in striving to convert a temporary disappointment into a stepping-stone to success. —FRANK R. CHESHIRE, *Venue House, Acton, W.*

#### FOUL BROOD.

During the latter end of July I observed that three of my bar-frame hives were affected with foul brood. I was a little puzzled what to do, as I never had had any experience of nor had I seen the disease before. However, from the confident way in which Mr. Cheshire spoke of his phenomenal cure, I resolved to try it, and as honey was still coming in, I had to pour the medicated syrup over the brood-combs; but as soon as the gathering of honey ceased, I extracted all the combs in my apiary and commenced to feed; and after a little experience of it, I found that I in 600 was as much as the bees would take. When enough of this had been deposited and sealed for winter stores, I made a thorough examination, and found that it had not cured a single one, but the disease had spread to others that were being fed with the carbolicised syrup. I then withdrew the combs from two of the worst, and gave them empty ones to begin in, re-fed them in 600 of Calvert's No. 1; the disease spread again, and I lost all faith in the Cheshire cure.

I then got a salicylic acid fumigator, made flatter at the nozzle than the Bertrand, for easy insertion to the hives. After a little trouble with it, I managed to get it to draw, and had all my hives fumigated twice a-week with the most happy results. I could show at the present time patches of healthy brood in hives that were very bad when I commenced to fumigate. I have only one hive now showing a little of the disease, but I will not put it up for the winter until it is purified.

All my combs that are stored have been disinfected with chlorine gas. I put them into a close box and disengage the gas from chlor. lime with sulph. acid. I have proved this gas to be a more powerful disinfectant than sulphurous acid. From all my hives that had not brood in the combs I removed the bees, fumigated the hive, quilts, and combs with chlorine gas, and after twenty-four hours returned the bees.

If bee-keepers could be instructed where the disease exists, and only procure their appliances from those whose apiaries were in a healthy state, much less of this troublesome pest would exist.—VERITAS.

#### HEWITT'S FRAMES: A USEFUL HINT.

Now that bees are snug in winter quarters, and all the odds-and-ends are collected together and arranged in proper order for next season, is the time to begin building your own hives. The one who constructs most of the things he requires is the one who cares most for his bees and derives the most profit and pleasure from them, for while they are pesting he is employing the long winter evenings preparing new habitations for their occupancy the coming season.

Those who have never made a hive should begin at once, and take my word you will never buy another. I include the ladies as well, for, judging from the letters I have received, there are quite a number of such amateur hive-makers already. I believe no hive will be found so suitable for all purposes, or so easy to make, as the 'Excelsior' hive, described in the *Journal* this year on pages 68, 103, 157, and 184.

A word about the frames I offered to supply on page 185. Association 'plain' and 'wide' shoulders are 18, 4d per dozen; my frames ditto; double shoulders (to interchange with metal-ended frames), 15 $\frac{1}{2}$  inch top bar, 18, 7d. per dozen; 17 inch ditto, with ends painted, 18, 10d. per dozen. Any other odd sizes cut at 3d. per dozen extra, including the right kind of nails. All frames sent post free for 6d. per dozen more. Thus it will be seen I will let all have dovetailed frames (which any one can put together without using a block), double-shouldered for the price, or less, of metal ends alone; and as I am doing this entirely in the interest and to encourage amateur hive-making, I do not want all to get their hives ready and then come swarming altogether for the frames, just when I am too busy with other matters and my own bees, and cannot attend to what is wanted. So, taking a hint from this year's experience, I have decided not to execute any order for frames received after April until November; neither can I promise to supply late orders, though I shall if possible. The rule will be 'first come first served'; so, as the frames cannot lose any value by getting there in time, take the hint and be early. By so doing you will enable me to supply you all, and thus make the affair a 'help one another boys and girls.'—JOHN HEWITT, *Sheffield*.

#### HUMBLE BEES FOR NEW ZEALAND.

The above heading always recalls my boyish days, for at that time I was quite expert in 'spotting' a humble bee's nest, and I believe I carried their cultivation beyond anything considered possible. I was very fond of honey, and during the summer I could have all I cared to eat

—sometimes 'extracting' the honey every day. The greatest 'take' I ever got from one nest was a half of honey-comb, and the short space of time in which the bees replaced the honey removed was marvellous.

The Rev. Geo. Raynor names some of the difficulties in getting these bees to New Zealand, and Mr. Alfred Neighbour names the small amount of success after all his trouble. Well, as I consider (without the least disrespect) those who are trying to get these bees over there are entirely at 'sea' regarding the natural history of them, only to be compared to pre-Fluter times regarding hive-bees. I will give some of my observations bearing on the matter, for I do not believe a single queen landed there in February will ever make a nest.

In March, during warm weather, a large black humble bee, which I will call No. 1, may be noticed flying along banks and hedgelines, searching, not for honey, but the entrance of an abandoned mouse-nest in which to set up house-keeping; this bee has a light-coloured patch on its stern end.

In April another bee comes forth, which I will call No. 2; the only difference between it and No. 1 being a trifle smaller and has a red, instead of the light patch on its posterior; its habits are exactly the same, always choosing a mouse-nest in which to make its home.

In May a very different one makes its appearance, No. 3; this bee is of a brown colour and always makes its nest on the surface of the ground, which it constructs itself, —not unlike a mouse nest. This bee coming out of winter quarters two months later than No. 1 never becomes a large family, though I used to like them because their nests never had to be dug out.

I once found a family of No. 1 in a wren nest, and this is the only exception I ever met with of finding either Nos. 1 or 2 in other than a mouse-nest; so it is clear to me that if no mice or some small animal having similar habits do not exist there, it will be useless exporting either No. 1 or 2. Then again, the month of February there corresponds to our August, in this month the drones and young queens appear, which, as soon as mated, I believe go at once into winter quarters, so as to conserve as much of their energies as possible for the following season.

When a queen starts a nest I have never found her to rear more than five small workers—generally only three—allow only 21 days for these to hatch, 21 days for a subsequent brood, 21 days for the drone-laying bees and 21 for drones and queens, total 84 days without allowing anything for the wing state; what chance have they to establish themselves after February?

My opinion is, that unless they reach there the end of October, all attempts to acclimatize them will be so much wasted energy.

After June here, what queens do not succeed in finding the needed mouse-nest die off, it being then too late to establish themselves, or else they have worn themselves to death in the task of searching, nor do I think one queen in a hundred succeeds in being the mother of a family, even here. In July the nests are in the richest condition regarding brood and honey.

If I were the New Zealanders, I would turn my attention to No. 3; it is quite equal to Nos. 1 and 2 for working on red clover; and as their summers are longer, it would probably develop very strong nests; besides it is its own architect and builder, so it seems to be the bee for them. But the question is, how are they to be collected? Without wishing to be dogmatic, I think, if I had twelve months to prepare for the task I could literally load a ship with fertile dormant queens and deliver them in New Zealand on or before November 1st.

I do not know anything of any other kind of humble bees besides the three named, as no others are common about here. I have refrained from giving their scientific (?) names, as *Bombus terrestris* does not describe any of the three, though it is applied to at least one of them.

Mr. Raynor seems to think one has only to take the bees himself and be absent for four months during the winter to pick up 10000. I think a few particulars concerning the terms the reward is offered on ought to be given, as I do not think any government would be so stupid as to give a reward for simply landing a number of live queens, and I do not think any sensible man would take upon himself the task of delivering a large number of queens at the right time, and which subsequently established themselves, to run the risk of the money being handed over to someone else, who perhaps years before imported two live queens, which probably died, but which it was claimed were the progenitors of those subsequently successfully acclimatised. Judging from his reply, it is a hard matter to get rewards from governments, and when they are paid it is very often to the wrong party; so a few particulars would not be out of place, I think. JOHN HEWITT, *Sheffield*.

#### HUMBLE BEES FOR NEW ZEALAND.

Having written to the Agent-General for New Zealand *in re* the offer of 10000 for the introduction of humble bees, I received the following reply: 'The Agent-General has no knowledge of any offer made by the New Zealand Government respecting the introduction into that colony of humble bees. Several similar applications having been made, the Agent-General has referred the matter to the Government in New Zealand. Perhaps if you publish this in the *Bee Journal* it will elicit some useful information. B. FRAYMAN, *Eastbourne*.

#### MR. JACKSON AND THE B. B. K. A.

I thought when I penned my letter appearing in your issue of the 1st October, that there was a quarrel between you for the Parent Association and Mr. Jackson, but as both you and Mr. Jackson disclaim it, I fear I must have read the correspondence with a jaundiced eye.

I will, with your permission, devote a small space to answer Mr. Jackson and Mr. Little, and after that I will, as I promised to do, give you my reasons for believing that the counties of Lancashire and Cheshire cannot successfully be worked jointly.

In reply to my remarks about the Stockport Show Mr. Jackson gives many excuses, but no reasons for its poorness. My remark was that this Show was badly managed. I say so still, as Mr. Jackson's letter has failed to convince me to the contrary. As to the number of persons present at the Victoria, I have every desire to give Mr. Jackson credit for the fullest number; but I fear he draws on his imagination when he says there were from 100 to 200 present. The collaboration by 'Bellinger' (who is the expert of the Society) goes for little. Two friends totally unconnected with bee-keeping were present at the Show with me, and, having seen the correspondence, they say that both Mr. Jackson and myself are in error as to the numbers. They fix the number present at fifty. I will not split with Mr. Jackson even for fifty's sake. He can take them.

Mr. Jackson says that he hopes my next criticism will be better informed, as my reference to his hon. sec. at Chester is unfair. I criticised very little; I spoke of facts within my own knowledge and for the existence of those facts I did, and do blame the L. and C. B. K. A.; and if Mr. Little considers himself included in that condemnation I cannot help it. The place I referred to is almost on Mr. Little's doorstep, and yet his existence as connected with this Association is unknown. Mr. Jackson asks me if I am doing as much as Mr. Little. Mr. Jackson does not say what Mr. Little is doing, so that I cannot say. I may tell him, however, that I have, 'on my own hook,' as they say here, started one person in bee-keeping, and have two others ready for the

spring, and I am neither expert nor secretary. I suppose Mr. Jackson counts us in Manchester as 'out-of-barbarians,' but while thanking him for his offer of a cordial reception, I cannot, holding the views I do with regard to the L. and C. B. K. A., accept Mr. Jackson's invitation to join them. Let me disclaim the drawing of a 'red herring' across the path, whatever this may mean. My remarks were drawn forth by the correspondence between the *Journal* and Mr. Jackson, and by that simply. I had no ulterior object.

Poor Mr. Little! How indignant he is, and how he falls foul of me! He complains that I charge him with a neglect of his stewardship. No such remark occurred in my letter, nor did I call him a horse either willing or otherwise. I mentioned his name incidentally with his Association, and if he considers that he is responsible for the shortcomings of the Association so be it.

I may say that I did visit Mr. Little's establishment on a market-day, and I neither saw the poster (which you describe as 'effective') nor the crowds of bee-keepers waiting for advice. I certainly did not walk out into Eastgate Street to look for the placard, but sought the Row. The only things I could see relating to bee-keeping were some sections and a small quantity of bottled honey in the window. Mr. Little may have obtained four converts from Golden Sutton, but I think if he will visit Pufford, Poulton, Alford, and the district thereabouts, he will find considerably more.

Does Mr. Little really believe that the Duke of Westminster, as President of this Association, is to blame for the ignorance of his tenants on bee-keeping? If Mr. Little is sincere in his suggestion, then he has a very different notion than I have of ornamental presidents. Against Mr. Little, personally, I have nothing to say. I accept his statement that he is working hard for the Association, but all the same I think that his energies would be better seconded and produce better results if he would persuade Mr. Jackson and others to amalgamate with the B. B. K. A.

I will conclude this letter, which has extended to an undue length by giving as concisely as possible my reasons for saying that the L. and C. B. K. A. cannot be well and profitably worked under the present system of management. I quite agree with you that one county is amply sufficient for one Association to work successfully. I would go further and say that some of the larger counties, *eg.* Yorkshire and Lancashire, would be better served by being subdivided. This, however, is more a question for the consideration of the various County Associations *inter se* than for discussion now. But the L. and C. B. K. A. have acted on the reverse of this principle, and instead of subdividing one county have amalgamated two. They work their Association from Liverpool, the most unsuitable centre in point of position. From thence to the most northerly point of Lancashire is sixty-five miles, and to the most southerly point of Cheshire forty miles. This gives 105 miles as the crow flies north and south over which the Association must extend its supervision. The distance to the most easterly point of Cheshire is again forty-five miles, and the towns and villages thereabouts are difficult of access from Liverpool. The area of Lancashire is 1905 square miles; of Cheshire, 1101 square miles; thus giving 3006 square miles to this Association. The acreage of the counties is—Lancashire, 1,219,221; Cheshire, 757,978, a total of 1,976,200 acres. (Let me say that these figures showing the mileage and acreage are taken from different sources, and I have not the time to check them one against the other, but for all practical purposes they are correct.) The population is, of Lancashire, 3,454,411; of Cheshire, 644,037, a total again of 4,098,478. Take it for granted that only a small portion of the population is devoted to bee-keeping, these persons must necessarily be spread over a considerable area; and even then I say that the figures are

stupendous, and far beyond the ability of any one Association to successfully and profitably cope with. I can only conclude reiterating my former statement that the L. and C. B. K. A., will be healthier and more vigorous by adopting your advice working each county separately and amalgamating with the B. B. K. A. When this event happens, I promise them that if my help is worth anything they shall have it with all my heart.

I must apologise for the space I have taken up.—  
THETA, *Withington, near Manchester, Nov. 1884.*

#### A BEE-KEEPER'S EXPERIENCE.

Since your issue of the 1st inst., containing my letter of above heading, I have received numerous letters asking me what hives I use and how I work them; I ought also to acknowledge with gratitude the promise of a hive of bees in the spring from Mr. George Hallam, a fellow exhibitor at Tunbridge Wells. I believe there is nothing new in my method, and as they are mainly due to availing myself of the varied 'experiences' made public in the *Journal*, I feel it my duty to make them known through your pages.

1. Hives: 10-framed, frames across entrance, Dines' (of Maldon) pattern, *but the fillets overlap hive 1/2 inches.*

2. Supers: 10-framed, two inches between centres of frames. These frames of empty comb saved from year to year.

3. Bees: English blacks. Can it be that those who spoke of Abbott's large-celled foundation made a mistake? I ran short of foundation last year and used some of that in stock hives for swarms. A common remark of visitors here has been, "What large bees!" I believe that the size was due to the foundation being large-celled. Whether or no the breed is improved by increasing the size may be an open question, but these bees certainly did the best amount of work for me. Possibly, as Sussex labourers run large, I may be prejudiced in favour of large-sized 'workers.'

4. Method: Don't disturb brood-nest if doing so can possibly be avoided. Don't take out any honey from the two front frames; nor from the hive at all except from the two back frames. These, when extracted from, if of worker pattern, may be placed one on either side of the centre frame, *once* only and that in June, after the first harvest. After that date leave stock hive alone, and extract only from the frame or sectional supers. Prevent swarming by adding a second super, framed or sectioned. Take care that the supers are placed in opposite direction to the frames of the stock-hive. Feed early in March with thin syrup, into which the white of one egg and the yolks of two be well beaten up in each gallon, and a pinch of *salt-petre* added. Before going to a hive take a teaspoonful of honey into the mouth and slowly swallow it, allowing it to mix freely with the saliva. N.B. Be careful to wipe the lips well after. Use little, better say *no* smoke, but have smoker lighted and handy, as a weapon only. In middle of apiary place a broken pan, with a little leaf mould, and a piece of water-cress stalk in it. Fill up with water as often as needed. The cress spreads, keeps the water aerated, and gives a footing to the bees while drinking. Sugar-bags make good quilts. One the size of top of hive less 3/4 in. all round. Cut out from it the centre leaving the margin 1 1/2 inches wide. Sew over inner and outer edges. Another quilt same size as first, but with a 3-in. hole cut in it, a little to one side of centre, for feeding purposes. The piece cut out from No. 1 will do to place over the hole in No. 2, while a third quilt of same size as No. 2, but without a hole, will cover all three, and prove sufficient covering (in most counties) for the winter. If not deemed enough a chaff-cushion same size as hive-top, less 2 in. all round, will allow of ventilation all round, while the centre of hive will be very warm. The super minus its frames

and then the roof over all will finish the preparations for winter.

In extracting from frame super take out the full centre frames and replace *at once* with empty ones, or preferably with those from the outer side. *On no account let the bees seal over the super frames.* As there will be no uncapping, time will be saved, comb remain unmlagged and of its full thickness, and, above all, the bees will not weary or rest because they have sealed stores in super. The honey extracted from super will be thin. When extractor gets uncomfortably full (too near cage) store in jars for sale. Place these up to their necks in a fish-kettle of cold water, put clean but *course* cloth over the tops to the depth of two thicknesses, and raise water to *boiling point*, remove jars, skim, wipe outside, and with white of egg, or gloy, brush the *outside* edge of the rim. Put on damaged vegetable parchment, tie down and label. As the honey cools the parchment will draw in a little and make a more perfect fastening than can otherwise be got.—THOMAS STOTHARD, *Pagham, Bognor.*

P.S. I ought perhaps to say that the method followed was under peculiarly advantageous circumstances as we are south of the Downs near the sea, and last season had quantities of clover grown for seed close by.

#### EDITORIAL IGNORANCE.

The following 'leader' from the *Evening Standard* of October 9th, ought to hearten up those bee experts who have of late been thinking the demonstrations in the bee tent were being overdone, and that the whole British public was by this time well acquainted with the art of bee-mastery. There is at least one person in a responsible position who evidently knows nothing of the vast labours now going on in England to educate people in the art, and it is instructive reading how our pupils across the Atlantic are causing wonderment, if not incredulity, to those who have, at all events, had an opportunity of witnessing the same thing here any day during the last ten years. Let us, therefore, redouble our exertions, and whenever opportunity occur, invite specially our masters the editors to witness our 'amazing leamery,' so that the 'gauze tent' and its wonders may at least be ascribed to the proper inventors. It is not so long ago that the *American Bee Journal* gave a full description and plate of what a British bee tent was, with, if I remember rightly, the expression of a hope that a similar construction might one day be adopted in the United States.—E. H. BELLAIRS, *Hon. Sec. and Professor to the Haunts and Isle of Wight Bee-keepers' Association.*

"A good many persons stand in fear of bees, for the sting these busy little insects can inflict is always painful, and may even in some cases be really dangerous. According, however, to an American professor, who recently gave a rather remarkable entertainment during the State fair held at Philadelphia, everything depends on the way in which bees are handled. In proof of his theory he entered a tent swarming with bees, and, quite unprotected by head net or gloves, opened an old hive full of bees, took out each comb and transferred it to a new hive. He further sought out the queen-bee, and having caught her, exhibited her to the spectators outside his gauze tent previous to placing her majesty in a handsome home prepared for her reception. The professor manipulated the insects with perfect indifference to the fact that each one was provided with a weapon of defence, and appeared to be on such good terms with them that no notion of danger could be entertained. "The bees," says the American paper, "crawled over his bald head, swarmed up his hands and arms, entangled themselves in his long beard, and seemed to enjoy the whole thing as though it were excellent fun and play." The public, looking on through the protecting curtain of gauze, were simply amazed at the temerity of the professor, who remained for a considerable time in the midst of the crowded insect colony, and came out of the tent unharmed."

## JAPANESE BEE-KEEPING.

The following extract from a letter of my husband, just received from Japan (Nagasaki, September 14th), may interest some of your readers. It is evident that, though not very far advanced in the art of bee-keeping, the Japanese are yet wiser in some ways than many of our cottage bee-keepers in remote country districts still unvisited by kindly teachers and helpers:—

"I must also tell you about the bees. I went out with the consul, Mr. Hall, in a "jinricksha" to a Japanese house in the suburbs. In the garden were several little boxes, about the size of a soap-box, 2 by 1 foot square, placed on end on posts, and covered with a straw cap to keep off the rain. The boxes were sufficiently off the floor-board to allow the bees to enter all round instead of by a single door, only the front had a large alighting board, and the bees evidently understood that this was the front of their house. They were clustering thickly all round the lower part, and even up the side, as if the hive was far too crowded; and the owner explained that they kept outside like that to be cool, but that if it came on to rain they would

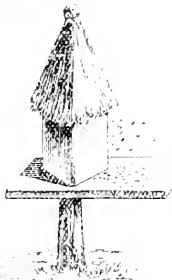

all go inside. The bee is very small, lighter in colour than ours, and striped like a wasp. I saw no drones, and on asking questions, soon saw that the owner knew nothing of the interior of a hive, as he spoke of there being several parents inside, and he had never heard that the drones were killed off by the workers towards the end of the season, nor of queens being brought up, nor any details in fact. He was very much surprised when I described to him a bar-framed hive, and the improved system of management in England. In October they stupify the bees and take half the honey, which they say is in the upper combs, and leave the other half for the bees, which is quite sufficient for them. *They never kill the bees.* When I explained about driving bees, the man said it was as much as his life was worth to try and shift bees from one hive to another—a swarm, yes—but bees from an old hive? never! I had to talk through the consul, who, I believe, speaks Japanese well, though not perfectly. It was quite a treat to see the little bees again! J. M. CLAYTON, Cranleigh, near Guildford, November 1st.

## SPLIT TOP-BARS.

Until I read the letter of A. Clayton on p. 385, telling how to fix foundations, I was under the impression that my plan of fixing it by means of the wax-spoon described on p. 185 had finally solved every difficulty and that split top-bars were now out of date. Wherever I go, I mostly find the spoon in use, and every one seems delighted with it and declares it to be the best thing out for fixing foundation; amongst other testimonials privately sent me, I extract from one the following remarks: "For the first time I have found putting in foundation a pleasant task, and a very rapid one, I wish I had had them before. . . . Now that I have got your spoons I shall split no more top-bars." There is a lady on p. 206, who describes it "perfection," and that it removes "one of the trials of bee-keeping."

Besides the fact that split top-bars waste from 5 to 30 per cent of foundation, I have had very painful ex-

perience of the evil of splitting tops and letting moths in from above; for years I have been in the habit of storing all spare combs in gin-case hives, and in addition to putting in a lump of camphor, fastening all up 'moth-tight'; I had one box of combs with these tops, in which I expected moths to appear, but though I considered it impossible for moths in the wing state to get into the other boxes, I found the worms could eat their way in; they got into *everything*, destroyed even foundation, and made holes in cakes of wax; two boxes which had been in store over two years and which were quite sound last Christmas, were all one mass of moths and *debris*, not a single cell left. I lost in all about 130 beautiful combs, besides my trouble of trying to save them, at a time when I could ill spare the time,—so much for putting away half-a-dozen of these tops.

Let me ask all advanced and practical bee-keepers to come forward and defend them *if they can*, for I am inclined to think I would rather have fool-proof in a hive than bars with these tops. I may say it is with feelings of satisfaction that I have given them their death-blow by means of such a simple thing as my wax-spoon, which any one can make for himself. JOHN HEWITT, Sheffield.

## A HONEY-BASKET.

A want, as far as I know unsupplied, is a honey-basket for sending three or five pounds of honey by Parcels Post. There are flower-baskets and other devices for sending flowers by Parcels Post; a cheap honey-basket would in this prolific year have ensured a ready sale.—A. B. HARRISON.

## HOW I BECAME A BEE-KEEPER, AND SOME OF MY EXPERIENCES.

In the early part of 1878 I chanced to get hold of some old numbers of the *Journal of Horticulture*. If my memory serve me right they were about the year 1861; to my sorrow they have since been destroyed. Then, as now, foul brood had made sad havoc in some districts, amongst others the apiary of the late Mr. Woodbury subaltern. The discussion carried on attracted my attention to bees, so I eagerly read up everything concerning them; amongst other manuals, *Bee-keeping for the Many*, by the late Mr. Payne. At Michaelmas, 1878, I purchased my first stock, domiciled in a rotten old skep. I paid for them in gold to insure luck; but unfortunately for the said luck, the next day I got my first stinging lesson. I determined to use Payne's skeps. The following year, 1879, was very bad; I only got one swarm, and had to feed heavily. But in spite of my care when the spring arrived my old stock perished. I think had it been on a separate floor-board I should have saved it, but it was stuck to the block with clay and so rotten that I dared not move it (by the way I may say that this was my first and last loss). But to proceed. In May I bought another swarm, which, with my own increase, enabled me to commence (1881) with four stocks. About this time I first heard of Bee Associations and the *B. E. Journal*. I got one of Mr. Abbott's old catalogues and *Modern Bee-keeping*, with the information derived from them I determined to make a frame-hive, drive the four old stocks, appropriate the honey, transfer brood combs to my new five frames 16 by 10. Up to this time (Aug. 1881) I had never seen any one turn a skep over in broad daylight, much less to drive or transfer; but muffled up in veil and gloves one fine afternoon I made the attempt, and got through the job successfully in about three hours. My take of run honey was about 100 lbs. I believe I did not get a sting. I transferred my bees from the four stocks and all the brood into the frame-hive. My feelings, two or three days afterwards, when rolling back the quilt to take my first peep and

remove the tapes, can be better imagined than described. When the little things clambered up to the top of the bars and peeped out between the combs at the blue sky, my thoughts ran, 'What next?' particularly as an old bee-dame, who stood a few yards distant, kept exclaiming, 'Well, I never! they'll give it to be presently!' However they did not, which established my reputation with the old lady as one who knew all about bees. Before the autumn set in I had the opportunity of visiting Mr. Abbott's apiary at Southall; whilst there I saw him open the Hive for Advancing Bee-keepers, which came in for a full share of criticism about that time. There I saw the first frame-hive other than my own. Likewise the first expert in the person of Mr. A. Since then I have seen many, but I have yet to see his equal.—at least I think so. I know it is said first are lasting impressions; it may be so with me, I certainly came home much edified. In the spring (1882) I made four Copyable hives, and when swarming time came removed them to their present position alongside of the line away from a roadway, where I feared they would be a nuisance. My honey productions for 1882 were not large, as increase of stock and the sale of bees kept them necessarily weak. The spring of 1883 found me with four stocks in frame-hives. During the season I increased to fourteen, and sold two swarms, one queen, and 120 lbs. of comb honey. I did not extract from body of hive as I have not much time to extract and afterwards to fuss about feeding. Before I close I would like to say that the reading of papers at the Quarterly Meetings of the B. B. K. A. and the discussions which follow are truly a boon to cottagers, as everything in connexion with the subject is brought out by the great masters far better than an illiterate cottager like myself could do if we questioned the lecturer privately. If I might be allowed to express an opinion, I would like to hear a paper read on the 'Advantage of selected eggs for queen-rearing,' *i.e.*, raising all queens in the best stocks. I believe the queens I have raised the last two seasons are far more prolific than I ever had before; in fact, better than many I have seen where no such selection is practised; but then you know every one thinks their crow the blackest; and in truth, sir, I love my bees.—THE PLATELAYER, *Rocking, Ashford.*

#### BEE FLORA: A SUGGESTION.

Among the many good and useful works on bee-keeping and bee-farming, I have not yet seen or heard of a good book on bee flora; if there is no work of the kind, I think it would be a great boon to bee-keepers, especially to those who have ground and who keep bees for profit, if some one who is well acquainted with bees and bee flora, would take up the matter and get a really good and practical work published on the subject. Such a work might treat of fruits, flowers, trees, and shrubs, their nature and culture and value as honey producers, and the time of year they would be of most service to the bees. Hoping that some of our practical gardeners and botanists, who are bee-keepers, will take up the subject, for I believe such a work would have a large sale.—D. H. D.

#### NOTINGS FOR THE JOURNAL.

I notice that 'Icarus's' contribution regarding the frequent flight of queen-bees is contrary to the usually received opinions. As an additional fact, supporting the above, another ingenious friend made an observatory hive after a book pattern, each frame opened out, and separated by glass into compartments; you could read all about the bees in fine style, inspect her majesty, and see all the secrets of court life. By-and-by her majesty disappeared and could not be found in any of the com-

partments. After some days of suspense my friend added another queen to the observatory hive, and judge of his surprise to find in a few days that this one also had disappeared. A careful search failed to find her. The hive opens on to a very smooth varnished alighting-board, at an angle of about 45 degrees, to run the wet off. Now one of two things must have happened in her flights; her majesty must have been unable to come up the smooth alighting-board, or else failed to find her way to the proper compartment where her attendants expected her.

*Vagaries of the Honey Season.*—It is rather tantalising to read and hear from all around glorious accounts of the honey season, and to know that a wee bit of four or five miles around one's apiary has been, until the heather commenced, a complete failure. Why, within the radius of what I have mentioned, I found several swarms dead of starvation. Certainly bee-keepers are a hopeful set, and look upward and onward towards future success.

The heather with us having been very fine two of my heaviest hives, weighed at the railway station, brought down the scale at 17 stone the pair. Then we have had, under the patronage of Lady Downes, of Danby, an exhibition of honey in connexion with her ladyship's agricultural show; the honey exhibited being very fine indeed, both in sections and caps from skeps, run honey, &c. The first prize was taken with a very fine cap from a straw skep; the second a fine lot of sections, the first in run honey, by a sample of bean or clover honey, which ought to have been classed by itself; a lot of very fine samples of golden honey from the heath being also exhibited.

In the question of sections, even friends who do not swear are tempted to say something strong, as a relief to their feelings, when they find that in endeavouring to replace full ones with empty ones, they are of different sizes, and will not fit anyhow. Can we not have something uniform indicated by Nos. 1, 2, 3, &c., not those of all sizes which fit no place until all the corners are rounded off—and fancy having to do that with a pocket-knife, as I heard a lady bee-keeper had to do whilst visiting her bees on the moors! A man would have been out of all patience, and condemned the maker and his sections to eternal perdition.

I am glad to see the question of foul brood—I beg pardon, *Bacillus aberi* (Ugh!). It will take a set of false teeth and an additional piece on to the tongue to properly pronounce that big word. I have met two cases resulting from chilled brood, by the hives being overturned during last winter, and the cluster shifting and not being able to return. Two other cases I have met, evidently infection from one of the preceding cases. A friend purchased a bottle of the Cheshire cure, price 1s. 6d., and carriage extra. I have been wondering how many bottles it would take to cure a stock, and whether the cure is not more expensive than the disease. As it is given so freely as a specific, why not tell poor bee-keepers, more especially those who cannot afford to buy those 1s. 6d. worth, that pure phenol can be had at 5s. 6d. per lb., which would make 100 lbs. of stock solution, and would fill about 500 of those bottles? I do not begrudge a fair percentage, but this is over the usual 11 $\frac{1}{2}$ d. to the 1s.\* Cannot bee-keepers be generous and discard trade interests in a matter like this, and earn the thanks of poor people if they have any thanks to give? Simplicity is a law of nature, and to those bee-

\* You are in error altogether. 1 lb. of absolute phenol hydrated as it is sold by Mr. Lyon or Mr. Hollands, will make less than twenty bottles. The object of Mr. Cheshire has not been to make profit, but to save bee-keepers from a spurious article. We know, indeed, that he has devoted an enormous amount of time to, and has incurred very heavy outlay in, the prosecution of the investigation, for which he has (not being a trader) no possible hope of return.

keepers who have hives affected with foul brood, why not place a few crystals of phenol on the bottom of the hive, and allow it slowly to deliquesce when it ought to permeate every nook and cranny of the bee-hive, and give a cure pure and simple?

Another good thing for the benefit of all bee-keepers might be undertaken by the B. B. K. A., that is, to devote a fund to pay any person the necessary outlay in bringing forward and publicly presenting spurious honey-colours in every town in England. Since the prosecution in Glasgow it is not so freely sold in Scotland, and after that event even some of our local growers withdrew the abominable mixtures; but as in no other case was brought forward they are now again exposing it for sale. It would only be necessary to bring one or two to justice, the rest would take the alarm and cease imposing glaucose upon the British public. Suppose every bee-keeper sent 1s. to the B. B. K. A. for the express purpose of defraying the costs, it would be a good stroke of business for bee-keepers.

Bees appear quite settled down for the winter; in many cases packing themselves quite close. We are inclined to wonder at this so early, after having them on the wing up to last Christmas.

I see from October *Journal*, 'Ubique' wishes to know if building out comb and string syrups will wear out tissue and waste bee-life. My experience is that it does so to a large extent, so much so that all driven bees this season have been put on to sealed combs. The same writer expresses the intention of uniting bees under the influence of chloroform; from many years' practical experience, both on the *genus Homo, Canis, and Apis*, I can only say, 'Don't!' the chances are ten to one that the bees will unite for all eternity. W. Crisp, *Great Ayles*.

DIRECT QUEEN INTRODUCTION. Mr. W. D. Slade, Cheltenham, writes: 'Regarding the correspondence on the above subject, I wish to remark that in August last I safely introduced three Italian queens to black stocks (not parading on their own combs, but simply dropped from the box they arrived in between the frames alone, unaccompanied with any bees, in one case without using any smoke. All have done well, and are now strong stocks full of brood. I give this testimony with plausibility, as being but an amateur bee-keeper, and one who owes much to Mr. Simmuis for his kind and courteous assistance at all times so readily rendered.'

Mr. L. Wren, of Lowestoft, writes: 'Introducing a queen by wing rather than by Mr. Simmuis' method of direct introduction is about equal to sending a message through the post in preference to a telegram. I have introduced a large number of queens direct, and only remember one failure, and that through my own inattention; if I have no bees with a queen I generally smoke the entrance in the evening, let her run in, smoke again and leave them, I have not lost a single queen introduced in that way.'

Mr. Thomas Isaac, of Maldon, Essex, writes: 'I have introduced a Bignonia queen to a black stock, on the plan recommended by Mr. Simmuis, and it was a perfectly successful experiment.'

LECTURE ON BEE-KEEPING. On Monday evening, October 27th, under the auspices of the Marlborough College Natural History Society, Mr. W. N. Griffin, Hon. Sec. to the Devonshire Bee-keepers' Association, delivered an able lecture on 'Bees and Bee-keeping' at the College. There were nearly one hundred assembled to hear the lecture, the majority of whom were students. Mr. Griffin dealt with his subject, and answered various interesting and critical questions in a masterly manner, and at the conclusion the President of the M. C. N. H. S. tendered the best thanks of the meeting to him for his practical and instructive lecture.

## NOTICES TO CORRESPONDENTS & INQUIRERS.

MORRIMER, Tom.—*Robbing*.—There is little doubt but that your hive was robbed by one of your other lots. The empty combs will do to put to another swarm next year, provided you preserve them from moth. Why not transfer the empty comb to a bar-frame hive, and give a swarm in it?

Q. Q. Q.—*Queen-rearing*.—1. For queen-rearing we should prefer the nuclei on separate stands. When raising queens in nuclei there is little danger of robbing, since the operations are performed during the honey-flow. For security, while introducing queens and other operations, Mr. A. I. Root, of Medina, Ohio, U.S.A., has brought out a small tent the length, height, and width being each 5 feet, which is placed over the hive during manipulation, an illustration of which is given in his last edition of the *A. B. C. Guide*. It folds up in small compass for carrying about; weighs 6 lbs. only. The price is 1½ dollars—about 6s. 3d. sterling, and it is covered with mosquito netting. Nuclei should never be examined while the young queens are out on their wedding flights—generally between 12 and 3. Morning and evening are the best times for examination. 2. *Lamp nursery*.—Yes; we should adopt the 'lamp nursery,' which Mr. Root supplies complete, with lamp and cone, to burn for several days, for 5 dollars 2½s. Mr. Dadtlett's method, to which you refer, is merely a plan for *uniting* nuclei in the autumn, not for *queen-rearing*. It is given fully in the *American Bee Journal*, for October 22, 1884, p. 3. *Winter Supply*.

All colonies ought to have been well provisioned for winter long before this time. You can now only give candy over the frames. It is worse than useless to supply water at this season. 4. *Winter Packages*.

Winter packages are quite sufficient without sticks over the frames. 5. *Entrances to Nuclei*. If you do not wish to rob a house for your nuclei, the entrances should not be made to each other than three feet, and the lower row should be about the same distance from the upper, each entrance being painted alternately light and dark. Two rows will be sufficient. 6. *Wood for Bee-houses*. Good, sound, white deal, if well painted, is as good a material for bee-houses, and for the hives to stand inside them, which should not be painted. Yellow deal, pine, &c., are recommended for hives standing outside, with no other protection. The other timber you mention is not suitable. 7. *Forming Yards*. No; the bees would not remain. The old plan of forming nuclei is best. 8. *Marking Entrances to Yards*. The glass would be useless in this case. During the swarming fever the attachment of the bees to their queen is so strong that your proposed plans would most certainly fail.

V. A. W. CONYER, 1. *Queenless Stock*. It is very doubtful whether a queenless colony would fix transferred combs and store syrup. We are inclined to think they would not; certainly not at this late period. If you possess such a colony, by far your best plan is to unite them to another, first having transferred them, and then placing bees and transferred comb on the outside of the colony to which they are to be united without smoking or disturbance of any kind. The operation should be performed either in a moderately warm room or on a very mild day, and the hive covered up as quickly as possible and returned to its stand. 2. *Stagnant*. No; bees do not extract poison from sun-flowers! Your bees were chilled by cold. 3. *Number of Bees needed with Honey to fill an ordinary Brood-cell*.

We do not know; but you may easily make a calculation, seeing that in an average season a bee collects about one teaspoonful, or 60 drops of honey. The other data required will be the size of an average cell, the number of journeys made by the bees, and the quantity of honey contained in its sac. It will be remembered

that honey-cells are usually much elongated—some more, some less—so that an average depth of cell must be taken.

BERNE.—It is not necessary or desirable to paint the inside of hives.

C. N. WHITE.—*Microscopes*.—No microscope that can be really recommended would cost less than *5l. 5s.* An instrument at this figure is supplied by Messrs. Beck, 31 Cornhill, London, or Swift & Son, 81 Tottenham Court Road, both of which are excellent. They have no adjustment, but the body slips in a tube lined with velvet, and a very smooth and manageable movement is thus obtained. The fine adjustment is of the ordinary kind. They have 1 in. and  $\frac{1}{2}$  in. objectives, and are put into convenient mahogany cases. We should write for the catalogues of each of these makers, perhaps adding Browning, 65 Strand; Baker, 244 Holborn; and Crouch, 66 Barbican. If you buy a second-hand microscope and wish to add powers (or 'objectives,' as they are called) we should earnestly say, Try Beck's  $\frac{1}{4}$  in. at *1l.*, which is a really good lens, and better than one costing us *5l. 5s.* a few years ago. All ordinary work can be accomplished with the instruments above named. By properly managing the light, which is a most important matter in microscopic investigation, they are competent to determine the presence of foul brood and show the living swimming *Bacilli alvei*; but for special critical work the microscope should be provided with a sub-stage, and have an achromatic condenser and powers suited to the nature of the investigation in hand. The catalogue of the makers named will here give all needed information, but for highest-class objectives write to Powell & Lealand, 170 Easton Road, London. Beside your microscope, you will require a watchmaker's eye-glass, which we fix round the head by a tape, and just push up on to the forehead when it is not at the moment needed. This will cost *1s. to 1s. 6d.* With the addition of a few slips of glass,  $\frac{3}{16}$  in. by 1, some thin cover-glasses (of which  $\frac{1}{4}$  oz.  $\frac{3}{16}$  in. squares, costing *1s. 3d.*, will be quite a stock) and a few needles set in handles, you will be set up. One or two of the needles should be made red-hot, hammered flat, then hardened and sharpened as knives. Add to these, a bottle of violet and red inks as stains, and determinations of nerve-structures, muscles, &c., will be within your grasp, and afford endless enjoyment. We are contemplating an article on the best means of roughly or carefully dissecting bees for examination. The lens mentioned by Cook, page 51, is, of course, American. Browning, whose address is given above, makes one much like it, which he calls the Orthoscopic. Its cost is about *18s.*, but it is valuable in dissection only. It is useless for investigation, the watch-maker's eye-glass being nearly equal to it.—F. C.

C. L. H.—Thanks for calling attention to the matter. We shall refer to it shortly.

G. D. CLARK.—*Combs bespattered with Propolis*.—Propolis is not of a nature to spatter. We should feel inclined to think the marks were those of dysentery. Can you send us a small piece of comb in a box so as not to be crushed in post?

THOS. MORGAN.—1. *Moving Stocks eighty Yards*.—We should wait until the weather is less open than at present. Do not stop the entrances, but put a board leaning against the hives, so that the bees when going out may notice the unusual aspect, and so mark the new position. 2. *Market for Honey*.—Refer to our advertisement columns.

M. HALLEWELL.—1. *Candy*.—If you fear your stocks are insufficiently supplied, lay a piece of candy on the frames under the quilt. You will find it a better plan than placing a large slab in a frame at the side of the hive, for reasons too long to enter upon here.

2. *Bees Cleaning*.—As they remove the vitiated air from the hive fresh air enters to take its place. The current is so gentle that no danger exists of chilling the brood.

ANDREW BUCHAN.—*Hives for the Heather*.—You do not say what bar-frame hives are in use in your district. But, presuming they are the Standard size, probably a shallower frame, more approaching the depth of the combs in the Stewarton, would be better, as being less liable to breakage of combs in transit to the heather, and offering greater facilities for obtaining the honey in sections.

W. H. J.—*Doubling*.—There should be  $\frac{1}{4}$ -in. space between the bottom bars of the upper frames and the top bars of the lower. When separating the two hives for extracting, a wire should be passed between them, after *very slightly* wedging up the upper one. The zinc excluder, lying close upon the frames of the lower hive, will be securely fastened by the bees and will remain a fixture during the extracting period. The top bars of the frames must be 'flush' with the hive sides.

MATILDA.—*Removing Sections*.—It would have been better to have removed the sections, but we advise you now to allow them to remain. The disturbance caused by removing them at this late period would be most injurious, and might prove fatal to the bees, if the weather proved cold or frosty. Cover them as warmly as possible, and when spring comes you will probably find the sections consumed. Prevent all draught through hive and sections.

E. HIND.—*Storing Combs*.—Stow away your combs, wrapped up in paper, in a dry room, until wanted for use next spring, when you will find them useful for swarms. When given to the bees they will soon clean them much quicker and better than you could do.

T. P. C.—*Paper for packing Trays*.—We have never used paper for the purpose you name, nor do we think it suitable. When torn into small pieces and pressed together it would become impervious to moisture and air likewise. There is no better material for packing 'trays' than corkdust or sawdust, and 'trays' of 6 inches in depth are quite sufficient for covering hives during the winter months.

C. O. MOON.—We should think that your stock is heavy enough for the winter.

T. W. LOFTUS.—You would get the information you require by applying either to W. P. Meadows, Syston, Leicester, or to J. H. Howard, Holme, near Peterborough.

ESSEX.—If you desire to have a stock of Ligurians with your blacks, we should advise to procure one. We are of opinion that Ligurians, if properly managed, are better bees than Blacks. A stock of Ligurians may be purchased for one guinea.

H. W. DAVIS.—1. You are quite right not to give syrup at this season. Your fault in making the candy was boiling it too much. Cease boiling when a little dropped into cold water will knead between the fingers into a ball. Then remove from the fire and stir until it begins to set. Turn into plates lined with paper. If properly prepared, it will not be very hard and crystalline, but rather soft and pasty, but opaque. You should remove the zinc and turn the candy down on the hole. Bees cannot eat or use crystalline sugar, therefore, it was thrown out at the door and this also caused the excitement. 2. The local secretary of the Surrey B. K. A., is Dr. Walker, Lingfield Road, Wimbledon; who will give you every information, and will be pleased to enrol you as a member.

MICHAEL QUINN.—The comb is badly diseased, and millions of spores are found in the bad cells. It appears to be *Bacillus alvei* of the ordinary type.—F. C.



# THE BRITISH BEE JOURNAL

Communications to the Editor to be addressed 'STRANGEWAYS' PRINTING OFFICE, Tower Street, St. Martin's Lane, w.c.'

[No. 159. VOL. XII.]

DECEMBER 1, 1884.

[PUBLISHED FORTNIGHTLY.]

## Editorial, Notices, &c.

### A VISIT TO LORD SUDELEY'S FRUIT PLANTATIONS.

By WM. N. GRIFFIN, HON. SEC. DEVON AND EXETER  
BEE-KEEPERS' ASSOCIATION.

Having had some correspondence with Lord Sudley with reference to his fruit-farm, and as I take a great interest in all the minor industries, while staying at Cheltenham a short time since, I paid a visit to Toddington, and believe I shall do well to send you a short account of what I saw during my visit.

In the present day, when agriculture is at such a low ebb, I should recommend to the careful consideration of all farmers—the example shown them by his lordship; and they might with advantage set aside a portion of their land to the cultivation of fruit, or pay a little more attention to their present orchards; at the same time, not omitting to keep bees, as, besides being in themselves profitable, they are absolutely necessary for the fertilisation of the fruit.

Leaving Cheltenham by an early train, I arrived at Beckford about 10 o'clock. This being a small village I had some difficulty in obtaining a conveyance, when, almost giving it up in despair, I learnt that a dairy farmer bearing the ancient name of Oldacre had one. Having succeeded in finding my John, we started. The road lay through pretty country, nicely wooded. Arrived at Toddington Farm, Mr. Laight, Lord Sudley's bailiff, first very kindly showed me how ensilage is made, and pointed out the five new silos which are erected on the home farm. Mr. Laight disbelieved in silos at first; now they have no firmer advocate. The building just erected is built of brick, against an old stone wall. It is divided into five compartments, separated by brick walls (the outer containing walls four-or-five inches thick), and all of them lined with cement; and each compartment is eight feet wide and thirteen feet high. In each case there is an opening at A, from which the silo is filled. There is a groove at each side of these doorways, and as the stuff is thrown in, and its level in the silo begins to rise, planks are fitted into the grooved doorway, one above the other, until the silo is filled to the top, and the doorway completely blocked by the planks. The method employed for compressing the contents of the silo is very simple. Two perpendicular bars of iron are firmly fixed at BB, the upper portion of each of them deeply wormed for a screw. When the silo is full, planks are laid length-

wise over its whole surface, through which the wormed ends of the iron bars protrude. Two joists are then laid across these planks at BB, the wormed bars coming up through the joists, and great pressure is exerted on

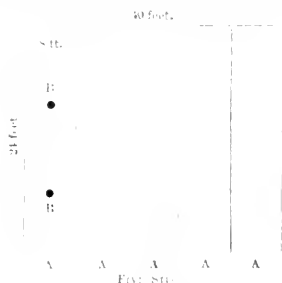

the whole frame-work by means of two iron nuts, worked with three long handles, and screwing on to the tops of the iron bars. It is found that a few turns of this screw every day are all that is required in order sufficiently to exclude the air, and so to compress the contents of the silo as to keep them sound and good. The cost of erecting these five silos has been 2037s., including between 2/ and 3/ for each iron screwing apparatus. When filled and pressed down, and duly covered with a layer of five inches of bran, spread over the lid of planks to exclude the air, each compartment contains about fifty tons of ensilage, it being remembered that the same hay which put in moist as ensilage would weigh fifty tons would, if dried and stacked in the usual manner, weigh only ten tons. Everything is chopped up before it is housed. No salt is added. About sixteen days after the filling of the silo the daily screwing down of the lid has reduced the level of the surface of its contents by about three feet. It is now opened, filled up once more to the top, and again carefully closed. After this the settling down does not amount to more than nine inches. In Mr. Laight's experience, clover and maize make the best ensilage. All cattle, dairy and store alike, eat it with avidity. He gives it them mixed with an equal quantity of straw-chaff, and never knew an animal refuse it. From experiments he has tried, he believes that it often is to reduce slightly the quantity of milk given, but very much to improve the quality of the cream and butter.

The cost of making ensilage for each fifty tons, including mowing, cartage, and turning into chaff, is

47. 2s. 6d. The possibility of preserving ensilage in small quantities in casks is a matter of great interest to small farmers, as very much that would otherwise be wasted is well worth preserving as ensilage. Mr. Laight intends to feed horses this year with it, as has been successfully done by Lord Walsingham in Norfolk; and it is not impossible that some day ensilage-grass may be a staple article in the food of our London horses. Its weight, however, will always be against it where the journey is long.

Driving through the Park we came to the jam factory, which is about a mile and a half distant from the farm. Here Mr. Beach, the proprietor, courteously conducted me through the works, which were originally a farmhouse, and I was greatly surprised at its extent, promising annually to increase. The whole product of Lord Sudley's fruit-plantations is purchased by Mr. Beach, the well-known manufacturer of Ealing, and for the most part converted into jam. The purity of the jams is a speciality of the firm, the highest awards having been secured by it for the excellence of their manufactures. The material for making the best of jams is obtainable at Toddington, for the fruit, instead of being packed and having to travel a considerable distance, exposed, for part of the time at least, to the heat of the sun, or perhaps wet weather, is here picked from the trees, carried at once into the factory, and converted while the bloom of freshness is upon it into jam.

The farm-buildings have been fitted up for the purpose of preserving fruit on a large scale, every effort being made by Lord Sudley to render the establishment as complete as possible. Even the baskets and hampers are made by his lordship's men on the premises, there being fourteen to fifteen acres of osiers planted on the estate for use in this respect. My first visit was to the boiling-room, where I witnessed the process of jam-making by steam. Attached to this room is a boiler of over 30-horse power. It is 22 feet long by 5ft. 6in. in diameter and weighs over seven tons. The works at present are not in full operation, but as showing the extent of what is now done, Mr. Beach has made over 150 tons of jam this year. In the strawberry season he filled 1600 jars, each holding 12 lbs. of jam, in four days. The fruit is boiled up in eleven great copper pans, into each is poured a jug of water and into the water 25 lbs. of white sugar, —best Dutch-crushed, as it is called, being a mixture of half-and-half cane and beet-root. (This year 30 tons have been used.) When the sugar is dissolved 24 lbs. of raspberries (to give an illustration), some of it gathered perhaps only an hour or two previous, was thrown in, and then the crimson mixture, foaming and bubbling under the heat of steam (50-lb. pressure to the square inch) from the great boiler is for about eight minutes stirred, and critically examined, with the aid of a long wooden ladle, till, being pronounced ready, it is run off into another copper and carried into the shed, fitted up with dressers and shelves, where it is adroitly transferred to 36 bottles, each now containing 1½ lbs. of the most brilliant raspberry jam. As soon as the air-tight covers are tied on, these bottles are ready to be despatched to the four corners of the globe. Mat-of-familias, who thinks that the proper way to make jam is to let it gently simmer for an hour or more over a slow fire, would be astonished at Mr. Beach's process and the rapidity with which the fruit is boiled. Connected with the engine are pipes leading to shells underneath the pans, so fitted that the steam cannot escape: these pans act on a kind of swivel or pivot, and when the fruit is reduced into jam, in addition to the method described, in some cases it is run into large pans and conveyed to the cooling-room. This plan saves skimming.

Another process is to boil the fruit without sugar, and when scalding hot to place it in stone bottles (each holding 40 lbs. of jam) and cork down immediately. In this way it will keep any length of time and be fit to make

into jam when required. This is called laying it down in pulp. By this arrangement, if the quantity of fruit received exceeds the means of reducing it at once into jam, it can be made into pulp, and utilised at leisure without detriment to the quality of the fruit, thus affording employment to the 'hands' during the winter. If fruit be over-ripe, in the least decayed, or gathered in wet weather, it will not make good jam,—a point on which Mr. Beach appeared very careful. Another fact which adds to the quality of Mr. Beach's jam is that the jelly is left in with the fruit. It was explained that when the growth of the plantations enforces it, the boiling-room will be considerably enlarged and that as many as twenty pans will be in operation.

Leaving the boiling-room, I was next shown the cooling process, and then passed on into the bottling department—a room 100ft. by 25ft. Here the jam is ladled into pots, which are duly covered and put away for market. Around the room were stored innumerable bottles of jam of all kinds. Those engaged in preserving know the extreme difficulty of keeping the fruit whole, but Mr. Beach appears to have no difficulty in this matter, for he showed me a large bottle of strawberries, everyone of which was perfectly whole—this being a special feature in their manufacture. We next came to the store-room, around which it is intended to lay hot-air pipes for the better preservation of the jam. Beyond this room are three other rooms used for packing, &c. Turning through the one to the right, we emerged into the receiving and sorting-shed—a large building about 100ft. square. Here the fruit is brought in from the plantations, between 30 and 40 children being employed to strip the stalks, &c., from the currants and 'snuff' the gooseberries. In this room over 100 gross of glass bottles were stored. Since June 16,000 have been used: they are especially prepared for this firm, consisting of toughened glass, so as to be impervious to heat. At the farther end there were rows upon rows of stone jars containing fruit in pulp. It is intended, however, to shortly convert an adjoining building into a pulp storing room. At the farther end of the factory, near the boiler, is another store-room stocked with jam. The building facing the factory has been converted into a women's mess-room, men's mess-room, and cloak-room; and at the entrance near the road are the offices used by Mr. Smith, who superintends the delivery of the fruits from the plantations into the factory.\*

Mr. Smith, in company with Mr. White, the bee expert, next conducted me to the fruit plantations. They are about two miles in extent, lying in a valley surrounded by hills backed by the Malvern range, about twenty 20 miles off. This plantation originally was an ordinary arable farm, which nobody would take, consisting of over 300 acres and rented at 12. an acre. The soil for the most part is clay. This in Mr. Smith's opinion is preferable for strawberries in a dry season. I was informed that 193 plum-trees go to an acre and 1740 bush trees to the same space and that 75 tons of all kinds of fruit have been gathered this year. In different parts of the plantation are large sheds, the centre of which is for running the fruit into in wet weather after picking. On one side is a coffee tavern (no beer or cider being allowed), and on the reverse side is the sleeping department for the pickers fitted up as a cabin on board ship with twenty-one berths.

In a conversation I had with Lord Sudley he informed me that he was perfectly satisfied with the results of the fruit-plantations; of course, at present he was unable to say whether the tree-fruit would yield very large returns, as they would not come into full bearing for some years; but bush-fruit had entirely come up to his expectations,

\* For many details of the jam-factory I am indebted to extracts from the *Pall Mall Gazette* and *Evesham Journal and Four Shires Advertiser*.

and he could confidently recommend their culture; the present had not been such a good season as might have been expected, owing to the late frosts in the early part of the season.

Walking through one of the largest plantations we next came to the apiary, and I was very pleased to have the opportunity of inspecting a bee-farm worked entirely for profit, and to hear what Mr. White, the combous expert, had to say on the subject. Lord Sudley had previously told me, 'That he considered it was a step in the right direction, and, although only in existence a comparatively short time, it had entirely paid its way.' The apiary originally had been started in order that they might ensure sufficient insects to convey the pollen in the spring to the various blooms; this had perfectly succeeded; and then his lordship turned his attention, not only to this matter, but to make the bees return a fair income on their own account. At present there are 170 hives arranged in two rows. They are, with a very few exceptions, of the same pattern; half-frame hives with flat roofs, sloping backwards, painted stone colour. The frames are the standard of the British Beekeepers' Association, without any shoulders; they are worked cross-ways to the entrance. When I saw them the stocks had been prepared for winter; the frames had been reduced to the number the bees could cover, a chief dummy had been inserted between the first frame and the entrance, the back of the hive filled with chaff; and a chaff quilt, two inches thick, placed on the top. Mr. White intends to work the first cross between the English and Ligurian bees, as he considers hybrids better workers and honey gatherers, and more able to protect themselves against robbers. The apiary was started last April with about seventy stocks, mostly in sleep; which, by transferring and making artificial swarms, have brought the number up to their present strength. Mr. White had many difficulties to contend with; he, besides increasing the colonies, he was able to collect a good harvest of honey, both in comb and extracted. He had experienced many cases of robbing, but always succeeded in stopping it, by inserting into the entrance of the hive attacked a tube of perforated zinc, the equator of each in diameter and six inches long; and if the live from which the assailants came was turned around, allowing the entrance a different direction, it effectually belated the robbers. With regard to feeding, Mr. White liked the bottle arrangement for spring, but found it perfectly useless when building up stocks or for autumn feeding; and had adopted a deep tin feeder, somewhat on the float principle, without that appendage. There had been one case of *Bacillus alvei*, which was entirely cured by feeding with medicated syrup as recommended by Mr. Cheshire in his instructive paper at the Healthies. In the midst of the apiary was the beehouse, a brick building in which were stored hundreds of frames with combs ready for next spring; an extractor which had done much service; it was of the Cowan type, but constructed much stronger than any I had seen, and was fit for considerable work. Here were also immovable section crates, bottles, and all appliances necessary for a scientific apiary; but only such articles as would be of real service and nothing for show. I inquired if they ever had any trouble with bees at the jam-factory, and learnt that the distance, nearly two miles, was enough to keep them away. The bees never take it on kindly to their charge; attempted to attack the fruit. With such bee farms as this and many others that are now being started in England, it will not be necessary to travel to America to learn how apiculture is conducted on a large scale; we are not afraid of our cousins across the water, and we shall not object to their sending us over the produce of their bee-ranches; but we do object to glucose, under the name of 'Table Honey,' 'Honey Dew,' or other such disgusting compounds.

I left Toddington much impressed with what I had seen and learnt; and feel obliged to Lord Sudley for allowing me to carefully inspect the various industries which he is so ably promoting at Toddington.

#### ELECTION OF COMMITTEEMEN FOR 1885.

The time is rapidly approaching when the Secretary of the British Beekeepers' Association will be sending out his annual inquiry to the life members and to the properly qualified subscribers as to whether they are willing to offer themselves for election to the Committee of 1885. Every life member, and each subscriber of 1*l.* per annum, are qualified for this election; but any member who wishes to offer himself as a candidate can do so by raising his subscription to 1*l.*, and announcing his wish to Mr. Huckle. We hope that a goodly list of names will be submitted to the members for this election, and that these latter will choose a body of fifteen gentlemen who will be both willing and able to attend the monthly Committee Meetings, and to give their best attention to the various branches of work which are sure to be before them. No one who can give time and attention to the business of the Association need be diffident in coming forward from a fear that he will have too many competitors. It is by no means easy to find candidates, the only acknowledgment of whose services will be the annual vote of thanks passed at the General Meeting. Nor if a candidate should fail to be included in the first fifteen, need he therefore despair of a place on the Committee, seeing that any vacancy which may occur during the year, according to Rule VIII., will be filled up from the unsuccessful candidates according to the priority of votes obtained at the election. It will be remembered also that at the last General Meeting an addition was made to the number of the Committee by taking in the six unsuccessful candidates who had received the highest number of votes. We cannot say whether such an addition will again be made, but if the work devolving upon the Committee continues to increase as it has done of late years, we think that it will be difficult to furnish all the necessary Sub-Committees from the present number of fifteen, as it would be better if members were not required to serve on more than one Sub-Committee, as all the Sub-Committees may be called together for the same day and hour. The work which up to the present time has fallen mainly upon a few of the members of the Committee should certainly be divided equally between all.

#### ROYAL AGRICULTURAL SOCIETY SHOW AT PRESTON.

We wish to call the attention of our readers to a novelty in the schedule of the bee department at the Show of the Royal Agricultural Society for 1885, which we hope will form a permanent privilege to those County Associations within whose reach a 'Royal Show' is to be held in. The resolution passed runs thus:—'That the affiliated Associations in

Cheshire and Lancashire be allowed to compete at the same rate of entry fees as members of the B.B.K.A.

We are sorry to be informed that no affiliation fee has been received from the Lancashire Association for the last two years, and that unless the Association amends its ways and amalgamates itself with the Parent Association, according to the advice of 'Theta,' the Cheshire Association is the only one likely to benefit by this privilege.

PEEL TESTIMONIAL FUND.

£. s. d.		£. s. d.	
<i>Berkshire.</i>		<i>Kent.</i>	
Acknowledged . . .	2 7 0	Acknowledged . . .	5 1 6
<i>Buckinghamshire.</i>		<i>Lancashire.</i>	
Acknowledged . . .	3 10 6	Acknowledged . . .	2 8 6
P. Brisker . . .	0 1 0	<i>Lincolnshire.</i>	
W. East . . .	0 1 0	Acknowledged . . .	2 17 6
Rev. — Elay . . .	0 5 0	<i>Middlesex.</i>	
<i>Devonshire.</i>		Acknowledged . . .	3 18 0
Acknowledged . . .	0 10 0	<i>Suffolk.</i>	
<i>Cheshire.</i>		Acknowledged . . .	0 10 0
Acknowledged . . .	1 11 0	<i>Northamptonshire.</i>	
<i>Connaught.</i>		Acknowledged . . .	0 5 0
Acknowledged . . .	0 5 0	<i>Oxfordshire.</i>	
<i>Derbyshire.</i>		Acknowledged . . .	0 15 0
H. V. Edwards . . .	0 10 6	<i>Staffordshire.</i>	
Rev. G. Shipton . . .	0 10 0	Acknowledged . . .	1 1 0
Douglas Cooper . . .	0 5 0	<i>Shropshire.</i>	
<i>Derbyshire.</i>		Acknowledged . . .	0 5 0
Acknowledged . . .	0 10 0	C. E. Fletcher . . .	0 10 0
<i>Dorsetshire.</i>		Rev. J. H. Charter . . .	0 5 0
W. H. Duman . . .	0 10 0	R. Palmer . . .	0 5 0
Rev. G. Malbourn . . .	0 2 6	Rev. C. Feilding . . .	0 5 0
W. Meadham . . .	0 1 0	<i>Surrey.</i>	
<i>Essex.</i>		Acknowledged . . .	0 15 6
Acknowledged . . .	1 1 0	<i>Surrey.</i>	
B. K. W. . . .	0 10 0	Acknowledged . . .	0 15 0
<i>Hampshire.</i>		Capt. Campbell . . .	1 0 0
Acknowledged . . .	1 1 0	G. Possett . . .	1 2 0
E. Jackson . . .	0 2 6	<i>Suffolk.</i>	
<i>Hertfordshire.</i>		Acknowledged . . .	1 0 0
T. Wilding . . .	0 2 6	<i>Wiltshire.</i>	
Mrs. Mutlow . . .	0 2 6	Acknowledged . . .	0 2 6
A. Watkins . . .	0 5 0	<i>Wiltshire.</i>	
<i>Hertfordshire.</i>		Acknowledged . . .	4 11 6
Acknowledged . . .	1 0 0		
H. C. Finch . . .	0 10 0		
<i>Wiltshire.</i>			
Acknowledged . . .	0 12 6		

The above list includes the amounts *£1, 16, 6*., received by Mr. J. P. Jackson, and also those received through the County Associations. Mr. Jackson writes that the expense connected with the establishment of the fund was heavy, and that a small balance only of the above amount would remain in his hands after payment of the accounts.

Notice has been given to the County Secretaries of a meeting to be held on Wednesday, December 17th, to consider what steps shall be taken towards the further collection of funds, and to fix a time for closing the account.

CHESHIRE FUND.

Amount to last issue . . . . .	£27 1 6
J. P. Jackson . . . . .	1 1 0
Rev. A. E. Fowler Hill . . . . .	0 5 0
R. J. Tomlin . . . . .	0 5 0
F. H. Lemare . . . . .	0 5 0
L. Wren . . . . .	0 5 0
F. Row . . . . .	0 5 0
H. Forde . . . . .	0 5 0
J. A. Gierin . . . . .	0 2 6
R. Coulton . . . . .	0 2 6
	<u>£29 17 6</u>

THE BRITISH HONEY COMPANY.

A meeting of the promoters of this Company was held on Friday, the 28th ult., to take steps for the registration of the Company, &c. Owing to the last day of the month falling on Sunday we had proceeded to press prior to the meeting being held, and are therefore unable to give a report of the proceedings. We are informed that the promoters recently received an offer to provide the 5000*l.* proposed to be called up on the understanding that the financier should be allowed to take all risk of profit or loss for two years. The offer has been declined, it being the wish of the promoters that the Company should be a co-operative business amongst bee-keepers. We heartily congratulate the promoters on the position their prospect occupies in the commercial world.

IMPORTANT TO MANUFACTURERS AND EXHIBITORS.

Upon reference to the report of the proceedings at the last Committee Meeting of the B.B.K.A. on page 112, it will be found that in the classes for comb honey in sections, one size section only will be admissible in each class.

HERTFORDSHIRE BEE-KEEPERS' ASSOCIATION.

Some Bee keepers' Associations remind us of those minute portions of our solar system which are called 'asteroids.' Some keen-eyed astronomer descries one of these bodies, ascertains its size and its position in space, and gives it a name. But one day it is missing, it has apparently vanished from its orbit. It may be caught up again, but sometimes, under the idea that a new discovery has been made, it passes under another name. Some Associations have been organized, affiliated, and have done a good work in the cause; but from some change in the secretary, or other such reason, it is lost, and the watchman, mounting the highest citadel, in vain scans the horizon, but without any good result. The hope is that it is not lost, and that some one may at length find the missing one and restore it to its former position. Other Associations are weak, and require stimulating, and a firm hand and a mighty arm are necessary to extricate them from the shallows into which they have unwittingly stumbled. But it requires no 'optic tube' to discern a robust and sturdy Association like the Herts. Its organization is a model; its divisions and its subdivisions prove the strength of its constitution. There are no symptoms of ricketiness or decrepitude observable in it. We commend to our readers—and especially our young readers—the report of its recent meeting held at the Town Hall, Hertford. We may say that if it was a profitable and an interesting meeting to those present those who are outside may also derive much instruction from the discussion. The subjects mooted embrace a variety of topics, and there is a boldness and a straightforwardness in the method in which these Hertfordshire bee-keepers treat certain debate-

able points. We feel that bee-keeping in their hands is safe, and we shall be pleased if their example would kindle a like enthusiasm in the other affiliated Associations.

#### CORNWALL BEE-KEEPERS' ASSOCIATION.

This Association is making a strenuous effort to clear off a debt which is a great discouragement to the members, and which is an obstacle to its onward progress. For two seasons the Committee hired a tent for the purpose of giving practical lessons in bee-keeping, and to avoid the recurrence of this expense this year, the Committee decided to purchase a properly constructed beehive tent. This cost 25*l.*, and this expenditure, with serious losses at one or two shows, has left a deficiency upon this year's work of 14*l.* In this are included 15*l.* awarded in prizes at the late show at Truro, which for want of funds are still unpaid. An appeal has been made to the county to assist them at the present crisis. We are pleased that the appeal has been responded to by several of the bee-keepers in Cornwall; and we trust that the debt may be cleared off, so that the Association may be able to extend its influence into every part of the county. Should any friends of Cornwall desire to give their bee-keeping brethren there a helping hand to help them over this difficulty, they are requested to communicate with the Hon. Sec., Mr. C. Kent, *R., Cornwall Gazette Office, Truro.*

#### RAILWAY SLOPES AND WASTE PLACES.

We notice that the Midland Railway Company have decided to set apart the sum of 100*l.* annually to be distributed in prizes for the encouragement of the cultivation of railway slope and waste places of ground at and in the vicinity of the various stations in their line. This is a step in the right direction and one which cannot fail to be agreeable to the travelling public. We trust that our country masters, planters, &c., who are fond of a rural life, will be able to take advantage of this offer.

#### LOAN EXHIBITION OF WOMEN'S INDUSTRIES.

A loan exhibition of women's industries will be opened in Bristol on the 26th of February, 1885. The promoters are desirous that its principal features should be specimens of such work as illustrate the progress made by women in industries demanding special technical and artistic training. It is hoped that articles may be exhibited representing what are termed the Minor Food Industries, e.g., bee-keeping, gardening, dairy work, &c. Inquiries should be addressed to the Hon. Sec., Exhibition of Women's Industries, 20 Park Street, Bristol.

#### USEFUL HINTS.

The weather during November has been on the whole favourable to bees, the temperature being low enough to keep them quiet while numerous fine

days have given opportunities for cleansing flights. As regards the bees themselves there is nothing to be suggested except that they should be left alone. No disturbance of the hives must be allowed on any account.

Roofs must be looked to if any cracks should be found after heavy rain.

Snow, if we should have any, must be cleared away from the entrances, and in hives in which the frames are on loan to the entrances shading must be put to them, to prevent the reflected light from the snow shining in and tempting the bees out to their destruction.

REMOVING WAX.—Now is a good time for this operation. After boiling the old combs and obtaining the wax it will be found more or less impure from pollen, &c., being entangled with it. If boiled with water acidulated with sulphuric acid the impurities will settle more readily than with plain water; but a caution is necessary, when acid is used the vessel must be of glass or earthenware as acid acts upon all the common metals. After settling, the wax must be washed by running and boiling with plain water to remove any trace of acid. As the gravity of the brass is only slightly greater than that of wax, unless the latter is kept hot for some time the former has not time to thoroughly settle out. Therefore the settling vessel should be deep and well wrapped up to keep the wax as long as possible. Properly prepared wax should, when a little is taken away, be tested and held up to the light, to quite a considerable height. If muddy looking it must be washed and allowed to settle again.

WINTERING.—After the people in December, the bees are not so busy as next year's harvest may be. It is a good time to look over the bees, they are hardly gone from the hive, the dirt may advance but may be cleaned out and is likely to be a quiet time to especially examine sections which have to be obtained from America. The question suggests itself, what to do with them? No doubt a larger harvest section on 1 lb. sections than 2 lb. sections than 1 lb. sections, but owing to the important considerations of turning the harvest to the best use, and it will be generally found that 1 lb. sections are far more readily sold than others. This year has a very large winter section market price of 1 lb. sections to 1*l.* each, and the public is that to cultivate. Therefore those who desire a ready outlet for their hives would do well to use 1 lb. Another point not to be lost sight of is the better condition in which they can be sent about the country. Two-pound sections from their weight are liable to break out with a jar which would not damage the one-pound. As to the shape, it will be seen by reference to our report of the last meeting of the B. B. K. A. that the sub-committee recommended that in the classes for 1 and 2 lb. sections of comb honey, the size of the sections should be defined, viz., for 2 lb. sections  $6\frac{1}{2} \times 5\frac{1}{2} \times 2$ , and for 1 lb. sections,  $4\frac{1}{2} \times 4\frac{1}{2} \times 2$ .

INSURGENCE OF CORONAS.—Now that the nights are long and amusements are in country places few, is the time to sow the seed of desire for knowledge

of the improved methods of bee-keeping by any means which local circumstances will indicate far better than any one ignorant of those circumstances can suggest. One way would be to instruct the village carpenter how best to construct cheap hives suitable to the locality. The cost of carriage added to that of the hives made in the towns and the difficulty of sending hives about absolutely ready for use as received being drawbacks to the use of improved hives as opposed to skeps, which can be bought in every village ready for use. To illustrate our meaning: we met this autumn with a skopist who had bought a bar-frame hive. It had been sent with the sheets of foundation to furnish the frames placed between the two division boards tied together. No doubt the seller gave the buyer credit for knowing what to do with them, but a swarm had been put into the empty frames and the two dummies with the foundation between them laid on the top of them. Of course such ignorance is very sad, but a local man would have put all in order when delivering. Whenever steps are taken to interest cottagers by all means invite the carpenter.

## ASSOCIATIONS.

### BRITISH BEE-KEEPERS' ASSOCIATION.

Committee Meeting held at 105 Jermyn Street, on Wednesday, November 19th. Present: T. W. Cowan (in the Chair), Rev. E. Bateman, the Hon. and Rev. H. Blyth, the Rev. H. R. Pool, the Rev. F. G. Jenyns, the Rev. F. S. Selater, Capt. Bush, R.N., Capt. Campbell, J. M. Hooker, H. Jones, D. Stewart, W. O. B. Glennie (treasurer), and the secretary.

The minutes of the last Committee Meeting were read, confirmed, and signed. The Finance Committee presented their Report, recommending the payment of bills amounting to 40*l.* 8*s.* 6*d.*

The Exhibitors' Sub-Committee reported in reference to the Bee Department at the International Health Exhibition:—

(1) That they had forwarded previous to the close of the Exhibition, a communication to the Jury Commission expressing their regret that the interesting and valuable exhibit of Messrs. Abbott Brothers had not been included in the Award List, and requesting that this Exhibit might receive further consideration.

(2) That the Exhibitors had been paid the amounts due to them, and that a full detailed statement regarding the Exhibition was in course of preparation. The Sub-Committee also presented an amended Prize List for the Bee Department of the Royal Agricultural Show, to be held at Preston next year, recommending:—

(1) That in the classes for 1 and 2 lb. sections of comb honey, the size of the sections should be defined, viz., for 2 lb. sections,  $6\frac{1}{2} \times 5\frac{1}{2} \times 2$ , and for 1 lb. sections,  $4\frac{1}{2} \times 4\frac{1}{2} \times 2$ .

(2) That the Affiliated Associations in Cheshire and Lancashire be allowed to compete at the same rate of entry fees as members of the B.B.K.A.

(3) That in the event of the Exhibitors in the Honey Classes not being able to send their Exhibits, the fees should be returned, providing that fourteen days' notice was given of their inability to send the Exhibits.

The report, after some discussion, was adopted. In reply to questions the secretary stated that no affiliation fee had been received from the Lancashire Association for the past two years.

The Chairman moved, 'That application be made to the Postal Authorities to allow samples of honey in glass tubes to be sent by post when packed securely in small wooden blocks,' specimens of which were exhibited to the Committee. Resolved, 'That the Chairman, Mr. Hooker, and Mr. Stewart, be appointed as a deputation to wait upon the Postal Authorities, and to report their proceedings at a future meeting.'

The secretary was instructed to prepare a form for the purpose of collecting statistics relating to the number of hives kept, and the amount of honey produced, through the medium of the County Associations, and to communicate with each county secretary in regard to such forms being published in their Annual Reports.

### HERTS BEE-KEEPERS' ASSOCIATION.

This well-organized association has made what we believe to be another step in advance in the great onward march of progress. The county is divided into twenty-six districts, each having its own district secretary. Mr. R. T. Andrews, the indefatigable secretary of the Hertford district, called the bee-keepers of his district together on Thursday, the 20th ult., in the public hall of that town, at 7.30 P.M. to a 'Conference to discuss subjects of interest, and compare notes on the past season.' Although the night was a stormy one, a fairly good number responded, by whom the two hours were profitably spent, several present not being members of the Association.

Amongst those present were—The Rev. J. Lingen Seager, Hon. Sec.; Mr. J. Huckle, Asst. Sec., Herts B.K.A. and Sec. B.B.K.A.; Mr. J. P. Sambels, one of the representatives of the Herts B.K.A. at the British B.K.A.'s quarterly meetings; Major Croft, Captain Huckle, Messrs. Blow, Buller, Ellis, Robinson, Tuck, Jackson, Winn, Seales, Mallia, McMullen, &c., &c., &c. The Rev. J. Lingen Seager being called to the chair, invited all present to a free exchange of opinion on bee-matters, reserving his own remarks till later on.

Mr. R. T. Andrews, Dist. Sec., said there were from 80 to 90 members in his district, who owned 250 hives, 9 of which were stocked with Ligurian, 6 hybrid, 1 Carniolian, 1 Syrian, and the remainder, as far as he could ascertain, with native bees, foreign bees not being popular in his district. The season had been a very good one. There had been four lectures given during the year, one by the Hon. Sec. at Hertford, and also one at Bayford, Tewin, and Hertford, by Mr. Sambels. He had visited nearly all the bee-keepers in his district, whether members of the Association or not, with a result of gaining twenty-five new members.

Major Croft spoke very favourably of the present condition of bee-culture in the district.

Mr. Sambels corroborated, remarking the sulphur-pit was almost obsolete, and he believed the late plentiful harvest was more the result of the bees being kept in better condition, ready for the glut when it came, than to an exceptionally large honey flow. Skeps, generally in August, were crammed with stores, and breeding was crowded out; but, later on, breeding was resumed, as cells were emptied to permit of it. Cottages generally were not adopting bee-keeping, except the better class; but the bee tent at the parochial flower shows now so general was permeating the county with a knowledge of bee-culture.

Mr. Blow said he had purchased 110 stocks in straw skeps this autumn; they were invariably heavy, with few bees, but queens had renewed breeding in September. He also strongly condemned stimulating queens to late breeding, as very late autumn-bred bees were actually prejudicial to the hive, and the treatment invariably affected the queen the following spring.

The Chairman also strongly condemned this practice, and said last spring his hives contained very few bees,

but he selected his best queen, and stimulated her to laying, giving the combs, as fast as filled with eggs, to his other hives. In this way he frequently got four and five combs of eggs per week, and consequently his nine-stocks quickly got strong, and gave him 500 lbs. of surplus honey.

Major Croft commended this plan, and inquired Messrs. Andrews' experiences of artificial warmth.

The Chairman and Messrs. Andrews, Buller, Jackson, and Blow condemned the practice, giving disastrous examples from their experience. Mr. Blow further adding he had great faith in winter packing. In his own apiary he had a large number of stocks in skeps, but to a casual observer they all seemed bar-frame hives, he having placed the skeps in boxes fitted with tunnelled entrances, the intervening space being filled with chaff. He also remarked on the disastrous consequences of grass and weeds being allowed to grow around the hives, as large numbers of pollen-laden bees in early spring dropped into their midst, to find an untimely death at their own doors.

Mr. Sambels said he was pleased to find late brooding had received its 'death-blow' at the late quarterly meeting of the B.B.K.A., and hoped spreading brood, as recommended and practised, would soon follow suit. This met with a hearty burst of approval from all advanced bee-keepers present.

The question of used combs &c. foundation was next discussed. The Chairman recommending foundation; Mr. Andrews, combs; Mr. Madia coincided with Mr. Andrews. Eventually it was agreed, that in spring foundation was most rapidly filled with brood, but condemned bees should be supplied with combs, filled, if possible, in late autumn, as they invariably gave no profit the following year if compelled to build and fill combs very late in the year.

Mr. Huckle next spoke of the difficulties in the past of finding a market for the disposal of produce, the inability of the B.B.K.A. to establish a market, owing to an adverse vote at the last General Meeting, and the steps that had recently been taken to promote the British Honey Company, remarking on the practice followed by speculators of bottling pieces of home-produced comb-honey, and filling the bottle with corn-syrup or glucose, and palming this adulterated mixture on the public as genuine honey. The British Honey Company would commence its operations in London, and gradually extend its business to every town and village in the United Kingdom. Honey was now being sold by grocers, dairy-men, &c., in London, and their sales were increasing weekly.

Mr. Blow said producers must be content with less profit, as run-honey in bulk could be sold at 6d. per lb. and give good returns, 8d. being a high price. The Chairman said honey at present was a luxury, but he contended this should not be so, as it could be raised at 3d. per lb., and undoubtedly would be so in four or five more years.

This met with strong disapproval from Messrs. Madia, Seales, Ashwood, Bird, and others; but all admitted that cent per cent and upwards was frequently the present rate of profit.

Mr. Sambels said the system to follow in future would be to send honey to the Company in bulk, and thus get a quick, but certain, and relatively small return, the Honey Company taking the trouble of packing, bottling, distributing, risk of bad debts, &c.; or for the producer to take great pains in putting sections up air and dust proof, in an attractive form, and finding a customer in his own neighbourhood at a higher price, thus securing the intermediate profit themselves. He had no trouble to dispose of all his honey put up as the section he produced to the meeting as a sample.

A lengthy discussion here followed on the superior medicinal properties of honey to treacle for cows, and the value of honey as food, especially to children, allusion

being made to Mr. Cheshire's paper, 'Honey as Food,' several cases being quoted of the improvement in physique of children that consumed quantities of honey; but Capt. Hurlock remarked his children had recently taken a dislike to honey, although he believed it to be a most valuable food.

The Chairman asked Mr. Sambels to give his advice as to the management of bees at the present time, who promptly replied, 'Let them alone,' he concluded, of course, they were all carefully packed; if not they ought to be. If short of food candy should be given at once on the top of frames, and all carefully packed up; by no means give liquid food of any kind. In early spring stocks short of food required great vigilance, but should be meddled with as little as possible; much could be learnt by studying the temperature of hives.

Mr. Andrews and the Chairman both deprecated frequent opening hives in spring, and gave results of tests of temperatures during the past spring.

Mr. Andrews said he proposed these district conferences should be held quarterly, if members were agreeable, to which all expressed their hearty approval.

Mr. Blow moved, and Mr. Andrews seconded, a vote of thanks to the Chairman, who had driven eleven miles, and had as many to return, that rough night. Mr. Seager in acknowledging said he had laboured to make the Herts B.B.K.A. second to none in the kingdom, and he was pleased to say it was at present in a most vigorous state; in Mr. Andrews the Association had a dist. ser. that was second to none in his willingness to work. Thus a most pleasant and profitable evening was brought to a close.

#### BERKSHIRE BEE-KEEPERS' ASSOCIATION.

On Tuesday, November 11th, a lecture was delivered in Reading in the Long Room, Lodge Hotel, to the members and friends of the Reading Literary and Scientific Society by the President, Rev. V. H. Moyle, Hon. Sec., Berks B.B.K.A. The chair was occupied by the Mayor of Reading, A. Hill, Esq., and on a large table in front of the audience, the room being filled, were placed numerous samples of all the various kind of articles in the manufacture of which Mr. Moyle has procured the use of British honey, and they included very large range indeed, and not only as food, as beverages, medicines for man and beast, toilet articles, sweets, &c., a number of things suitable for man from the crown of his head to the sole of his foot. The latest novelty were excellent British honey beverages, manufactured by Mr. Stone, wholesale and export confectioner, Broad Street, Reading, at Mr. Moyle's suggestion, and shown that night for the first time.

The Mayor, in opening the proceedings, referred to the very general pleasure felt in Reading at Mr. Moyle's efforts being rewarded at the Health Exhibition by the award to him of a silver medal—the only medal given for this new branch of industry in the whole Exhibition.

The lecturer first pointed out the derivation, and referred to the history of honey; then described it, and the different kinds of pure honey chemically, subsequently referring to adulteration of honey, and showed samples of the same, and explained to the audience the 'Sale of Food and Drug Act,' with the view of enlisting their co-operation with the efforts of British bee-keepers to get our own country's genuine products in this sphere of industry preferred to the various foreign and manufactured rubbish vended in this country.

A very interesting discussion followed, and a very strong determination evinced by all the speakers to do their best by precept and example to show up the worthless character of the adulterated matter so often vended as honey under different names.

Mr. Moyle also referred to the question of transit of sectional honey safely, and strongly recommended those

of his audience who were bee-keepers to procure without delay some of Mr. Baldwin's excellent 'safety crates,' which he said were the best he had seen for the purpose.

The recent successful annual show of the Berks Bee-keepers' Association has been instrumental in increasing largely the number of members of this increasingly prosperous and promising county Association.

#### MIDDLESEX BEE-KEEPERS' ASSOCIATION.

A meeting of the Committee was held, by permission of Mr. Neighbour, at No. 149 Regent Street, on Monday 10th November, the Hon. and Rev. Henry Bligh being in the chair. A proof of leaflet proposed to be issued was submitted, and ordered to be printed and circulated. A plan for division of the county into districts was considered, and the appointment of the following District Secretaries was approved:—Thames Valley, Rev. H. Bligh; Pinner, Mr. Leach; Finchley, Mr. Harveyson; Ealing, Mr. Kenworthy. The Hon. Sec. was empowered to find secretaries for the other districts. A proposal to appoint a collector for the London district was discussed at some length, and eventually the offer of Mr. E. Simpson to undertake the duty was accepted. Votes of thanks to the Chairman and to Mr. Neighbour concluded the business.

#### NOTTS BEE-KEEPERS' ASSOCIATION.

For the information of 'North Notts' and others, who, like him, are interested in the subject, I shall be glad if you will publish the following particulars.

The preliminary meeting of which your correspondent speaks was held early in May, and was very well attended, several influential gentlemen, including the Rev. H. R. Peel and Mr. Huckle, were present. The Notts Beekeepers' Association was duly formed and affiliated to the British. A Committee was chosen, and officers elected. The Rev. A. Halley (who had been the prime mover in the affair) was requested to undertake the duties of Hon. Secretary; he only consented to do so on the distinct understanding that he would only be able to retain the position a few weeks, as he was shortly about to leave our neighbourhood. He called the first Committee meeting for the 24th of May, at which only four members were present. Some little business was settled, such as drawing up a list of the objects of the Association, the choosing an expert, &c.; but the principal thing for which the meeting was called, viz. appointing a successor to Mr. Halley, could not be accomplished, as no gentleman present was able to undertake the office. The names of two or three well-known bee-keepers near Nottingham were submitted as those of gentlemen who might possibly be induced to undertake the Hon. Secretaryship. Mr. Halley promised to call on them, and as soon as he had succeeded in obtaining a promise from either of them, to call another meeting to have the matter settled. Now from that time I have never heard from any one on the subject. As to whether a new secretary has ever been appointed, and, if so, who he is, perhaps some of my fellow-members are better informed than myself, but from results, or rather the want of results, I should imagine not. I, and doubtless others, would be pleased to do anything in our power to forward the interests of apiculture in our own districts; but what can we do without a leader?

When seeking subscriptions towards the Association in May, I was frequently met with the remark: 'It is of no use your trying to form an Association in Notts, for if you succeed it will, after a short time, share the fate of its predecessor, which fell through a few years ago, after a very brief existence.' By dint of perseverance, I, however, succeeded in obtaining five new members, their subscriptions, ranging from a guinea to 2s. 6d., I handed

in at our first and only meeting. Now I am sometimes asked by those same people, 'Well, what progress is the Association making?' The only reply I can give (which to me seems most humiliating) is that, as far as I know, as yet nothing at all has been done.—A MEMBER OF THE COMMITTEE.

#### CALEDONIAN APIARIAN SOCIETY.

Minutes of meeting held in Melnes' Temperance Hotel, 12 Hutcheson Street, Glasgow, on Wednesday, 22nd October, 1884. Present: Messrs. Laughland, Johnstone, Cameron, Young, Sword, Wm. Thompson, R. Anderson, J. Anderson, R. McNally, E. McNally, J. D. Hutcheson, and R. J. Bennett. On the motion of Mr. Bennett, Bailie Laughland was called to the chair. The minutes of last meeting were read and approved of. The financial statement was then read, showing that the Edinburgh Show had given a clear gain to the Society of 20l. 4s. 5d. The Secretary said we were greatly indebted to those members who had come so far a distance, at great personal expense, to make our show a success. He alluded more particularly to Messrs. Tait, Young, Steele, Cameron, McNally, and last, but by no means least, the Secretary of the Irish Association. We had also a visit from Mr. Alfred Neighbour, of London. This gentleman had come often amongst us, and always lent his powerful aid to the good of our Society. This time he brought us some queens that had just arrived from Mr. Frank Benton, and the one he had personally made Mr. Bennett a present of was now the mother of a strong colony. The Secretary read two very interesting letters from Mr. John Wilkie, who has started a bee-farm in Brisbane. Mr. Bennett said we may expect to hear from him from time to time, and he was sure we all wished him success in the land he had chosen. The prizes gained at the Edinburgh Show had all been forwarded to the winners, except the Highland Society's medals, which would be ready in November. The prize schedule for the Aberdeen Show was then revised. Mr. Leslie Tait, of Aberdeen, was added to the Committee. The Secretary stated that as Mr. Tait resided in the vicinity of Aberdeen, his services would be invaluable while there. The following noblemen and gentlemen were proposed to be added to the patron list: The Earl of Stair, Sir John Hay, Sir Herbert Maxwell, the Right Hon. Hugh Dalrymple, and Thomas Dunn, Esq. Mr. Sword proposed a hearty vote of thanks to the Secretary. He said we could not expect to find another gentleman to do so much for us as Mr. Bennett. During the past ten years he had devoted much of his time to the work of the Society, and but for his exertions we must have been defunct long ago. It was another proof of the influence of one man's enthusiasm being able to sway the whole Society along with him, and carry everything to successful issue. A discussion arose as to the best method of disposing of our honey. Mr. Bennett said there was a Company about to be started in London for the sale of honey. Mr. Sword deprecated sending everything to London, as his experience led him to believe that we got as good a price for things at our own doors as there, beside the risk and carriage of transit. A vote of thanks to the chairman brought the meeting to a close.

#### RUTHERGLEN APIARIAN ASSOCIATION.

##### PRESENTATION OF CUPS.

The first annual meeting of this newly formed association was held on Tuesday, Nov. 4, in Rutherglen. Mr. E. McNally, president *pro tem*, occupied the chair. Mr. R. Nish, the secretary, read the annual report describing briefly the steps which were taken to get up the first exhibition in connexion with the Rutherglen Flower Show. The exhibition was a great success, and the committee were pleased to be able to present two cups to



commemorate the occasion. The committee also express gratitude to other friends who spared no efforts to make the first exhibition a success, especially to Thos. Dunn, Esq., of Crossbar; Mr. E. McNally, senior, and Mr. Wm. McNally, Glenties. The donations received had also cleared all the expenses incurred during the year. On the motion of Mr. James Hilton, seconded by Mr. J. D. McNally, the report was adopted. Mr. John Pates proposed that Mr. John Steele now occupy the chair. Mr. Steele, in a few words, called on Mr. R. Nish to hand over the Association cups to Mr. E. McNally, Rutherglen, and Mr. R. McNally, Glenties.

Mr. R. Nish, on rising, said, 'Mr. Chairman and gentlemen, I am sure you all agree with me when I say I have a very pleasant duty to perform to-night, most of you know the gentlemen to whom we are about to show our respect. None of you, I dare say, know so much about their work as I do, but all of you must have had the privilege of hearing through the press about the great success the Messrs. McNally, Glenties, have had with bees and bee-plant, not only in Edinburgh in connexion with the Highland Agricultural Show, but in other parts of England and Scotland. We are all aware of the grand display which our society inaugurated this year through the efforts of Mr. E. McNally, who spared neither time nor means in making the exhibition successful. He has in this matter only carried out what I know personally of him, that is, his unselfish method of doing good to all around him, entirely forgetting his own benefit. Many of you here can say as much from what you know of his past labours in Rutherglen. Again, our exhibition would have had very little attraction this season at least had it not been for the assistance of his brothers from Glenties. Mr. R. McNally's observatory hive was a study of itself, and one thanks to him for this display is now given in the shape of the silver cup before me. Mr. E. McNally has not the opportunities which his brother has for experience and practical work, but by his experiments, writings and addresses, I can safely state that he is one of the first of amateur bee-keepers in Scotland.'

The cups were then presented to Messrs. E. and R. McNally, who feelingly acknowledged the honour conferred upon them.

The cups bore the following inscriptions: 'Awarded Ebenezer McNally for first exhibition of honey bees, &c., 1884.' 'Awarded R. McNally for observatory hive, 1884. Rutherglen Apianian Society.'

Arrangements were afterwards made to get up a complete schedule of prizes for the show next year, and a full committee was elected.

#### IRISH BEE-KEEPERS' ASSOCIATION.

The Annual Honey and Hive Exhibition was held at Fall's Bridge on October the 29th and two subsequent days, and was the most successful ever held under the auspices of the Association. Competitors from England and Scotland were to be found in all the classes, and many firms were personally represented, amongst whom were Messrs. S. J. Baldwin, Bromley, Kent; Edmondson Brothers, 10 Dame Street, Dublin; W. Lonsdale, Lurgan; W. R. Orr, Strabane, &c. The following is the prize list:—

For the best crate of twenty-one 1-lb. sections.—1st, 17, Mr. Laurence McCormick, Swords; 2nd, 10s., Mr. W. T. Bead, Straffan; V. H. C., Mr. F. H. Jones, Mullingar, Waterford; H. C., Mr. D'Oliver, Bray. For the best crate of twelve 2-lb. sections.—1st, 17, Mr. Tom Sells, Uffington, Stamford; 2nd, 10s. Rev. R. Seymour, Armagh; H. C., Mr. D'Oliver, Bray. For the best super of honey—wood, straw, or glass, or combination of any of these—not sectional.—1st, 15s., Rev. Robert Seymour, Armagh; 2nd, 10s., Miss Berta Doxey, Gorey; V. H. C., Mrs. John B. Murphy, Littlefield, Jenkinstown; H. C.,

Mr. W. R. Orr, Strabane. For the best twelve jars, 1 lb. each, of extracted clover or light honey.—1st, 15s., Miss Isabella Lefroy, Cardenton House, Athy; 2nd, 10s., Mr. D'Oliver, Bray; H. C., Mr. Raby, Hawthorn, Blackrock. For the best twelve jars, 1 lb. each, of extracted heather or dark honey.—1st, 15s., Mr. Duffin, Whitechurch House, Cappagh; 2nd, 10s., Mr. D'Oliver, Bray. For the best hive of a substantial character, for general use in an apiary.—1st prize, silver medal, Mr. S. J. Baldwin, Bromley, Kent, and Messrs. Edmondson Bros., 10 Dame Street, Dublin; 1st equal; H. C. Messrs. W. Lonsdale, Lurgan, and W. R. Orr, Strabane. For the best and cheapest hive on a moveable comb principle, for cottagers' use, with arrangements for summer and winter, price not to exceed 10s. 6d.—1st prize, silver medal, Mr. S. J. Baldwin, Bromley, Kent; 2nd, bronze medal, Mr. William Lonsdale, Lurgan; V. H. C. Messrs. Gissen & Sons, Rainham, Kent. For the best straw hive for draining purposes.—1st prize, silver medal, Messrs. Edmondson Bros., 10 Dame Street, Dublin; 2nd, bronze medal, Mr. W. P. Meadows, Syston, Leicestershire; V. H. C., Mr. W. Lonsdale, Lurgan; H. C. Messrs. W. R. Orr, Strabane, and Tom Sells, Uffington, Stamford. For the best honey extractor for two combs at a time.—Prize, silver medal; 1st, Mr. William Lonsdale, Lurgan; V. H. C. Messrs. Edmondson Bros., Dame Street, Dublin. For the cheapest extractor.—Prize, bronze medal; 1st, Mr. W. P. Meadows, Syston, near Leicestershire. Bee-driving.—1st, 17, James Traynor, Timahilly; 2nd, 10s., W. Lonsdale, Lurgan. Comestibles were exhibited at the Show, and attracted a large amount of attention. The Show was, for the first time, open for three hours in the evening, and the experiment was fairly successful. The Committee at their last meeting recommended a number of additions to the prize list, including one for lady exhibitors, medals for wax, observatory hives, &c., &c.

#### THE NORTH-EAST OF IRELAND BEEKEEPERS' ASSOCIATION.

The members of the above Association met at 11 Watling Street, Belfast, on Friday evening, 7th ult., for the purpose of hearing the Rev. H. W. Gott, of Lurgan, read an essay on 'The Honey Bee.' During the course of his remarks, Mr. Gott said that he had had a good deal of experience of the want of knowledge about our common honey bee existing amongst all ranks and classes in our district, and that he made no apology for the simple facts and remarks in his essay, all of which were as well known to some of his hearers as to himself. His endeavor was to help those who were beginning to be bee-keepers, and thus to carry out the intention of the North-East of Ireland B. K. A. in providing the series of papers of which this was the first. He referred to the nature of the bee, which is the same as that of any perfect insect—first the egg, then the maggot, which on the ninth day becomes a nymph like the chrysalis of the butterfly, and which finally on the twenty-first day, becomes the busy bee that gathers honey all the day from every opening flower.' He then proceeded to describe in a very interesting manner the different inhabitants of the hive, viz., the queen, the drones or males, and the workers, and dwelt on the patient observation of the great Huber and his faithful companion, to whom, although blind, we owe most of the information which we possess about the honey bee. The essayist then spoke of the different homes of the bees, from the carcass of the lion which Samson slew to the church-roof, or the chimney crooks of Cashmere; and of their products, honey, pollen, or bee-bread, wax and propolis, all of which they gather from flowers or trees except the wax, which is secreted. Mr. Gott proceeded to relate what is known of bee-keeping in Ireland, going back as far as the sixth century, telling of a certain St. Dominick who

after being taught by St. David in Wales, returned to Ireland, bringing with him swarms of bees, which, it has been strangely said, were the first seen in Ireland. After some remarks by different members present, the meeting was brought to a close by a cordial vote of thanks to the lecturer.

On Dec. 5 a lecture will be delivered by Mr. Wm. Ditty of Newtownards on 'The General Management of an Apiary,' and on Jan. 9, 1885, Mr. Paul Henry will give 'A Bee-keeper's Experiences.' The Hon. Sec. of the Society is taking steps to ascertain the amount of honey collected during the past season. We append the form which he has forwarded to the bee-keepers of his district:—

Kind of Bee.	Straw Skeps.	Bar Frame Hives.	Honey.
Common .. ..			Lbs.
Ligurian .. ..			Lbs.
Hybrids .. ..			Lbs.

## Correspondence.

\*\*\* All Correspondents forwarding Letters for insertion in the Journal, Reports of Associations, Shows, Meetings, Echoes from the Hives, Queries, &c., are requested to direct their communications to 'The Editor of the "British Bee Journal," c/o Messrs. Strangeways & Sons, Tower Street, Upper St. Martin's Lane, W.C.'

### OUR HONEY IMPORTS.

The value of honey imported into the United Kingdom during the month of October, 1884, amounted to 5888l. [From a private return sent by the Principal, Statistical Office, H.M. Customs, to E. H. Bellairs, Wingfield, Christchurch.]

### DIRECT QUEEN INTRODUCTION.

I trust the Rev. George Raynor will now admit that there is more in my system than he has yet been able to discover, seeing that his own statements, so far from containing the truth as he wished it to be believed, have elicited the testimony of so large a majority in favour of the process.

Now, if so many have succeeded, including myself and numerous others who, unsolicited, have written privately, saying how they have succeeded many times in succession, why has Mr. Raynor so signally failed? If he has faithfully followed my process, then of course he is justified in saying what he has; but on the face of it, he certainly has not followed me, or he would succeed as I and others have done.

In the first place, contrary to the general rules of manipulation, he omitted to use smoke, and next (p. 342, vol. xii. of this *Journal*), after quoting two Americans who had failed in their first attempt, he says, 'I also have experimented in the same direction with Italians, Syrians, Cyprians, and blacks, and in *no single case* has the queen been received. In some encasement has immediately followed the introduction, and the poor queen has been rescued; in others she has been mercilessly slaughtered.' Mr. Raynor but too plainly tells us where he has failed, when he says that the queens were *immediately* balled or otherwise slaughtered. I always close the hive 'at once,' and do not again disturb the colony, as, in all probability, by 'fussing' to see if the bees agreed, I should bring about that state of things it is desirable to avoid. On referring to p. 100, vol. x., of the *B. B. J.*, where I first mentioned my success, we find the following sentence:—'As soon as the comb,

queen, and bees are inserted, the job is done, and I never trouble to look at the hive again until its turn comes in the ordinary course of manipulations.' But when a bee-keeper, at the last moment, becomes incredulous, and must needs open the hive immediately, or more likely than not keep the hive open until he sees what becomes of the queen, then I say, he is not following my plan, but one of his own, and by so doing is simply courting disaster.

How absurd! Are not many of our manipulations with the modern frame-hive 'diametrically opposed to the natural instincts of the honey bee?' Why then should such a plea be put forth against this one process in particular? Nevertheless, if any one process of introduction is more nearly natural than another, all reasonable men will admit that it is this, which permits of a queen being given to a colony without being handled, while she remains among her own attendants, and frequently is so little disturbed that she is laying while the operation is being performed, and continues to do so from the first moment she is inserted in the new colony.

Mr. Raynor, speaking of our former correspondence, says, 'Since that time Mr. Simms has fully described, in the *American Bee Journal* of July 16th, 1884, p. 456, his system of introduction.' Here he is quite mistaken. I have on no occasion whatever forwarded an article on this subject to the *A. B. J.*, and had Mr. Raynor noticed the absence of the customary head-line 'For the *American Bee Journal*,' he would have known that the same was simply an extract inserted by the editor upon his own responsibility. Probably it was taken from my pamphlet of which I had forwarded him a copy some eighteen months previously, and which was duly acknowledged at the time.

In his last letter Mr. Raynor makes an admission, which is equivalent to saying that, after all, the process as carried out by myself is a success, when he says that the two Americans must have failed because they used no smoke. Probably since my first letter correcting the misunderstanding upon that subject, Mr. Raynor has tried again, as under ordinary manipulation. If not, why does he continue to condemn what he has never tried? If otherwise, *why then has he failed with smoke?* Perhaps a reference to foregoing statements regarding the final precaution will show why.

In Mr. Raynor's letter of Nov. 1, he says, 'It has always been considered an axiom in bee-culture that "bees, when in a normal condition will defend their hives against all enemies, even against attacks of their own species." Now, though he considers this the vital point, and sufficient to condemn my system, yet I assure him that I quite agree with him as to the correctness of that quotation. But, reader, note this: 'against all enemies' even against *attacks* of their own species; now we see how the whole fabric of his criticism falls to the ground, for, in truth, by the means I adopt, and recommend, the queen with her bees are inserted in such a manner that they are not regarded as enemies; they do not attack, neither are they disposed to attack, the bees they are introduced to; all being at home, and under the same quiet treatment.

Mr. Raynor continues: 'When, in your columns some time ago, I objected to his method, that this direct introduction was accomplished without the use of smoke—the word *never* once occurred in his pamphlet—his reply was that he did not wish it to be understood that he dispensed with smoke. But, as far as I am aware, he has not yet recommended its use.' Why will Mr. Raynor persist in such useless statements? So far from him calling my attention to the matter, he did not refer to direct introduction in these columns until *after* my letter on p. 84, vol. xii., wherein I distinctly said that 'I *always* use smoke, and (except during a honey glut) should consider it the height of folly to

neglect that important item; and further: 'It is so generally understood that smoke is necessary during manipulation, that I deemed it superfluous to give instructions on that point' [in my pamphlet]. The said statements were inserted because I had found several bee-keepers were under the impression that smoke could be dispensed with while introducing queens. Surely Mr. Raynor cannot have forgotten the letter of that date, which started all his criticisms that have appeared in this *Journal* on the subject.

Mr. Raynor is mistaken in supposing that the 'greatest' confusion follows the application of smoke (as usually given), and that the bees no longer defend themselves. A temporary and partial confusion, of course, does occur, but the 'greatest' confusion is attained only under the influence of excessive smoking, and when the bees are being driven, or its equivalent—shaken from the combs. Under the influence of smoke as used in ordinary manipulation, let a robber bee hover around, and it is at once attacked, and even an earwig, should it venture into the hive under treatment, is immediately stung and carried out (so much for the knowledge of the merest tyro); and yet all the time the manipulator is untouched, because of his careful and systematic action. And, under the same conditions, with the same care on his part, he can insert a portion of another beehive, with its queen, and no accident occurs.

The plan of running queens in at the entrance with a deluge of smoke I have not recommended, because I know it can seldom be depended upon, which Mr. Raynor admits, while apparently contradicting himself. Thus we read his statement: 'I, with many others, have repeatedly and successfully smoked in queens at the entrance of the hive without any cuzzing at all.' . . . Nevertheless, it is not a method which I would recommend to a novice. Often after the effect of the smoke has passed away the queen will be smothered, hence great vigilance is required when practising it.' By all means let us use a cage rather than trust to such an arrangement which necessitates immediate inspection, and often the continued application of volumes of smoke, until the whole economy of the hive is thoroughly disarranged, to say nothing of such waste of time. 'What progress!'

Mr. Raynor considers it an easy matter to introduce queens direct to those nuclei or other colonies that have none but young bees. Of course; but then it is a simple fact, continually occurring in my apiary, that queens are directly inserted into any and all colonies alike, whatever be their condition, whether full colonies, if with fertile workers, broodless bees, or those having queen-cells in any stage of existence, notwithstanding a recent editorial reply, stating that bees will never take to a new queen while they have queen-cells.

As a last resort, Mr. Raynor vainly endeavours to withdraw from a false position, by laying much stress upon the fact that those correspondents who have recently given favourable reports, must have used colonies in an abnormal condition. Here, again, he unwittingly acknowledges the correctness of my practice. Of course, the colonies operated upon were in an abnormal state. Whoever thinks of giving an alien queen to a colony, by any known process whatever, unless he first destroys its normal condition by removing the original mother; and again, the simple act of bringing a colony under manipulation causes it, for the time being, to be in an abnormal condition, whether smoke be used during the operation, or not.

While apologising for taking up so much of your valuable space, in replying to Mr. Raynor's last three letters, I cannot conclude, without first thanking those gentlemen who, both publicly and privately, have given their testimony in favour of my system. — S. SIMMONS.

## DIRECT INTRODUCTION.

I have been a constant and regular reader of your *Journal*, subscribing for the same with Mr. A. I. Root, of Ohio, U.S.A., editor of *Gleanings*. I am much pleased, and also instructed with and by the articles and editorials I find in your columns. Among the many good things I have found there, was the 'Simmons' Method of Direct Introduction.' When I first read it, I said at once 'Eureka.' Of course I gave the method a trial, but with fear and trembling I admit, it being so much at variance with preconceived ideas, and the ordinary rules in regard to the matter.

It proved a success with me, however, in the first instance, and out of several introductions made in the way advised by Mr. S., I have met with but one failure.

Others this side the water complain of failures in using the method; some of them being successful bee-keepers. It may be, however, that they made the attempt with no desire to succeed. However that may be, I have succeeded with it beyond my expectations, and for the life of me, I can't see why any one should make a failure of it.

I have a method of introduction, however, which I far prefer, and one that I believe will be a success at the hands of any one, novice or expert, and its extreme simplicity commends it to all. It is as follows: On the forenoon of a fine day, when bees are flying freely and gathering honey freely also, remove the queen from the desired colony. At night of the same day, and after all the bees have come home, give this colony enough smoke to cause the bees to all fill themselves with honey. After five minutes or so, or when by their peculiar 'hum' they show themselves well filled and in a happy mood, allow the new queen to run directly in at the entrance. I have tried this method many times, and as yet no failure. My theory is, that the bees having mis-od their queen, are looking for her to come in at the entrance; and when the new one comes in, she is received naturally, because she comes in in a natural manner, and as the old queen would come had she simply taken a visiting flight. I have satisfied myself that queens do take an occasional flight from the hive, and this fact is a solution of bees that cannot otherwise be accounted for. I have satisfied myself, too, that bees do not have any distinctive scent by which they determine strangers from their own colony, but that the actions of both bees and queens, when by chance they get into a strange hive, prove them enemies, and cost them their lives. I trust your *Journal* will live long and flourish, and meet the encouragement it so richly deserves. JOSEPH E. POXB, Jun., *Farboro, Norfolk Co., State of Massachusetts, U. S. A.*

## DISSECTING BEES FOR EXAMINATION.

I see in 'Notes to Correspondents,' in your last issue, Mr. Cheshire makes a half promise to give us an article on dissecting bees for examination. I am sure many of your readers would welcome such an article at this time of the year, when the long evenings would give them an opportunity to work the suggestions out; and if not trespassing too much on Mr. Cheshire's time a few hints would be acceptable as to what parts would mount well as permanent objects for the microscope; also as to the best means (suitable to the particular object) of preparing for mounting, what solvents should be used, as I imagine some of the more delicate membranes would be entirely spoiled by the use of liquor potassæ, &c.

I, for my part, shall carefully work out as far as I can, the suggestions in Mr. Cheshire's last article on 'Structure of the Egg Organs of the Queen,' and I believe such subjects will do a great deal towards the more intellectual study of 'The Honey Bee.'

Will Mr. White allow me to encourage him in his wish to get a microscope for the purpose, as I am sure

when once he starts he will find the work so exceedingly interesting the evenings will be all too short, and the knowledge gained well worth the trouble and expense. C. BROWN, *Beccles, Nov. 21, 1884.*

#### TITS AND FLYCATCHERS.

I can fully bear out your correspondent, F. H. Hills, in his remarks in the last issue of the *Bee Journal*, regarding the English flycatcher, or beam-bird, having a taste for bees. Last year was the first time I observed this bird destroy them, and knowing that it is stated by different authorities on birds that flies form the principal or sole food of flycatchers, I determined to watch and observe more closely its movements this year, with the result that I have proved it to be no small destroyer of bees. I have three hives of bees in a very quiet and secluded corner of the orchard. A wire fence, about four yards in front of the hives, divides the orchard from a meadow. On this fence the flycatchers take their station, and dart upon the bees as they are passing to and from the hives, and destroy them by scores. I have seen them even swoop down and take the bees from off the daisy flowers. I have watched at the hives for half-an-hour to an hour at a time, with watch in hand, and found, on the average, a bee a minute destroyed while the birds were there. So tantalising was it to see the bees destroyed day by day in this fashion that, like your correspondent, I thought a little powder and shot would be the best antidote. Accordingly I fetched my gun, but, by the time I got back to the hives, I had repented of my resolution, for, having rather a weakness for the feathered tribe, a little reflection told me that a bee on the wing is quite as much object a prey of the flycatcher as a fly or any other insect. I tried other means to frighten them from the spot.

While watching the flycatcher, brought to light the fact that another bird, the 'red-start,' does not despise a bee occasionally for food for its young ones. I observed a pair of these birds very busy at times catching the bees and taking them to their young ones in a nest in the garden wall close by. They did this for about a fortnight, till the young ones had flown. I did not observe them to catch any more after this.

I never saw the flycatcher take the bees away, but always appeared to eat them on the spot, generally alighting on a post-top, and giving them two or three dexterous taps, as though they extracted the sting before swallowing the bee.—A COTTAGE BEE-KEEPER, *Herts.*

Owing to illness in my family I did not find time to read the *Journal* of the 1st inst., and it was not until I read Mr. Hiam's letter in your last issue that I found there was an error in the wording of my letter. It should have been the above birds (meaning the tits, not the flycatchers) remain with us the whole year; the latter generally arriving about the 12th of May, and leaving us the latter end of September. In 1880 they did not reach us until the 18th of May. I cannot give any experience of the pied flycatchers, as they do not visit this immediate neighbourhood.

In my last paper I promised to write to several ornithological friends on the subject and give their report. I have written to eleven, but have only received replies from nine. The first says, 'Though I have been a careful observer of the habits of birds all my life, and I am now nearly seventy, I have not, up to the present, seen or even heard of the spotted flycatcher taking either the humble or the honey bees.' No. 2 writes as follows: 'I should think it almost impossible for flycatchers, with their weak beak, to be able to master bees.' No. 3 'never remembers to have heard of the spotted flycatcher eating bees, but would certainly expect him so to do, as it is his nature; but at the same time thinks that the worker bee would be too quick for him, and, therefore,

he would only take the drones.' No. 4 writes that—'Although I have stuffed birds for over thirty years, I have no remembrance of finding any trace of bees when opening either the pied or spotted flycatchers, and I do not think they will take them.' No. 5, a professional birdstuffer, writes to this effect—'That I have made my living by stuffing birds for seventeen years, and during that time have stuffed a large number of the spotted flycatcher, both old and young, and am quite sure they do not take bees, or I should have found traces of them ere this.' No. 6 says—'Though I have been a keen observer of birds for many years I have not, up to the present, seen the flycatcher after bees, and I do not think it troubles after them.' No. 7 writes—'The spotted flycatcher is pretty plentiful in my grounds, and I also keep bees for a hobby, but neither I nor either of my gardeners have the slightest remembrance of seeing them chase bees. I cannot speak of the pied, it not being common with us.' No. 8 writes as follows: 'In reply to yours, as you are already aware, I have made it my hobby all my life to watch the habits of birds, and the flycatcher is a particular favourite of mine, and I am quite surprised at your asking me whether they will take the honey bee. I should have thought you knew better. I feel quite sure that they do not. This year a pair has again built in the ivy on my summer-house. I wish they would kill bees, for if they did probably they would also kill wasps, which would be a great boon, as the wasps this season have been an intolerable nuisance.' The last letter I had contains this extract: 'I certainly never remember seeing a bee taken by a flycatcher, and should exceedingly doubt their being able to eat them. An insect the size of a bee would just about satisfy one of them, and yet they are on the wing catching flies from morning to night, which one would hardly imagine to be the case were they in the habit of eating bees, one of which is enough for a good meal. So far as I have observed a drowsy flycatcher is an unusual sight, very.'

I have purposely kept back the names of the writers of these letters from which I have taken the above extracts, but I may say that several of them are well known to the world, not merely by name, but by their works, which have become a household word to ornithologists; and, as you wish the correspondence on this subject to end with this issue, I will only add that I shall be only too glad to communicate with any one on the subject, and hope your readers will make a careful observation of their habits during the summer of 1885. I should esteem it a great favour if Mr. Hiam would kindly forward me through the post the dates of arrivals and departure of the flycatcher during the past few years.

Trusting I have not trespassed too much on your valuable space, my plea must be that I am such a lover of the feathered tribe, who will always find a friend in—G. J. BULLER, *Welwyn, Herts.*

Till this last spring, for the last seven years, I was Vicar of Westwood, near Coventry, and my home was a lone house under a wood. The garden extended some thirty yards in front of the house, and was bounded by iron hurdles, on the garden side of which was a bed of prickly conifer, much frequented by humble bees, and occasionally by my own black bees. The flycatchers always built in the roses against the house, and the iron hurdles were their favourite feeding perch. Thousands and thousands of times have I seen them rise, flutter in the air, and catch a midge or a gnat, but never once strike at a bee.

For the last three years the blue-tit built in the bottom of my letter-box, laid its ten or eleven eggs, and always hatched and reared them all, though seven or eight better, and sometimes more, tumbled into the box every day. But the little architect raised the sides of its nest

rather high, so that the letters could not touch it, though they came very close; and one would have thought would have prevented the little bird getting in or out, for the box was very small. But no, it suited her family exceedingly well, and Mrs. B.-T. never wished for a better or a quieter home. The family usually spent the winter in and about my garden, but I never saw them take a bee.

The tom-tit I never saw in that parish, which I often thought very singular. Here I have tom-tits and blue-tits in the garden, and shall keep an eye on them this winter.

Before I close this letter, permit me to say a word for two other feathered friends, who I saw as recently as last summer falsely accused in the *Standard* of sometimes snapping up a bee, viz., the chimney swallow and the house martin. My dressing-room at Westwood overlooked a small back yard, on one side of which was a lean-to shed. This was a most favourite home of swallows and martins. I counted last year no less than twenty-three nests, inhabited at the same time under that one shed, besides many other nests in the buildings around the house. The swallows and martins passed in numbers under my dressing-room window, which was on the first-floor, to and fro to their nests all day long; and the young ones sat by the dozen on two or three clothes-lines that were stretched across that yard. In that dressing-room window I placed an observatory hive, but though I watched long and anxiously I never saw a single bee molested.

Westwood was a famous locality for birds. On June 13, 1883, I had the exceeding pleasure, for the second time that year, of watching through a strong pair of opera-glasses a great spotted woodpecker; a hen bird, I believe, as I could not distinguish the red on its head. A friend of mine also saw certainly a pair of the lesser spotted woodpecker in the spring of that same year, but I never had the good fortune to see them myself. J. G. COUSMAKER, *Hunstall Rectory, Knapton, Staffs-shire.*

I have been much surprised at the accusations being put against the spotted flycatcher of being a bee-killer. Many pairs have their nests each year in the crevices of my house, and the old trees about the garden; and I have never once seen them go near my hives or capture a bee. I have never killed one and would be very sorry to do so. These quiet little visitors are great favourites of mine, and I would not permit one of them to be disturbed. My experience of the great tit (*Parus major*)—I am a lover of nature and fond of all animals and plants—is that he and she are most destructive to the bees. I have seen them watching at my hives, of which I have eight, and picking up every bee that appeared. This work of course goes on only in winter; they do not go near the hives so far as I have seen (and I am a bee-keeper of many year's standing) in summer. My advice then is, shoot the tits but spare the flycatchers. H. W. LEFT, M.A., *Ardarae Glebe, Lugan, Ireland.*

The discussion in the *Journal* about Tits and Flycatchers eating bees shows at any rate that a collection of carefully recorded facts is wanted. But has not the importance of individual variations been somewhat overlooked? Individual variations in habit as well as in structure have been shown to exist in almost every living species; and just as in India individual tigers occasionally become man-eaters, though as a rule tigers prefer other prey to men, so may it not be that in England individual birds occasionally become bee-eaters, though the rest of their species usually prefer other prey to bees? Thus, suppose a great tit in winter, when cold and hungry, to be searching an old skep for pupae of the wax-moth, or other dainty morsels, and by his vigorous tapping to fetch a bee to the entrance of the skep, is it unlikely that he would eat the bee? and if he were unable to find other

food, is it not likely that he would fetch out another bee the next day by a similar process?—and this without its being at all the usual habit of great tits to eat bees. To make a wholesale destruction of such useful birds as tits because a few individuals take to eating bees would be very false economy. Let bee-keepers destroy only those particular individuals which they find to be eating their bees, thus not only will the innocent ones be left to destroy the wax-moth and other harmful insects, but the whole species will be improved, for by a constant destruction of the bee-eating individuals, a process of selection will be set up, and the taste for eating bees will in future be less often developed than it is now. When a bird takes to tapping at the hive entrance, a good thing to do is to set an unbaited bird-clam in such a way that the bird will stand on it whilst tapping.

Tits have undoubtedly been seen in winter eating bees at the entrance of my hives. One year I believe one came regularly every morning till it was shot. I narrow the entrance of my skeps with movable blocks of wood, and judging by the frequency with which these are disturbed in winter, I should think that the visits paid them by birds are not uncommon. I have had reason to suspect other birds than great tits, but unfortunately I have as yet been unable to make any accurate observations, still I feel sure that there are many innocent tits in the garden.

Although Mr. Herbert has shown that flycatchers may eat drones, I cannot help thinking that they do not often do so, yet when he says they dare not out a work (so because of its sting), he apparently assumes that they have tried, and been stung.

Might I suggest that any bee-keeper who suspects a bird of eating his bees should watch it carefully, or kill it and examine the contents of its stomach and crop, and if ever a morsel of bees are found, that they and the bird's claws could be preserved, and the fact recorded in the *Journal*. If any one did not like to undertake the dissection, he could find others that would; if not I would myself gladly dissect any bird that was sent me. It seems to me a pity that the Central Association has not a special department for collecting and sifting the numerous observations in natural history which must be made yearly by British bee-keepers. G. D. HAYLAND, *St. Bartholomew's, Bristol.*

#### A YEAR'S REPORT.

I last year sent you a diary of my bee-keeping for the year, showing the produce of two stocks to be 60 lbs. 12 oz., and an additional stock added to my apiary. Although this year seems to have been a good one elsewhere, I cannot say much for it in a bee-keeper's light in this district, namely, as from a 1st July swarm which was put in a skep, I only got 4 lbs. 1 oz. of honey, when I united it to one of my stocks on the 26th August, and from a 4th July swarm, also lived in a skep, I only took 1 lb. 8 oz. when uniting it to another stock on 15th October. I have made inquiries of shopkeepers in my neighbourhood, and they seemed to have fared as badly, in fact, they say it was the worst season they had this long time.

Notwithstanding that my produce this year falls short of last year's by about 4 lbs., although I commenced with one stock more, I must say that the result shows a good deal in favour of bar-framed hives, for, although I got so little from my skeps, I was able to take 3 lbs. 8 oz. of honey, on the 6th of August, from a 23rd of June swarm and leave it, without feeding, with sufficient food for the winter of course it was supplied with comb foundation. My diminished harvest this year I greatly attribute to swarming, as I had two swarms from one stock, and one from another, and the old motto, "United we stand, divided we fall" may well be applied to a stock of bees. If I had time I would have endeavoured to pre-

vent swarming, and if I did not succeed, would then have returned the swarm; but, being mostly away from where my apiary is, except in the evenings, and then not always caring to spend my time in the company of bees, I was unable to do either. I have one stock in a hive 16 $\frac{1}{2}$ "  $\times$  14"  $\times$  11 $\frac{1}{2}$ " which is suited to hold a frame containing four 2 lb. sections at back; and although it has not been thoroughly cleaned since 1882, I found it to be my best this year, producing 26 lbs. of honey, including 5 lbs. which I got from its two swarms, and enabling me to unite one of its swarms to strengthen a stock in the autumn, besides giving me an additional stock well supplied for the winter.

A stock in a standard frame-hive only produced 16 lbs. 9 oz., and a swarm and another only 15 lbs. 13 oz., besides six sections filled with comb between them, which I have stored to give back to be filled next year.

My 2-lb. section hive produced 22 lbs. 12 oz. last year, and the sections were each time better filled than the 1-lb. sections at back of the other hives. I found, however, that by taking all the filled sections out of a frame, the bees did not seem to care to fill new ones. In *bee flora* the *Melilotus alba* has not been much mentioned, although it blossomed with me profusely even when sown in very poor ground, and was covered with bees continually from the time the limes were in blossom up to the second week in September; the only fault I find with it is, that it is a biennial and only blossoms the second year. Quantities of bees were working on ivy and Michaelmas daisies up to near the end of October.—Boz.

#### CURIOUS COUNTRY CUSTOMS.

Some twenty miles on the north side of the Humber is a small country village known as North Frodingham. It is remote from any railway station two leagues, and only on certain days in the week, when the bus runs or the carrier's cart goes to market, is it possible to get to the station without briskly exercising one's understandings. I lately heard of a very curious custom which is prevalent there, and as it afforded me much interest it may also be of interest to others.

An old lady recently came to the end of her earthly pilgrimage who during her lifetime kept bees. Arranged in a line at the back of the house in the garden were four straw skeps containing bees which were intended to be kept during the winter for the next season. Immediately the old lady died, some few weeks since, these bees were put in mourning until after the funeral. A piece of black cloth or ribbon was tied to each hive with becoming reverence and sorrow, and the bees liberally supplied with bread and cheese and ale. Being somewhat struck with this singular incident, I inquired what these things meant, and was informed that if the bees were not put in mourning and supplied with cheese and ale they would die—they would not live through the winter. Now there is no fear of them dying. The bees are supposed to have sorrow upon sorrow on account of the death of their mistress, like her friends and relations, and must, like them, wear signs of mourning. On the day of the funeral, when the last offices were performed, friends and neighbours gathered to manifest their respect, and, as the custom is in these remote places, refresh themselves with wine and provisions that are bountifully provided. The poor, sad bees must come in for a share, so there is taken to them a portion of the good things. In order to ascertain correctly whether these things be so in the nineteenth century I went to the house a day or two after the funeral and made inquiries. Posters were put out for a sale. 'You have some bees to sell, have you not?' 'Yes, we have four hives.' 'But,' I said, 'the winter is coming, and if it be severe, or if the bees have not much honey, they will die.' The words were scarcely uttered before a pleasant-looking house-wife chimed in, 'No, they won't. Oh, no; we put them in mourning and have given them

each some bread and cheese and ale. See, come and look at them, it's on yet.' Saying this she led the way through the back door about twenty yards up the garden, and showed the strip of crape tied to each hive on the end of the sticks that support the comb. I failed to perceive the sorrow of the bees as they merrily sailed away to gather honey and as merrily returned. 'Perhaps you would kindly show me how the hives were on the day of the funeral,' I said, 'and bring the cheese and ale and place them exactly as they then were.' Very gladly did she trip into the house and quickly returned with a small plate of ale, the bread and cheese swimming in the ale. One of these plates was placed on the alighting-board at the mouth of the hive, and this was how the hives stood on the day of the funeral when the deceased lady was taken to her last resting-place. 'But,' I said, 'the bees did not touch what was set for them.' 'Oh, yes, sir, they did,' replied my informer at once; 'they ate it all.' 'But you don't mean to say that they took the ale?' 'Yes, every drop.' I jocularly replied that they might all be drunk. On the day of the sale I purchased one of these hives still wearing its mourning habiliments; and if any of your readers would like to see these wonderful bees that have tasted the elixir of life, the present owner will be glad to afford such pleasure to any one who will call upon him. His house stands midway between Frodingham and Skipsa, on the right-hand side of the road.

When a hive swarms here a bell is rung. Often when the bees are 'up' you may hear the ringing, and this outward sign has a meaning which may not be known to your numerous readers. The bell rings to say, 'My bees are up,' so that if they should happen to alight in a neighbour's garden the owner may claim them. Should he neglect to ring the bell it is believed that he cannot claim them if they alight in another man's garden. Bee-keepers out here stick tenaciously to the straw skep, and many of them have never so much as seen your modern Association hive. Millions of bees are smothered here every year to get the honey. When I tell them the price of my new Association Standard hive they say, 'I could buy eight hives for that money.'—B. Ford.

#### FOUL BROOD AND CARBOLIC ACID.

In testing the curative power of phenol, the supposition that want of success in eradicating disease might be attributed to the use of a diseased queen was anticipated and found to be untenable. For on the 30th of August, when the virulently foul-broody stock was put under treatment, its outer comb was removed and given, with other clean empty ones, to a swarm of bees driven from a skep in which not a trace of foul brood could be found. This outer comb, being nearly filled with honey, contained only a few cells that had been used for breeding purposes, and these were all open and dried, save one sealed foul cell. Having extracted the honey and medicated it, as directed, by Mr. Cheshire's prepared phenol, I gave it to the driven bees along with 14 lbs. of medicated syrup. The weather being favourable and pollen abundant induced the queen to resume her maternal duties. On October 31st, I elevated one of the central frames, and saw two open foul cells amongst four or five square inches of sealed brood. As the day was windy and boisterous, I had to be content with a partial inspection. That, however, was sufficient to show the presence of disease; not, be it observed, in the tainted comb, where it might be rampant, but in a comb known to be clean when inserted.

With the view of giving phenol as administered by Mr. Cheshire the best chance of proving its virtue, I had foul combs, from which all putrid matter was removed by hand, given to a queen and bees personally selected from an apiary at a distance, in which disease does not now and never did exist. These combs, on the

30th ult., contained several square inches of sealed food brood, with empty cells interspersed. But frost and cold rendered a thorough examination of the hive inexpedient at present, and I am not disposed to rush to conclusions which the premises do not fully warrant.—*QUESTIONER, Nov.*

#### SPLIT TOP-BARS.

I think Mr. Hewitt rather sweeping in his remarks as to the evils of split top-bars. For many years I have used them, and long before they were ever sold with the saw-cut I used to saw mine down the middle and fix the foundation in by means of two screws, precisely as it is done now. If Mr. Hewitt finds that the wax-moth larvae take up their quarters in the cut—and of course they will—why doesn't he use a little putty over the foundations? We do not want any wax-spoons; but let us keep to the effective, quick, and easy way of inserting the foundation by means of the saw-cut and screws. I would guarantee to fill in fifty frames with putty in five minutes, so that no wax-moth, larva, or egg either for the matter of that, could possibly get in.

I have been a large bee-keeper in my time, and I am only too happy to come forward and defend the split bars, for I have never yet found anything to equal them, though at the same time I say 'Let us live and learn!'—*ALFRED E. BOOKER-HILL, The Chase, King's Lynn.*

#### SIMPLICITY IN BEE-KEEPING.

Every one who knows anything of bee-keeping will admit that one of the most serious hindrances to the bar-frame, and what is termed the advanced method, is the amount of time, care, and preparation it requires. Feeding is itself an art which requires the skill of an experienced cook, the patience of a Job, and the purse of a Crusus. To prepare a hive for an ordinary British winter demands as much care in the way of double sides, packing with sawdust, cushions, stuffing with bracken, or something of the sort, &c., &c., as though each hive were a ship being fitted for a North-Pole expedition. I say nothing as to such rubbish as india-rubber gloves, drone-traps, wire-veils, stings-blotters, gigantic honey-evaporators, queen-cages, rakes, foundation-hives, ditto cutters, winter-passage cutters, transferring-racks, distance-racks, and many other such unnecessary appliances. I never look over a catalogue of any of our chief hive-vendors without feeling indignant at the amount of money I, in common with many others, spent without cause in the early days of my bee-keeping. But *experientia docet*, as our classical friend Abbott used frequently to remark in the old *Journal*.

Now, I will give you my method of managing my small apiary, and if it opens the eyes of enthusiastic youngsters I shall be more than satisfied.

In the first place, I always drive a pair, *i. e.*, I have two hives for each colony. Both are down in the summer; only one in the winter. I find that from twelve to sixteen hives are as many as I require; or, indeed, can afford the time to look after in the summer. During the season I, of course, extract, double, and so on. When autumn draws near, I never dream of sneaking into the kitchen, like one of your correspondents, and in the dead of night keep the fires burning while I am boiling syrup. No, I advance my hives in couples near to each other, then some fine afternoon pour a few drops of essence of peppermint into each hive, followed by a puff of smoke, and quietly shake and brush the bees of one hive before the entrance of the other time about five minutes. If the hive which is to remain is short of stores—a rare event—I fill up with a few of the frames of the hive taken away—there will be plenty left for the extractor. So with the others, I

leave down eight hives, crammed with bees and honey, strong as lions, and I ready to swarm early in the spring. No feeding, no sticky syrup, no buying of sugar, no anxiety. The spare hives and frames are put by, the latter extracted, then the propolis scraped off, and the tops rubbed over with soap and hot water, containing a small quantity of strong ammonia. This removes all trace of propolis, and settles any grubs that may be in the frame-slits. The hives having been painted and cleaned during the winter months are in the spring taken into the orchard and substituted for those which have stood the storms of winter, giving me an opportunity of seeing the condition of the stocks, and the bees with fresh and wholesome homes. These winter hives are now renovated, and as the swarms arrive, they receive a hive filled with frames, all worked out with last year's comb. No feeding, no foundation, no candy, no mouldy pea-flour, no robbing; above all, very little trouble. I have taken about two cwt. of honey this year from twelve hives, and my total expense has been three and sixpence, which I gave for a dozen pounds of sugar my bees never received—for the best of reasons. Occasionally during the season my man and I have a big day at extracting, and we are glad when it is over. Sometimes we go in for artificial swarms, so called, but I prefer the natural on the whole. If one escapes now and then, well, good luck to it; 'tis an ill wind, &c., &c.

Now, a word as to hives. I am all for simplicity. Look at Bartrum's Knock-me-down Stewarton, Blow's Anglo-Cyprian, or Cowan's hive—look at the illustrations of the latter as 'packed for winter.' Look at the piles of rubbish shot all over top and sides. Look at the mysterious hollows with letters dotted all about. The summer arrangement equally fearfully and wonderfully made. And what for? Why, to shelter a stock of bees who are equally content with a hollow tree, without any special 'packing.' Beginners, beware of these wonderful hives! It is the bees that make the honey. I only use good, stout deal, an inch thick, for sides, half for top, and they hold sixteen frames when filled. I tried to get a well-known hive-maker to supply me with hives of the type described, and he replied, it is 'impossible' to make single sides for broad-shouldered frames! Mine are made thus:—They cover rest on a ledge, and just pass outside the ends of the frames—good high cover, capable of holding two rows of sections. No packing, only an extra cloth or two above frames, and I back them to pass through a Canadian or Arctic winter without flinching, and be lively enough when the golden crocus blooms. Spring feeding! If properly put up with sufficient stores they won't want it. Stimulate them! Do no such thing. Let them alone. They are the best judges when to breed, and at what rate. Don't be too clever. Drone-traps, too! What nonsense! Let the drones alone. Remember the humanitarian theory respecting burning bees. Why should you massacre the gentlemen? The bees know better than you do when to abolish their House of Lords.

Ligurians, Cyprians, Palestinians, Syrians, Carniolans, and other meridian bacilliferan foul-brooded foreign demons! When tempted, say, 'Get ye behind me, I'll keep to my honest, sober, hardy Britons.' I might say more, but I refrain, as I know I am but 'the voice of one crying in the wilderness.'—*JOHN PERK.*

#### BEE FLOWERS.

In late vols. of *British Bee Journal* and other works on bee-culture I do not find the common broom (*Cytisus separius*) and the bird-cherry (*Prunus padus*) mentioned as members of the bee-flora.

The bird-cherry flowers in May in long axillary racemes, the individual flowers not unlike a Hawthorn-bloom both in form and colour, and are easily accessible to bees. The flowering period lasts about three weeks,

and during that time bees are all day busy on the trees in vast numbers.

The broom is another valuable bee-flower coming in a little later than the bird-cherry. It produces a considerable amount of pollen, the bees in fact are literally covered with golden pollen-grains after visiting yellow-broom.—H. Y. DOMBE.

### BEE-KEEPING IN QUEENSLAND.

#### H. Visit to Messrs. Spry's, Flowerdale Apiary, Brisbane.

Through the introduction of Mr. Wright of the *Queenslander Newspaper*, I was kindly invited to visit the above gentleman's place, which is south from Brisbane about six miles. I gladly availed myself of the invitation on Thursday last, when I proceeded by bus for about five miles, where I was met by Mr. Spry with his trap, who drove us the remainder of the distance. As on my visit to Sweet Home Apiary, Captain H. accompanied me. Flowerdale may be said to be quite in the bush, surrounded on every side by a dense forest of gum, tea, and other honey-yielding trees, the site for the residence and apiary having only been cleared within the last two years. The ground is in the form of a square, containing about three acres, securely fenced by a high wooden paling. On entering the gate you are confronted by an array of square frame-hives painted in stone colour, and numbered consecutively from 1 upwards; these are all arranged in rows, and almost occupy the whole ground. The day being dull and threatening rain, there was not such a display of bees as we should have liked to have seen; as it was there was a very audible sound produced by bees on the wing. To give the day a chance of clearing up, Messrs. Spry in the first instance conducted us into their workshop and extracting room, where we had appliances shown and their uses very minutely described. First came the foundation machines (floor's), 6-inch and 10-inch, the description of which to your readers is unnecessary; next their timing apparatus; what with bolts, acids, tins made and in progress, gave it quite a tinsmith's workshop appearance, in fact it almost is such, as Messrs. Spry do a very considerable portion of their own tinsmith work; afterwards capping cans, wax drawers and extractors. In this room we were also shown a very neat Observatory hive, with glass super attached on top, which has been specially got up for the Exhibition here on 20th instant; this, however, cannot be called an Observatory hive proper, as it is neither more nor less than a Langstroth hive (made to suit their frames, 17 $\frac{1}{2}$  by 9 $\frac{1}{2}$  by 3) glazed on the four sides, through which a side of each of the outside combs and the ends of the frames can be seen; the same applies to the super, which is made for 1-lb. sections; these, however, Messrs. Spry do not use largely, as their demand is almost exclusively for extracted honey, which is put up in 1-lb. tins, with very neat labels in gold letters, and packed in 6-dozen cases for shipment to market. The samples of honey were very fine, of a very sweet taste and peculiar fragrance, altogether different from anything at home. Here, as formerly stated, the honey harvest extends over nine months, during which time last season this firm, from ninety stocks, sent out upwards of 11 tons of honey, for which they received almost 7000. Their stocks at present number 120, which they mean to increase till they have not less than 500. From the stocks they now have and their swarms they expect this season to have a revenue of close upon 20000.

Having seen the workshop, we inspected a few of the colonies, which were all beautifully clean, healthy, and in general good order. The bees are all pure Ligurians, Messrs. S. having great faith in them as honey-gatherers and best adapted for this climate. From my experience at home, and what I have since seen here, I hold to my old opinion, that first-cross hybrids are the best for all purposes. The hives are in the honey season wrought on

the storifying principle, often as many as five boxes being piled on top of each other.

Messrs. Spry are both promising young men, who only commenced bee-keeping about eighteen months ago, and deserve great credit for the energy with which they have gone into this profession.—JNO. WILKIE, *Arthur Terrace, Redhill, Brisbane, 6th Aug., 1884.*

### RECENT INVESTIGATIONS INTO THE STRUCTURE OF THE EGG ORGANS OF THE QUEEN.

By FRANK R. CHESHIRE.

(Continued from page 392.)

#### Egg Fertilising Pouch. Drone Eggs.

We have now reached a point immensely in advance of anything previously achieved, but the dissections are so exacting and the parts in question so minute and complex that I do not doubt but that some may fail in making the first and finding the second; while others, who have here succeeded may be unable to unravel the working of the muscles and valve previously described. And such experience has shown me many doubt my conclusions, such doubt being partly justified by the too common fashion of using the imagination more than the microscope. On this account and some others I have been exceedingly glad in receiving a visit from Mr. Cowan, to whom I had an opportunity of showing the two sets of glands, the double sphincter muscle,\* the muscle for opening the valve and the pair for propelling the glandular secretion and spermatozoa on their course, the nerve ganglion *in situ*, and many other parts, upon which I shall now have his corroboration.

To resume. If an egg be carefully removed from either a worker or drone cell by the wetted point of a camel-hair pencil, and then microscopically examined in water or glycerine, its surface will be found beautifully netted, almost as though a tiny pearl had been covered with what the ladies call 'blonde,' hundreds of meshes of which were required to coat it completely. Towards one end the netting makes its cells long and narrow, and pointing towards a circular spot, just as the coating of a balloon points towards the aperture by which the gas is allowed to escape. This circular spot is really an opening into the interior of the egg, and is called the 'micropyle.' At the time of fertilisation the active spermatozoon introduces itself at this micropyle and unites its material with the germ cell† derived from the queen. This fusion of the male and female elements gives origin to a worker which will possess qualities of both father and mother; and what children we must feel ourselves, how utterly baffled and confounded by the reflection that this tiny spermatozoon, eight or ten millions of which the queen may carry in her microscopic spermatheca, has about it somehow and somewhere that which shall determine, not sex merely, but all distinctions of species, such as the external form of the body, the length and modelling of the tongue, the arrangement of the pigment-cells, the colour of the covering plates, the tint of every hair, and the general temper and disposition of the resulting insect, besides a thousand other peculiarities. We speak of what the microscope has revealed, and without gainsaying it is surpassingly wonderful, but how little have we found compared with what lies behind! No scrutiny can detect a difference between the spermatozoon of the black, the Ligurian, and the Cyprian drone, but difference there must be, and yet this only opens a greater marvel in family resemblances, for the *why* of which all must be dumb.

The question as to how the spermatozoon finds the micropyle may well be asked. It does it, and there our knowledge ends, for the spermatozoon immediately after

\* Sphincter muscle—a muscle for shutting an aperture.

† Germ cell, the essential vital point of the egg.



the deposition of the worker-egg is found within. This puzzle, however, is not greater than that presented by every flower that blooms. The pollen placed upon the stigma immediately begins to throw out a thread-like tube, which grows down into the interior of the central organ, and here hidden travels on and on, seeking, and always finding, the tiny hole every seed possesses, which also in this case is called the micropyle. If a bean, after soaking in water for a few hours, be wiped, and then squeezed, a tiny drop will ooze from a spot near the end of the scar, which marks the attachment of the bean to its pod. This drop has passed from within through this aforesaid aperture, thus revealing its position. The micropyle once entered, the pollen-grain transfers its contents to the embryo, and so accomplishes the act of fertilisation in a manner closely resembling that of the egg which we are now considering. Some twenty-five years ago I worked with the late Mr. Woodward, of the British Museum, in investigating the fertilisation of ferns, and then had the opportunity of seeing something analogous to this, which but very few indeed have witnessed, the antherozoids (active threads, exactly resembling spermatozoa in function) wriggling and struggling, and at last entering the archegonium of the fern. The archegonium having a tiny aperture which is, again, quite analogous to the micropyle of the egg. How wondrously does a oneness, amidst infinite variety, present itself throughout nature!

We now see the necessity for the comparative narrowness of the spermatozoon head. It is that it should be able to pass the micropyle. But to effect this in so minute a time must be occupied, and how is this time gained? I think the following explains this completely. Just at the junction of the right and left oviducts, and a little above the commencement of the common duct, I find a pouch, which hitherto seems to have escaped observation. This pouch is dated over with very small spines, three or four lying together, and into this pouch the mixture of spermatozoa and glandular secretion is led by the upper fork of the spermatothecal duct (the lower fork, it will be remembered, I supposed to be the one by which the spermatic fluid is conducted to the spermatheca after ovulation). I find also very suggestively placed muscular fibres in the two oviducts, which during contraction must oblige the egg in process of passage downward to enter the pouch; and here I have no doubt fertilisation is accomplished, since the egg would be delayed and thus given for the entrance of the spermatozoon, but this is not all. If two more of the fibres are relaxed at once, three spines are led behind the pouch, giving passage to the egg, which is then conducted towards the ovipositor, and the egg being protected from all possible contact with spermatazoa, which I fully believe are confined to the pouch here described, remains unfertilised and produces as a consequence a drone. A voluntary contraction of the muscles next then, by which two muscles are relaxed, will convey the eggs being laid from works to drone form; and it is worthy of remark that this relaxation will necessarily tend to an increase in abdominal length, and so better allow the ovipositor to reach the base of the drone-cell. This explanation, at all points so satisfactory, removes another mystery, and is the complement of the evidence of Siebold's theories by supplying the long-needed anatomical confirmation of his position.

I am perfectly satisfied in reporting all that has gone before, but here, in detail at least, no over-positive assertion must be made, until many virgin queens have been examined, and of which next spring I can easily keep up a supply, my friends again, no doubt, kindly remembering me when useless ones are about.

+ It would afford me much pleasure to compare wasps and semi-solitary bees with hive-bees here, and any queen-wasps or dormant females I should receive very gratefully.

The nerve-structure of these several parts is most marvellous. The last large abdominal ganglion lies immediately beneath and in contact with the oviducts and spermatheca, and from it branches of nerves run in abundance into the oviducts, the spermathecal valve muscles, the sting, and ovipositor, while small ganglia are distributed in profusion, a considerable one lying over the valve and sending branches forward to the fertilising pouch. All this teaches that the whole genital system works in harmony like the parts of some complex machine, so that that which each section furnishes is yielded in time and quantity just as the work on hand demands. Oh, ho, ho, upon us! if we can be so dull and careless as to think of our bees as the farmer is said to have thought of the caterpillar when he described it as 'an ugly beast all skin and squash.' It might have been so to him perhaps, but it and our bees, too, are miracles of creative skill which to a better insight but thinly veil the Worker whose understanding is infinite, and we are not in our weakest moments when He, 'clearly seen by the things that are made,' draws us to bow the head and worship.

(To be continued.)

## Echoes from the Hives.

*Freshford, near Red'.* Of my two stocks No. 1 is a swarm of this year, which has yielded me 30 lbs., notwithstanding much blundering; No. 2 is a community of the old hive-lets. On opening them on the 28th Oct. to put all to rights for winter, I found a small patch of sealed brood in No. 2, while No. 1 had brood on three frames, and unsealed. They had been stimulated early in the autumn with dry sugar until the 7th, when I began to feed upon syrup. The cold weather earlier in the month led me to cut winter passages on the 14th; but owing to the influx of pollen and to my during the warm weather, which fell well, most of them had been closed up with sealed stops by the 25th. MARY HAYWARD.

*Keel, on the E. of A. Co. L.*—By the *Journal's* bee-keeping is looking up, I am very pleased to see the formation of a company for producing honey. As I believe it will do more for the permanent success of bee-keeping than any project that has been started. It has been in the great difficulty throughout how to dispose of the honey. I think I did you when I induced the beeskeepers in this locality, some thirty to forty years ago to improve methods of management, they used to bring their surplus stores of honey to me for sale. I was unable to take them, having no regular market for them, and it has been the great difficulty ever since; but I hope the proposed Honey Company will solve it. The past season has been a fairly successful, and I have a quantity of honey both run and in combs in sections by me. I have been interested in the papers by Mr. Chesley on foul brood, but I should like to have heard something more respecting the origin of it. You know 'Prevention is better than cure,' and if they could be managed without the liability to attacks of so serious a nature it would be desirable. AW. T. B.

*Keswick, Cumberland, Nov. 7.* The past season in this part of the country has been a splendid one for beekeeping. We have had the pleasure of reaping good harvests from our bees, particularly those that have taken up the bar-frame hive; but the latter are very thinly used as yet in this neighbourhood, as they are only becoming generally known. It will require time to convince many of them that they are behind the times, I find many of them very obstinate in their ideas, and cling to the 'straw hive'; whilst others are anxiously

\* Ganglia may be described as isolated masses of matter quite like brain in character.

inquiring about the frame-hive and its management. When they see the form in which the honey is taken and the bees saved, they naturally take a liking for it when all its advantages have been explained to them. Some I find so bigoted in their old notions that one may as well talk to a dog. Those I find to be the only people that won't allow their bees to be driven and saved from destruction. Others are the reverse. When they get to know that I would drive and save the bees, and then the trouble of destroying them over the brimstone-pit, they gladly let me have them for driving. Some were so pleased with the process of driving and the way in which the bees had been saved, that they wanted to pay me for my trouble. I told them I was already rewarded with the bees, but one lady bee-keeper insisted on me taking something. I thought this too good. She gave me three hives of condemned bees to drive. As I could only take two home with me, I united the third to a hive she intended to winter. After finishing the driving business we had a chat about bees and bee-keeping. She told me they have had the same bees or the same strain in their family for over eighty years. I thought this a wonderful thing, as most other bee-keepers had broken in the business. I thought this something worthy of note, as it showed that proper attention had been paid to them all through this length of time both in feeding and wintering. Many of them lose their bees through late feeding in this district. Honey at Keswick is much higher in price than most other places; the regular selling price is 2s. per pound, and not lower than 1s. 9d. for comb honey. I found good sale for my extracted honey at 1s. 4d. per pound, but the latter I did not go in for, only to empty a few combs now and then.—ROBERT PHILLIPSON.

*Hunts, Somersham, Nov. 21.*—The month of October was sufficiently mild to allow of feeding up to the end of the month, by which means many stocks were placed in good wintering condition. Where feeding has not been resorted to since the cessation of the honey flow after the storm in the early part of July, there has been a great diminution of stores, and late swarms are becoming very light. The weather of the present month has been too cold to allow of feeding. We have had several frosts, but the sharpest was this morning, when the thermometer in my summer-house stood at 24 Fahr. While on a visit to Mr. Howard, of Holme, Superintendent Alken, of Norman Cross, one of the numerous converts to the modern system Mr. Howard has made since he has been at Holme, drove us to Stamford on Nov. 8th for the purpose of paying a visit to the apiaries of Messrs. Sells, of Uffington. The short space of an 'echo' will not allow me to say all I should like to say about our visit, but I would say that we had a thoroughly enjoyable outing, and were very pleased with our visit to Messrs. Sells.—C. N. WHITE, Hon. Sec. *Hunts B. K. A.*

*Dunbar, Kirklandhill, Nov. 7th.*—I beg to enclose my honey harvest report for this season. From one stock in straw skep and its two swarms, one lived in straw skep and the other in Stewarton, I took 90 lbs. of comb-honey, and the hives left in good condition for wintering.—GEORGE D. CLARK.

**CERTIFICATES AT READING SHOW.**—Third-class Certificates were awarded to the following Candidates at the Examination held at Reading on October 1st, viz.:—

- H. Fretwell, Cumberland Road, Reading.
- Walter B. Webster, Market Place, Wokingham.
- Harry Colby, Wargrave, Henley-on-Thames.
- Thomas E. Adams, Culworth, Banbury.
- Thomas S. Cambridge, Aldermaston, Reading.

**HUMBLE BEES FOR NEW ZEALAND.**—Alfred Neighbour, 149 Regent Street, London, writes:—My letter inserted in your issue of October 15th, in which I asked

for torpid humble bee queens, has been so numerously responded to that I now have as many as I need, so take this opportunity of stating that I am unable to receive more at present.

## NOTICES TO CORRESPONDENTS & INQUIRERS.

**J. P.—*Spraying Combs.***—The mixture we use for this purpose consists of the ordinary carbolic acid sold by the chemists—one part to nineteen parts of water. The water should be hot, and the mixture well shaken before spraying. To wetting the combs, at this late season, we should prefer to fumigate with sulphur before storing them.

**G. L.—*Temperature of Brood-nest.***—95 degrees Fahr. See letters of 'Amateur Expert' and G. D. Haviland in our issues of June 1st, June 15th, and August 1st, of the present year, wherein this subject is fully treated.

**F. L.—*Sugar Syrup.***—It is presumed that your query refers to the answer given to 'W. M. M.' in the issue of September 15th where it is stated that 5 lbs. of sugar to one quart of water are equal to about 3 lbs. of honey. The latter figure, 3, is an error, either printer's or a *lapsus calami*. It should have read '5 lbs.' as we consider, in actual practice, that the weight of the water used in making the syrup—should be deducted, since greater part is evaporated by the bees before the food is sealed over. Also in providing a stock with its winter food, allowances should be made for granulation, to which sugar-syrup is much more liable than well-ripened honey, and granulated sugar-syrup, in our experience, is never consumed by bees.

**W. H. J.—*Doubling.***—By all means experiment on your proposed plan, if you feel so inclined. To us it appears complicated. There is no real necessity for using zinc-excluder between the hives, although many American apiarists do, since if the combs of the upper hive are extracted sufficiently often, during the honey flow, and the brood-nest below is large enough, there is no fear of brood in the upper hive. See Mr. Cowan's advice on 'Doubling' in his *Bee-keepers' Guide*, p. 54. Although the bees will fix the zinc-excluder with propolis it is easily removed, and with little disturbance, on a fine day when the bees are at work. 2. The angle at which the alighting-board is pitched, if not too great, is no disadvantage to the bees. Many apiarists, however, who prefer it horizontal use very finely perforated zinc, which allows the water to escape and is of no detriment to the bees.

**C. M. R.—*Candy Feeding—Crown Boards—Winter Passages.***—We never attempt to winter one colony of driven bees alone, always putting two and sometimes three, or even four small colonies together. As you do not state the quantity of syrup supplied to the bees, we cannot advise you as to the probability of their wintering. Crown-boards have entirely gone out of use of late years, their place being supplied by the quilt, which is easily raised, and the candy placed over the frames, with little disturbance of the bees. If your bees have enough food to last until February, do not feed them at present. 2. Winter passages are an advantage, especially when the frames are quite filled with comb, in which case the bees are compelled to pass round the ends of the frames, but this rarely happens, and it is quite likely that your bees will winter well without them. Do not paint your hives until spring arrives. Perfect rest should be allowed the bees during the winter months.

**G. H. D.—*Nyctel Greena, N. Birmingham.***—The queen appeared healthy, and careful dissection showed her to be completely so. The workers did not show any sign of disease, but the cells you thought suspicious

unfortunately are full of *bacillus alvei*. You need not take any steps until the spring. The time of the outbreak is singular. Many thanks for the queen.—F. C.

A. J. C., *St. Ebbs, Oxford*.—The queen arrived alive, that is, she revived when placed in a warm situation, and fed then freely. She was extremely diseased. One ovary completely broken down. In the workers were millions of small *Bacilli*, almost certainly *Cryptoi*, but I would not pronounce absolutely without making a cultivation which there was no opportunity of doing. The queen will be of much service for future reference. F. C.

C. POLAND.—*Bee Working*.—Yes. Your bees are evidently strong, and as pollen has been recently carried in there is probably brood, which, as they are well packed up, will hatch out.

YOUNG BAR-FRAME.—1. *Thickness of Back and Sides of Hive*.—Because by the system of packing bees at the back of the hive with a dummy in front forming practically a double wall it is not necessary that the hive itself should have one, while at the sides double walls are necessary, but they may be warm inside so that the bees can pass round the frames and without becoming chilled. 2. *Mounting of Frames*. Plain frames are those made of four pieces of wood all of the same width with no lateral projections; these frames require to be spaced by the practised eye of the bee-keeper. Not very easy to a beginner. Wide-shouldered frames are, as their names implies, those which have wide shoulders which come one against the other keeping the distances from centre to centre of frames correct. Wide-sided frames have the end bars or sides widened so as to touch those on either side, forming a kind of inner-wall to the hive. They are strongly recommended by at least one eminent bee-keeper, but they are not generally approved of. On the balance of advantages and disadvantages, the

wide-shouldered frames are generally admitted to be the best and most convenient for manipulation. 3. *Time when Drones Fly*.—No; they fly when six or seven days old. 4. *Frames covered by Bees*.—A stock covering ten frames at beginning of May would be a 'very' strong stock. If seven or eight are covered at that season the stock is a strong one.

AN INFANT BEE-KEEPER. *Robbing*.—All the drones would normally have disappeared long before the date you name. We have, frequently, in our 'Useful Hints' and otherwise, given cautions against spilling syrup about, and the robbing was only what you might have expected. The robbers, no doubt, came from some of your neighbour's hives. The appearance of the slain is quite usual.

M. T.—With open country surrounding you, you may keep forty or fifty stocks without danger of overcrowding.

YOUNG APRIANUS.—1. *Provision for taking away Cuck-dust*.—In some hives with loose floor-boards, by lifting the hive off the floor-board the packing falls out. In others it is enclosed permanently. 2. *Stands*.—Stands may be formed of four stakes driven into the ground, or four flower-pots, or a regular framed stand may be used if expense is no object. 3. *Covering Roofs*.—Zinc is by far the best material for covering roofs. It requires no paint, and lasts for years.

A COLIAGE BEE-KEEPER. *Moving Bees*. You may move your bees the entire distance at once by the plan you name.

A COLIAGE BEE-KEEPER. Mr. Cheshire's paper on the 'Philosophy of Hive Shape' has not been published in a separate form. It will be found in Vol. II., p. 76.

C. T. *Refusing Wax*. Please refer to 'Useful Hints,' p. 111.

# THE BEE & FRUIT FARMING COMPANY, LIMITED.

*Incorporated under the Companies' Acts, whereby the liability of each Shareholder is limited to the amount of his Shares.*

CAPITAL £10,000, divided into 10,000 SHARES of £1 each,  
Payable 5s. on Application and 5s. on Allotment, and the balance when required.

*In case of no Allotment all Deposits will be returned in full.*

## DIRECTORS.

JESSE GARRATT, Esq., Hockenden, St. Mary Cray, *Managing Director*.

LAWRENCE GREEN, Esq., Tovil House, Maidstone.

JOHN M. HOOKER, Esq., Sevenoaks.

FREDERICK H. JUDSON, Esq., Coventry Park, Streatham, S.W.

JOHN MARTEN, Esq., Dunkirk House, Faversham.

HENRY GRAVE MORRIS, Esq., Belmont Hill, Lee, S.E.

SOLICITORS.—MESSRS. ASHURST, MORRIS, CRISP & Co., 6 Old Jewry, London, E.C.

BANKERS.—MESSRS. GLYN, MILLS, CURRIE & Co., 67 Lombard Street, London, E.C.

SECRETARY (*pro tem.*)—MR. F. M. EDWARDS,

OFFICES.—DERRY DOWNS, ST. MARY CRAY.

**DR. PINE'S**

**Registered Removable Metal Frame Ends.**

*Price Medal, B.B.K.A., 1882; and numerous other Prizes.*

BY the use of this valuable invention the making of Frames is simplified. No metal runners are required, all systems of frames are rendered interchangeable, and propolization is reduced to a minimum.

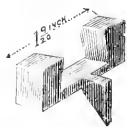

Unfortunately, as is the case with all inventions of merit, numerous substitutes are being introduced under the name of 'improvements.' But there is not one of these so-called 'improvements' which does not possess defects from which the original invention is free.

It is, therefore, absolutely necessary when ordering Hives to specify that the Frames are to be fitted with **DR. PINE'S ENDS,** and with no others. All Hive-makers will supply Hives fitted with them, and generally without extra charge, the small cost being saved in diminished cost of labour.

Price of the Ends, 1s. per doz. or 10s. per gross.

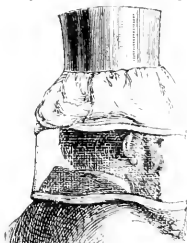

**DR. PINE'S Woven Wire Veils.**

*Price Medal, B.B.K.A., 1879.*

Do not confine the breath, do not obstruct the sight, and cannot be blown against the face or ears.

Price 2s. 6d. each.

**DR. PINE'S BEE-KEEPERS' LOTION**

Is the acknowledged Remedy for Stings, especially for removing the subsequent inflammation. Price 1s. 6d. per bottle.

*The above Inventions may be obtained from*

Messrs. NEIGHBOUR & SONS, Regent St. & Holborn, London  
And from all respectable Dealers in Bee-keepers' Requisites.

*Dealers may obtain Wholesale Prices from the Inventor,*  
**MR. F. LYON, 94 Harleyford Road, London, S.E.**

**J. H. HOWARD,**  
MANUFACTURER.

HOLME, near PETERBOROUGH.

ASSOCIATION STANDARD BAR-FRAMES, 1s. per doz. SIMMINS' HIVES, CRATES, SECTIONS, and DRY SUGAR-FEEDERS, water provisioned or otherwise. Catalogues free. (82)

**CHESHIRE HIVES AND APPLIANCES.**

SOLE APPOINTED MARK—

**W. HOLLANDS,**

HARRISON RISE, CROYDON

PHENOLATED CANDY CAKE, for Autumn and Winter use, as recommended by Mr. CHESHIRE on page 337 of *B. B. J.* Price 6d. per lb.; 6 lbs., post free. 4s.

CHESHIRE QUEEN CAGE.—The very best for introducing. Price 6d., postage 1d.

**THE CHESHIRE CURE FOR FOUL BROOD,** Supplied by Mr. Cheshire, with full directions for use. Price 1s. 6d. per bottle, postage 2d.

*The Trade supplied on the most liberal terms. Price Lists on application.*

**THE**

**CHESHIRE CURE FOR FOUL BROOD**

Is Prepared for Mr. Cheshire, under his Personal Guarantee, by

**MR. LYON,**

94 HARLEYFORD ROAD, LONDON, S.E.,

WHO WILL SUPPLY IT,  
ACCOMPANIED BY FULL DIRECTIONS FOR USE.

Price 1s. 6d. per Bottle, postage 2½d.

**PHENOLATED SOAP**

Contains 15 per cent. Absolute Phenol, specially prepared for Disinfecting Hives.

Price 6d. per Tablet, postage 2d.

A liberal discount for quantities of one dozen and upwards to Secretaries of County Associations and to Dealers.

**SPECIALITIES**

TO BE OBTAINED FROM

**THOS. B. BLOW, Welwyn, Herts.**

**ABSOLUTE PHENOL**

GUARANTEED CHEMICALLY PURE.

(MR. CHESHIRE'S REMEDY for FOUL BROOD)  
EITHER IN CRYSTALS OR SOLUTION.

With full Instructions, 1s. 6d. per bottle, postage 2½d.

**PHENOL SOAP,**

For Cleansing Hives, 6d. per cake, postage 2d.

**BLOW'S REMEDY FOR BEE STINGS,**

1s. 6d. per bottle, postage 2½d.

**BLOW'S REMOVABLE METAL ENDS,**  
For BAR FRAMES.

The best in the market, 1s. per dozen.

**BLOW'S WIRE AND NET VEILS.**

Will not Rust, 2s. 6d. each, postage 2½d.

**THOS. B. BLOW, Welwyn, Herts.**

Wholesale & Retail of  
**W.P. MEADOWS,**  
Manufacturers of  
BEE APPLIANCES  
System  
or  
Inventor  
of  
**J. DINES & SON,**  
Melbourn, Essex.

Wholesale & Retail of  
**W.P. MEADOWS,**  
Manufacturers of  
BEE APPLIANCES  
System  
or  
Inventor  
of  
**J. DINES & SON,**  
Melbourn, Essex.

*The Bazaar Feature*  
For description see Journal May 1884

# THE BRITISH BEE JOURNAL



AND BEE KEEPER'S ADVISER.

REGISTERED AS A NEWSPAPER FOR TRANSMISSION ABROAD.

[ENTERED AT STATIONERS' HALL.]

PUBLISHED ON THE 1st AND 15th OF EVERY MONTH.

[No. 146. Vol. XII.]

DECEMBER 15, 1881.

[Price 3d.; post-free, 3½d.]

GATHER HONEY FROM YOUR FLOWERS.

## NEIGHBOURS' CELEBRATED BEE-HIVES,

For taking Honey without Destroying the Bees.

SILVER and other MEDALS awarded at following Exhibitions: London, 1851, 1852, and 1873; Paris, 1855, 1867, and 1878; Philadelphia, 1876; Dublin, 1873, 1880; Chicago, 1880; Edinburgh Show of Calistonian Society, Silver Cup, 1877; also at all Shows of the British Bee Association, &c.

### NEIGHBOURS'

#### Improved Cottage Bee-Hive,

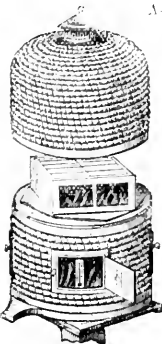

At originally introduced by GEORGE NEIGHBOUR & SONS, working under Three Bell Glasses, or tray of Sectional Supers, as represented in a novel engraving. It is neatly and strongly made of brass, and has Three Windows in the lower Hive. This Hive will be found to possess many practical advantages, and is in no way of management than any other Bee-hive that has been introduced.

The above recommendations, combined with its rustic appearance in the garden, render this Hive an excellent favorite.

When ordering it is desired to specify whether Glasses or Sections are preferred.

Price, as exhibited £1 15 0  
Stand for ditto ... 0 10 6

### THE GUINEA BAR-FRAME HIVES.

The above is placed in a compartment, which has a two-way opening, and is fitted with a sliding door, which can be opened or closed at will. The honey is taken from the top of the hive, and the bees are allowed to enter and leave at will. The honey is taken from the top of the hive, and the bees are allowed to enter and leave at will. The honey is taken from the top of the hive, and the bees are allowed to enter and leave at will.

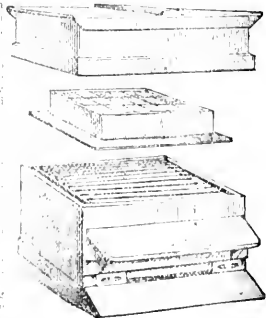

### DOUBLE WALLED HIVES, with Cork Dust or Chaff between.

Comb Foundation, Smokers, Sections, and all requisites for Bee-culture of own and Foreign Manufacture.

Importers of ITALIAN, CARNIOLEAN, CYPRIAN, SYRIAN, and all FOREIGN BEES. ENGLISH BEES also supplied.

'THE APIARY,' by Alfred Neighbour, price 5s.

'AN ESSAY ON BEES,' by W. Thomson, known as 'The Lanark Bee-keeper,' and Apiculturist Contributor to *Journal of Horticulture*. Price 6d., free by Post 7d.

### LIMNANTHES DOUGLASSII.

Now is the right time for planting this excellent Honey-yielding Plant. Price per thousand, 8s. 6d.; per hundred, 1s. 3d. Also *Arabis Alpinus*, 1s. 6d. per hundred. Packing included from Exmouth Station, L. & N.W. Railway. G. N. & Sons have been awarded Silver & Bronze Medals for Bee-hives & Honey at the International Health Exhibition. A newly arranged Illustrated and Priced CATALOGUE sent on receipt of Two Stamps.

CHESHIRE'S CURE for FOUL BROOD, 1s. 6d. per bottle, free by Post 1s. 8½d.

GEO. NEIGHBOUR & SONS, 127 High Holborn, W.C.; or 149 Regent Street, W., London. (1)

CONTENTS.

<b>EDITORIAL, NOTICES, &amp;c.—</b>	<b>PAGE</b>	<b>CORRESPONDENCE (continued)—</b>	<b>PAGE</b>	<b>FOREIGN:—</b>	<b>PAGE</b>
End of Volume the Twelfth ... ..	426	The Awards at the Heatheries.—Silver	124	Switzerland—France ... ..	439
The British Honey Company ... ..	426	Medal to Abbott Brothers ... ..	124	<b>ECHOES FROM THE HIVES —</b>	<b>439</b>
Notice to Secretaries ... ..	428	Foul Brood ... ..	124	<b>NOTES TO CORRESPONDENTS:—</b>	
Blight Competition, 1884-5 ... ..	428	Foul Brood: its Cure by Fasting, with-		Sugar — Small Portions of Wax —	
Cheshire Fand ... ..	428	out the use of Drugs or Chemicals.		Enamelled Cloth — Thin Honey —	
Reading-book for Schools on Bee-		By D. A. Jones, Canada ... ..	124	Extractor — Cyprians and Syrians	
keeping ... ..	428	Price of Honey ... ..	125	— Granulation of Sections — Moving	
Notts Bee-keepers' Association ... ..	428	Query on the Production of Extracted		Bees — Roofs — Candy — Preventing	
Recent Investigations into the Structure		Honey ... ..	126	Crystallization — Dry Sugar Feeding	
of the Egg Organs of the Queen. By		Judging ... ..	126	— Mr. Simmins's Hives — Queen-	
F. R. Cheshire ... ..	429	Royal Agricultural Society for 1885 ...	126	rearing — Section-Rack — Trans-	
Paper for next Conversation ... ..	430	Humble Bees for New Zealand ... ..	126	ferring from Skeps to Frame-hives—	
<b>ASSOCIATIONS:—</b>		The Peel Testimonial Fund ... ..	127	Ligurians — Scotch Bee-keepers —	
Chelmsford, Essex — Notts — North-		Notts Bee-keepers' Association ... ..	127	— Sulphur Fumes — Wax-moth — Com-	
east of Ireland — Irish — Cheshire:		Bee Census ... ..	127	mencing Bee-keeping in Africa... ..	439
Cheadle, Davenhams ... ..	430	The Honey Yield of 1884 ... ..	127		
<b>CORRESPONDENCE:—</b>		Improving Honey for Market ... ..	128	<b>TITLE.</b>	
Queen Introduction ... ..	432	Editorial Ignorance ... ..	128	<b>INDEX.</b>	
In a Bee-house ... ..	433	Bee-keeping in Scotland ... ..	128		
		Worth of Sections.—Scrapers ... ..	128		

SUBSCRIPTIONS and ADVERTISEMENTS.

ALL Communications relating to Subscriptions and Advertisements are sent to JOHN HUCKLE, King's Langley, Herts, not later than the 11th and 20th of each month.

Annual Subscriptions, twelve months 7s., six months 5s. 6d.

Remittances should be made by Post-office Order, Cheque or Postal Order, if Stamps are sent Halfpenny ones are preferred.

Post-office Orders to be made payable at the King's Langley Post Office. Cheques to be crossed "Bucks and Oxon Bank." Postal Orders should not be crossed.

Special Terms to Bee-keepers' Associations.

SCALE OF CHARGES FOR ADVERTISEMENTS.

<b>SINGLE COLUMN:—</b>	<b>£ s. d.</b>
Three lines ... ..	0 1 6
Per line afterwards ... ..	0 7 6
Half do. ... ..	0 2 6
Quarter do. ... ..	0 8 0
Half do. ... ..	0 15 0
Whole do. ... ..	1 5 0
<b>DOUBLE COLUMN:—</b>	
Page ... ..	2 10 0
Half do. ... ..	1 7 6
Third do. ... ..	1 0 0
Quarter do. ... ..	0 17 6

Special Terms for Displayed and Continuous Advertisements. Bee-keepers' Associations and Shows are charged at reduced rates.

NOTICE.

The British Bee Journal is published by KENT & CO., 23 Paternoster Row, and may be obtained of all local Booksellers, and of the following Agents:—

- ABBOTT, BROS., Fairlawn, Southall.
- BALDWIN, S. J., Stanley Road, Bromley, Kent.
- BLOW, T. B., Welwyn, Herts.
- BROWN, C., Bewdley, Worcestershire.
- COCKBURN, A., Cairnie-by-Keith, N.B.
- DURRANT & Co., Booksellers, High St., Chelmsford.
- EDEY & SONS, St. Neots, Hunts.
- EDMONDSON BROS., Dame Street, Dublin.
- HOLLANDS, W., Harrison Rise, Croydon.
- HOLE, J. R. W., Tarrington, Ledbury, Herefordshire.
- JOHNSTON, A. B., Brickhall, Ballywoolen, Killybegh, Co. Down.
- MCNALLY, R., Glenluce, N.B.
- NEIGHBOUR & SON, 149 Regent Street, and 127 High Holborn, London.
- OVERTON, C. T., Three Bridges, Sussex.
- REDSHAW, C., Welford Road, Leicester.
- RICE, J. J., Wensum Street, Norwich.
- SMITH & SON, 156 Strand, London; and at all Railway Bookstalls.
- WALTON, E. C., Muskharn, Newark.
- WREN, L., 139 High Street, Lowestoft.

We desire to give every facility to the Public for obtaining the Journal, and our Readers will notice that Special Agents (as above) have been appointed for its sale. The names of other Agents will be added to this list from time to time.

Subscribers who may wish to have the Journal sent direct from our Office by post may do so by payment of their Subscriptions in ADVANCE, and may rely upon its being promptly despatched by the next post after publication. An Order Form for the renewal of Subscriptions accompanies the Journal at the expiration of the Subscription. The Expire is also indicated by the Journal being sent in a Coloured Wrapper. It is indispensable that a renewal of the Subscription should be made previous to the issue of the next number.

JOHN HUCKLE, Manager Subscription & Advertisement Department.

Fifth Edition. Ninth Thousand.

**BEE-KEEPERS' GUIDE BOOK.** Containing Management of Bees in Modern Moveable Comb Hives, and the Use of the Extractor. By THOS. W. COWAN, F.G.S., F.R.M.S., &c. With numerous Illustrations. Fcap. 8vo., price 1s. 6d.; or in cloth gilt, 2s. 6d. Postage 2d. To be had of Houlston & Sons, Paternoster Square, all Hive-dealers, and Secretaries to Bee-keepers' Associations. 380

ISAAC HALE'S BAR-FRAME HIVE.

British Bee-keepers' Association size, made of one-inch well-seasoned wood; Cover tongued and screwed; Floor-board. Ten Frames, with wide sides to economise heat; waxed to ensure straight Combs; half-inch space between the top bars, covered by Quilt, to examine at any time without disturbing the Bees; Excluder Zinc, to confine Queen to the first five bars, and prevent Worker Bees storing pollen in the last five. Division-board for contracting space in the hive; Flight-hole in floor-board. Well painted, 7s. 6d. each. Not published and painted, 5s. Directions for Management. 1d. ISAAC HALE, Maker, HORSCASTLE.

BALDWIN'S

NEW CATALOGUE contains more sound information than any other. All Illustrations from Photography, so can be relied upon. Well worth 6d., sent post free for 2d. stamps.

**S. J. BALDWIN, Expert-in-Chief, BROMLEY, KENT.**

**BEE-KEEPERS' GUIDE; OR, MANUAL OF THE APIARY.** 11,000 sold since 1876. 12th Thousand just out. 10th Thousand sold in just four months. 2000 sold the last year. More than fifty pages, and more than fifty costly Illustrations, were added in 8th Edition. The whole work has been thoroughly revised, and contains the very latest in respect to Bee-keeping. Price 5s., postage 4d.

BEE JOURNAL OFFICE, KINGS LANGLEY.

**BRITISH BEE KEEPERS' PRACTICAL NOTE BOOK.** By THOMAS W. COWAN, F.G.S., F.R.M.S., &c. Crown 8vo. boards. 1s.; postage 1d. Indispensable for every Bee-keeper. Published by J. HUCKLE, Kings Langley; may also be obtained of all Hive-dealers.

**PURE RUBBER STAMPS**

USEFUL FOR

<p>HONEY LABELS</p> <p>Note Paper</p> <p>ANY DESIGN</p> <p>with Bee</p> <p>INCLUDING</p> <p>T. SELLS</p> <p>UFFINGTON</p>	<p>FOR</p> <p>SECTIONS</p> <p>Headings, &amp;c.</p> <p>OR WORDING</p> <p>from 2/-</p> <p>Each Pad, Ink, &amp;c.</p> <p><b>THE APIARY</b></p> <p>STAMFORD</p>
---	--

PRICES ON APPLICATION.

BEE FLOWERS.

**PLANT OUT NOW for Early Spring.**—Arabis, Linnanthes, Wallflower. Strong Plants, 1s. 6d. per 10, free. Address S. S. GOSWORTHY, Boxworth, St. Ives, Hunts. (51)

**DR. PINE'S**

**Registered Removable Metal Frame Ends.**

*Prize Medal, B.B.K.A., 1882; and numerous other Prizes.*

By the use of this valuable invention the making of Frames is simplified. No metal runners are required, all systems of frames are rendered interchangeable, and propolization is reduced to a minimum.

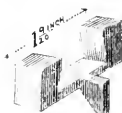

Unfortunately, as is the case with all inventions of merit, numerous substitutes are being introduced under the name of 'improvements.' But there is not one of these so-called 'improvements' which does not possess defects from which the original invention is free.

It is, therefore, absolutely necessary when ordering Hives to specify that the Frames are to be fitted with 'DR. PINE'S ENDS,' and with no other. All Hive-makers will supply Hives fitted with them, and generally without extra charge, the small cost being saved in diminished cost of labour.

Price of the Ends, 1s. per doz. or 10s. per gross.

**DR. PINE'S**

**Woven Wire Veils.**

*Prize Medal, B.B.K.A., 1879.*

Do not confine the breath, do not obstruct the sight, and cannot be blown against the face or ears.

Price 2s. 6d. each.



**DR. PINE'S BEE-KEEPERS' LOTION**

Is the acknowledged Remedy for Stings, especially for removing the subsequent inflammation. Price 1s. 6d. per bottle.

*The above Inventions may be obtained from*

Messrs. NEIGHBOUR & SONS, Regent St. & Holborn, London And from all respectable Dealers in Bee keepers' Requisites.

*Dealers may obtain Wholesale Prices from the Inventor, MR. F. LYON, 94 Harleyford Road, London, S.E.*

**J. H. HOWARD,**

MANUFACTURER.

HOLME, near PETERBOROUGH.

ASSOCIATION STANDARD BAR-FRAMES, 1s. per doz. SIMMINS' HIVES, CRATES, SECTIONS, and DRY SUGAR-FEEDERS, water provisioned or otherwise. Catalogues free. (12)

**CHESHIRE HIVES AND APPLIANCES.**

SOLE APPOINTED MAKER

**W. HOLLANDS,**

HARRISON RISE, CROYDON

PHENOLATED CANDY CAKE, for Autumn and Winter use, as recommended by Mr. CHESHIRE on page 337 of B. B. J. Price 6d. per lb.; 6 lbs., post free, 1s.

CHESHIRE QUEEN CAGE. — The very best for introducing. Price 6d., postage 1d.

**THE CHESHIRE CURE FOR FOUL BROOD,** Supplied by Mr. Cheshire, with full directions for use. Price 1s. 6d. per bottle, postage 2d.

*The Trade supplied on the most liberal terms. Price Lists on application.*

THE

**CHESHIRE CURE FOR FOUL BROOD**

Is Prepared for Mr. Cheshire, under his Personal Guarantee, by

**MR. LYON,**

94 HARLEYFORD ROAD, LONDON, S.E.,

WHO WILL SUPPLY IT,

ACCOMPANIED BY FULL DIRECTIONS FOR USE.

Price 1s. 6d. per Bottle, postage 2d.

**PHENOLATED SOAP**

Contains 15 per cent. Absolute Phenol, specially prepared for Disinfecting Hives.

Price 6d. per Tablet, postage 2d.

A liberal discount for quantities of one dozen and upwards to Secretaries of County Associations and to Dealers.

**SPECIALITIES**

TO BE OBTAINED FROM

THOS. B. BLOW, Welwyn, Herts.

**ABSOLUTE PHENOL**

GUARANTEED CHEMICALLY PURE.

(MR. CHESHIRE'S REMEDY for FOUL BROOD) EITHER IN CRYSTALS OR SOLUTION.

With full Instructions, 1s. 6d. per bottle, postage 2d.

**PHENOL SOAP,**

For Cleansing Hives, 6d. per cake, postage 2d.

**BLOW'S REMEDY FOR BEE STINGS,**

1s. 6d. per bottle, postage 2d.



**BLOW'S REMOVABLE METAL ENDS,**

For BAR FRAMES.

The best in the market, 1s. per dozen.

**BLOW'S WIRE AND NET VEILS.**

Will not Rust, 2s. 6d. each, postage 2d.

THOS. B. BLOW, Welwyn, Herts.

Wholesale & Retail of W.P. MEADOWS' Bee Appliances. The Rayner Feeder. For description, see Journal, May 17, 1884. J. DINES & SON, Maidens, Essex.

**ABBOTT BROTHERS,**  
**MANUFACTURERS of BEE-HIVES, COMB FOUNDATION, &c.,**  
Inventors of most Appliances now in use  
in the Bee World,  
**SOUTHALL, NEAR LONDON,**

**B**EG to inform the Public that they intend adding to their Catalogue for 1885, as a speciality, a **TOOL CHEST**, containing all first quality well-selected Tools that are necessary for Hive-making, &c. Any Tools that are of extra value to Bee-keepers they intend having specially manufactured.

**ABBOTT BROTHERS** were induced to offer this Collection through meeting Special Terms from a noted Sheffield Firm, and as they contemplate a large sale of the same, they hope to give the Public any benefit that may be derived from buying in quantity.

The working of all the machinery lately erected has been so thoroughly satisfactory that all the Warehouses are already overstocked, **ABBOTT BROS.** therefore advise Manufacturers and Dealers to apply at once for **SPECIAL TERMS** for their **FOUNDATION, SECTIONS, &c.**

The largest Consignment of **SECTIONS** ever imported into England is now on its way to **SOUTHALL**, and judging from samples they are the finest quality Sections ever imported.

**PROFESSOR HEHNER** drew special attention to their **BEES-WAX**, after carefully analysing Samples of all qualities, and reported all **ABSOLUTELY PURE**; showing that their Markets are good, and that they use the proper amount of caution in buying.

---

*CATALOGUE for 1885 will soon be Ready, FREE.*

---

**ABBOTT BROTHERS** beg to thank their Patrons for all past favours, and hope that the attention given to all their Orders will ensure their recommendation.

---

**FAIRLAWN, SOUTHALL.**



# THE BRITISH BEE JOURNAL

Communications to the Editor to be addressed 'STRANGEWAYS' PRINTING OFFICE, Tower Street, St. Martin's Lane, W.C.'

[No. 160. VOL. XII.]

DECEMBER 15, 1884.

[PUBLISHED FORTNIGHTLY.]

## Editorial, Notices, &c.

### END OF VOLUME THE TWELFTH.

The conclusion of a volume brings us into closer relationship with our readers. It gives us an opportunity of tendering our sincere thanks to our many friends who have during the year favoured us with their patronage and assistance; and it enables us to acknowledge the numerous testimonies we have received of sympathetic appreciation of our labours and of approval of the mode of conduct of the *Journal*. Though our thin volume has, in consequence of its bi-monthly appearance, extended to a portly tomo of 140 pages, and though our space has thereby been considerably augmented, it has scarcely permitted us to keep abreast with the many contributions which have been forwarded to us; and in many instances we fear that we have considerably trespassed on the patience of our contributors by the postponement of the appearance of their letters. We have endeavoured to avoid this to the extent of our ability, and we trust that our kind friends will hold us in this excused. A glance at the index which accompanies this number will show the great extent and variety of the work before us. Apiculture is developing in every direction, and the present year has been one of considerable interest and importance. It has been one of prosperity to all bee-keepers. For many months the Bee Department of the International Exhibition has been open and has been visited by many thousands, and its educational value has been great. The Honey Company—the offspring of the honey season of this year—is now being formed, and will prove of great assistance to both honey consumers and honey producers, and we shall feel a deep interest in its progress.

We hope that during the coming year we may be favoured with a continuance of the assistance hitherto given to us, and it will be our constant endeavour to promote every scheme which has for its aim the advancement of bee-keeping. We trust that the season of 1885 may be as prosperous to bee-keepers as that of 1884. And we take this opportunity of wishing all our readers and friends a cheerful Christmas and a happy New Year!

## THE BRITISH HONEY COMPANY.

In our issue of October 15th we endeavoured to shadow forth the necessity of a Honey Company,—the growth, in a great measure, of the grand honey season of 1884. We also sketched the method in which we considered the Company should be worked, as also the objects to be aimed at, and the difficulties to be overcome. We are pleased to note that since the appearance of our remarks the Company has been making steady progress, and is rapidly becoming an accomplished fact; and as it continues to fulfil what it seems to be approaching the ideal we then portrayed.

On the 28th ult. a fair representative meeting of the promoters was held at 105, Fenchurch Street, the chair being occupied by Lord Sudeley, whose fruit and bee farm were described at some length in our last issue, and who, as one of the largest bee-keepers in England, takes a marked and a warm interest in the success of the Company. Lord Sudeley, in his opening remarks, bore his testimony to the necessity of the formation of a Honey Company, and expressed his opinion that with good management it would undoubtedly succeed.

The Company, by providing a ready and a reliable wholesale market, will no doubt supply a want which has been long felt by all honey producers. It will be ready to purchase pure honey of all qualities at its market value; and as its purchases will always be paid for in cash, this will prove a great boon, especially to small bee-keepers; while the consumers of honey may rely on the character of the Company, and will know where to obtain a pure article.

In some quarters we have heard that exception has been taken to the amount of capital named; but we do not think that this will bear investigation, for if 150 tons—and this may be taken as a fair estimate of the business to be transacted (say) in the first year—were purchased, it would absorb 10,000*l*. The nominal capital of 20,000*l*. will allow of any legitimate extension of business. The amount of capital has been one of the points which has exercised to a great degree the attention of the promoters; and with a view to save expense hereafter, the sum mentioned will permit the Company to be established on a broad basis.

The mode of calling up the capital has been so arranged that persons of small means may have

the opportunity of becoming shareholders, and not be subject to be called upon to meet additional calls on their shares at undesirable intervals.

We understand that a number of shares have already been applied for; but the number of shares (20,000) is large, and it is hoped that bee-keepers and those interested in the promotion of bee-keeping will do their best to render the Company a success by taking shares themselves, and recommending their friends to do so likewise.

The statistics upon which the Company is being formed, and upon which its success is based, have been keenly studied and frequently discussed, and it would appear that there is every reason to anticipate that the Company will be able to pay a substantial dividend.

The Directorate are men of probity, stability, and intelligence, and conversant with commercial undertakings, and their names will, we feel assured, inspire general confidence. We trust that the Company may meet with much success, and that both the honey producers and the honey consumers may derive much benefit from its establishment.

#### NOTICE TO SECRETARIES.

We hope that secretaries of Affiliated Associations will at their approaching annual meetings be careful to elect representatives to attend the Quarterly Conferences with the Committee of the Central Association, and that such representatives will attend the Conferences regularly. It may be well to remind our friends in the country that representatives need not necessarily be residents in the county which they represent. The Rev. A. H. Halley represents the Nottinghamshire Association, though he is a resident in the Metropolis.

The Annual General Meetings of Affiliated County Associations should all be held in the month of January, and the reports and balance-sheets should be in the hands of Mr. Huckle before the General Meeting of the British Bee-keepers' Association in February.

#### BLIGH COMPETITION, 1884-5.

Now that the first of the two seasons over which this Competition extends is fully past, it may be well that we should report progress. The entries were far more numerous than on the former occasion, and the following thirty-three were registered:—

1. Rev. J. A. Kempe, Bohnin, Cornwall, skep.
2. W. A. Bishopp, Isle of Sheppey, frame.
3. Jas. Hedding, Sawston, Cambridge, frame.
4. S. Sprinks, Horsham, Sussex, frame.
5. Fredk. Woodley, Steventon, Berks, frame.
6. C. Brown, Bewdley, frame.
7. Thos. Owen, Corsham, Wilts, frame.
8. Rev. T. B. Garland, Retford, Notts, frame.
9. Douglas Cooper, Normanton, Derby, frame.
10. Douglas Cooper, Normanton, Derby, skep.
11. Lionel Harris, Bradenham, Bucks, frame.
12. R. W. Davis, Braintree, Essex, frame.
13. W. Seabrook, Sutton, frame.
14. W. Baker, Hawkhurst, Sussex, frame.
15. Mrs. N. M. Mutlow, Ledbury, frame.

16. Jas. Arnold, Molesey, Surrey, frame.
17. Rev. F. C. Dillon (withdrawn).
18. Miss M. L. Gayton (withdrawn).
19. Arthur Cooper, Normanton, Derby, frame.
20. Thomas Sells, Uffington, Stamford, frame.
21. Thomas Sells, Uffington, Stamford, skep.
22. Henry Cobbe, Wallingford, Oxon, frame.
23. William Woodley, Newbury, frame.
24. H. E. Roberts, Hitchin, Herts, frame.
25. E. C. Yonens, Dartford, Kent, frame.
26. Arthur Felstead, Kempstone, frame.
27. H. V. Edwards, Mackworth, Derby, skep.
28. Thos. F. Ward, Highgate, frame.
29. William Sells, Uffington, Stamford, Stewarson.
30. Rev. G. Shipton (withdrawn).
31. W. D. Slade, Cheltenham, frame.
32. W. D. Slade, Cheltenham, skeps.
33. Fredk. H. Codd, Stately, Chislehurst, frame.

Of these, however, we regret to say that no fewer than fourteen (Nos. 1, 2, 9, 10, 11, 12, 17, 18, 26, 27, 28, 30, 31, 32) have already withdrawn from the Competition. Of the remaining nineteen, only eleven (Nos. 3, 4, 5, 7, 8, 15, 16, 19, 23, 24, 33) have sent in their two-monthly reports up to the end of October. No reports for October have been received from Nos. 13 and 25; none for August or October from Nos. 20, 21, 22, and 29; none at all from Nos. 6 and 14. Should any of the missing reports have miscarried, or should the Competitors have had any reasonable explanation for the delay, they should at once inform the Chairman of the Sub-committee (Hon. and Rev. H. Bligh, The Vicarage, Hampton Hill, Middlesex), and their names will not be struck out of the Competition.

Competitors are also informed that according to the rules, reports (however short they may be) are required at the end of December and February, as well as in the spring and summer months. To save trouble in future, it will be well that the reports should be sent *as soon as they are due*, direct to Mr. Bligh.

#### CHESHIRE FUND.

J. E. Briscoe .....	£1	1	0
E. Bostock .....	0	10	0
R. Thorpe .....	0	2	6

The Trustees of the Fund have purchased an 'Objective,' and have handed the balance to Mr. Cheshire for a 'Condenser' and any other requisite for his scientific researches.

Correction: In last issue, for J. P. Jackson, II., read F. R. Jackson.

#### READING-BOOK FOR SCHOOLS ON BEE-KEEPING.

We are given to understand that a reading-book for schools on the subject of bees and bee-keeping is being prepared by a member of the Committee of the B. B. K. A.

#### NOTTS BEE-KEEPERS' ASSOCIATION.

We hear that a gentleman has at last been found able and willing to undertake the duties of the office of Hon. Secretary to this Association, vacated a few months ago by the Rev. A. H. Halley, upon his removal from that county.

These is to be a general meeting of the Asso-

ciation at Nottingham, on the 18th inst., for the purpose of the election of Secretary, and other business. Mr. Godfrey, Hon. Secretary of the Lincolnshire B.K.A., is expected to be present, and to deliver an address. We hope that the Association may be able to move with vigour under its new auspices.

#### RECENT INVESTIGATIONS INTO THE STRUCTURE OF THE EGG ORGANS OF THE QUEEN.

By FRANK R. CHESHIRE.

(Continued from page 423.)

##### *Fertilisation of Queen Cells. Analysis of the whole matter.*

Woodcut commonly represent the oviducts as simple membranous tubes, but we must entirely dismiss this notion if we would understand the case. They are tubes, but of fairly large diameter and of great complexity. Muscular fibres and nerve-threads brought into view by proper staining are seen to cross them in every direction. An egg entering them is conducted by peristaltic and muscular contractions much after the manner a woman passes a bodkin through a beam, while all is executed at the rate and in the directions the general movements of the queen and the needs of the hive demand. This is not denying, however, that if a queen be interrupted in her work, her eggs having passed a certain point in their maturation must be dropped, even if no cells are at hand to receive them, but the failure is not in the organization of the insect, but simply the result of accident or our artificial interference.

Although some have stabled\* that two or three spermatozoa have been found within one egg, I, by way of parenthesis, cannot forbear expressing my strong opinion that one spermatozoon and never more passes the narrows when a worker is to be produced, and every observation shows that the protoplasm of the egg immediately the spermatozoon enters flows towards it, closing the aperture.

Some time since I noticed in *Gleanings in Bee Culture*, an American publication, some statements in reference to what was called 'the fertilisation of queen-cells.' Writers communicated that they had opened queen-cells at the upper end soon after sealing had been completed in the natural way by the bees, and that into the opening thus made they had introduced a living drone larva, and then as tidily and neatly as possible had closed all up. They add that in many cases the queens hatched out in due course, but that they were *already* fertilised, and commenced, within a few hours of leaving their cells, laying eggs which produced workers. I cannot compliment any of these correspondents upon the clearness of their explanations. Their extreme disregard of details makes one cautious in receiving evidence which seems utterly at variance with commonly accepted ideas, and at first I admit I was fully inclined to join in the smile of supreme derision in which a friend indulged when I mentioned these artificial fertilisation experiments to him, but my recent microscopic examinations of drone larvae led me to think that at least the whole matter is worthy of systematic and painstaking investigation, and possibly many on this side of the Atlantic may feel disposed to experiment in the coming year. Let one of these American bee-keepers speak for himself. Mr. Price says—'I commenced to doctor or fertilise the cells in forty-five nuclei to test its advantages over the usual way of raising queens, with a view to its commercial value to queen-raisers, both buyers and sellers. Out of forty-five nuclei I raised twenty queens from fertilised cells; the other nuclei either had all the

doctored cells destroyed or the unfertilised cells hatched out first, as the average time for fertilised cells to hatch with me was a little over twelve days—the shortest six days; longest sixteen days. Of the twenty queens from fertilised cells two had imperfect wings, and although large, fine queens, looking like laying queens, they in three or four days came up missing, six laid eggs within twenty-four hours, three laid a few eggs the first day, then quit until the fourth day, when they commenced to lay regularly as other laying queens, three commenced to lay as fertile queens from the first without any interruption.' The others, according to the account given, had no remarkable peculiarities. Beside this method, others insert the drone larva, but crush it, so that the 'juice' carries the virtue. Although the season for drone and queen raising was really over before my attention was drawn to this matter, I determined to sift the question as far as circumstances permitted, when, to my great surprise, upon carefully opening the body of a drone larva which had only very recently been sealed, I found the genital organs already so advanced that spermatozoa abounded, and getting some of the spermatid tubes in their soft, half-formed condition upon a cover-glass, I obtained the spermatozoa, exhibiting under the microscope their well-known characteristic movements.

This opens the way to a possible explanation. All students bee-keepers know that a maturing queen lies in the upper part of the cell, with the posterior part of the body upwards, in contact with the 'royal jelly,' and from this I have for many years held she is constantly drawing nutrition by that absorptive process known as 'snoozing,' and to this fact is mainly due her differentiation from the worker. Admitting this, for the sake of argument, the spermatozoon just referred to from the drone larva would be possibly taken into her body some days after the 'doctoring' of the cell above referred to, by the marvellous vitality of spermatozoa is well known to physiologists. Those of cattle will maintain an independent life for many days, and will not only resist acids but endure freezing without dying; those of the bee, we have abundant evidence, live in the queen during the term of her existence—five years or even more, and so those liberated in the cell by this curious and novel procedure surrounded by drone juices and 'royal jelly' would undoubtedly maintain full energy until the queen was sufficiently developed to receive them. Their insensible power in directing their course, to which I have previously drawn attention, would convey them to the forming spermatheca, and we should have at once a queen fertilised from the birth. This attempt to explain this novelty upon theoretical grounds may suffice us until the spring, but then many experiments will be made, and no doubt curious and most interesting points will come under our observation.

If fertilisation be possibly thus obtainable, it seems very questionable indeed whether the number of spermatozoa received would be at all adequate to keep the queen going for any considerable period; and here again the microscope would at once supply a satisfactory answer, since the examination of the spermatid sac would show how well it had been stored by the essential motile threads.

Let us now endeavour to gather up the main points of, and derive practical conclusions from, this investigation. 1. No squeezing of the queen's abdomen, no roughness short of fatal pinching, can force out the contents of the spermatheca, which ruptures in its sides before its valve

Our writer does not say from what point he starts his calculation.

† The developing queen usually falls from contact with the jelly about thirty-six hours before she commences gnawing out. Her last moult then occurs, and a skin of extreme tenacity is thrown off. With this fall the absorptive process of course ceases.

\* Professor Siebold.

is opened by external pressure. But notwithstanding this, the parts of the body here are so complex and so slightly protected that the queen should never be touched except by the thorax, while she can always be best held by the wings taken near their insertion. Mr. Neighbour a short while since kindly sent me a queen, which continued to lay well, and was for all practical purposes perfect, although the back of her thorax was crushed in. This part of the body may be described as of secondary importance in a queen, as it is principally of service in giving attachment to muscles which move the legs and those which brace up the wings, so that this queen would probably have failed in flight, but her egg-producing powers were unimpaired.

2. Queens do lay eggs in royal cells, and these are fertilised. The evidence here is so strong that no one would have attempted to contravert it except with the idea of saving the pressure theory; but since this itself is now beyond saving, it is only needful to point out that the assertion that queens hate rivals, and therefore would never deposit eggs with the object of producing such, goes for nothing. Might it not be said the queen desires to swarm, and the raising of a successor is a normal requisite in the process? Instinctive acts, seeming to us to indicate feeling, vary according to external conditions—*g.*, the young sparrow, tenderly nurtured, is soon to be driven from the nest and its piteous cries disregarded. The statement given above is a fancy which suits the purpose of the disputant, but which is unworthy of any serious attention, since it is not based on observation. The examination of evidence shows its contrary to be true.

3. Queens mate once, and once only. After absorption of spermatozoa a physical change occurs, the closure of the large avenue to the spermatheca, which would render subsequent mating inoperative. Some authorities have described this to be the drying up of some part of the organ, but this is certainly an error. The bursa to receive the drone organs remains as large and decided in old queens as in those a few days old. This bursa extends laterally, and the horns of the drone are here firmly fixed and torn off.

4. The spermatozoa are so distributed in the duct through which they pass by the addition of glandular secretion that but few in comparison with the number used are wasted. A queen of fine quality might lay 1,500,000 eggs, a sufficient quantity to fill a half-pint measure; even were these eggs put into the smallest possible space by close and systematic packing, these would require nearly that number of independent fertilisations. A problem of wondrous complexity is presented, but the solution is as beautiful as it is surprising. The five muscles (one to close the gland, another to close the spermathecal duct, another to open the spermathecal aperture, and two more to shut the same), together with the two glands, and the three ducts, lie in a space  $\frac{1}{16}$  of an inch in diameter, while the tendons terminating the two shutting muscles are only  $\frac{1}{160}$  of an inch across, or about  $\frac{1}{4}$  of the thickness of an ordinary hair, while within the same small space are also included all the necessary and very numerous nerve fibrils.\*

5. A mated queen is a perfect combination of two sexes. She carries the glands physiology commonly ascribes to the male. The spermatozoa she holds in

store are continually nourished, as is evidenced by the abundance of air-vessels (tracheæ) which surround the spermatheca. Oxidisation means vital energy and nutrition also, unless exhaustion follow.

6. Drone-eggs are so conducted as to avoid all contact with the fertilising pouch, and so drones are produced parthenogenetically.

I leave now this subject until the spring, hoping then to re-sume it in another connexion, suggested to me by some bees kindly sent by Mr. Wm. Thomson, of Blantyre. I trust that the work this matter has exacted will not be without some influence upon practical apiculture, and that it will supply some emulating reflections to those not less fond of natural history than myself.

## ASSOCIATIONS.

### HONEY SHOW OF THE ESSEX BEE-KEEPERS' ASSOCIATION.

This show was held at the Chelmsford Corn Exchange on November 19 in connexion with the Chrysanthemum Show of the Chelmsford Horticultural Society. The Rev. George Raynor, Rector of Hazeleigh, was the judge of the honey and wax. The quantity of honey staged exceeded 240 lbs. in weight, and most of the exhibits were of fine quality. Besides those who took prizes, some fine sections were exhibited by Mr. G. H. Aubrey, of Springfield Villa, and Mrs. Tufnell Tyrell, of Borcham House. Extracted honey was also exhibited by Mrs. Fillbrook, Gallywood Common, Mr. C. R. Finch, Great Baddow, and Thos. Salmon, Great Leighs. Some good beeswax was exhibited, also some fine sections were sent by Mr. E. Durrant, of High Street, Chelmsford, not for competition. The glass super of Mr. Cobb and the extracted of W. Debnam were especially admired by the visitors.

The following are the names of the prize-winners:—

Honey.—Six 2lb. or 12lb. section of honey comb; 1, Miss Owen, Bradwell Rectory; 2, W. Debnam, Primrose Hill, Chelmsford; 3, C. R. Finch, Great Baddow. Super of honey; 1, Mrs. Cobb, Great Waltham; 2, W. Debnam. 12lb. of extracted honey; 1, W. Debnam; 2, Rev. F. M. Sparks, Billerica; 3, G. Gray, Rocking. Finest sample of beeswax; 1, W. Debnam; 1, G. H. Aubrey, Springfield Villa; 3, Geo. Gray.

W. DEBNAM, *Assistant Secretary and Expert, E. B. A.*

### NOTTS BEE-KEEPERS' ASSOCIATION.

A meeting was held in the last week in November at Radcliffe-on-Trent, with a view to resuscitate the Notts B. K. A. Those who were present Mr. E. Price, Mr. E. Fernyough, Mr. R. H. Rushton, Mr. W. Rose, Mr. R. G. Turner, Mr. W. H. Pumphrey, Mr. Richard Rose, Mr. H. D. E. Price, Mr. S. Rose, and others. Mr. R. R. Godfrey, of Grantham (hon. sec. Lincolnshire Bee-keepers' Association), was also present. Mr. E. Fernyough was voted to the chair, and in his opening remarks said the object of the meeting was one of great moment, and he hoped that all present would advance their opinions, so that they might arrive at some satisfactory and favourable conclusion. He hoped the result of the meeting would be the determination to support a good county Association.

Mr. R. R. Godfrey spoke strongly against the formation of a small rival Association, and thought the best course to pursue would be for a deputation to wait upon the gentleman who had kindly consented to act as hon. sec. to the Notts Association until some one was duly appointed, and ask him to arrange a meeting of those bee-

\* Surprising as this minuteness seems, it is as nothing in comparison with what might be cited. This valve is about the size of the whole body of the Anaphes, the smallest known member of the order of insects to which the bee belongs. This 'little wonder' does not weigh more than the  $\frac{1}{160}$  of a grain. It has four wings, six legs, with their full complement of joints. Two antennæ with thirteen joints each, multiple eyes, and so on and so forth. It performs all vital acts, lays eggs, carrying all essential parts which in turn produce grubs utterly invisible to unaided vision.

keepers who had been elected as the committee, and to learn what was the exact position of affairs. He further counselled that the deputation should go prepared to offer for election one who would undertake the office of hon. sec., and concluded by proposing that the chairman of the present meeting (Mr. E. Ferny) should be asked to head the deputation, and offer himself for the position of hon. sec. This proposal was seconded by Mr. Rose, and agreed to unanimously. The latter gentleman together with Mr. Price, offered to undertake the duties of district sec., and promised to interest themselves in securing district hon. secs. in other parts of the county.—*Nottingham Daily Guardian, November 28.*

[We beg to acknowledge the receipt of a report of the above meeting from Mr. Thomas Rose, Radcliffe-on-Trent.]

#### NORTH-EAST OF IRELAND BEE-KEEPERS' ASSOCIATION.

On Friday evening, 5th inst., an essay was read at 41 Waring Street, Belfast, in connection with the above Association, by Mr. Wm. Ditty of Newry-wards, on "The General Management of the Apiary." The Rev. H. W. Lett, M.A., occupied the chair. Mr. Ditty first described the site of the apiary, stating that it should be located in a spot sheltered as far as possible from the strong and piercing winds of winter, and open towards the south and south-east, and that, if space was no object, hives should be placed from twelve to eighteen feet apart every way; that the ground in front of the hives should be free from grass and weeds of all descriptions, and covered with gravel, sawdust, or bog-mould, as may be most convenient. The hive was next described, and then the bees. The essayist stated that after due consideration he had come to the conclusion that Ligurian hybrids are the best sort of bees for the production of honey either in the comb or extracted. The next subject he brought under consideration was the spring treatment of bees, recommending that, if necessary, the bees should be crowded on to five, four, or even three frames, and that an examination should be made about once a-week, and a memorandum kept of the date of inspection, the number of frames covered with bees, how the brooding is progressing, and the quantity of food in the hive. In order to assist in bearing the statistics in mind, Mr. Ditty stated that he used an index register.

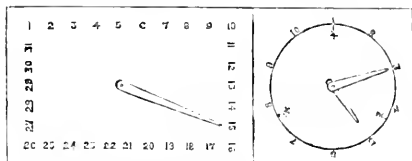

The square-shaped index register presents the days of the month, and as the first examination was made on the (early) 15th March, time the index pin to 15 on the square figure, representing the days of the month. The round figure is numbered from 1 to 10, which may represent at the ten brood combs, or the frames for extracting, or may be used for other purposes as may be thought of, the figures on the inside of the circle may represent the brood combs or supers quart, half, or three-quarters filled. To make these "Bee-keeper's Forget-me-nots" all that is required is to get a piece of white card-board and put the figures on as shown; the hands can be cut out of a piece of tin with a pair of scissors. The index may then be tacked on the inside of the roof.

Mr. Ditty then went fully into the subject of rearing queens, making artificial swarms, &c., and concluded by remarking that life to the bees seemed one long day of

continual joy, reminding us as they gather homewards of the goodness and bounty of an All-wise and Divine Providence in teaching His creatures to lay by a store for their earthly wants. Some discussion followed, and a vote of thanks brought the meeting to a close.

#### IRISH BEE-KEEPERS' ASSOCIATION.

The Committee met on Tuesday, 2nd December, in the rooms of the Society for the Prevention of Cruelty to Animals, 369 Westmoreland Street, Dublin. It was resolved to hold the spring show of hives and bees in connexion with the Royal Dublin Society's Cattle Show at Balls Bridge, on the 7th, 8th, 9th, 10th April next. The annual general meeting to be held as usual on Thursday, the 9th April. It was decided to advertise the names of establishments who sell honey obtained from members of the Association. Letters and other communications having been considered, cheques were passed and drawn, and the Committee adjourned until January next.

In the report of the Annual Honey Show, Class 78, for the best bar-frame hive for summer and winter use, price not to exceed 2/ 2s., was accidentally omitted. The first prize and silver medal was awarded to Mr. S. J. Baldwin, The Apiary, Bromley, Kent; second prize, bronze medal, Mr. W. Lonsdale, 1 Wympe Terrace, Lurgan; A. H. C. Messrs. Edmondson, Bros., 10 Dame Street, Dublin; H. C. Mr. W. Lonsdale, 1 Wympe Terrace, Lurgan. The judges reported that they considered Mr. Baldwin's hive of especial merit, and a most perfect hive in every respect. CHARLES FRENCH KNIGHT, M.D., Hon. Sec., 82 Harcourt Street, Dublin.

#### CHESHIRE COUNTY BEE-KEEPERS' ASSOCIATION.

The above Association has during the past season held four principal shows in different parts of the county, and assisted at two others with the manipulating tent. The exhibition held at Cheddle on 15th and 16th August last, by kind permission of, and in connexion with, the Cheddle Horticultural Society, proved a success in every way. The driving competitions in the new tent of the Association excited great interest on both days, being supplemented by the able and interesting remarks of Mr. Carr, of Newton Heath, and Mr. Manchester, who also officiated as judge of exhibits, and whose awards it is pleasing to note, gave entire satisfaction. A case of Huntley and Palmer's biscuits and honey drops, kindly lent by Mr. Carr, also added to the interest of the exhibition. The observatory hives, stocked with bees and queen, were objects of general attention from the numerous visitors. The thanks of the committee are due to Mr. E. D. Stone, the Hon. Secretary of the Cheddle Horticultural Society, for his genial manner in meeting and offering facilities to the Association when the proposal of holding a show was first made, and for assistance in carrying it out. The prizes offered and the awards were as follows (in the eighteen classes), viz.:

For best stock of bees, Mr. Franks, Bowdon. For best collection of hives and bee furniture—No entry. For best observatory hive, stocked—1, Mr. Cotterill, Malvern House, Bowdon. For best hive of honey in straw skep, without bees—1, Mr. Cotterill; 2, Mr. Franks, Bowdon. For best exhibition of honey from one apiary—1, Mr. Cotterill. For best super of honey, not being a sectional super, &c.—1, Mr. Hewitt, High Leigh, Knutsford; 2, Mr. G. Stocks, Winsford. For best 1-lb. Sections—1, Mr. G. Stocks; 2, Mr. Cotterill. For best 2-lb. Sections—No entry. For best exhibition of 12 to 30 lbs. of run or extracted honey, in 1-lb. glass jars—1, Mr. Cotterill; 2, Mr. Stocks. For best exhibition of run or extracted honey, in 2-lb. glass jars—1, Mr. Cotterill; 2, Mr. Stocks. For best glass super of honey in comb—1, Mr. Hewitt; 2, Mr. Bush, Ashley Heath. For best 2-lb. of

bees-wax, in 1-oz. moulds, to have been obtained from exhibitor's own bees—1, Mr. Cotterill. Driving competition—1, Mr. Cotterill; 2, Mr. Franks. In cottagers' class for best stock of bees—No entry. For best glass super of honey—1, Mr. Hewitt; 2, Mr. Franks. For best straw super of honey—1, Mr. Nicholson, Vicarage Lane, Bowdon. For best six 1-lb. glass jars of honey, run or extracted—1, Mr. Stocks; 2, Mr. Hewitt. Driving competition—1, Mr. Franks; 2, Mr. Hewitt.

The exhibition held at Davenham in connexion with the Horticultural Society was marred by a thorough wet day, the rain never ceasing falling. Prizes to the amount of 15*l.* were offered and were awarded as follows:—

For best stock of bees—1, Mr. Cookson, Sandbach. For best observatory hive—1, Mr. Cotterill, Bowdon. Five of honey in straw without bees—1, Mr. Cotterill; 2, Mr. Franks, Bowdon. For best exhibit from one apiary—1, Mr. Stocks, Winstford. For best super, in wood, glass or straw—1, Mr. Stocks; 2, Mr. Hewitt, High Leigh. For best 1-lb. Sections—1, Mr. Stocks; 2, Mr. Cookson. For best run honey, in 1-lb. glass jars—1, Mr. Stocks; 2, Mr. Cotterill. For best glass super—1, Mr. Hewitt. For best exhibition of bees-wax—1, Mr. Cotterill; 2, Mr. Stocks. Driving competition—1, Mr. Stocks; 2, Mr. Cotterill.

COTTAGERS' CLASSES.—For best stock of bees—1, Mr. Franks, Bowdon. For best glass super. 2, Mr. Franks. For best hive of honey—2, Mr. Franks. For best 1-lb. glass jar of honey—1, Mr. Stocks; 2, Mr. Hewitt. Driving competition—1, Mr. Franks.

#### BRITISH BEE-KEEPERS' ASSOCIATION.

The Rev. J. Lingen Seager, the Honorary Secretary of the Hertfordshire Association, has promised to read a paper on 'The Judging of Honey,' at the next Quarterly Conversazione.

## Correspondence.

### QUEEN INTRODUCTION.

Since Mr. Simmins, in the opening sentences of his last letter on this subject, has seen fit to accuse me of something very like falsehood, and has introduced baseless inferences and insinuations, I must henceforth decline to discuss the matter further with him. With your permission, sir, I will make to you a few short statements on points which appear to require elucidation.

First, I am accused of 'not following Mr. Simmins,' by which I presume that he means I have not strictly followed his instructions when making the experiments, the disastrous results of which I reported in your columns. He is mistaken. The bees were slightly smoked, the queens quietly removed, and the alien queens as quietly introduced, with their bees and frames of brood, and the hives were immediately and carefully closed, without any further disturbance. Of the queen encasements I was quickly made aware by the disturbed state of the bees at the entrances—wildly rushing in and out of their hives, over the alighting-boards, and up and down the front of the hive, as if in search of something which they were unable to find—the sure signs, to any one who has ever witnessed a queen-encasement, that such had actually taken place. Then, and not till then, did I again open the hive, only to find the poor queens encased. They of course were immediately released and saved from death, but in two instances I was too late, and the queens were sacrificed. There was no 'fussing,'—whatever that may mean,—nor interference of any kind with the hives or colonies. Truly 'the job was done,' as Mr. S. observes, but not in the manner I wished.

Again, Mr. S. states in his pamphlet that by his method 'fertile workers, no matter how bad the case may be, even if they have queen-cells, will subside immediately on the insertion of an unprotected queen on her own comb of brood.' Not very long ago I had a

queenless colony which became possessed of fertile workers, and having a couple of fertile black queens to spare, I determined to try this plan again. On opening the hive I found two queen-cells, doubtless containing drone-brood, but they were left intact. On a comb of her own brood, with her own bees around her, a queen was quietly introduced into the centre of the hive. The hive was 'closed at once.' In ten minutes the queen was cast out dead. I allowed the hive to remain *in statu quo* for three days, when I again introduced the remaining queen in precisely the same manner, except that the queen-cells this time were removed. In about half-an-hour this queen also was cast out dead.

I then resorted to the old method of removing the frames and bees to some distance from the stand, shaking off the bees and allowing them to return to the hive. The combs were also returned, and towards evening I removed a valued queen from another colony, and caged her on a comb near the centre of the hive. On the following morning, finding the bees kindly disposed, I released her, and she is still a prolific queen at the head of the same colony.

Your predecessor, sir, Mr. Abbott, used constantly to remind us of that trite maxim, 'Bees do nothing invariably;' but Mr. Simmins appears to have reversed it, and holds that the opposite is the truth, since, on the title-page of his pamphlet, he states that 'his process ensures success in every instance,' and his pages are interlarded with utterances of similar import, as, for instance, 'absolutely without risk' (in capitals)—'a failure is an impossibility even to the merest novice.'

Mr. Simmins triumphantly announces a large majority in his favour. This, again, I dispute, and assert that the weight of testimony is on the other side. The value of testimony in practical bee-culture depends upon its *quality*, and by no means upon its *quantity*: e.g. the testimony of a Cheshire or a Cowan on queen-introduction, or *spontaneous foul-brood*, is of more value than that of a thousand infantile Smiths, or of those who only publish partial results of their trials or experiments. I have in my possession sufficient private testimony to convince any reasonable person; but my friends have no mind to be subjected to the same amenities, with which I have been favoured, by speaking out in public. And yet, sir, forgive me if I venture to remind you, and your classical friends and readers, of those beautiful lines which I am sure you have not forgotten:—

'Non quisquam fructur veris odibus,  
Hyblæos latebris nec spoliat favos,  
Si frontem caveat, si timent rubos,  
Ornat spina rosas, mella tegunt apes.'

Perhaps, however, you and they may justly retort,

'Sic vos non vobis mellificatis apes.'

the truth of which I fully admit.

And here let me refer to the statement of Mr. T. Isaac, of Maldon, in your issue of November 15th, page 405, to the effect that he had successfully introduced an Italian queen by Mr. Simmins' method. Mr. Isaac mentioned this fact to me, but he also stated, that on a second attempt to introduce another queen, by the same process, she was cast out dead within the hour. These, I understood, were the only attempts at queen-introduction which he had made by this process. Mr. Isaac, in fairness, should have stated in your columns his failure as well as success. Perhaps the estimation in which he holds the process may be better arrived at by his letter to me of the 11th October last, which now lies open before me, and was written subsequently to his queen introduction, in which he states that 'having a son in Australia, to whom he wishes to send two of my pamphlets on Queen Introduction, he should feel obliged if I would send him two copies, for he says, "I thought I could not do better than send him your pamphlet."' If Mr. Isaac is so much in



honey they store. I have forwarded two photographs of the exterior and interior of the house. The door faces south.—G. C. E.

[The photographs have been received, with thanks.—Ed.]

#### THE AWARDS AT THE HEALTHIERIES.— SILVER MEDAL TO ABBOTT BROTHERS.

I could not help noticing in your report on pp. 389-90 how very carefully you avoided all expression of opinion on the merits or demerits of the exhibits for which awards had been made, and it occurred to me that you must have had in your mind some sort of mis-giving as to the justice of the judgment that left our exhibit 'out in the cold.' Until after the close of the show I was not aware that any awards would be made, and, when ordered to do so, sent our men to fetch our exhibit away, but to my surprise they were sent back again and our goods retained, to be re-judged; some of the officials at the Healthieries having discovered that a glaring injustice had been done to us in passing over our exhibit altogether, while others had received awards of greater or less importance. I offer no suggestion as to the relative merits of the various exhibits, but when I heard that awards had been made, and that my name had no mention, I felt that there was a screw loose somewhere, and, having made inquiry as to who were the judges, was informed that a gentleman had gone round accompanied by Mr. Cheshire. That our exhibit was not unobserved I am confident, for the gentleman called Mr. Cheshire's attention to the number of silver and bronze medals displayed in our show-case, but beyond this I prefer not to enlarge on the conversation that ensued.

I must, however, very respectfully call the attention of the British Bee-keepers' Association Committee to the grave injustice that may possibly arise from what, to use the mildest term, I will call THE CARELESSNESS of the special experts appointed (I naturally suppose by the said Committee) to accompany judges (?) who really know very little, if anything, of the subject they are employed upon. The present editor and proprietor of the *B. B. Journal* will remember a flagrant case that occurred at a Surrey Exhibition, after which it was distinctly undertaken by the said editor and proprietor that the offending party should not be permitted another chance of airing the personal ill-feeling so palpably shown on that particular occasion. I put in this reminder for what it may be worth, and with every confidence that its value will be appreciated. I ask of Mr. Cheshire that he will be as fair and above-board as was Mr. Otto Helmer in respect of the exhibits at the Reading show this year. Mr. Helmer went round with the judges there, and, as he himself admits, through a little carelessness, caused us the loss of the first prize for wax-foundation. You were good enough to publish Mr. Helmer's explanation of how the mistake occurred, and that, and his private letter with certificate to us, removed all feeling in the matter, though they did not regain us the prize. In the present case, however, there is something unexplained, and I trust Mr. Cheshire will be frank enough to give a reason why our exhibit was not considered worthy of notice.

I beg to hand you the certificate of award, and, thanking you in advance for the favour of insertion, remain your obliged servant, C. N. ABBOTT, (trading as Abbott Brothers), *Southall, Dec. 2, 1884.*

JURY DEPARTMENT, SOUTH KENSINGTON, S.W.

*Norwood*: 27, 1884.

Sir,—I am instructed to inform you that the Jury Commission have decided to award you a Silver Medal in Class 1.—I have the honour to be, Sir,

Your obedient servant,

THOMAS WINTNER,

Messrs. Abbott Brothers.

Jury Superintendent.

#### FOUL BROOD.

The bee-keeping fraternity are anxiously awaiting the further investigations in the physiology of the bee, and the nature and cause of foul brood and other bee diseases by Mr. Cheshire, and all may now look upon him as the chief pioneer in the various scientific investigations connected with bees and bee-keeping.

Will Mr. Cheshire kindly give his opinion on the discovery by Mr. Langstroth in 1852, see page 125 of his book?—R. THORPE, *Langrick.*

#### FOUL BROOD: ITS CURE BY FASTING, WITHOUT THE USE OF DRUGS OR CHEMICALS.

There has been so much said of late on this subject that it would seem to be pretty well worn out; but there are yet many apiaries suffering from the malady, where a simple and effective treatment would be gladly tried if known. I have experimented considerably, and found that the disease can be cured without any difficulty, without any medicine, and without any possibility of its ever returning.

Perhaps I may be allowed to describe the disease as I have found it in Canada. In speaking of foul brood I would first distinguish it from all other diseases, such as chilled brood, over-heated or scalded brood, neglected brood, starved brood, dead brood caused by shipping bees, and another kind of dead brood which resembles foul brood in some respects, and is doubtless what some call a mild type of foul brood. It would make this article too long to describe minutely the appearance of the various kinds of dead brood above referred to, and the various causes of its appearance. I also do not wish to interfere with any other person's system of curing foul brood, but simply to give my own, which has proved successful with myself and scores of others, in the hope that those who have tried various remedies unsuccessfully may be encouraged to try once more with no further expense, and, with but little trouble, rid their apiaries of this foul disease. I do not believe with some, that there is only one method of cure (and that their own). I know by experience that it can be cured in various ways, and I intend to continue my experiments with the aim of still further simplifying, if possible, the method of cure.

Some imagine that foul brood may be discovered by the foul smell arising from the diseased colonies. This is true as far as it goes; but if one waits until then, there is a probability that very many, if not all the colonies in his apiary, have become diseased. Before such a condition had resulted, the disease would have been running for a long time in some one or two colonies, from which, especially in spring or fall, when robbing is carried on more or less, the surrounding hives would surely be contaminated and become centres of infection. A single drop of honey taken from a diseased hive, if fed to the larvae of a healthy hive, is sufficient to start the work of what, unarrested, is inevitable destruction. When the disease becomes very bad, much of the brood dies before it is capped over; and never is capped, after it once dies. I have frequently seen colonies that had become so diseased that a very large portion of the brood had died just before it was capped, and some of the larvae before they had got their full growth.

In examining the larva just before and after it dies, I find that a dark spot first appears about its centre, and increases in size very rapidly. Shortly after its appearance, short threadlike veins extend from this centre towards both extremities of the larva, and appear to plant two new spots, from which more veins soon radiate. The veins and spots gradually enlarge until the entire larva is uniformly affected. The skin of the larva also commences to wrinkle and shrivel up on the top side, the larva flattens down, and gradually recedes to the back of the cell, and finally becomes the brown, putrid mass



which distinguishes foul brood so markedly from all the above-mentioned maladies.

This brown rosy matter has a sticky and tenacious—almost elastic—consistency; and if a pin-head be inserted in it and drawn slowly out it will stretch like india-rubber, and jerk back into the cell again. The bees make efforts to remove it, but after a few trials give up in disgust, and philosophically endure what even they find too inexcusably obdurate to cure. Allowed to remain, this viscid substance in time dries up at the bottom of the cell, and would not be noticed except by a close observer.

A diseased larva that is capped over is indicated by a sinking of its capping compared with the taller appearance on the capping of healthy larva. A small puncture is also made by the bees in the capping in size from a pin-point to pin-head. This seems to satisfy them that there is nothing to expect, and the cell is left to itself. If the apiarist opens such cells carefully, and finds the contents as above, he may be sure he has foul brood; but if the larva retains its shape and size, and the skin seems perfect, even though somewhat shrivelled, that is *not* foul brood. These punctures are sometimes made in merely dead-brood capping, their non-emergence at the proper time being doubtless noticed by the bees and thus investigated. Whenever foul brood exists in a colony during the brooding season, the brown rosy matter in the cells may be found.

I could describe several methods of cure, but the following I think will be ample; and as it is very simple and easily performed, it comes within the reach of every body. If the bees have any brood, I do not destroy that brood. I remove all the bees that can be spared from the hive, leaving only sufficient to take care of the brood while it is hatching, taking the queen with the bees. I endeavour to have them all filled with honey before removing. They are then shaken into a box with a wire screen lid, and placed in a box in a dark and cool cellar. The box should be turned down on its side; the bees will cluster on the other side, which will then be uppermost, and the wire screen, forming a side for the time being, will allow of a free ventilation. They should be left thus from three to six days, according to the temperature and condition of the bees, which may be determined by watching; and when a few bees fall down, and begin to crawl in a weak, stupid manner, and those still clustering appear to have shrunk, they may then be removed, placed in a hive, and supplied with comb or foundation, the same as a swarm. A little honey or syrup should be given them, when they will soon be out foraging again for themselves. I have not been able to see any difference between swarms so fasted until the foul honey in the abdomen has been consumed and an ordinary swarm of similar size. Both seem to go to work with the determination that characterises their race.

Some still say this fasting plan is a failure; but where that has been said it cannot have been properly tried. As soon as the brood, which was left in the foul-brood hive with bees, as directed, is hatched out, they should be treated like the others, the combs rendered into wax, and the hive and frames boiled for a few minutes in hot water. The wax in the form of foundation may be inserted in the frames, and be ready in the purified hive to receive with perfect safety the former inmates as soon as their purification is complete. The honey in the foul-brood comb, if extracted and boiled for ten minutes, can be fed to bees without any fear of bad results. Only *boiling* will kill the germs of the disease. I have subjected foul-brood combs to a temperature of 35 below zero, and allowed them to freeze all winter, then placed one of them in a healthy nucleus; and as soon as it was filled with brood and commenced to hatch, I have found at first examination a very large number of larvae affected with foul brood. Frost will, therefore, not kill the disease.

I search out every case of foul brood in this part of Canada, and have never failed to effect a cure at the first attempt. In fact, there are a great many in Canada now who no longer dread foul brood as they used to, knowing they can cure any colony with one or two hours' labour.

We have had some good and valuable hints on foul brood in the journals, and some sheer nonsense. Fine-spun, scientific theories are sometimes good, but solid facts from extensive practical experience are what suit me best. — D. A. JONES, *Breston, Canada* (*American Glanings in Bee Culture*.)

#### PRICE OF HONEY.

J. O. Coussmaker, on p. 308, asks, Is section honey only worth *8d.* per lb. ? and states that he saw Scotch honey for sale in London not two years ago at *3s.* per lb. quite likely, and from a report of 'A Lanarkshire Bee-keeper' in a recent issue of the *Journal of Horticulture*, I see that Glasgow whole-sale houses are giving *2s.* per lb. for Stewarton heather honey sugars (wholesale), so it is quite possible when it reaches London, *3s.* will again be the price of Scotch honey-comb.

Bee-keepers should remember that there is a vast difference between heathen-comb honey and other kinds; this honey can may be hid on a bread-platter and cut up into thin slices, without any of the honey draining away, as clover honey will do; this fact, and its superior appearance, make it *par excellence* the honey of all honeys for use on the table in the comb; and as the supply is limited, owing to the fact that to obtain it bees have to be moved to the moors and back, with the expense and risk attendant thereon, while amongst the better classes the demand is unlimited; the natural order of things just fixes the price according to the demand, like clover sections have fallen from *2s. 6d.* to *8d.*

There is now, I see, a lot of people setting themselves up as honey merchants to relieve people of their hard-earned harvests; when such people are going about offering *8d.* to *9d.* per lb. for sections, it would be as well to remind bee-keepers that foreign honey in large casks, which varies from fine strained (no extracted), to a mixture of honey, crushed brood, pollen and dead bees, is at present fetching *2 1/2d.* to *6 1/2d.* per lb. in the London market, from the brokers who supply the wholesale houses, who in turn supply the shopkeepers. The great drawback to selling to shopkeepers is, that they will not give the prices they pay to their wholesale houses, from whom they get perhaps six months' credit; a bee-keeper to them is 'out of the trade,' and thus fair game to pluck. I am rather anxious to know, how the 'Honey Company' will get along unless they supply wholesale houses only, if so, they will require a very clever seller to effect business and always get the full market price for the honey.

I do not see why bee-keepers cannot retail their own honey; a card stuck in the window 'Honey for Sale' for passers-by to see, will do wonders, as everyone has a desire to buy at first hand, not so much for cheapness, as to be convinced regarding purity and quality; if your house is not seen by passers-by, then fix it where it can be seen, adding such words as, 'Up this Road,' as may be the case; if this cannot be done, you might arrange with some one in your nearest town to sell it for you, in the same way. Now, before any honey is sent away to other markets, just sell what you can at home, and then you can ship the balance which, from my experience, will be nothing. If the quality is good and the price not too high, you will be surprised at the number of customers you will get, as one will tell another where to get some splendid honey at a low price—and depend on it, they will give it more praise than you would; as a matter of fact, I don't know a single bee-keeper who adopts this plan that ever has any honey to sell at

Christmas, mine is generally all gone by October; they begin selling as soon as they get any in spring at 1s. per lb. for extracted in the buyer's own pots; which will compare favourably with selling sections at 8d. and 9d. in the bulk.

The advice of Mr. Lyon for 'bee-keepers to use a little commercial common-sense,' is very good if properly applied, that is, *first try your nearest market before sending to a distant one*; if everyone will send their honey to Reading or London, they must expect to force down the market in these places, while they and their neighbours are no better off for it.

Mr. Coussmaker thinks it will pay better to sell swarms at 12. each than to raise sections at 8d.; but who will be so foolish as to buy swarms at all, if raising honey will not pay; if it comes to this, not only will bees be valueless, but all kinds of hives and bee-gear also, as they only represent plant or means of producing honey and wax—the only two articles of ultimate use.—JOHN HEWITT, *Sheffield*.

#### QUERY ON THE PRODUCTION OF EXTRACTED HONEY.

Mr. W. Ditty, jun., writing on this subject in *B. B. J.* (page 50), in February 1st, says: 'I use a long hive containing twenty frames on the Combination or Longitudinal principle, having double sides and front, with one-inch space between the sides, packed with chaff, and the back of the hive is single.' . . . 'The best hive for the advancing bee-keeper.' . . . 'My bees have filled twenty frame-hives every season, nay, more, I have been obliged to put a crate of supers to keep them from swarming. I have tried the doubling principle, and put this hive far before any double-story hive for extracting honey. It is unnecessary here to state my objections to the double-story system. The great secret of successful honey-getting is to have strong hives ready to take advantage of a flow of honey when the weather answers.'

I should be pleased to know why Mr. Ditty disapproves of the doubling principle. As an amateur, I am anxious to know, so that my new hives may be made accordingly. I have tried one hive on each principle during the summer. A ten-framed hive I doubled from another hive. I procured from the former 105 lbs. of extracted honey; but the bees swept back on foundation into the hive from which the brood was taken, nearly all left and went into another hive, and after a short time swarmed out again. I put them back in the original hive, but they did very little during the season, only giving 8 lbs. of extracted honey. The bees in the longitudinal hive filled twenty frames, but I could not keep the queen before the excluder. This hive gave me 63 lbs. of extracted honey. Both of these I consider partial failures. I procured 600 lbs. of honey from ten colonies; three of these colonies swarmed two or three times, in consequence of which they produced but little honey.—MID CORNWALL.

#### JUDGING

'An Occasional Judge' deems it prudent to defend judging, and explains the great difficulty judges labour under while endeavouring to give satisfaction; my wish is to have those difficulties removed as far as possible. He says I am vexed, I will only say I have a pure aim to set judging on a clear and sound basis. I am not alone in this, others agree with me that there is the greatest possible necessity for some standard of excellence to be adopted, both to guide the exhibitor in competing and the judge in judging. And what I ask is that the judges of the B. B. K. A. should decide the various standard points of merit, and let the bee-keeping world know that all exhibits will be tried by this standard.

The judges are not infallible, they do make great

mistakes, and even after a standard is chosen there will errors, but they will be minimised. I have very little faith in the judgment of some of them, their judgment varies at different shows, even upon the same exhibits, as can be proved. I think a judge makes a great mistake in deciding in flavour only, particularly as the different judges have such various tastes. My opinion is that the judges' tastes should reconcile itself to public opinion. That which finds preference in the market, so far as taste is concerned, should receive the merit. Then should follow the other standard points upon which his decision is based, colour, consistency, clearness, &c. For each standard point I would allow so many marks, and where the points failed in each exhibit I would erase them according as deserved.

I consider it unfair that the public who come round the shows to look at the class wishing for light to guide them in purchasing, should see such a diversity of judgment, so conflicting and misleading. I could furnish the clearest testimony of what I assert, but it would only lengthen the correspondence.

I may say there are many producers of honey who are quite as competent judges, knowing as much and more in some instances of the fitness of exhibits, and I may say they know better than to send a section with only one side to the show as I infer from 'An Occasional Judge's' letter. He, however, does prove one thing plainly, that is, that connoisseurs vary, one preferring heather, and another pins the ticket of merit on apple-blossom, and this illustrates the necessity of a reliable, unvaried platform; it is of more consequence than a connoisseur's whimsical fancy.

I agree with him on the merit of clover honey, its purity of taste is excellent, its rich golden colour is attractive and tempting, I find it irresistible and make special effort to get it.

There are a few pens with much more energy and culture than mine that are interested in promoting a standard of merit for honey, and I do trust it will be urged to a successful issue by them.—SCATIONMASTER.

#### ROYAL AGRICULTURAL SOCIETY FOR 1885.

I see from the report of the Council of the Royal Agricultural Society that the county meeting for 1885 will be held in the district which includes North Wales, Cheshire, and Lancashire. Would not the Committee of the British Bee-keepers' Association be inclined to adopt this arrangement, and to allow members of affiliated Associations in North Wales to enter at half-fees as well as those in the counties of Cheshire and Lancashire? North Wales would, I suppose, include the counties of Anglesea, Carnarvon, Denbigh, Flint, Monmouth, and Montgomery. I do not know how many of these counties have affiliated Associations.—ROYALIST.

#### HUMBLE BEES FOR NEW ZEALAND.

I have received the enclosed letter respecting the above subject. Perhaps it may interest some of your readers. If any one wishes for further information, or to make arrangements for sending out bees, I advise him to communicate with Mr. R. Bernard Williams, New Zealand Shipping Company, 135 Leadenhall Street, E.C., not sooner than the end of December, or the beginning of January next, as he will not be in England before that time. Respecting the terms of granting the reward, I have not been able to obtain further information, except, as Mr. Platman mentions, that the Agent-General for New Zealand has referred the matter to the Government in New Zealand.

Mr. Hewitt thinks that Mr. Neighbour and myself are 'at sea' respecting the natural history of these bees. Well, perhaps we are; I, for one, shall be very glad

if the result proves Mr. Hewitt to be correct, and, shortly to learn, that he, with his 'ship, literally freighted with fertile dormant queens, is not only 'at sea,' but safely handed in that 'El Dorado' of the honey-bee—New Zealand,—having obtained the just reward of his knowledge, energy, perseverance, and skill.—GEORGE RAYNOR.

To the Rev. G. Raynor.

'DEAR SIR.—It occurs to me (though I am very ignorant of such matters) that there are two ways in which humble bees might be taken to New Zealand.

1st. Supposing a hive were placed in a glass cage with feeding-troughs of honey covered with perforated zinc to prevent the bees drowning, would it not be possible by regulating the temperature to take them out alive in this way.

2nd. If I took any thus, I should keep them in my own cabin, and when the weather became too cold, should remove them to a warmer atmosphere, which could be easily found in a steamship. Of course, in order to carry this out it would be necessary for me to know the temperature at which bees begin to hibernate, as I imagine hibernation does not necessarily begin at a certain time every year, but is regulated by the change of temperature. You must please bear in mind that I am profoundly ignorant in this matter, and that I am seeking advice and not for one moment pretending to offer it.

3rd. If bees were given me in their winter state, I should place them in our cooling chamber where there is a steady temperature of, say, 40 degrees Fahn. This would keep them, I fancy, all right till our arrival in New Zealand; but there is this to be considered, that by leaving England in January, we should arrive in New Zealand in March, which in that country is the end of autumn, so that the poor brutes would have but a short life before again going into a state of hibernation.

Would this attract them, do you think? With hive bees this difficulty would be obtained, for they would on arrival be fit to hibernate.—Yours faithfully,

HUMBLE BEES FOR NEW ZEALAND. MR. S. J. ELLWIN writes: 'The advertisement for humble bees for New Zealand has, so far, had the desired effect, and I now beg to inform the readers of the *Journal* that I have obtained and shipped all that I required, and cannot take any more at present. The collection of these coveted fertilisers for New Zealand has been a source of great help to many, and I have heard of some persons who have been enabled to commence bee-keeping by investing the 'shillings' thus obtained.

#### THE PEEL TESTIMONIAL FUND.

Permit me, through your columns, to express my pleasure on learning, through a circular note from Mr. Huckle, that our President has deemed it (and most wisely so) important to summon a meeting to consider what further steps should be taken with the view of completing 'The Peel Testimonial Fund.' That Mr. Peel has deserved well of all bee-keepers and others interested in the work, must be patent to all, for are his deeds not written in the book; and is it not before us that it was only after much pressure on the part of the promoters of the scheme that Mr. Peel yielded to their wishes, and then only conditionally that the testimonial should take such form as to benefit bee-keepers? Why, then, I would earnestly ask, should there be such backwardness in acknowledging his arduous labours and self-sacrifice, copied by unbounded liberality in promoting our work? I sincerely hope the response to any further appeal may be such as will enable the executive to place on record the value and esteem in which Mr. Peel is held by bee-keepers generally, and that in a form worthy of his acceptance.—R. R. COBBREY, *Girlington, November 27th.*

#### NOTTS BEE-KEEPERS' ASSOCIATION.

Seeing the letter from 'A Member of the Committee' in the last number of the *Journal*, I venture to suggest a very simple remedy for the awakening of the Notts Bee-keepers' Association. Let the 'Member of Committee' call his brother members to a meeting *himself*. I feel sure that a meeting is all that is needed to set the machinery in motion. There does not appear to be any acting Secretary, and the question 'What can we do without a leader?' must always receive the answer 'Nothing at all,' or 'Not much,' until some leader is called into existence by the necessity of the case. Let the Committee chosen in May last be called together by the member who wrote to the *Journal*, and let them hold regular meetings. Meetings are the life and soul of an Association. Some one will surely be found to act as Secretary *pro tem*. I should advise the Notts Association to begin in a small way, without incurring any expense, confining its attention at first to enlisting members before attempting anything in the way of sending about an expert and bee-tem, or circulating the *Journal*. Organisation should be its first work; the rest will follow in due time if *only meetings are held regularly*. No further assistance can be expected from the British Bee-keepers' Association until the Notts Bee-keepers have thrown off their apathy and shown some indication of self-help. If the latter will set to work at once they may have their Association organized by the spring. ROLIN HOOD, *Stapleford Forest.*

#### BEE CENSUS.

As the above subject has been raised in the *B. B. J.*, and as it is suggested for all County Associations, it may be of some assistance to show the kind of form used by the Devon and Exeter Bee-keepers' Association. We use return post cards, on the back of the first is printed thus:

DEVON AND EXETER BEE-KEEPERS' ASSOCIATION, Exeter 26th November, 1884. It has been deemed desirable (in the interests of bee culture) to take a census of stocks, and to obtain other information, as per the attached form. The returns will be published 'en bloc' and not individually. If you have no stocks please state the fact and still return the card. While the Council will be most grateful for the extra information as to non-members, they beg that the return may not be delayed beyond the 15th of December. — W. N. GRIFFIN, J. G. DAVEN, *Hon. Secs.*

On the reply post card is printed the name and address of the officer of the society to whom the returns are to be sent, and on the reverse side information is invited on the following matters:

1. The total No. of stocks owned on Lady-day, 1884.
2. Total No. of stocks owned on November 1st, 1884.
3. The No. of stocks owned on November 1st, 1884: a. In bar frame hives; b. In straw hives; c. Other hives.
4. The No. of swarms during the past season.
5. The amount of honey obtained during 1884, in lbs.: a. Comb honey; b. Run honey.
6. The amount of bees' wax in lbs. obtained during 1884.

I do not mean to say that we shall arrive at an exact census, as, although the form is carefully mapped out, the people are very stupid, some even writing across the card; but, at all events, it will help the object in view, of knowing the amount gathered in the British Isles. — W. N. GRIFFIN, *Hon. Sec. D. & E. B. K. A.*

#### THE HONEY YIELD OF 1884.

Now that the honey harvest of 1884 is at an end it would be very interesting if all readers of the *Bee Journal* sent in accounts of the amount of honey they have taken this year from their hives. For the purpose of comparing our own table with that of our fellow bee-keepers

and also of seeing the average yield per hive over the whole country, I suggest that a table be made out in a future number of the *Journal* (say March 1, 1885) on some such lines as I have sketched below. I have filled in two imaginary cases as examples. No notice should be taken in the table of observatory hives, nor of any which have been used for experiments in connexion with foul brood, &c., but all other hives and the honey from them should be reported. A blank form might be sent out with the *Journal* in January to insure having a large number of returns, in the same way as mentioned in the *Journal* for December 1 for North East Ireland. If tables were thus annually made out a far better estimate could be formed of the productiveness of each year.

Name or Initials, and Town.	County.	Nos. of Hives from which honey was taken.	Pun Honey.
X. Y. Z., Stamford ...	Yorkshire	4	110 lbs.
John Jones, Cowbridge	Glamorgan	8	196 ..

Name or Initials, and Town.	Comb Honey.	Total Honey.	Average per Hive.	Remarks.
X. Y. Z., Stamford ...	14 lbs.	124 lbs. 31 lbs.	31 lbs.	Black stocks, 1 Linnæan.
John Jones, Cowbridge	—	196 .. 241 ..	241 ..	1 stock yielded 6 lbs. Increase in stocks was procured to honey.

EDWARD J. GIBBINS, *North.*

#### IMPROVING HONEY FOR MARKET.

Two months ago I described (in a sketch headed 'A Link with the Past') a method of whitening honey communicated to me by an old honey-dealer. I had, at that time, some pure apple-blossom honey, which had not yet granulated; it was dark and thick in consistency, although clear. I emptied part of this into a jam-pot, and well stirred and beat it up with a stick; it immediately began to whiten and granulate, and a considerable quantity of air was mixed up with it, which afterwards rose to the top as a kind of scum. I now enclose samples of the honey. The lot which was untouched is dark in appearance and partially granulated in large unpleasant-looking crystals, while the lot treated as described is many shades lighter, almost solid, and as even in consistency as butter. I believe this treatment will be of considerable value to commercial bee-keepers. It should be carried out when the honey is in bulk, just before it commences to granulate. Its change is simply explained—the agitation causes the honey to 'set' in very fine instead of coarse crystals and therefore alters its appearance.—*Buzz.*

[We have received the samples. We prefer the flavour of the honey in its original form. The appearance of the stirred honey may be more pleasant to the eye, but it has a medicated, 'salvy' look, which, in our opinion, is no improvement.]

#### EDITORIAL IGNORANCE.

I enclose a paragraph descriptive of an engraving of a swarm of bees, which appeared in the *Graphic* for September 13th, of the current year. Your readers will

no doubt be as highly amused with this specimen of 'Editorial Ignorance,' as they were with the one in your recent issue.—EDMUND BALL.

'A SWARM OF BEES.—This is a sight calculated to rejoice the sight of the worthy cottager, who is sitting at his door so contentedly leaning upon his stick.

'The queen-bee of his hive, finding that a rival sovereign has been born who threatens her supremacy, has left her home in search of woods and pastures new, and, attended by some hundred or so of faithful followers, has swarmed upon the bough of a tree until she should fully make up her mind whither she shall bend her wings. Meanwhile her owner has prepared a tempting new hive besmeared inside with the much-loved honey, and his children are endeavouring to dislodge the swarm from their resting-place and drive them towards their new abode by making the most unearthly "morrow-bone" music on frying-pans, tin kettles, and empty pails. If the bees cannot be induced to go into the hive, they may be at least driven to a more get-at-able resting-place, where some bold spirit, protected by a veil and thick gloves, may place the hive over them. It is a curious fact, however, that bees are less apt to sting when swarming than at other times, and many persons have a swarm without either veil or gloves. Bees, however, are exceedingly capricious in their likes and dislikes, and will frequently, for no apparent reason, hold one inmate of a house in the most intense aversion, shown by their constant stings, while another member of the family will never be injured by them.'

#### BEE-KEEPING IN SCOTLAND.

This industry is rapidly spreading over the United Kingdom. Ten years ago Scotland was far behind its neighbours in this work, but at present there are to be found some of the best bee-keepers, who, I am sure, if they would give an account of their past experiences and their present success, it would prove of interest and instruction to many readers of the *Bee Journal*. I have visited a good many of the honey shows, &c., held in Scotland, and can speak of the advancement made during the last eight years. I made the acquaintance this year at Edinburgh of Mr. William McNally, of Messrs. W. & R. McNally, who won so many prizes at the Caledonian Apianian Society's Show. Mr. W. McNally possesses a great knowledge in bee-keeping, and has made me quite an enthusiast on the subject; he might, through the *Journal*, give us a brief account of his life and success, which will interest a great many, not only in Scotland, but elsewhere. I should like very much to have the acquaintance of a good many more of our Scotch heroes: a brief account of their past work will be very much appreciated and at the same time advance the cause. Why keep your lights under a bush?—J. A. B.

[We shall be pleased to place the columns of the *Journal* at the disposal of the gentlemen mentioned in the above communication, and we have no doubt that the story of their experience would prove of interest to bee-keepers generally.]

#### WIDTH OF SECTIONS.—SEPARATORS.

On p. 347, vol. xii., Mr. J. C. Lambert asks a question as to sections  $1\frac{1}{2}$  wide without separators. At an earlier date, when describing the kind I use, I gave  $1\frac{1}{2}$  as the width necessary to obtain one pound in weight when no separators are used. I find such give me as nearly the pound as possible, with American  $4\frac{1}{2}$  by  $4\frac{1}{2}$ , or my own  $4\frac{1}{2}$  by  $4\frac{1}{2}$ .

No doubt many others, like Mr. Lambert and myself, have found separators a nuisance, nevertheless considerable care is required when not using them. The hives should stand quite level when supers are on, or few combs will hang true in the sections. An inexpensive spirit-level should be obtained, and used when supering, and occasionally afterwards if one has the

least suspicion that the position of the hive has changed.' Also examine at intervals and correct any irregular combs that may occur before too far advanced, though this will seldom happen with strong colonies. And, too, on removing finished sections, it is absolutely necessary that all less advanced combs should be kept together in proper order—the most forward at the centre, and so on with those thinner towards the ends of the row, adding sections with foundation at the outside as required.

A lot of trouble some will say, but the question is, 'Is it more trouble, and is more time occupied than when manipulating with separators?' My own experience is that there is less trouble, less time occupied when manipulating, less propolis used, and no separators to clean; and while I can obtain ninety-five per cent of combs that can be glassed, I shall not return to their use.—SAMUEL SIMMONS.

## Foreign.

### SWITZERLAND.

The *Bulletin d'Apiculture* publishes a lengthy report upon an apicultural journey made through Alsace by its editor and Mr. Cowan, in the course of which they have visited several bee-keepers of note. According to the same journal the apicultural classes, held at Zoug by Mr. J. Jeker in the course of the summer, were attended by fifty pupils.

The *Société Romande d'Apiculture* held a general meeting of members at Vevey, with M. Bertrand in the chair. In the course of his address he stated that their greatest enemies were the manufacturers of honey and the hotel-keepers who sold it in their establishments. The injury, he said, they make is very considerable, for through their instrumentality the good name of our honey is compromised even abroad. It is not, he remarked, sufficient to produce honey in large quantities and then wait until people call for it at our doors. We must follow the Americans and the English, who are creating quite a demand for the product of their bees by offering it to the public put up in marketable and attractive forms, and contrive to have their honey mentioned by the public press. He closed his speech by calling upon every bee-keeper individually to use his best endeavours to increase the consumption of honey wherever that was possible.

### FRANCE.

A general Agricultural Exhibition, including Apiculture, is to be held in the 'Palais de l'Industrie' of Paris, between the 2nd and the 11th of February, 1885. Honey exhibits must not weigh less than 4 kilos, (10 lbs.), and wax, 10 kilos, (25 lbs.).

#### HONEY.

- One gold, four silver, and six bronze medals.
- 1st group—Honey in the comb for the table.
- 2nd ditto—Run honey from the heather districts.
- 3rd ditto— " " from artificial meadow districts.
- 4th ditto— " " from the mountains.

#### WAX.

One gold, two silver, and two bronze medals.

Besides the above, the Ministry of Agriculture has already decided to grant special prizes of honour, consisting of gold medals of various sizes; also special silver ones for improvements in the cultivation of the honey bee.

Further particulars will be published shortly; in the meantime notice is given that all applications for space will have to be addressed to the French Ministry of Agriculture and Commerce in Paris, not later than the 1st of January, 1885.

## Echoes from the Hives.

*Devonshire.*—For some months I have been unable to send you any echoes, but all the readers of the *B. B. J.* will have seen that during this time I have been working in different parts in the cause of apiculture and thus prevented.

First let me make up the deficit of the rain-fall as follows:—

	1884.	1883.
July .....	3.09	4.71

Greatest amount in twenty-four hours, 9.08 on the 15th. There were nineteen wet days. In 1883 there were twenty-four wet days.

	1884.	1883.
August .....	2.17	2.15
September .....	2.14	6.46
October .....	1.19	3.97
November .....	2.03	3.97

Number of wet days, 15. Number of wet days, 10.

Winter weather has now set in, and bee-keepers are discussing the result of the past grand season.—Wm. N. G., *Hon. Sec., D. and E. B.K.A.*

*Abingdon, Dec. 14th.*—The weather has been very cold for a long time in Abingdon, and last Saturday night there was a very sharp frost. I placed a yellow dish out in the garden filled with water, near the bees, and in the morning it was a solid block of ice. Thinking my bees must have suffered from the frost I went to a straw skep, and to my surprise they were all of a gentle hum, which proved they were comfortable. A slight tap on the flight-board brought about a dozen to the entrance, which had a look round and returned in the hive. Now I have left one of my improved supers on with 12 lbs. of honey on this skep for the bees to winter on, and I have taken away in super 50 lbs., not including the 12 lbs. left on the skep. D. BICKELAND.

*Essex.* I commenced with a bar-frame hive and one skep, which cost 28s.; feeding through the winter cost 12s.; and I bought since three bar-frame hives and three skeps, which cost 27.11s.—the total outlay, with a few extra expenses, being about 50s., and this outlay is fully balanced by the present stock in hand. Thus the yield of honey—which was 186 lbs., equivalent to a monetary value of nearly 10%—is clear profit. One bar-frame hive yielded 48 lbs. sections and 32 lbs. of run honey. SCINTILLA.

## NOTICES TO CORRESPONDENTS & INQUIRERS

A. H. P.—*Sugar.*—In your list of different kinds of sugar, the centrifugal, or 'coffee' or 'white crystal' (at one time called Finze's) is the nearest to that mentioned by us, and will answer your purpose. 2. *Small portions of wax.* The small portions of wax on the division-board had been placed there by the bees, probably in late autumn, with the intention of uniting it to the next comb by strips, or side props, of wax. This is generally done in strong colonies. Do not disturb the bees at this season.

GREAT CLACTON.—1. *Enamelled Cloth.*—Of the two samples of cloth the best for your purpose is the darkest—American enamelled. The other specimen—imitation mahogany—is the common 'table oil-cloth,' and would not answer for this purpose. Do not put it into use until late February or early March. The propolis should be removed from the top-bars of the frames so that the cloth—enamelled side downwards—may be laid upon a smooth level surface. It will be of advantage to the bees. 2. *Thin Honey.*—The thin honey surrounding the brood-nest had not been 'ripened,' i.e., evaporated by the bees. If mixed with honey of thicker consistency it would rise to the

surface, and, in a warm atmosphere, would gradually ripen. We prefer allowing the bees to ripen the honey in the hive, and to extract only sealed, or partially-sealed, combs; never those containing brood—believing that the centrifugal force, requisite for casting out the honey, injures the eggs, larvae, and pupæ, removing the very stores intended for these.

3. *Extractor*.—We have no experience of the extractor to which you refer, but do not believe in the principle.

CONSTANT READER.—*Cyprians and Syrians*.—1. As to docility and temper, there is little difference between Cyprians and Syrians. The latter, perhaps, are the quietest to manipulate. With gentleness and judgment there is no difficulty with either. 2. We think Syrians the best honey-gatherers. 3. There is little difference in the swarming propensity of the two races. The Syrians we think most prolific, and, therefore, productive of most swarms, if allowed full liberty. 4. In an amateur's, or, indeed, in any apiary, we recommend the Syrians.

W. T. B.—*Granulation of Sections*.—The granulation of comb-honey is generally caused by a low temperature. Sections should be stored in a dry room in which the temperature should not be below 50° Fahr. The honey collected from certain flowers granulates much sooner than that from others. The late frosty weather has, no doubt, solidified your sections, and as such they are generally unsaleable. Honey taken from the top of hives is not more liable to granulation than that from the body or outside of the hive. In severe winters we have known the whole hive-stores to become crystallised, and the bees to perish in the midst of plenty. In your case we advise you to melt your sections, skimming off the wax as it rises. If too much heat is not applied the honey from light-coloured sections will be superior, and will not be liable to granulation after the process.

A. F. RAMSDEN.—1. *Moving Bees*.—Wired foundation: this will be less liable to break down, but as it is not so good for the bees we should not recommend its use. If you prepare your hives properly and give plenty of air, ordinary combs will travel safely in October next. 2. *Roofs* should fit on to the hives so closely as not to admit robbers, the necessary ventilation being obtained by holes under the eaves covered with perforated zinc.

J. E. L. GILBERT.—*Candy*.—1. Of the samples you send, the darker is the best made, but being from raw sugar it is not so good for bees. The other is made from better sugar, but too much boiled, therefore too hard and crystalline; use refined sugar and do not boil so much. 2. The Rev. T. Sissons, Beckenham, will be happy to explain his *modus operandi*. Citric acid, or cream of tartar (bi-tartrate of potash), will prevent crystallisation. 3. Yes. 4. Mr. Hewitt recommends candy and, we believe, condemns Mr. Simmins' dry sugar feeding, which others speak well of. 5. Mr. Simmins uses hives on the old-fashioned plan, with frames end on to the entrance. In 'Combination' hives put the dry-sugar feeder at the back of the frames. 6, 7. The rearing of queens is pretty well decided in the book you name. Pending the publication of another work, you had better keep abreast of the current literature, British and American. Have you read Alley on Queen-rearing? 8. To fully describe a section rack would take up too much space; write to the principal makers, such as Abbott Bros., Baldwin, and Neighbour, for catalogues, and make your selection.

M. T.—*Transferring from Skeps to Frame-hives*. It is generally recommended to wait until twenty-one days after swarming and then transfer, and this is very good advice to novices, as the omission of certain precautions may lead to disaster. Experienced bee-keepers have no hesitation in transferring at any time when the weather is warm; and if your object is to build up

an apiary from a few stocks, you can do that better when you have that command of your bees which bar-frame hives give you. 2. Ligurians, or the first cross between them and blacks, are the best bees all round. Syrians and Cyprians are at present very expensive and their superiority not yet established in so marked a degree as to recommend them.

GEORGE MORRISON.—As your address is in Glasgow, we would suggest that you should consult Mr. R. J. Bennett, 50 Gordon Street, Glasgow, who will be happy to give you all the information you seek. The agent for the *Journal* is Mr. R. McNally, Glenluce. We do not know that there are in Scotland any 'experts' similar to those the County Associations have in England, but there are many advanced and skilful bee-keepers there.

L. M. L.—*Wax-moth*.—The safest guard against the wax-moth is to have strong stocks. The larvae of the moth can be destroyed by means of sulphur. If all the eggs are destroyed, the combs may be utilised; but now that foundation is so cheap it would prevent many risks by melting the old comb and making the bees build new.

J. M. S.—We have not been favoured with the details of the arguments which have led the gentlemen you mention—many of whom are advanced bee-keepers—to the conclusions at which they have arrived; but the methods which they condemn have been, and are, adopted and recommended by some of the most scientific and practical men we have, and to their opinions we should incline. Sulphur fumes are not beneficial to the combs themselves, rather the reverse, but they destroy wax-moth grubs, and tend to prevent fermentation of stores, if any.

THE FILTER.—*Commencing Bee-keeping in Africa*.—The climate of Tunis is a most favourable one for bees, and the rose-mary yield-honey of fine aroma and quality; it is in fact the plant from which the justly celebrated Narbonne honey was originally collected, although at the present time there is little, we believe, to be found in that part of France. We should advise you to procure thoroughly sound, well-made, English *Combination hives*, of pine-wood, double-walled, and well painted, containing at least 14 Standard English frames, and to aim at extracted honey only. You could not do better than to take out Cowan's *Automatic extractor*. Go to a first-class English dealer in hives for these articles. Your apiary will require shade in such a climate as that of Tunis. If you cannot obtain natural shade, you may procure artificial by raising trellis-work for each hive, and training vines over it—a practice much in vogue in the hotter parts of the United States of America. When established we shall hope to be favoured with a report of your success for publication in our columns. It is most important that the hives should be double-walled—more so, indeed, in a hot than in a cold climate—and the spaces between the walls should be filled with cork-dust—a practice common in England now. Commence with Italian bees, and when established cross them with Syrians.

BUSY BEE, Birmingham.—Be pleased to favour us with your name and address.

The letters directed to 'John Peel' have been forwarded to the correspondent assuming that *nom de plume*.

A number of Subscriptions expire with the present issue. The expiry is indicated to the Subscribers in the usual way. An Order Form for the renewal of the Subscription accompanies the Journal, which is sent in a coloured wrapper.

The Volume for 1884, bound in cloth, will be ready shortly. Price Seven Shillings. Covers for binding can be supplied at One Shilling each.

**Special Prepaid Advertisements.**

For Sales and Purchases of Bee Appliances, Honey, Books, Pamphlets, Diagrams, &c., Exchanges and Situations.

*Terms: Twelve words and under, Fourpence; for every additional three words, One Penny extra; no reduction can be made for continuous insertion.*

Advertisements will not be received for insertion under this heading from Manufacturers or Dealers in Bee Furniture, except for the Sales of Honey and Bee Literature.

**SPECIAL NOTICE.**—We cannot under any circumstances be responsible for the truth of statements made in Advertisements, or for the trustworthiness of either Buyers or Sellers.

**THE SIMMINS' METHOD OF DIRECT INTRODUCTION.** Enlarged to 32 pages. Price 6<sup>hd</sup>. Post free, of the Author, Nottingham, Brighton; Messrs. NICHOLSON & SONS, 119 Regent Street; and Mr. J. HUCKLE, Kings Langley, Herts. (53)

**BEE-KEEPING, Plain and Practical: How to Make it Pay.** By A. RUSSELL. 1s. 6<sup>hd</sup>, post free, Is. 8<sup>d</sup>. Address J. HUCKLE, Kings Langley, Herts.

**BINOCLULAR MICROSCOPE** By SWIFT. Good as New. Mechanical stage, 1½ in. Three Eye-pieces, Stand, Condenser, Polariscopes, Selenites, Spot Lens; Live-box, Three pairs Forceps, Slide Reflector, Camera lucida, &c., in Mahogany Cabinet. £16, lowest. Apply Editor, *British Bee Journal*.

**WANTED** about 40 Hives, frames across entrance; 2 cwt. Thick Foundation, some Super; lot of American Sections, Smokers, Super Section Crates, Feeders, &c. Address J. S. BOLTON, Colchester. 100

**FOR SALE**, about 1 cwt. Pure English Honey, in bulk or lots to suit purchasers. 8<sup>d</sup> per lb. Apply J. CUTHBERT, Dowlish Wake, Hunslet, Somerset. 1

**EIGHT HEWITT'S EXCELSIOR HIVES.** 56s., or 7s. 6<sup>hd</sup>, each; also COMB STAND and 30 SIMMINS' FEEDERS, cheap. Address MUSLE, St. James, Northampton. 98

**LIMNANTHES**, Strong Plants, 1s. per 100, free. Apply SAYER, Monument Lane Wharf, Birmingham. 3043

**FOR SALE**. — LIMNANTHES, Plants very strong, 1s. 6<sup>hd</sup>, per 100, carriage free. Address H. E., The Lodge, Stoneleigh, Ewell. 639

**BRITISH BEE JOURNAL**, 1875, 1876, 6s. per year, or 10s. 6<sup>hd</sup>, for two years.

**LIMNANTHES**, best Food for Bees in Spring, 9<sup>d</sup>, per 100, 1s. 9<sup>d</sup>, per 1000. Address E. JACKSON, Welwyn, Herts. 3040

**Jackson's Rheumatic Embrocation.**

Mrs. P. writes: 'I am gaining the use of my hand since using your Embrocation.'

Cures Rheumatis, Sciatica, Neuralgia, Tic, Lumbago, &c.

Post free for 1s. 4<sup>d</sup>, from J. R. JACKSON, Welwyn, Herts. 3040

*Will be sent post free on receipt of Two Stamps.*

**THE AMATEUR'S GUIDE IN BEE-KEEPING.**

**A. G. DAWSON,**  
ALMA BUILDINGS, MACCLESFIELD. (75)

**Imported Carniolans and Italians.**

Sent post paid, with safe arrival guaranteed.

I have several times visited both Carniola and Italy, inspecting each time a large number of apiaries, and am thus enabled to make the best selections of stock.

Grades & Prices of Queens.	Spring.	June.	July & Aug.	Fall.
Finest Selected Queens, each	12s.	10s.	8s.	7s. 6 <sup>hd</sup> .
Fine Prolific Queens, each	9s.	8s.	7s.	6s.

Any six queens, 5 per cent discount; ten queens, 10 per cent; fifty queens, 12 per cent; forty queens, 15 per cent.

**A SPECIAL OFFER.**

From any cash order made before Jan. 1st, 10 per cent may be taken off. If six or more queens are ordered this deduction is to be made after the regular discount above mentioned has been subtracted. Remittances by blank postal notes, international postal order, or by bank notes in registered letters.

**FRANK BENTON, Munich, Germany.**

**FEEDER DUMMIES.**

**THE GREATEST SUCCESS** has followed the use of HOLE'S NEW FEEDER DUMMY. A large number are being sent out daily, and in consequence of the general satisfaction they are giving I am extending arrangements for a more rapid supply, confident that where syrup feeding is practised the old method of inverted bottle, or the various float-feeders, will be discarded by most Bee-keepers who have tried the Dummy Feeder. Post free, 1s. 6<sup>hd</sup>. An adaptation of SIMMINS' SUGAR FEEDER, post free 8<sup>d</sup>.; three, 1s. 6<sup>hd</sup>. Either kind of Feeder cheaper in quantity.

**HEREFORDSHIRE SCHOOL OF APICULTURE, TARRINGTON, LEDBURY**

The only Weekly Bee-Paper in the World.

**THE AMERICAN BEE JOURNAL**

*Established in 1861.*

Edited and published by THOMAS G. NEWMAN, at 925 West Madison Street, Chicago, Illinois, U.S.A., and will be sent to European Subscribers at 10s. 6<sup>hd</sup> per annum for the Weekly, or 5s. for the Monthly, including Postage. The money may be sent by International Postal Money Orders on Chicago. London Agents: Messrs. GEO. NICHOLSON & SONS, 119 Regent Street, W.

**Publications of the British Bee-keepers' Association:**

**HONEY AS FOOD.** By FRANK R. CHESNAR, Esq., F.R.M.S. Price 3<sup>d</sup>.

**HONEY-BROOD: THE MEANS OF ITS PREVENTION, AND THE METHOD OF ITS CURE.** By FRANK R. CHESNAR, Esq., F.R.M.S. Price 6<sup>d</sup>.

**A DELIBERATION ON HONEY.** By OTTO HENRIC, Esq., F.C.S., F.I.C. Price 6<sup>d</sup>.

**THE CHEMISTRY OF THE HIVE.** By Mr. OTTO HENRIC, F.I.C., F.C.S. Price 3<sup>d</sup>.

**THE BEST WAY OF INSTRUCTING COTTAGEERS IN THE ART OF BEE-KEEPING.** By the Rev. W. E. BRIDALL. Price 3<sup>d</sup>.

**WINTERING BEES.** By THOMAS W. COWAN. The most complete work on the subject of Wintering published. Price 3<sup>d</sup>.

**BEE HOUSES AND HIVES.** By Rev. GEORGE RAYSON. Second Edition (enlarged). Price 6<sup>d</sup>.

**THE SOCIAL INSTINCTS OF BEES.** By G. D. HAYLAND. Price 3<sup>d</sup>.

**MODERN BEE-KEEPING.** An Illustrated Handbook for Cottagers. Fourth Edition, considerably enlarged. The soundness of its information, the simplicity of its instruction, combined with cheapness, make this Handbook invaluable to all intending Bee-keepers. Price 7<sup>d</sup>, post free.

Address **J. HUCKLE, Kings Langley, Herts.**

# THE BRITISH HONEY COMPANY.

TRADE MARK, REGISTERED.

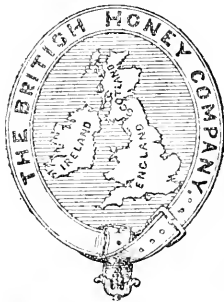

**PROPOSED CAPITAL, £20,000**

(WITH LIMITED LIABILITY),

**IN 20,000 SHARES OF £1 EACH**

5s. per Share proposed to be called up.

THE Directorat has been formed, and Offices have been secured in the immediate neighbourhood of Charing Cross. The Memorandum and Articles of Association have been finally approved, and the Company will be duly registered in the course of the next few days.

## The Bee and Fruit Farming Co., Limited.

**CAPITAL £10,000, in 10,000 SHARES of £1 each,**

Payable 5s. on Application, 5s. on Allotment, and the balance when required.

**DIRECTORS.**

- \*JESSE GARRATT, Esq., Hoekenden, St. Mary Cray.
- LAWRENCE GREEN, Esq., Tovil House, Maidstone.
- JOHN M. HOOKER, Esq., Sevenoaks.
- FREDERICK H. JUDSON, Esq., Coventry Park, Streatham, S.W.
- JOHN MARTEN, Esq., Dunkirk House, Faversham.
- HENRY GRAVE MORRIS, Esq., Belmont Hill, Lee, S.E.

**SOLICITORS.**—MESSRS. ASHURST, MORRIS, CRISP & Co., 6 Old Jewry, London, E.C.

**BANKERS.**—MESSRS. GLYN, MILLS, CURRIE & Co., 67 Lombard Street, London, E.C.

**SECRETARY (pro tem.)**—Mr. F. M. EDWARDS. **OFFICES.**—BERRY DOWNS, ST. MARY CRAY.

\* Mr. GARRATT will join the Board as Managing Director after the allotment has been made.

THE principal object for which the Company has been formed is to assist Bee-keepers by providing a ready means for disposing of the Honey and Wax now being produced on a large scale, and to meet the difficulty experienced by so many of finding a quick market for their produce. The Company will purchase Honey, Wax, and Bees, direct from its Shareholders, and will also sell upon Commission when preferred.

**ADVERTISER.** First-class Amateur Carpenter and Practical Bee-keeper, having spare time, will MAKE ANY DESCRIPTION OF HIVE, charging only for time and material. Awarded Second Prize for Hive, Lincolnshire Show, 1884. Address JAS. GILBERT, Apianian, Stamford. 3014

**HONEY.**—Having facilities for the sale of large quantities, I am prepared to receive offers (accompanied by samples carriage paid) of Sections and Extracted Honey, in quantities of not less than 30 lbs. of one quality. Address F. LYON, 94 Harleyford Road, London, S.E.

**EDEY & SON'S**  
**HUMANE BAR-FRAME HIVES,**  
And BEE-KEEPERS' SUPPLIES,

Manufactured on Scientific Principles, by an experienced Staff of Joiners, with the aid of Modern Steam-power Machinery.

ENGLISH AND FOREIGN BEES AND QUEENS,  
HONEY AND WAX, at Market Prices.

**SPECIAL OFFER.**—Having purchased Manufacturer's Stock of WOVEN WIRE for VEILS, can offer 20 per cent off list prices for pieces of ten yards. Veils, 2/- each.

Illustrative and Descriptive Catalogue per  
**THOMAS EDEY & SON,**  
STEAM JOINERY WORKS, ST. NEOTS.

### Important Notice to Amateur Hive-makers.

**Standard Frames in the Flat,**

Tenoned and Morticed, requiring no block to make, with 17 in. solid Top-bars, per gross 10s.; with split Top-bars, per gross 12s. 6d. Can be used with Metal Ends.

**SECTION CRATES,**

Dovetailed, in the Flat, for 4½ by 4½ Sections.

To hold 7lb. per doz. ...	7/6	Sections & Dividers ...	3/9
.. 14lb. " ...	9/0	" " ...	7/6
.. 21lb. " ...	12/0	" " ...	11/0

No less quantities supplied, and we do not undertake to fill orders at above prices after March. *Terms Cash.*

**E. M. HART & Co.,** The Longstock Hive Manufactory,  
STOCKBRIDGE, HANTS. (90)







