

APPLEBY'S ILLUSTRATED HANDBOOK OF MACHINERY.

SECTION IV., MACHINE & HAND TOOLS,

INCLUDING

WORKSHOP CONSTRUCTION, WITH PLANS, SECTIONS AND
DESCRIPTIONS OF ENGINEERING SHOPS, AND
THEIR EQUIPMENTS;

MACHINE TOOLS FOR WORKING METALS, WOOD, Etc.,
AND THEIR ACCESSORIES,

MECHANICS' TOOLS, SHAFTING, PULLEYS, BELTING, &c.
FILES, SAWS, AND ENGINEERING STORES,

WITH

*PRICES, WEIGHTS, MEASUREMENTS, AND SOME DATA ON WORKING
EXPENSES AND RESULTS OBTAINED.*

BY

C. J. APPLEBY, M. Inst. C.E.,

[JESSOP & APPLEBY BROS., (LEICESTER & LONDON,) LIMITED.]

22, WALBROOK, LONDON, E.C.

Telegraphic Address—"MILLWRIGHT, LONDON."

ABC, MOOREING'S, THE A1, AND THE FOLLOWING CODE USED.

SECOND EDITION.

PRICE 3/6.

LONDON:

E. & F. N. SPON, LIMITED, 125, STRAND.

NEW YORK:

SPON & CHAMBERLAIN, 12, CORTLANDT STREET.

1897.

[ALL RIGHTS RESERVED.]

[ENTERED AT STATIONERS' HALL.]



133148
SEP 30 1909

6722315

TR
AP5
4

NOTICE.

Owing to the increased cost of labour and materials since the publication of this book, the printed prices are no longer reliable, and about ten per cent. should be added to cover this increase.

1st January, 1904.

APPLEBY'S HANDBOOK OF MACHINERY.

—O—

The Edition published in 1869, and several reprints of it having been exhausted, a New Edition (of which this section forms a portion) is now being completed; and for the convenience of those who desire information on specific subjects, but not on all those treated, the book is divided into seven sections, each of which may be obtained separately as follows:—

SECTION 1.—PRIME MOVERS.

STEAM, GAS AND AIR ENGINES, BOILERS, TURBINES, ETC.

SECTION 2.—HOISTING MACHINERY.

WINDING ENGINES, HYDRAULIC, STEAM, ELECTRICAL AND HAND CRANES.
WINCHES, JACKS AND OTHER LIFTING APPLIANCES.

SECTION 3.—PUMPING MACHINERY.

PUMPING ENGINES, CENTRIFUGAL, STEAM, ELECTRICAL AND HAND PUMPS.

SECTION 4.—MACHINE TOOLS

AND ACCESSORIES.

FOR WORKING METALS, WOOD, ETC.

SECTION 5.—CONTRACTORS' PLANT AND RAILWAY MATERIALS

INCLUDING MACHINERY AND MATERIALS FOR THE CONSTRUCTION AND
EQUIPMENT OF RAILWAYS AND OTHER PUBLIC WORKS.

SECTION 6.—MINING, COLONIAL AND MANUFACTURING MACHINERY.

FOR TREATING ORES, CORN, COFFEE, RICE, SUGAR, COTTON, AND OTHER
PRODUCTS, OIL MILLS, ICE MAKING, DISTILLING, ETC.

SECTION 7.—USEFUL TABLES AND MEMORANDA.

FOR ENGINEERS, MERCHANTS, AND MANUFACTURERS.

Each Section, bound in cloth, is sold separately, price 3/6 each.

The subject matter has been entirely re-written, and is illustrated by a large number of Engravings which (for the most part) represent work carried out by the Author's Firm.

The arrangement is intended to be in a handy form for reference, useful alike to engineers, users, and to purchasers of machinery and of materials connected therewith.

The prices are based on the present cost of materials and of labour and these—as well as details of design and proportions—are necessarily subject to modification without notice.

Some data is given with reference to the cost of working, motive power required and work performed; also approximate weights and measurements, so that the results obtainable and the total cost including freight, import duties, &c., may be roughly estimated. The cost of packing for shipment and delivery to docks varies with the nature of the packing required and the destination, the rates given being the average as nearly as they can be determined.

Code Words for each kind of machine will be found in the index, and these, in conjunction with the sentence words in Appleby's Copyright Telegraph Code which precedes the Index, will usually suffice for correspondence by cable; by specifying the price, Fig. No., or page in figures, the leading dimensions of the tool required can be indicated. An example of the mode of using this and other codes will be found at page IV.

PREFACE.

Much information relating to the matters referred to in the following pages will be found in text books, treatises, and trade catalogues, but it is treated, for the most part, in a manner too technical to be of real service to many who—although buyers and users of machinery—may not possess intimate knowledge of details of construction, the cost of machines, their productive capacity, &c.

Conscious, as the Writer is, that the efforts of no single individual will suffice to cover the ground thus left vacant, he has attempted to cover some of it by presenting information with regard to the construction, the approximate prices of the machines described, the probable output, and other data which will serve as a basis for estimating the cost of the machinery and, approximately, the cost of working it.

The arrangement adopted in the first edition of APPLEBY'S HANDBOOK OF MACHINERY, which was published in 1869, has been to a large extent adhered to in this edition, but the advances made in all branches of mechanical construction since that time, have been so incredibly great and varied, that nothing which appeared in the above-named edition, or the numerous reprints of it, have been found suitable for reproduction, so that the descriptive matter has been entirely re-written and—as far as practicable—corrected up to this date.

Details are given of appliances in general use, but the space available does not admit of adequate notice of others which, however, give excellent results under conditions differing from those referred to.

NOTES

ON THE SECOND EDITION.

It is necessary in the present edition to direct attention to the general advance in the cost of materials and labour which has taken place since 1895, when the last edition was published.

These advances naturally enhance the cost of production, but it seems undesirable to disturb well established prices until it has been seen to what extent the present increase in cost will be maintained; in the meantime perhaps every purpose will be answered if—for approximate estimate—about 10% (ten per cent) is added to the prices which will be found in the following pages.

Additions have been made to the Telegraphic Code and some data is given with reference to recent developments in the use of electric transmission of power for driving Metal and Wood Working Machines which have hitherto been driven by shafting, belts, &c. Examples are also given of useful machines with appliances whereby the electric current is employed to fix the tool and provide the motive power for working it.

London,

December, 1897.

APPLEBY'S COPYRIGHT TELEGRAPHIC CODE

FOR CORRESPONDENCE BY TELEGRAM.

NOTE.—CABLE ADDRESS: "MILLWRIGHT, LONDON."

The code numbers are for use in case a repetition of the telegram may be necessary.

ENQUIRIES AND QUESTIONS.

- 191290 **Taaier** ... Telegraph how soon you could ship the following, viz.
- 191291 **Taaheid** ... Reply, by letter, how soon you could ship the following, viz.
- 121292 **Taainagel** ... { Telegraph at what price, packed and delivered f.o.b. English port,
you could supply and ship the following, viz.
- 191293 **Taalboek** ... { Reply, by letter, at what price, packed and delivered f.o.b. English
port, you could supply and ship the following, viz.
- 191294 **Taaldeel** ... { Telegraph how soon and at what price, packed and delivered f.o.b.,
you could supply and ship the following, viz.
- 191295 **Taaleigen** ... { Reply, by letter, how soon and at what price, packed and delivered
f.o.b. English port, you could supply and ship the following, viz.
.....
- 191296 **Taalfout** ... { Telegraph name of vessel by which you have shipped.
- 191297 **Taalgebrek** ... { We learn that the.....with your goods on board has been lost.
Shall we replace?
- 191298 **Taalgids** ... { Telegraph, at my expense, how soon my order will be despatched.
- 191299 **Taalgrond** ... { Reply, by letter, how soon my order will be despatched.
- 191300 **Taalkundig** ... { Do you wish us to proceed with order?
- 191301 **Taalman** ... { Will you leave matter to our discretion?
- 191302 **Taalregel** ... { When will remittance be sent for £.....
- 191303 **Taalschat** ... { Send us a complete tracing of.....
- 191304 **Taalteeken** ... { Send us a photograph of.....
- 191305 **Taalvitter** ... { Send us a complete estimate for the following.....
- 191306 **Taalvriend** ... { Prepare design and send tracing and estimate including delivery
f.o.b. for.....
- 191307 **Taalwet** ... { Can you alter the goods to our order as follows.....
- 191308 **Taalzifter** ... { How soon can you deliver?
- 191309 **Taanbloem** ... { Have you in stock?
- 191310 **Taartblik** ... { A reply by wire is requested.
- 191311 **Taarten** ... { A reply by first mail is requested.

ORDERS AND INSTRUCTIONS

- | By Sailing Vessel. | Steamer. | Mail Boat. | |
|----------------------------|-----------------------------|---|---|
| 191312
Taartepan | 191313
Taartjes | 191314
Taartkoek | } |
| 191315
Tabacca | 191316
Tabacalero | 191317
Tabacales | |
| | | | |
| 191318 | Tabaccasse | .. No part of the machine must weigh more than.....cwt.s. | |
| 191319 | Tabacchi | .. We leave matter to your discretion. | |
| 191320 | Tabacomane | .. Preferring them in the order named. | |
| 191321 | Tabacosas | .. Payments will be made by..... | |
| 191322 | Tabacoso | .. Payments will be made by..... | |
| 191323 | Tabagie | .. Terms will be as before. Arrange terms with that firm | |
| 191324 | Tabagique | .. Remittance is delayed until..... | |
| 191325 | Tabahia | .. Draw on us at sight for £..... | |
| 191326 | Tabakasche | .. Draw on us at..... | |
| 191327 | Tabakbau | .. Await instructions for shipment. | |
| 191328 | Tabakbeize | .. Replace with all possible despatch. | |
| 191329 | Tabakdampf | .. Duplicate our order of..... | |
| 191330 | Tabakkorb | .. Repeat our order for..... | |
| 191331 | Tabakladen | .. Repeat our last order. | |
| 191332 | Tabakqualm | .. Await our letters before proceeding. | |

Orders and Instructions—Continued.

191333	Tabakrauch	.. Same pattern or quality as before.
191334	Tabakreibe	.. The same as you last supplied.
191335	Tabakrolle	.. Same as supplied by you in.....
191336	Tabaksblad	.. Same as supplied by.....in.....
191337	Tabaksbouw	.. Same as supplied to.....in.....
191338	Tabaksland	.. Draw on us for £.....at the following number of days from sight.
191339	Tabakspijp	.. Please deliver at once.
191340	Tabaksrook	.. Please deliver next week.
191341	Tabakstube	.. Must be inspected by.....
191342	Tabaksvat	.. Ship at once.
191343	Tabaksveldhas been irreparably damaged send another.
191344	Tabakszakhas been lost replace it immediately.
191345	Tabaleabau	.. Please send by next mail certificate for
191346	Tabalera	.. Prepare for delivery at once.
191347	Tabaleos	.. Wanted for immediate delivery.
191348	Tabalhiom	.. The makers were (are).....
191349	Taballiado	.. As described in Appleby's Handbook of Machinery, price £.....
191349	Tabanidae	.. As illustrated in " " " Fig.....
191349	Tabanus	.. As described in " " " page.....

ANSWERS, &c.

191350	Tabanca	.. Freight will add about.....per cent. to the f.o.b. cost.
191351	Tabanidae	.. The machine will weigh about.....cwts.
191352	Tabaquear	.. The total weight will be about.....tons.
191353	Tabaqueiro	.. The total measurement will be about.....cubic feet.
191354	Tabaqueras	.. No part of the machine will weigh more than.....cwts.
191355	Tabaqueurs	.. The machine is finished.
191356	Tabaquista	{ We can supply you with goods, as per your enquiry, at the following net price.
191357	Tabardelha	.. Please telegraph credit with some English Bank for order just received.
191358	Tabarder	{ The credit opened with the Bank is too small; please to telegraph further credit for £.....
191359	Tabardilho	.. We cannot execute order on other terms.
191360	Tabarzet	.. We have remitted you by letter £.....
191361	Tabatiere	.. Cash will be paid against Bill of Lading by.....
191362	Tabaxir	.. Machinery is shipped by steamer.
191363	Tabbard	.. Machinery will be shipped by steamer.
191364	Tabbaoth	.. Machinery is shipped by sailing vessel.
191365	Tabbinet	.. Machinery will be shipped by sailing vessel.
191366	Tabbying	.. Your order received and has our best attention.
191367	Tabebuia	.. Remittance follows by mail.
191368	Tabefatto	.. Remittance will be sent immediately for £.....
191369	Tabefied	.. Waiting your remittance.
191370	Tabellaria	.. Credit arranged through.
191371	Tabellaron	.. Credit arranged by telegraph.
191372	Tabelle	.. £10 additional needed to cover cost.
191373	Tabelliar	.. £20 " " "
191374	Tabellioa	.. £30 " " "
191375	Tabellions	.. £40 " " "
191376	Tabellone	.. £50 " " "
191377	Taberd	.. £60 " " "
191378	Tabergite	.. £80 " " "
191379	Tabernacle	.. £100 " " "
191380	Tabernero	.. £ " " "
191381	Tabescence	.. We can deliver from stock.
191382	Tabescent	.. " " in one week.
191383	Tabetique	.. " " in two weeks.
191384	Tabicadas	.. " " in three weeks.
191385	Tabicamos	.. " " in four weeks.
191386	Tabicar	.. " " in six weeks.
191387	Tabicarón	.. The time for delivery should be.....weeks.
191388	Tabicones	.. The time of delivery is of great importance.
191389	Tabido	.. All charges will be accounted for.....
191390	Tabificas	.. All charges will be paid by.....
191391	Tabifui	.. I (we) cannot promise delivery until.....
191392	Tabifuos	.. I (we) cannot promise delivery in the time stated, letter follows.

Answers, &c.—Continued.

191393	Tabiosis	.. { I (we) cannot promise delivery in time stipulated, please telegraph instructions.
191394	Tabique	... We have not received yours of the.....
191395	Tabiqueis	... Replying to your telegram, (enquiry) our price is £.....
191396	Tabiquemos	{ Replying to your telegram, our price, subject to prompt confirmation of order, will be £.....
191397	Tabiser	... Full information follows by mail.
191398	Tablacho	... Tracing and estimate will be sent.
191399	Tablabo	... Tracing and estimate were sent.
191400	Tablajero	... We have received your order for.....

GENERAL MESSAGES.

191401	Tablares	... steamer is delayed by having to put in at.....
191402	Tablazones	... is erected and works satisfactorily.
191403	Tablazos	... is erected but does not work satisfactorily.
191404	Tableabais	{ is erected but does not yet work satisfactorily, send immediately by quickest route.
191405	Tableadas	... will leave on or about the.....
191406	Tablearia	... cannot leave before the.....
191407	Tablearon	... is completed.
191408	Tableaux	... I (we) will see you on or about
191409	Tableros	... We must have dimensions, sketches, or drawings.
191410	Tabliers	... We require more detailed information with reference to.....
191411	Tabliha	... We are sending you additional information with reference to.....
191412	Tablon	... We last heard from you on the.....
191413	Tabloza	... Refer to our letter dated.....
191414	Taboas	... Refer to our telegram dated.....
191415	Taboinha	... We refer to your letter dated.....
191416	Tabolagem	... We refer to your telegram dated.....
191417	Taboleiro	... Have you received our order for.....
191418	Taboleta	... We have not received your order for.....
191419	Tabooed	... Please send necessary instructions.
191420	Taboriten	... Please send confirmation by letter.
191421	Tabouer	... We forward by steamer advertised to close on the.....
191422	Tabouret	... Can you forward by the.....
191423	Tabourine	... The Bill of Lading must be to the order of.....
191424	Tabraca	... The Bill of Lading must be sent to.....
191425	Tabrimon	... The Bill of Lading has already been sent to.....
191426	Tabual	... The Bill of Lading has not been received.
191427	Tabuda	... Delivery cannot be made until we have the Bill of Lading.
191428	Tabularize	... Have you received the Bill of Lading.
191429	Tabulating	... Insure to cover cost, freight and insurance.
191430	Tabulista	... Insure to cover all charges and risks if latter is possible.
191431	Taburno	... We accept your order for.....
191432	Tacahout	... We accept your order dated.....
191433	Tacamaca	{ We cannot accept your order on terms proposed, please refer to our offer.
191434	Tacca	... Forward as early as possible.
191435	Tachylite	... We accept your offer dated.....
191436	Tachypetes	... We can carry out your proposals at extra cost of £.....
191437	Tacitly	... " " " " without extra cost.
191438	Taciturn	... Details of conditions are sent by mail.

DIMENSIONS, &c.

191439	Tackduty	... The gauge (or span) is..... inches.
191440	Tackled	... The radius is..... feet.
191441	Tackling	... The height of lift is..... feet per minute.
191442	Tacksman	... The speed of lift is..... feet per minute.
191443	Tackspins	... The maximum load is..... cwt.
191444	Tactical	... The average load is..... cwt.
191445	Tadorna	... The machine must take in..... inches.
191446	Tadpoles	... The output per hour is.....
191447	Taffata	... The effective horse power is.....

EXAMPLES OF CODE TELEGRAMS.

The following exchange of Telegrams shows the mode in which the Code is used :—

A correspondent telegraphs “**Taainagel dactilico 170 tabakreibe but admit 16 feet**” which, on reference to the Code means “Telegraph at what price packed and delivered f.o.b. English port you can supply and ship the following, viz. : double geared lathe 14 in. centres, to turn diameter of 4 ft. 6 in. to slide surface and screw cut (listed at £170) same as you last supplied but to admit 16 ft.”

Our telegram was “**Tabiquies 170 tabicamos**” which reads “Replying to your telegram our price is £170, we can deliver in four weeks.”

The reply to this was “**Taartkoek dactilico**” which translates, “Please supply and ship as soon as possible the following goods engaging freight and insurance free of particular average, double geared lathe to slide surface and screw cut self-acting and to admit 16 ft. between centres.”

THE A1 TELEGRAPHIC CODE.

The Code words pages i. to xi. conflict, to some extent, with those in the widely used A1 Code, but no confusion can arise if the latter is used *exclusively*, the subjoined (or other agreed) words being employed to clearly identify the Section of the Handbook referred to, thus :—

APPLEBY'S HANDBOOK OF MACHINERY, SECTION	I.	Admugitum
” ” ” ”	II.	Adnatobat
” ” ” ”	III.	Adociria
” ” ” ”	IV.	Adoliridas
” ” ” ”	V.	Adumbrato
” ” ” ”	VI., PART A.			Adonteremo
” ” ” ”	VI., PART B.			Adopertus
” ” ” ”	VII.	Adoptames

and the words in the Code which indicate, respectively, the number of page and line referred to, the dimensions of the machine, &c.

Example.—A correspondent who wishes to have a band sawing machine with adjustable table, &c., as illustrated and described at page 110 of this Section—using the A1 Code as above indicated and the Code word for the Section—cables : “**Feriato Trastienda Trastoamos Estupido Adoliridas.**”

On reference to the A1 Code this message will be found to mean : “Forward as soon as possible a band sawing machine as described in Appleby's Handbook of Machinery, Section IV., page 110, line 35, with saw pulley 36 inches diameter.”

CONTENTS

AND CODE WORDS FOR USE IN CONJUNCTION WITH APPELBY'S
COPYRIGHT TELEGRAPHIC CODE.

	CODE NO.	CODE WORD	PAGE
Accumulators	050375	<i>Daabite</i>	76
Acid, Muriatic, Price of	152
Adjustable Bearings for Shafting	050376	<i>Daadzaak</i>	136
Adjustable Pipe Cutters and Tongs	050377	<i>Daagde</i>	126—128
Air Propellers, Ventilation, Mining, &c.	050378	<i>Daagjes</i>	160
Angle Iron and Bar Bending Machines	050379	<i>Daagsch</i>	69
Anvils, Swages, Tongs, &c.	050380	<i>Daaldertje</i>	164, 165
Asbestos Sheet, Price of	152
Asbestos Washers, Price of	152
Augers and Brace Bits	050381	<i>Daaraan</i>	151
Axle Turning Lathe, Duplex	050382	<i>Daarachter</i>	27
Babbitt's Metal, Price of	152
Balata and Gutta Percha Belting	050383	<i>Daarbij</i>	145
Baling Hoop Punching and Shearing Machine	050384	<i>Daarbinnen</i>	130, 131
Bar or Tube Straightening Machines	050385	<i>Daarboven</i>	90, 91
Bar and Tyre Bending Machines	050386	<i>Daarheen</i>	91
Band Sawing Machinery	050387	<i>Daarlans</i>	109, 110
Band Saw Brazing Furnace	050388	<i>Daarlaten</i>	119
Band Saw Sharpening Machine	050389	<i>Daarmede</i>	119
Band and Fret Saws	050390	<i>Daarom</i>	150
Bearings for Shafting	050391	<i>Daaronder</i>	134—137
Bell Chucks, Lathe	050392	<i>Daarover</i>	39
Belts, Driving	050393	<i>Daartegen</i>	144—146
Belt Fastening	050394	<i>Daaruit</i>	146
Bench Drilling Machines	050395	<i>Daarvoor</i>	56—58
Bending Machines	050396	<i>Daarzijn</i>	68, 69
Bevil and Spur Wheels	050397	<i>Dabats</i>	135
Bellows, Smith's	050398	<i>Dabamos</i>	163, 164
Bench Vices	050399	<i>Dabareh</i>	165, 166
Blacksmith's Tools	050400	<i>Dabblingly</i>	164, 165
Blowing and Exhaust Fans	050401	<i>Dabbuida</i>	159—161
Boiler End Turning Lathe	050402	<i>Dabchick</i>	37
Boiler Makers Hammers	050403	<i>Dabei</i>	125
Boiler Shell Drilling Machines	050404	<i>Dabeocia</i>	46—48
Bolt and Nut Turning Lathe	050405	<i>Dabereth</i>	35
Bolt and Nut Screwing Machine, fixed	050406	<i>Dablarum</i>	59, 60
Bolt and Nut Screwing Machine, portable	050407	<i>Dabunt</i>	97, 98
Bolt and Nut and Pipe Screwing Stocks and Dies	050408	<i>Dacarath</i>	120—122
Borax, Price of	152
Boring Machines	050409	<i>Dacelo</i>	43, 44, 119
Boring and Facing Machines	050410	<i>Dachfahne</i>	44
Boring and Facing Machines, portable	050411	<i>Dachgiebel</i>	44
Boring and Mortising Machines, wood	050412	<i>Dachgrat</i>	116—119
Box Nailing Machine	050413	<i>Dachhaken</i>	116
Braces	050414	<i>Dachholz</i>	132
Braces, Ratchet	05041a	<i>Dachhite</i>	128
Brace Bits and Augers	050415	<i>Dachhasten</i>	151
Brackets, Wall Boxes, Hangers, &c., for Shafting	050416	<i>Dachhehle</i>	134—137
Brass, Price of	152
Brass Wire, Prices of	152
Brass, Steel, and Iron Melting Furnaces	050417	<i>Dachloch</i>	153—159
Break Lathes	050418	<i>Dachluke</i>	23, 24
Breaking Down Frame, timber	050419	<i>Dachmarder</i>	105, 106
Buffing Machine	050420	<i>Dachpfanne</i>	94

	CODE NO	CODE WORD	PAGE
Calipers, Micrometer and Vernier	050421	<i>Dachrecht</i>	130
Capstan and Chasing Lathes	050422	<i>Dachreihe</i>	33, 34
Carpenters' and Joiners Tools	050423	<i>Dachrohr</i>	151, 152
Carriers, Lathe	050424	<i>Dachsaeule</i>	38
Cast Steel Hand Hammers and Chisels	050425	<i>Dachsbau</i>	124
Cast Steel Octagon, &c.. Prices of	050426	<i>Dachsbeil</i>	124
Cast Iron Spur and Bevil Wheels	050427	<i>Dachshaube</i>	135
Change Wheels, Lathe	050428	<i>Dachsims</i>	38
Chasing Lathes	050429	<i>Dachskohl</i>	32—34
Chasing, Sliding, and Ending Lathes ..	050430	<i>Dachsschaf</i>	35
Chisels, Engineers'	050431	<i>Dachstein</i>	124
Chucks, Four Jaw, Independent and Universal	050432	<i>Dachstube</i>	38, 39
Chucks, Bell	050433	<i>Dachstuhl</i>	39
Circular Saw Bench	050434	<i>Dachstute</i>	100—103
Circular Saws, Wood and Metal	050434	<i>Dacian</i>	149
Circular Saws, Spindles and Bearings ..	050435	<i>Dacianos</i>	103
Clutch Couplings, Collars, &c.	050436	<i>Daciorum</i>	134, 135
Clyburn Spanners	050437	<i>Dacicum</i>	128
Coils, Hydraulic Pipe	050438	<i>Daciscani</i>	83
Cold Iron Sawing Machines	050439	<i>Daciscanos</i>	88—90
Coloured Waste, Price of	050440	<i>Dacos</i>	152
Compound Slide Rests	050440	<i>Dacos</i>	37, 38
Construction of Workshops, Plans, &c. ..	050441	<i>Dacoits</i>	1—23
Continuous Feed Saw Bench	050441	<i>Dacoits</i>	100
Contractors' Repairing Shops	050441	<i>Dacoits</i>	18—23
Copper Wire, Prices of	050442	<i>Dacrigelo</i>	152
Copper Wire Gauze, Price of	050443	<i>Dacriolea</i>	152
Copper Sheet, Prices of	050444	<i>Dacrioleos</i>	152
Copper Soldering Bits, Price of	050445	<i>Dacriolina</i>	152
Cotton and Canvas Belting	050446	<i>Dacrioma</i>	149, 150
Cramps and Cramp Braces	050447	<i>Dacriopeas</i>	155
Crank Axle Turning Machine	050448	<i>Dacriopeo</i>	153—159
Cranes for Rivetting, Forging, and other Machines	050449	<i>Dacrydium</i>	42, 43
Cross Cutting and Circular Saw Benches ..	050450	<i>Dacryoides</i>	43
Cross Cut, Pit and Frame Saws	050451	<i>Dacryome</i>	112
Cupola Hoists, Ladles, &c.	050452	<i>Dactilada</i>	126—128
Cupolas, Melting and Furnaces	050453	<i>Dactilados</i>	152
Cutters, Milling	050454	<i>Dactili</i>	44
Cutters, for Spur, Worm, and Bevil Wheels	050455	<i>Dactili</i>	105—109
Cutters for Moulding and Planing, wood ..	050456	<i>Dactilicas</i>	33
Cutters and Wrenches, Pipe	050457	<i>Dactilico</i>	28—30
Cyanide of Potassium, Prices of	050458	<i>Dactilitis</i>	31
Cylinder Boring Machine, Portable	050459	<i>Dactilolide</i>	24—25
Deal and Timber Frames	050460	<i>Dactilorum</i>	35
Double Geared Capstan Lathes	050461	<i>Dactylicum</i>	45—58
Double Geared Lathes	050462	<i>Dactylidem</i>	56—58
Double Geared Screw Cutting Foot Lathe ..	050463	<i>Dactylon</i>	46, 47
Double and Treble Geared Surfacing Lathe..	050464	<i>Dactylis</i>	47, 48
Double Stud Cutting Lathe	050465	<i>Dactylists</i>	48
Drilling Machines	050466	<i>Dactylo</i>	45, 46
Drilling Machines, Bench and Hand Power	050467	<i>Dactylosa</i>	48—50
Drilling Machines, Boiler Shell	050468	<i>Dactylosis</i>	55, 56
Drilling Machines, Boiler Shell, Vertical ..	050469	<i>Dadaces</i>	53, 54
Drilling Machines, Boiler Shell, Duplex ..	050470	<i>Dadastana</i>	45
Drilling Machines, Multiple	050471	<i>Dadeggiare</i>	50—54
Drilling Machines, Radial, Independent ..	050472	<i>Dadeggiava</i>	132
Drilling Machines, Radial Wall	050473	<i>Dadeggio</i>	123, 124
Drilling Machines, Sensitive	050474	<i>Dadelboom</i>	144—146
Drilling Machines, Slot and Keyway	050475	<i>Dadelbosch</i>	137—144
Drilling Machines, Standard, Single and Double geared	050476	<i>Dadelbosch</i>	137—144
Drilling Pillars and Cramps	050477	<i>Dadelbosch</i>	137—144
Drills, Twist	050478	<i>Dadelbosch</i>	137—144
Driving Belts	050479	<i>Dadelbosch</i>	137—144
Driving Pulleys	050480	<i>Dadelbosch</i>	137—144

INDEX AND CODE.

VII.

	CODE NO.	CODE WORD	PAGE
Drop Hammers	050475	<i>Dadelijk</i>	83
Duplex Axle Turning Lathe	050476	<i>Dadelotie</i>	26, 27
Duplex Wheel Turning Lathe	050477	<i>Dadelpit</i>	25, 26
Duplex and Screw Punching Bears	050478	<i>Dadelprium</i>	130, 131
Electrically Driven Machine Tools	23
Emery, Price of	152
Emery Cloth, Price of	152
Emery Wheel Grinders	050479	<i>Dadelwijn</i>	92—96
Emery Wheel Discs	050480	<i>Dadiva</i>	95, 96
Engineering Works, General, Plans, &c.	2—10
Engineers' Stocks, Dies, &c.	050481	<i>Dadivosa</i>	120—122
Engineers' Stores	152
Erecting and Fitting Shops and Equipment	6—10
Exhaust and Blowing Fans	050482	<i>Dadivosos</i>	159, 160
Exhausters and Blowers, Root's	050483	<i>Dadora</i>	163, 161
External and Internal Gauges	050484	<i>Dadotto</i>	128, 129
Fans, Blowing and Exhaust	050485	<i>Dadoxylon</i>	159, 160
Fast and Loose Pulleys	050486	<i>Daduchorum</i>	139—143
Fastenings for Belts or Straps	050487	<i>Daduchos</i>	146
Files and Rasps	050488	<i>Daduchum</i>	146—148
Fitting and Erecting Shops, Plans, &c.	6—10
Flanging Machines	050489	<i>Dadurch</i>	73—83
Flanging Presses, Hydraulic	050490	<i>Daedalici</i>	82
Fly Wheels and Pulleys, Grooved	050491	<i>Daedalicos</i>	143, 144
Foot Lathes	050492	<i>Daedalicum</i>	31, 32
Forge Cranes	050493	<i>Daedalion</i>	87
Forges and Blowers, Smiths' and Portable	050494	<i>Daedalis</i>	162—164
Forging Presses, Hydraulic	050495	<i>Dædalorum</i>	83
Foundry Hoists, Ladles, &c.	050496	<i>Daedalous</i>	155
Foundry Plant	050497	<i>Daemmerton</i>	153—162
Fret Saws	050498	<i>Daemmerung</i>	110, 150
Furnaces, Melting, Cupolas, &c.	050499	<i>Daemon</i>	153—159
General Joiner	050500	<i>Daemonicos</i>	113
Grinders, Slide Rests for	050501	<i>Daemonicum</i>	95
Grinding Machinery, Emery	050502	<i>Daemonis</i>	92—96
Grindstones and Troughs, Newcastle, &c.	050503	<i>Daemonum</i>	96, 97
Grooved Fly Wheels and Pulleys	050504	<i>Daempfen</i>	143, 144
Gas Tongs	05050a	<i>Daenipe</i>	127
Gauges, Internal and External	050505	<i>Daempfung</i>	128, 129
Gutta Percha and Balata Belting	050506	<i>Daenisch</i>	145
Hair Belting	050507	<i>Dæumling</i>	145
Hammers and Chisels	050508	<i>Daeva</i>	124, 125
Hammers, Steam, Pneumatic, and Drop	050509	<i>Dafnesagi</i>	85—88
Hand, Back and Lock Saws	050510	<i>Dafness</i>	150
Hand Feed Planing Machines	050511	<i>Dafner</i>	115
Hand Power Drilling Machines	050512	<i>Dagasira</i>	57, 58
Hand Rests, Lathe	050513	<i>Dagbericht</i>	37, 38
Hand Tools, Metal and Wood Working	050514	<i>Dagblinden</i>	120—133
Hangers, Wall Boxes, Brackets, &c.	050515	<i>Dagbloem</i>	134—137
Harbour Works Repairing Shops, Plans, &c.	10—18
Hauling Rope Pulleys	050516	<i>Dagbloemen</i>	140
Headstocks, Rests, &c., Lathe	050517	<i>Dagboek</i>	37, 38
Horizontal Boring Machines	050518	<i>Dagboeken</i>	44
Horizontal Sawing Machines	050519	<i>Dagboog</i>	103, 104
Hot Iron Sawing Machines	050520	<i>Dagdienst</i>	90
Hydraulic Machine Tools	050521	<i>Dagdiertje</i>	73—83
Hydraulic Accumulators, Pumps, &c.	050522	<i>Dagdieven</i>	74—76
Hydraulic Flanging Presses	050523	<i>Dagegen</i>	82
Hydraulic Flanging Presses, Cranes for	050524	<i>Dagelijks</i>	82, 83
Hydraulic Forging Presses	050525	<i>Dagental</i>	83
Hydraulic Mains, Coils and Fittings	050526	<i>Dageraad</i>	83

	CODE NO.	CODE WORD	PAGE
Hydraulic Plate Bending Machines	050527	<i>Daggebed</i>	83
Hydraulic Punching and Shearing Machines ..	050528	<i>Daggeldar</i>	83
Hydraulic Rivetting Machines	050529	<i>Daggers</i>	77—81
Hydraulic Forging Hammers	050530	<i>Daghinazzo</i>	83
Hydraulic Wheel Presses		<i>Daghwurder</i>	84
India Rubber Belting	050532	<i>Dagkwaal</i>	146
India Rubber Sheet, Price of	152
India Rubber Washers, Price of	152
Ingot Metal for Bearings, Price	152
Internal and External Gauges	050533	<i>Daglelie</i>	128, 129
Iron Sawing Machines, Cold and Hot	050534	<i>Daglicht</i>	88—90
Iron Wire, Prices of	152
Joiners' and Carpenters' Tools	050535	<i>Daglijden</i>	151, 152
Joiner, General	050534	<i>Daglijfate</i>	113
Keyway Cutting Machines	050536	<i>Daglijsten</i>	45
Laces, Leather and other Belt Fastenings ..	050537	<i>Daglooners</i>	146
Ladles, Foundry	050538	<i>Dagmar</i>	155
Lard Oil, Price of	152
Lathes, Metal Turning and Accessories	050539	<i>Dagmarsch</i>	23—38
Lathes, Wood Turning, Headstocks, &c. ..	050540	<i>Dagops</i>	117, 118
Lathes, Axle Turning, Duplex	050541	<i>Dagorder</i>	26, 27
Lathes, Boiler End Turning	050542	<i>Dagoussa</i>	37
Lathes, Bolt and Nut Turning	050543	<i>Dagoutan</i>	35
Lathes, Capstan	050544	<i>Dagreis</i>	33, 34
Lathes, Carriers for	050545	<i>Dagreizen</i>	38
Lathes, Change Wheels for	050546	<i>Dagronde</i>	38
Lathes, Chasing	050547	<i>Dagscholen</i>	32, 33
Lathes, Chasing, Sliding, and Ending	050548	<i>Dagschool</i>	35
Lathes, Chucks, Bell, Four Jawed, and Universal	050549	<i>Dagschot</i>	38, 39
Lathes, Double, Treble, and Single Geared..	050550	<i>Dagslaper</i>	25, 28—31
Lathes, Double Stud Cutting	050551	<i>Dagstar</i>	35
Lathes, Foot	050552	<i>Dagtoorts</i>	31, 32
Lathes, Parts of, Headstocks, Rests, Treadles, &c.	050553	<i>Daguerre</i>	118
Lathes, Pipe Joint Turning	050554	<i>Daguerrean</i>	35, 36
Lathes, Pulley and Wheel Turning	050555	<i>Daguil</i>	27, 28
Lathes, Railway Wheel, Duplex	050556	<i>Dagvaardan</i>	25, 26
Lathes, Roll Turning	050557	<i>Dagverhaal</i>	36
Lathes, Self Acting Break	050558	<i>Dagvlieg</i>	23—24
Lathes, Self Acting, Sliding, Surfacing & Screw cutting	050559	<i>Dagvliegen</i>	28—30
Lathes, Slide Rests for	050560	<i>Dagwacht</i>	38
Lathes, Stay and Stud Cutting	050561	<i>Dagwachten</i>	34
Lathes, Toolholders, Chucks, &c., for	050562	<i>Dagwerker</i>	38, 39
Lead Sheet, Prices of	152
Lead Wire	152
Leather and Link Belting (driving straps) ..	050563	<i>Dagwijzers</i>	144, 145
Leather, Best Hide, Price of	152
Lever Punching and Shearing Machinery ..	050564	<i>Dagnichtig</i>	130, 131
Linseed Oil, Price of	152
Locomotive Frame Plate Planing Machinery	050565	<i>Dagwaluw</i>	62
Log Frames	050566	<i>Dahabieh</i>	105—107
Machine Shops, Plans and Specification	6—10
Machine Tools	050567	<i>Daharum</i>	23—98
Magnolia Metal, Price of	152
Malleable Iron, Brass, &c., Melting Furnaces	050568	<i>Daher</i>	155—158
Melting Furnaces, Cupolas, &c.	050569	<i>Dahereilen</i>	153—159
Micrometer Callipers	050570	<i>Dahinleben</i>	130
Mill Saws	050571	<i>Dahinten</i>	149
Milling Machines	050572	<i>Dahlia</i>	40, 41
Milling Machines, Cutters for	050573	<i>Daignais</i>	42, 43
Model Makers' Lathes	050574	<i>Daignasses</i>	117, 118

INDEX AND CODE.

IX.

	CODE NO.	CODE WORD	PAGE
Mortising, Boring, &c., Machines	050575	<i>Daigneraiis</i>	116, 117
Moulding Machines and Cutters (Wood)	050576	<i>Daigneriez</i>	112
Muff and Clutch Couplings	050577	<i>Daikoku</i>	135
Multiple Drilling Machines	050578	<i>Daily</i>	45, 46
Muriatic Acid, Price of	152
Nailing Machines, Box	050579	<i>Daimachus</i>	116
Outside and Inside Gauges	050580	<i>Dainaca</i>	128, 129
Parallel Vices	050581	<i>Daintified</i>	166
Pattern Makers' Lathe	050582	<i>Daintify</i>	117, 118
Pedestals or Plummer Blocks	050583	<i>Daintiness</i>	134—137
Pendulum Circular Saws	050584	<i>Daintrel</i>	103
Perforated Rim Pulleys	050585	<i>Daiphantos</i>	143
Phosphor Bronze, Price of	152
Pillars and Cramps, Drilling	050586	<i>Daiphron</i>	132
Pipe Joint Turning Lathe... ..	050587	<i>Dairyhouse</i>	35, 36
Pipe Screwing Machines	050588	<i>Dairying</i>	97, 98
Pipe Screwing Stocks and Dies	050589	<i>Dairymaid</i>	120—122
Pipe Tongs	050590	<i>Dakbord</i>	127, 128
Pit, Cross Cut, Frame, &c., Saws	050591	<i>Dakborden</i>	149, 150
Planing Machines, Metal	050592	<i>Dakbordjes</i>	61—64
Planing Machines, Wood	050593	<i>Dakbos</i>	111—115
Planing Machines, Cutters	050594	<i>Dakdicht</i>	112
Planing and Moulding Machines	050595	<i>Dakdrop</i>	112
Planing and Squaring up Machines	050596	<i>Dakgoot</i>	111, 112
Planing and Thicknessing Machines	050597	<i>Dakhaak</i>	114
Planing and Trying up Machines	050598	<i>Daklatten</i>	112
Plate Bending Machines, Hydraulic	050599	<i>Dakleien</i>	83
Plate Bending and Straightening Rolls	050600	<i>Dakpijpen</i>	67—69
Plate Edge Planing Machines	050601	<i>Dakplat</i>	63
Plug and Ring Gauges	050602	<i>Dakrib</i>	129
Plummer Blocks or Pedestals	050603	<i>Dakribben</i>	134—137
Pneumatic and Steam Hammers	050604	<i>Dakriet</i>	85—88
Portable Boring Machine	050605	<i>Dakspar</i>	44
Portable Breaking Down Frames	050606	<i>Daksparren</i>	103—107
Portable Cranes for Rivetters	050607	<i>Dakstoel</i>	81
Portable Forges	050608	<i>Dakstoelen</i>	162, 163
Portable Hydraulic Rivetters	050609	<i>Dakvenster</i>	79, 80
Portable Screwing Machines	050610	<i>Dakwerken</i>	97, 98
Portable Vice Benches	050611	<i>Dalacenga</i>	165, 166
Potassium, Cyanide of, Price of	152
Presses, Hydraulic Flanging	05061a	<i>Daladote</i>	82
Pulleys, Perforated Rim, Rope Driving	050612	<i>Dalapax</i>	143, 144
Pulleys, Turned, Cast and Wrought Iron	050613	<i>Dalarnite</i>	137—144
Pulleys and Wheel Turning Lathe... ..	050614	<i>Dalarias</i>	27, 28
Pulleys, Wood	050615	<i>Dalbergia</i>	143
Pumps for Hydraulic Plant	050616	<i>Dalberwon:r</i>	74—76
Punching Bears, Screw and Duplex	050617	<i>Dalbic</i>	130, 131
Punching and Shearing Machines	050618	<i>Dalcanthe</i>	69—72
Punching and Shearing Machines, Hand Power	050619	<i>Daleau</i>	130, 131
Rack Saw Benches	050620	<i>Dalhousie</i>	99, 100
Radial Boring Machine, Wood	050621	<i>Dalibardie</i>	118, 119
Radial Drilling Machines	050622	<i>Dalippo</i>	48—50
Radial Drilling Machines, Wall	050623	<i>Dalivos</i>	55
Railway and Tramway Repairing Shops	10—20
Railway Wheel Lathe, Duplex	050624	<i>Daliumum</i>	25, 26
Ratchet Braces, Plug Ring and Step Gauges	050625	<i>Dallato</i>	128, 129
Red Lead, Price of	152
Repairing Shops, Plans, Specifications, &c...	10—20
Ripley Wrenches... ..	050626	<i>Dallieden</i>	128
Rivetting Plant, Hydraulic	050627	<i>Dalmacio</i>	73—83

	CODE NO.	CODE WORD	PAGE
Roller Feed Saw Benches	050628	<i>Dalmahoy</i>	100
Rolls, Plate Bending and Straightening	050629	<i>Dalmania</i>	67—69
Rolls, Turning Lathes	050630	<i>Da'matensi</i>	36
Root's Blowers and Exhausters	050631	<i>Dalmaticos</i>	160, 161
Rope Pulleys, Driving and Hauling	050632	<i>Dalmaticum</i>	140, 144
Rubber Belting	050633	<i>Dalmatique</i>	146
Saw Benches	050634	<i>Dalmium</i>	99—103
Saw Benches, Plain	050635	<i>Dalmif</i>	103
Saw Benches, Rising and Falling Spindle	050636	<i>Dalminfen</i>	101, 102
Saw Benches, Rising and Falling Table	050637	<i>Dalophide</i>	102
Saw Setting, Sharpening and Brazing Tools	050638	<i>Dalpade</i>	90, 119
Saw Spindles and Bearings, Circular	050639	<i>Dalphon</i>	103
Saws, Circular, Frame, Cross Cut, &c.	050640	<i>Daltoniano</i>	149, 150
Sawing Machines, Band	050641	<i>Daltonie</i>	109, 110
Sawing Machines, Horizontal	050642	<i>Daltonisme</i>	103, 104
Sawing Machines, Iron	050643	<i>Damaarde</i>	88—90
Screw Boss Pulleys	050644	<i>Damag</i>	137—142
Screw Cutting Foot Lathes	050645	<i>Damage</i>	31
Screw and Duplex Punching Bears	050646	<i>Damageable</i>	130, 131
Screwing Machines, Power Driven	050647	<i>Damagetus</i>	59, 60
Screwing Machines, Portable	050648	<i>Damaging</i>	97, 98
Screw Cutting Stocks and Dies	050649	<i>Damajavag</i>	120—122
Self Acting Break Lathe	050650	<i>Dama'io</i>	23, 24
Self Acting Lathes, All Motions	050651	<i>Damalionem</i>	28—30
Sensitive Drilling Machines	050652	<i>Damalionis</i>	53, 54
Shafting, Wrought Iron, Steel, and Accessories	050653	<i>Damals</i>	133—135
Shaping Machines	050654	<i>Damaretus</i>	65, 66
Shear Steel, Price of	124
Sheet Copper, Price of	152
Sheet Lead, Price of	152
Sheet Steel, Price of	124
Shearing and Punching Machines	050655	<i>Damasanio</i>	69—72
Shearing and Punching Machines, Lever	050656	<i>Damascado</i>	130, 131
Shrouded Wheels, Strengths of, &c.	135
Side Planing Machines	050657	<i>Damascammo</i>	63
Sledge and Hand Hammers	050658	<i>Damascando</i>	125
Slide Rests for Grinders	050659	<i>Damascarla</i>	95
Slide Rests for Lathes	050660	<i>Damascava</i>	37, 38
Slot Drilling Machines	050661	<i>Damascenos</i>	45
Slotting Machines	050662	<i>Damascenum</i>	66, 67
Smiths' Hammers, Tools, &c.	050663	<i>Damascino</i>	124, 125
Smiths' Hammers, Hydraulic	050664	<i>Damascius</i>	83
Smiths' Hearths and Blowers	050665	<i>Damascolla</i>	161—164
Smiths' Shops, Plans, &c.	5—22
Smiths' Tools	050666	<i>Damasippe</i>	164—166
Solder, Price of	152
Spanners	050667	<i>Damasippus</i>	128—133
Spelter, Price of	152
Split Pulleys	050668	<i>Damasiton</i>	137—140
Spring Steel, Prices of	124
Spur and Bevil Wheels	050669	<i>Damasked</i>	135
Spun Yarn, Price of	152
Standard Drilling Machines	050670	<i>Damasonion</i>	50—54
Stay and Stud Cutting Lathes	050671	<i>Damasquine</i>	34, 35
Steam, Pneumatic, &c., Hammers	050672	<i>Damassada</i>	85—87
Steam Tramway Repairing Shops	20
Steel for Engineers, Miners, &c.	050673	<i>Damassin</i>	124
Steel Forgings	050674	<i>Damast</i>	124
Steel Shafting and Accessories	050675	<i>Damastwerk</i>	133, 135
Steel Wire, Prices of	152
Step Plug and Ring Gauges	050676	<i>Dambezic</i>	129
Stocks and Dies	05067a	<i>Dambote</i>	120—122
Stores, Engineers, Prices of	152

	CODE NO.	CODE WORD	PAGE
Straightening Machine, Bar or Tube ...	050677	<i>Dambonite</i>	90, 91
Straightening and Bending Rolls ...	050678	<i>Dambord</i>	67—69
Straps, Driving, and Fasteners for ...	050679	<i>Damborden</i>	144—146
Surfacing Lathes ...	050680	<i>Damelope</i>	23—26
Surfacing Plates ...	050681	<i>Damenflor</i>	132, 133
Tallow, Price of	152
Tarred Yarn, Price of	152
Thickening and Planing Machines ...	050682	<i>Damengunst</i>	114
Timber and Deal Frames ...	050683	<i>Damenhut</i>	105—109
Tools, Blacksmiths' ...	050684	<i>Damenkleid</i>	164—166
Tool Grinders, Emery Wheel ...	050685	<i>Damenkopf</i>	92—95
Tool Holders, Lathe ...	050686	<i>Damenpferd</i>	38
Tools, Machine ...	050687	<i>Damenrock</i>	23—98
Tool Steel, Prices of	124
Tramway Repairing Shops	20
Travelling Hydraulic Rivetting Plant ...	050688	<i>Damenrolle</i>	80
Tube or Bar Straightening Machines ...	050689	<i>Damenschuh</i>	90, 91
Tube Expanders ...	050690	<i>Damenwelt</i>	125, 126
Tube Vices, Wrenches, and Cutters ...	050691	<i>Damerino</i>	126—128
Turned Shafting, Bearings, &c. ...	050692	<i>Damescoupe</i>	133—135
Turning Lathes, Metal ...	050693	<i>Damherfen</i>	24—37
Turning Lathes, Wood ...	050694	<i>Damhout</i>	117, 118
Turpentine, Price of	152
Twist Drills ...	050695	<i>Damhouten</i>	123, 124
Twist Drills, Grinders ...	050696	<i>Damianista</i>	94
Tyre Bending Machine ...	050697	<i>Damice</i>	91, 92
Tyre Drilling Machine ...	050698	<i>Damigella</i>	92
Universal Wood Working Machines ...	050699	<i>Damigian</i>	115, 116
Vernier Callipers ...	050700	<i>Damithales</i>	130
Vertical Boring Machine ...	050701	<i>Damiurgen</i>	43, 44
Vertical Side Planing Machine ...	050702	<i>Damiurgos</i>	63
Vices, Engineers, Smiths, &c. ...	050703	<i>Damiurgum</i>	165, 166
Wall Boxes, Brackets, Hangers, &c. ..	050704	<i>Damlooper</i>	134—137
Wall Drilling Machines ...	050705	<i>Dammarin</i>	54—56
Wall Planing Machines ...	050706	<i>Dammarique</i>	64
Washers, Asbestos, Price of	152
Washers, India Ruber, Price of	152
Waste, Coloured	152
Waste, Best White Cotton	152
Wheels, Spur and Bevil, Strengths of, &c.	135
Wheel Cutting and Dividing Machines ...	050707	<i>Dammbau</i>	42, 43
Wheel Cutting and Dividing Gear Cutters ...	050708	<i>Dammen</i>	43
Wheel Presses, Hydraulic ...	050709	<i>Dammefjes</i>	84
Wheel and Pulley Lathes ...	050710	<i>Dammmeise</i>	27, 28
White Cotton Waste, Prices of	152
White Lead, Prices of	152
Wire, Brass, Prices	152
Wire, Copper, Prices	152
Wire, Iron, Prices	152
Wire, Lead, Prices	152
Wire, Steel, Prices	152
Wood Split Pulleys ...	050711	<i>Dammularum</i>	143
Wood Turning Lathes ...	050712	<i>Dammulis</i>	117, 118
Woodworking Machinery	99—119
Workshop Construction, Plans, &c.	1—20
Wrenches, Pipe and Bolt ...	050713	<i>Dammweg</i>	126—128
Wrought Iron Pulleys ...	050714	<i>Dammweide</i>	140—142
Wrought Iron Shafting and Accessories ...	050715	<i>Dammable</i>	133—135
Yarn, Spun, Price of	152
Yarn, Tarred, Price of	152



SECTION IV.

MACHINE AND HAND
TOOLS.

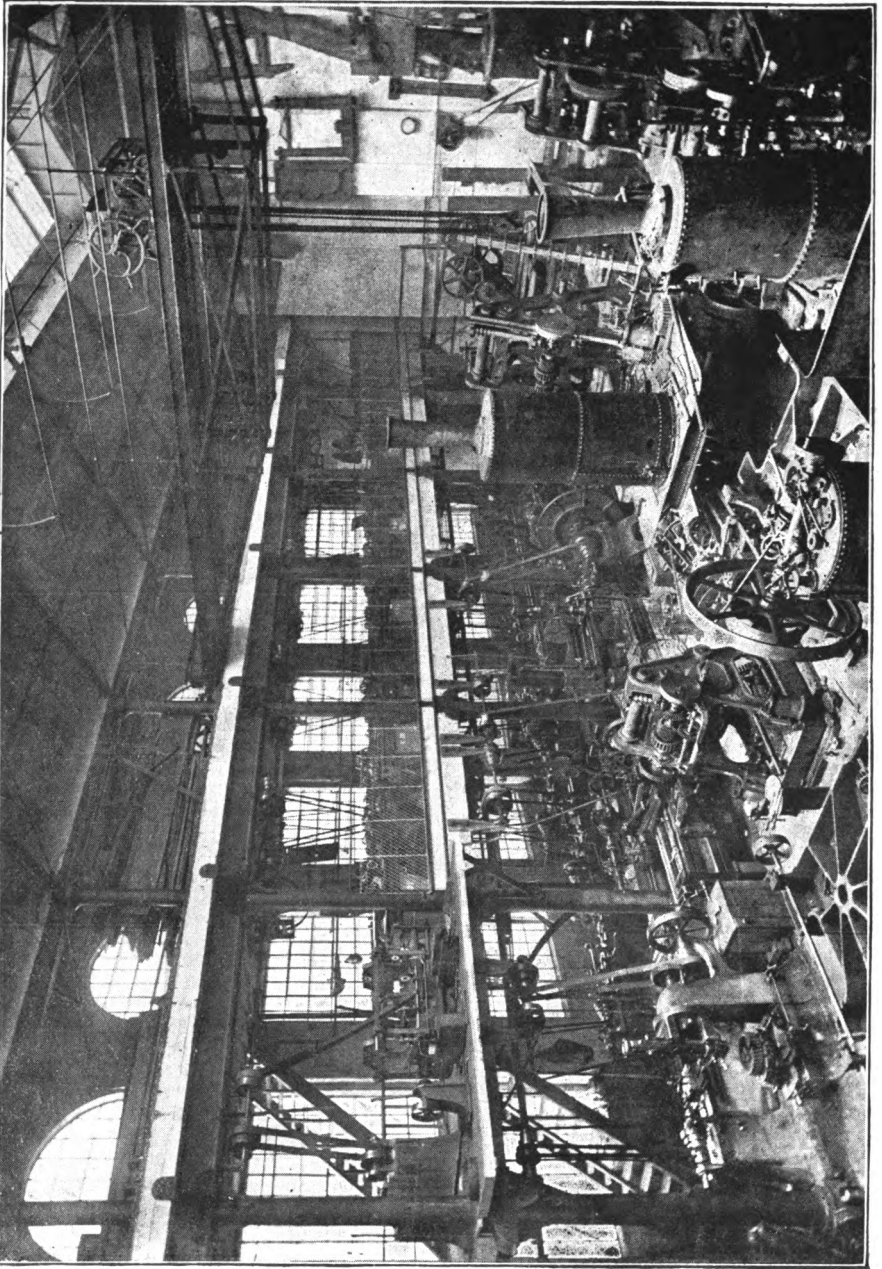

Fig 3000.

ENGINEERING WORKS AND MACHINE TOOLS.

It is difficult, perhaps almost impossible, for the young engineer to appreciate how greatly mechanical progress is indebted to the inventors of the varied appliances now known as machine tools; but undoubtedly the names of Mr. Richard Roberts, Mr. Maudesley, the Fairbairns, Mr. Nasmyth, Sir Joseph Whitworth, and many others will long be remembered as the pioneers in this branch of construction, which has played such an important part in attaining a precision in workmanship and a cost of production, unknown and undreamt of before the planing machine and the slide rest were invented.

Happily these inventors have many worthy followers, whose aim it has been and still is, constantly to improve in the production of tools for all kinds of work, from those used in the construction of ponderous marine engines down to the delicate mechanism of spinning, weaving, and sewing machines, and the still more delicate watchwork, electric appliances, &c.

To refer at all in detail to the American methods of tool construction, which are gradually becoming incorporated with English practice, or to the special tools in general use, would far exceed the limits available. It is therefore proposed for the most part to illustrate and describe only those machine tools commonly employed in the production of engineers' work, the examples being selected from those which have given good practical working results.

Before proceeding to describe the machines in detail, it may be well to consider some arrangements of the shops in which work may be economically executed.

WORKSHOP CONSTRUCTION necessarily involves consideration, firstly of the kind of work to be carried out, and of the quantity required in a given time; and secondly, of the local conditions, such as the space, and the kind of building materials available, the points from which raw materials can be received, and the finished work delivered, climate, lighting, etc.

The workshops illustrated (Figs. 3000 to 3014) were fitted up, and with one exception, were designed, by the Author's firm. It is not pretended that they are the best of their kind, but they have all answered the purpose for which they were designed, and they have been selected with a view to illustrate widely differing conditions, as regards the kind of work to be carried out, the building materials available, foundations, climate, etc., but in all cases the leading requirements have been:—

1. That with a view to economising time and labour the work shall go on progressively, and pass as far as possible from one department to another without backward movement of the material.

2. That proper provision shall be made for ample light, and for warmth in cold climates (See Figs. 3001 to 3005) and for coolness in hot; for the comfort of the work people unquestionably has a favourable influence both on the quantity and the quality of the work turned out.

3. Constant supervision with a limited staff.

4. Provision for increasing any department without interfering with the others.

Great economy is obtained by the judicious use of cranes and other lifting apparatus, but as these are described in detail elsewhere in this handbook, and will be referred to later on, it is only necessary here to indicate that they should enter into consideration in designing new works.

THE ENGINEERING WORKS (Figs. 3000 to 3003) afford an example of what can be done in a limited area, towards fulfilling the conditions above referred to. In this case the ground was covered with old buildings, which could under no circumstances have been used for engineering workshops, without great disregard to ultimate economy of space and cost of labour; there are, however, many cases where, with judicious arrangement, existing buildings can be advantageously used.

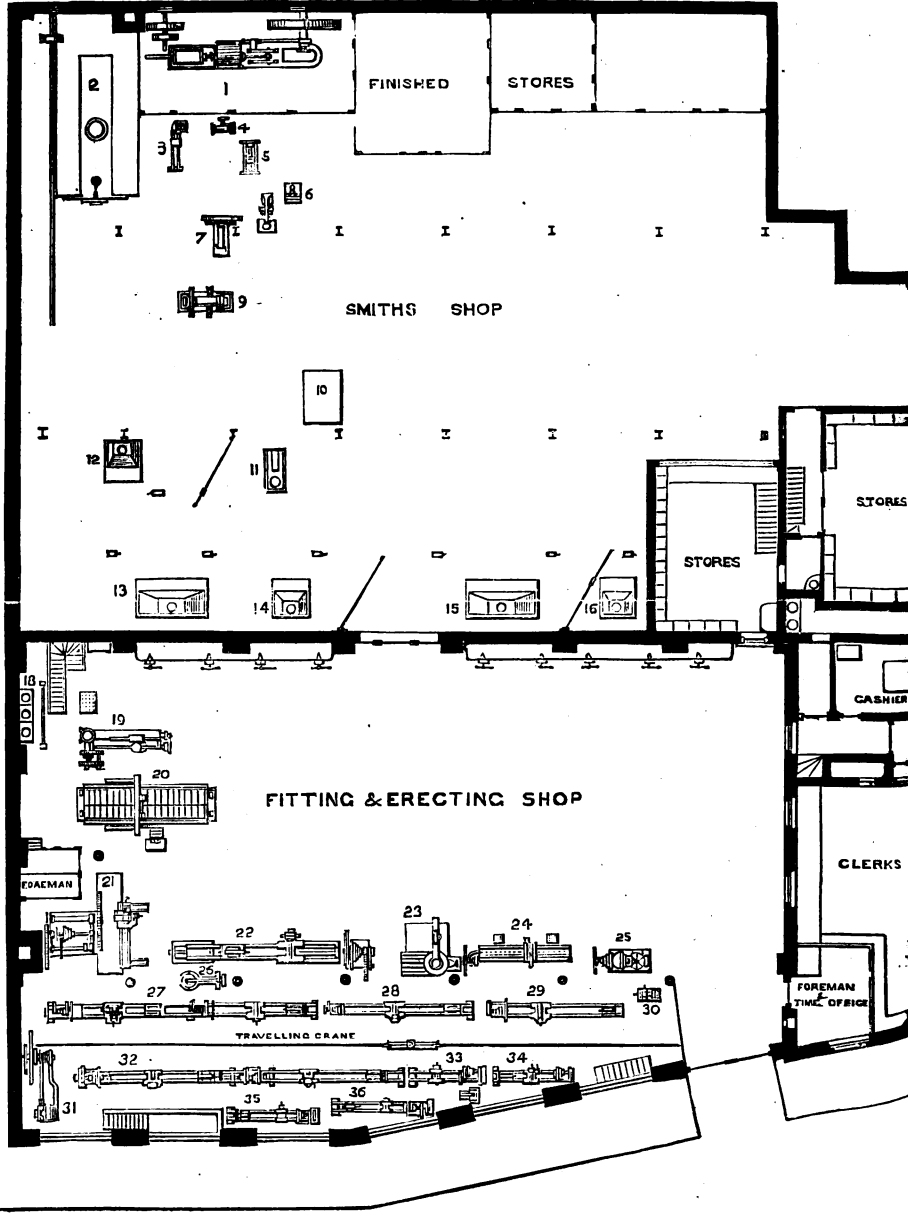
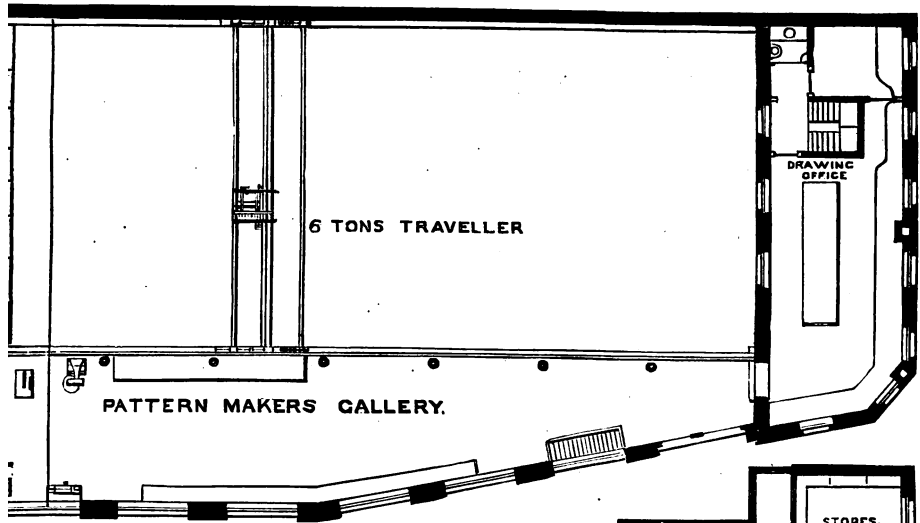

Fig. 3001.

Fig. 3003



SECOND FLOOR .

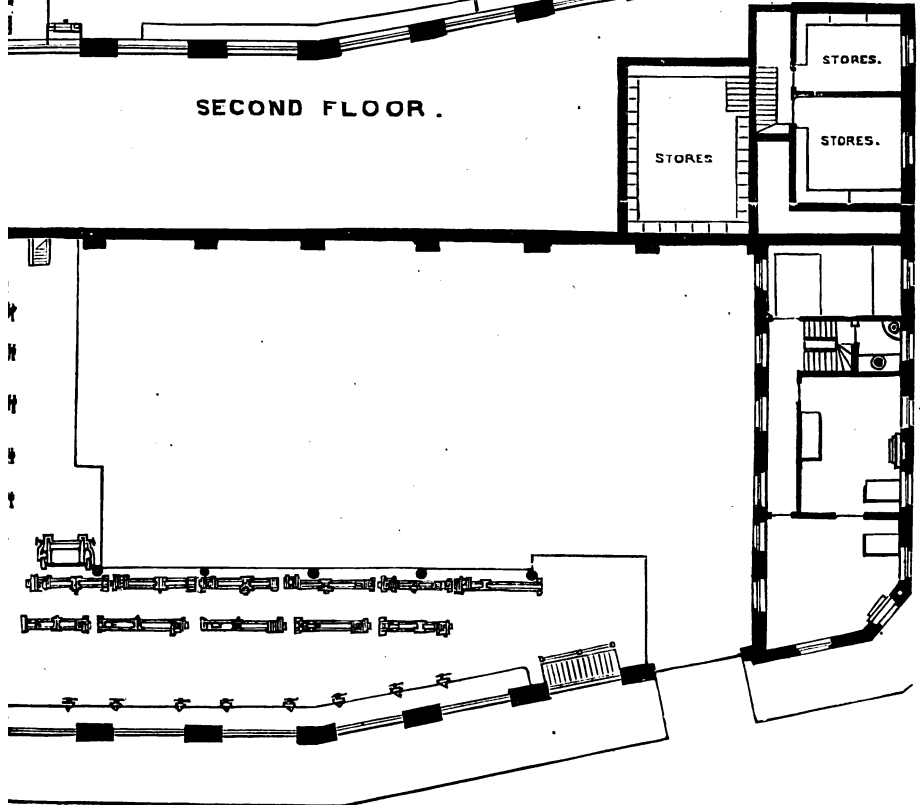

Fig. 3002.

These works (Figs. 3000 to 3003) were specially designed by the Authors for carrying out new inventions and experimental work, under the immediate supervision of the principals, for preparing drawings for other works in which the firm were interested, and for conducting a large export business.

For this purpose it was necessary to provide for a far larger staff of draughtsmen and clerks than would usually be required for works of these dimensions. In that respect the arrangements may be regarded as exceptional, but the shop is certainly adapted for producing engineers' work with as much economy as any of its size.

The works have a frontage to one street, where is the main entrance for goods and workmen. The office entrance is in another street, where is also a separate entrance to the smiths' shop, so that iron, coals, etc., may be received, or finished work delivered, without passing through the fitting department.

Fig. 3000 is a photographic view of the interior of the machine and erecting shops.

Fig. 3001 is a ground plan of the smith and boiler shop, turning, fitting, and erecting shops, and of the offices and stores.

Fig. 3002 is a plan of the lower or first gallery, and of the first floor offices.

Fig. 3003 is a plan of the second gallery and of the second floor offices, which are used as a drawing office, and from which a door gives access to the pattern makers' shop.

SMITHS' SHOP.—There is no floor over any part of this shop, and it is provided with an overhead travelling crane of 10 tons power and, for all ordinary loads, is worked by one man.

The whole of the machines are driven by a horizontal condensing engine (No. 1 on plan) with variable expansion gear worked from the governor; the air pump is behind the cylinder, and is worked by an extension of the piston rod, as indicated in Fig. 3001, page 3.

Owing to the limited supply of water obtainable from a shallow well on the premises, the only form of condenser that could be used, was the "Evaporative Surface Condenser," illustrated by Fig. 1538, Sec. 1, this is fixed on the roof and the condensing water is returned to the well. The exhaust steam passes from the cylinder to a water heater and thence to the condenser. The feed water drawn from the hot well is forced through the heater and enters the boiler at a temperature of about 180°. The water is highly charged with lime, some of which being deposited in the heater, saves the boiler to that extent, and the feed water entering the boiler at a high temperature, the results obtained are very satisfactory.

The boiler is of the Lancashire type as shown in Section I, with the usual combustion chamber and cross water tubes (No. 2 on plan).

From frequent indicator diagrams taken when the tools have been in their usual full work, the duty performed is about 23 to 25 horse power, and as the tools are driven with great regularity and economy, this data may be useful when estimating the power which should be provided when laying out new works.

The tools in this shop consist of—

- No. 3. Screwing machine.
- No. 4. Grindstone.
- No. 5. Emery wheels.
- No. 6. Single geared drilling machine, Fig. 3050.
- No. 7. Double geared pillar drilling machine, Fig. 3048.
- No. 8. Punching and shearing machine, Fig. 3073.
- No. 9. Large punching machine and angle iron shears, Fig. 3072.
- No. 10. Flattening plate.
- No. 11. Five-cwt. steam hammer.
- Nos. 12 to 16. Smiths' hearths, three single and two double hearths or a total of seven hearths, exclusive of rivet fires.

The fan 36in. diameter, is placed in the corner near to the No. 13 forge, and driven by the main shaft and a counter-shaft.

The counter-shaft shown near to the chimney shaft drives a line of main shafting, carried against the wall, of 3" diameter, running at 100 revolutions per minute: it is shown broken off in the engraving, but it really extends to the front of the fitting and erecting shop. A short shaft driven by a pair of mitre wheels, and the counter-shaft above mentioned, serve to drive the tools, Nos. 3 to 9.

Most of the forges are fitted with the usual form of smiths' crane carried from the walls, a heavier crane being placed at No. 14 forge to serve the steam hammer, near which also a small furnace, not shown in the engraving, is placed.

MACHINE FITTING AND ERECTING SHOP.—The best idea of the general construction of this shop will be obtained from the photograph (Fig. 3000). The building is not quite rectangular, the front following the line of the street. The main roof is supported on the one side by the brick piers and party wall of the smiths' shop, and on the other by cast iron columns of a total height of about 35 ft., with all the brackets requisite for carrying the two galleries, traveller beams, etc. Directly over the columns is a valley gutter, and two of the columns form down rain water pipes, the others being heated by steam in winter; a good quantity of heat is thus obtained near to the tools, where it is most wanted.

The tools fixed on the ground floor of this shop are as follows—

- No. 19. 7ft. Radial drilling machine swinging on one of the columns.
- No. 20. Planing machine. Fig. 3063.
- No. 21. Face lathe, capable of boring and turning 20 ft. diameter.
- No. 22. Break lathe, Fig. 3015.
- No. 23. Radial drilling machine, Fig. 3047.
- No. 24. Shaping machine, two tables, 16 in. stroke, Fig. 3066.
- No. 25. Slotting machine, Fig. 3067.
- No. 26. Pillar drilling machine. Fig. 3050.
- No. 27. Double 12 in. lathe, with two pairs of heads, can be worked as one lathe, or two distinct lathes.
- No. 28. 12 in. screw cutting lathe, Fig. 3021.
- No. 29. 12 in. " " "
- No. 30. Slot drilling machine, Fig. 3042.
- No. 32. 12 in. Screw cutting lathe, two pairs of head.
- No. 33. 9 in. self-acting lathe, Fig. 3021.
- No. 34. 9 in. " " Fig. 3021.
- No. 35. 9 in. " " Fig. 3021.
- No. 36. 9 in. " " Fig. 3021.

Behind No. 35 is an emery wheel, Fig. 3097 for sharpening the lathe tools.

No. 31 is a horizontal steam engine of 8 horse power for driving this shop in case of need, and the steps shown in the engraving against the front wall lead down to a stoke hole for a small Cornish boiler, placed in a vault under this part of the shop, the coal stores being in a vault under the pavement. This engine and boiler are only used to drive this shop for night work, during holiday times, or in case of repairs being required to the large engine, and have frequently been found most useful under these circumstances.

The fitters' benches and vices are fixed along the party wall between the brick piers, each man having a lock up drawer.

The centre of the floor, from the front of the fitters' benches to the tools opposite is a space for the erection of machinery, and the whole of this area is commanded by a 6 ton hand power overhead travelling crane.

The traveller is used for serving the heaviest tools, Nos. 19 to 25, for handling machinery in course of erection, or for loading or unloading vans. which are brought directly under it, the first floor gallery being cut short over the gateway to give ample headroom.

A swing crane is fitted to the column between the planing machine, No. 20, and face lathe, No. 21, which lifts loads up to 2 tons, and thus often relieves the traveller.

Under the first gallery is a single rail crane similar to that illustrated (Fig 2279 Section 11) which will pick up anything from the traveller, and swing or travel with it, and thus command all the tools under the gallery, not reached by the traveller.

The assistant foreman's office is behind the face lathe, and the chief foreman's office against the entrance to the shop; the latter is also shared by the time and cost clerk, a window immediately against the wicket in the large door serving for the ticket and pay window. All hands employed in the works, having to pass in and out this way, are under his direct supervision, and a spring catch and appliances are provided, which enable him to give anyone admittance without leaving his seat. In this office are placed the whole of the gas valves, each part of the works having separate mains with by passes, also the water main cock, all of which are in the time clerk's charge. Two windows communicate with the general office.

A line of rails is laid down the centre of the erecting space for testing any machine on wheels, and there is a large erecting pit in the middle of the shop for convenience in erecting cranes on long posts, hydraulic presses, etc.

The first gallery (Fig. 3002) is reached by steps close to the entrance, and is devoted to light tools. There are eleven self-acting screw cutting lathes, of from 6 in. to 8 in. centres, one single speed drilling machine, three shaping machines, one wheel cutting machine, centring machine, and grindstone. Under the windows and against the end wall are fitters' benches and vices. Several of the small tools enumerated are not shown on this gallery plan.

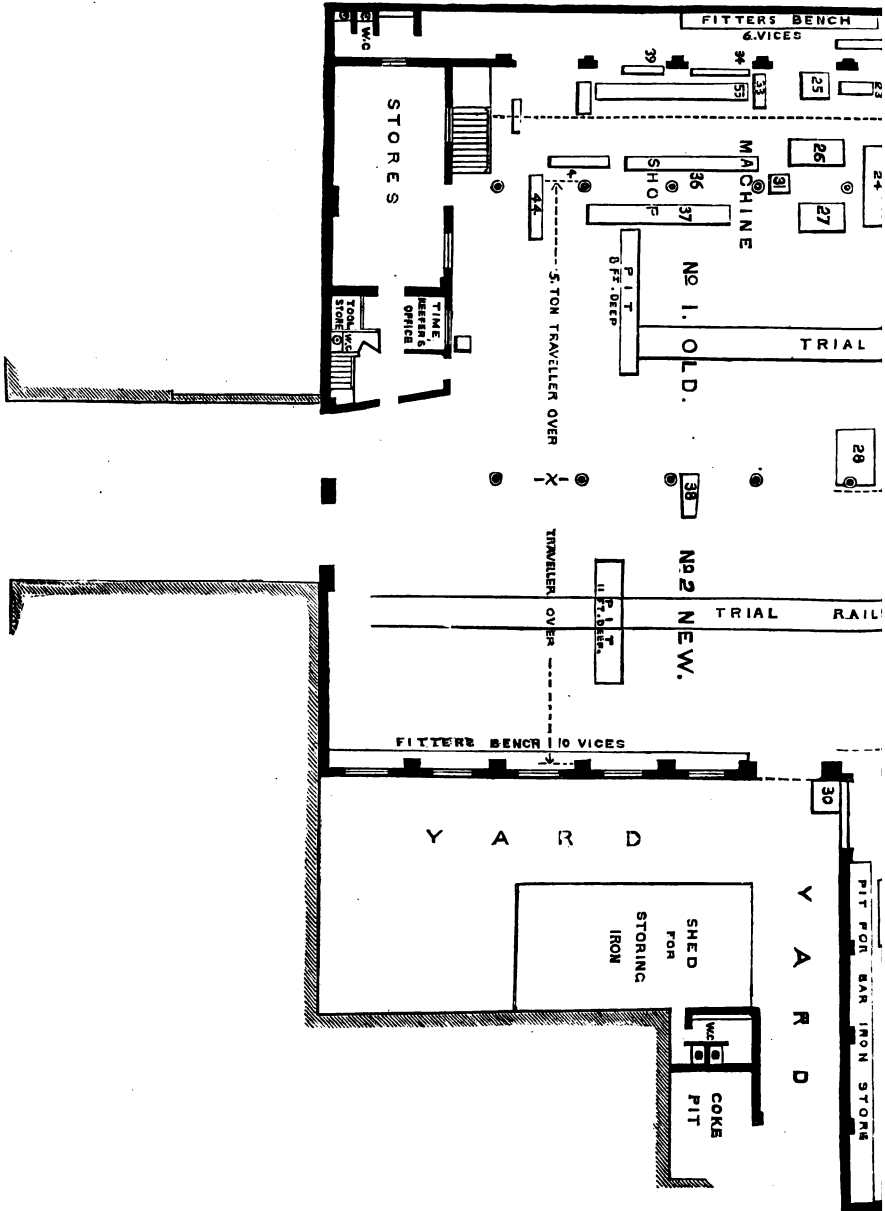

Fig. 3004.

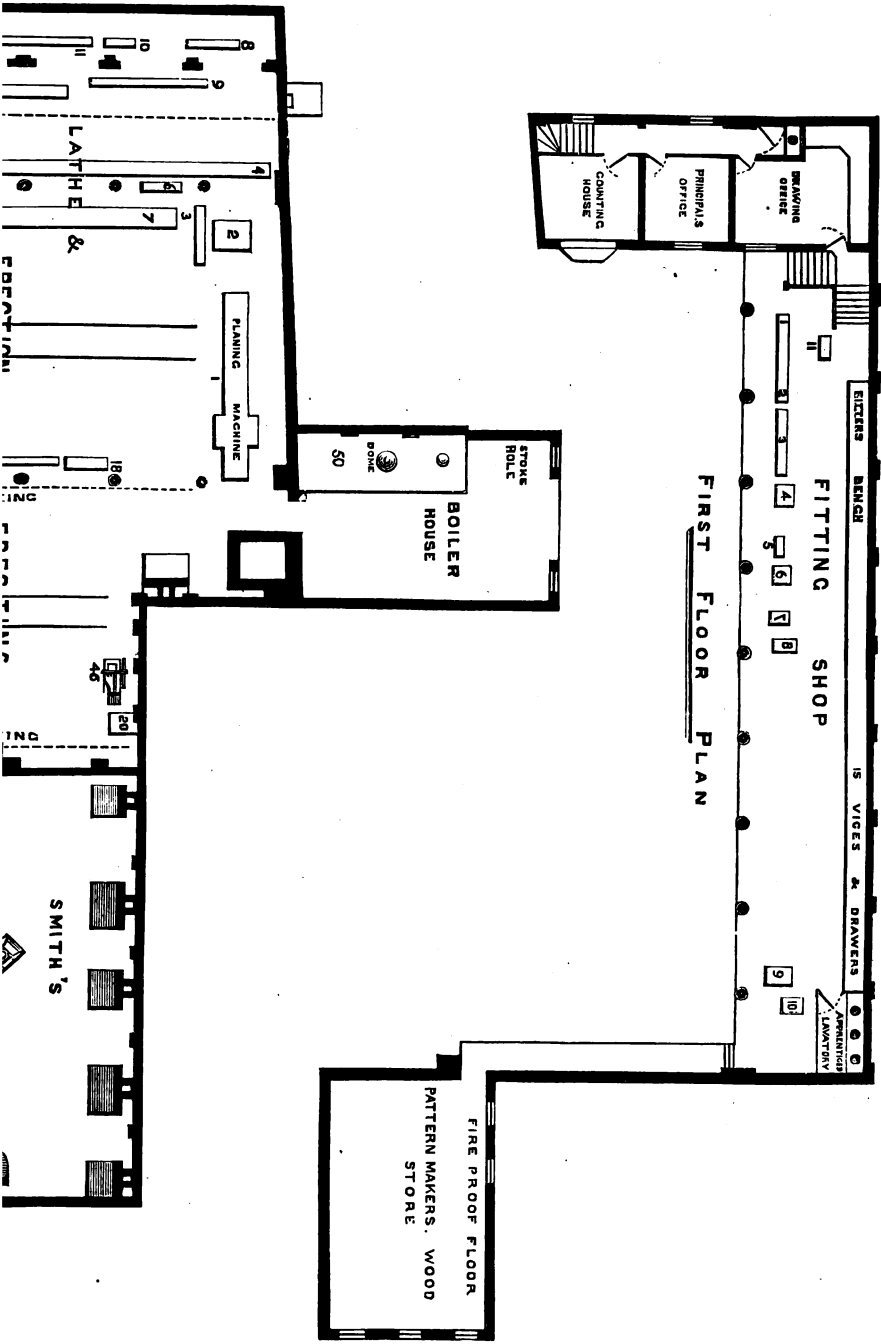

Fig. 3005.

The second gallery (Fig. 3003) is reached by steps from the first gallery as shown, and is used as a carpenters' and pattern makers' shop; there is accommodation for six pattern makers and two carpenters and packing case makers. At the end of this floor are placed, a small general joiner, a band saw, a pattern makers' single speed gap lathe, and a core print lathe. The cross gallery is fitted with pigeon holes for brass patterns, and at the office end of the main gallery is a door leading to the drawing office.

Both shops are lighted by sun lights; in addition to these each fitter and machine man has his own gas burner of a specially designed type, found to last much longer than those of the ordinary pattern.

Urinals and closets are provided on each gallery, as also on the ground floor, so that the men have not to leave their own department, and the drainage and ventilation of the works renders them comfortable and healthy.

The offices occupy the ground, first, and second floors, housekeeper's living rooms being provided on the third floor. On the ground floor is the main entrance, staircase, general offices, strong room, cashier's room, lavatory and closets; on the first floor, three rooms for principals and manager, waiting room, lavatory and closets; and on the second floor, large drawing office, chief draughtsman's office, lavatory and closet. It will be noticed that the whole of the offices on each floor have windows overlooking the works.

The works can accommodate about 150 workmen, and the cost of construction, exclusive of cost of land, was about £5,000; the value of the plant, stock, and stores may be taken at about £20,000. The windows are very large, 26 ft. in height, so that with the 10 ft. lantern along the roof, the lighting is as good as it can be, a condition very necessary in all shops, and especially those in large towns.

These may perhaps be considered good specimens of shops, having regard to cost of construction, and to facility in dealing with a large quantity of work in a limited area.

THE ENGINEERING WORKS (Figs. 3004 and 3005) are described by the "*Engineer*" as follows:—"The pattern making, fitting, smithing, and erecting departments are conveniently arranged in one building, so as to afford great facilities for the execution of work. The building, which is about 150 ft. long and about 90 ft. broad, is covered with a light iron roof, well lighted and ventilated. The erecting shop occupies the central part of this building 40 ft. in width, and extends nearly the whole length. From the columns, the roof is extended to the side walls; these portions of the roof are glazed to a width of about 9 ft., and extend throughout the whole length. The height from the floor line to the tie rods of the central portion of the roof is about 33 ft. On one side of the erecting shop, girders are thrown from the columns to the side wall, carrying the flooring of the fitting shop; a handrail is stretched between the columns. Under this species of platform is the machine department, some of the larger machines standing within the columns. On the other side of the building, without the columns, are arranged the smiths' forges and the steam hammer. The forges are disposed along the side wall, and the various flues are made to communicate with the chimney shaft, through one, which is common to the whole. Wood beams extend along the whole length of the erecting space on either side, resting on brackets cast on the columns. The girders are provided with suitable rails, on which a traveller is placed. The lower flanges of the traveller girders are about 22 ft. above the floor of the shop, giving space for any ordinary work beneath them. This traveller commands the whole space between the columns and is available for lifting heavy work to and from the large machines, and in lifting from the machines, the things can be at once placed in position for erection. The traveller is actuated by means of a cord, extending from a driving pulley situated at one end of the shop, and the lifting, lowering, and travelling motions are communicated by means of wedge and groove frictional gearing. The pattern shop is situated at one end of the building on a level with the fitting shop, where are also the stores and offices, the windows of the offices commanding a view of the whole building internally.

There are two commodious entrances to the works, one at either end; the proprietors have also procured possession of some adjoining property, and have made other provisions for further extensions. In the arrangements for facilities for executing work, the comfort of the workmen has not been forgotten. There is plenty of light and ventilation, and a very effective mode of warming is also adopted, which consists in turning steam into the hollow columns for a short time once or twice a day."

The extensions above referred to have been made since the article was written; the No. 2 new shop, the smiths' shop, and the pattern store having been added, without in any way interfering with the existing shops or with the work in progress in them.

No. 1 shop has a gallery running along one side as shown in Fig. 3004. The main entrance is at the east end of the works, and the doors are 11 ft. wide by about 18 ft. high, with a wicket door in them, the time keeper's and ticket office being close to this entrance. There are large gates at the west entrance for coals and timber, and on the south side for iron, smiths' coke, etc., so that none of these materials have to be brought in through the main entrance.

The smiths' shop is a separate building, and contains seven hearths, some of them double ones. A separate three storey building over the boiler house is used for the pattern stores. No. 1 shop is used principally for tools, the heaviest being under the command of No. 1 traveller.

The works are fully equipped with machine tools fixed in the positions indicated in Figs. 3004 and 3005, and the fitters' benches and vices are along the wall of the gallery, as well as on the ground floor against the outer walls; a number of portable vice benches for the use of erectors are moved about to suit the work in progress, providing in all for 50 fitters.

Erecting pits and lines of rails are provided in both shops; a 5 ton overhead travelling crane, worked by hand or driven by ropes, spans No. 1 shop, and a 10 ton traveller No. 2 shop. The traveller beams of No. 1 shop are carried on brackets cast on the columns, the centre line of columns having double brackets, so that the beams of No. 2 traveller can be carried by the brackets on one side of the columns, and on the outer wall on the other side. Each of the travellers has a clear lift of 25 ft.

The tools grouped on the left hand side of the shop are driven from a line of shafting, shown in the engraving by the dotted lines, and a vertical steam engine, specially designed, drives this shaft direct. The steam cylinder is 13 in. diameter by 24 in. stroke, and is fitted with automatic expansion gear; the shafting is 4½ in. diameter near the engine, reducing to 3 in. diameter farther on, and runs at 100 revolutions per minute.

The small engine, No. 46, is for driving the fan, and the two lengths of shafting shown in dotted lines; the left hand shaft drives the tools No. 18, 19, and 28, and the right hand shaft, the fan, No. 20, the small punching machine, No. 49, and the drilling machine, No. 21.

The tools in the gallery are driven from a countershaft fixed to the columns, the power being transmitted by a belt from the main shaft under the gallery floor. Countershafts for the heavy machine tools are carried from the front of the gallery floor in J hangers of a uniform pattern.

The shop stores and the time keeper's office adjoin, and are under the general offices; there are workmen's closets and urinals at the back of the stores, and others in the yard near to the coke and iron stores.

The offices are on the first floor over the stores, and comprise general office, principal's room and drawing office, the latter with a door leading to the gallery. The pattern makers' shop is over the offices, and near the drawing office. The whole of the windows on the first floor command an uninterrupted view of both shops and the gallery floor.

This arrangement of shops was found to be so satisfactory, that the same general design has been subsequently adopted, modified only to a sufficient extent to suit the exigencies of the site, difference in the class of work, accommodation required for offices, etc. The roofs in both cases were of the construction shown in Fig. 3000.

THE BATAVIA HARBOUR REPAIRING SHOPS at Tandjong Priok, illustrated by Figs. 3006 to 3009, were designed by the Author, and constructed and equipped by his firm under contract with the Government of Netherlands—India, and are described in some detail in the hope that information relating to these works may be useful when arrangements are under consideration for others—similar in character although not necessarily on so large a scale as these are.

A quantity of machinery, such as dredgers, locomotives and rolling stock, engines and boilers, cranes, pile drivers, concrete mixers, &c. (most of which were supplied by the Author's firm) had to be maintained in efficient working order. There were no private or other works within hundreds of miles where even ordinary repairs could be made, and it was decided that permanent workshops should be completed before the bulk of the plant for Harbour construction was delivered, and that they should be used for repairs, &c., to vessels and for other work after the Docks had been completed. Under these circumstances there was no reason why the works should not be equipped with the tools, engineer's stores, and other appliances which would eventually be required, and the facilities thus afforded for the erection and maintenance of the machinery, and the utility of the shops since the Docks were opened, amply demonstrate the wisdom of the decision above referred to. Some additions have been made since the works were established—about 15 years ago—such as an iron foundry and extensions of the machine and fitting departments, all of which have been carried out without interfering with the progress of work, and it is satisfactory to state that they have sustained no material damage from earthquakes, or even from the disastrous eruption of Krakatan on the 27th August 1883.

THE BUILDINGS (excepting those shown in heavy lines, which represent brickwork) consist of cylindrical columns set in concrete with boarding between most of them; the roof principals are made of wrought-iron and are covered with corrugated galvanized iron. The various parts were carefully marked for re-erection, and the shops were put up and ready for work in a remarkably short time after the materials had been delivered.

Fig. 3008

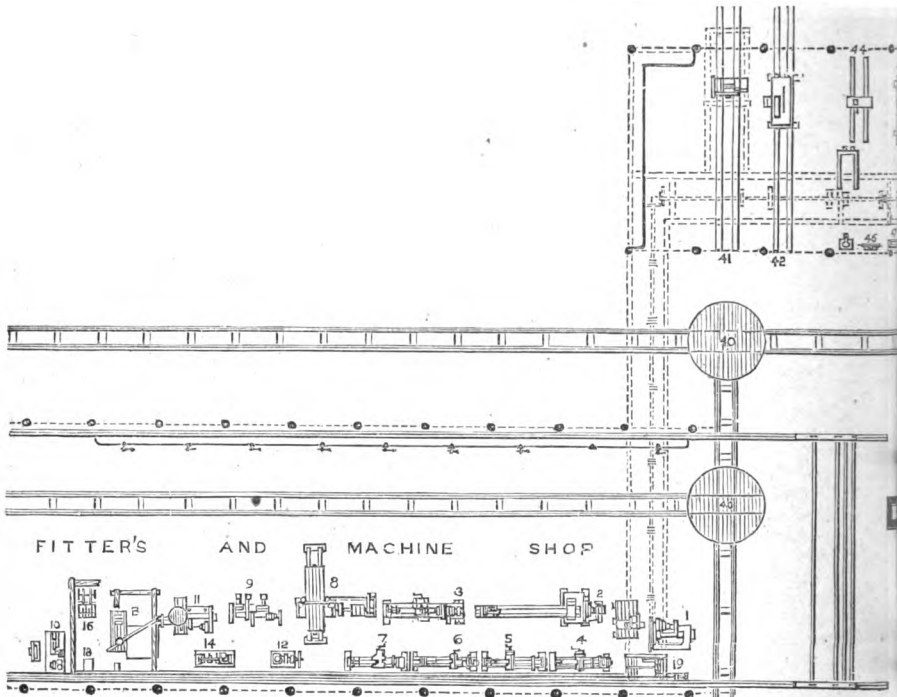
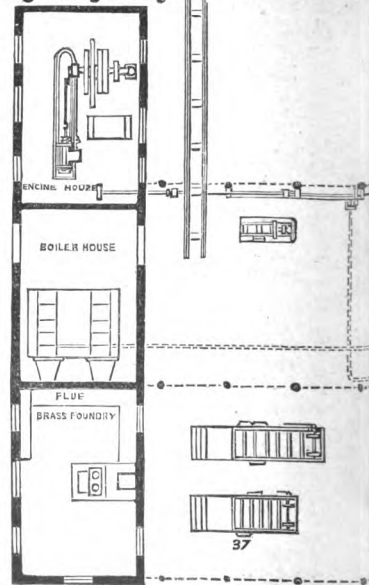

Fig. 3007



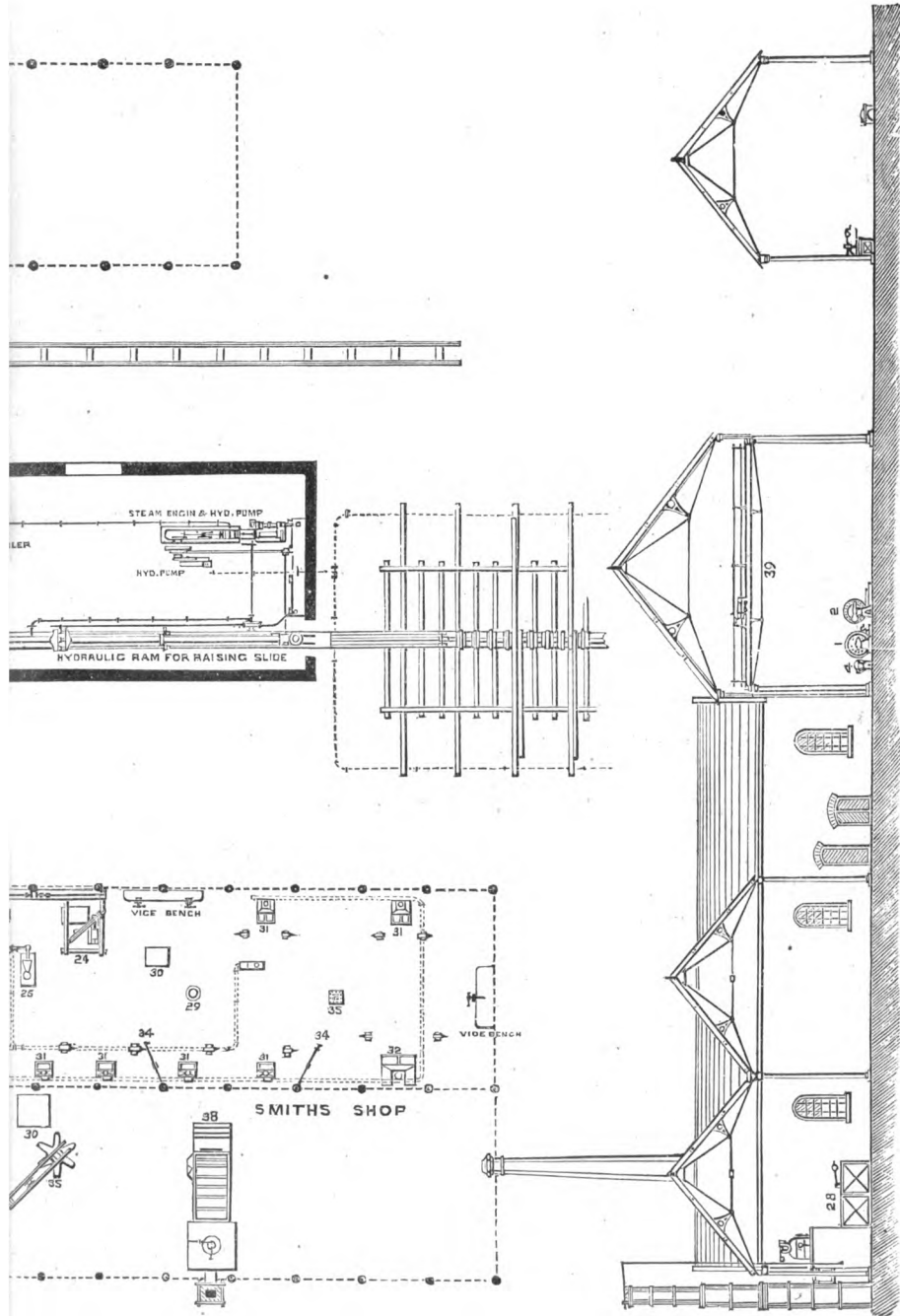

Fig. 3009

Fig. 3006.

THE SLIPWAY shown in the central part of the works was designed to have cast iron "ways" about 700 feet in length, secured to longitudinal sleepers bolted to cross sleepers, as shown. The proportions of the steam and hydraulic machinery, cradles with rollers and sliding bilge blocks, the links etc. were calculated for hauling vessels, up to about 1200 tons register, the whole of the machinery and metallic work being sent out, and the teak timber work for the cradles constructed at Batavia from drawings supplied by the Author.

The site was chosen with a view to convenience in making repairs, but after mature consideration and a closer examination of present and future conditions, it was decided to abandon the Slipway and to construct a temporary Floating Dock for use until the dry dock (not included in the original project) had been completed. As a consequence of this decision, the slipway was not made, and it is mentioned merely as a suggestion which may possibly be worth consideration in connection with works of a similar character if, for financial reasons, the large outlay for the construction of a dry dock cannot be entertained.

THE SMITHS' AND BOILER SHOPS shown in plan by Fig. 3006, and in section by Fig. 3009, are equipped with:—

- One 20 cwt. double acting steam hammer.
- One 10 cwt. " " "
- One 3½ cwt. " " "
- One Forge crane 17 ft. radius, with single and double purchase, to carry 30 cwt.
- One set of plate bending rolls to take in 8 ft.
- One punching and shearing machine to punch holes 1½-in. diameter in plates 1 in. thick at 15 in. from the edge. The angle iron shears cut 6 in. by ½-in. and any length, or round bars up to 2½-in. diam; the plate shears cut ¾-in. plate at 17in. from the edge.
- One punching and shearing machine to punch holes ¾-in. diameter in plates ½-in. thick at 8 in. from the edge, the shears at an angle for cutting bars any length, and two sets of spare tools for punching and shearing are provided.
- One set of ironwork for a plate furnace to take in plates 8 ft. by 4 ft. with counter-weighted rising door, dampers, all metallic work and fire bricks for building the furnace.
- Five single smiths' hearths, each complete, with 20 ft. of chimney, tuyere, water, trough, and bellows, also a connection with air main and valve to shut off pressure.
- Three double smiths' hearths as above.
- One circular smiths' hearth, and bricks, fire bricks, fire clay, &c., for setting each hearth.
- Twelve sets of smiths' tools consisting of—3 hand hammers (various), 1 flogging hammer, 1 flatter, 2 cold and 2 hot sates, 5 hot punches, 8 bolt tools, 2 fullers and 2 anvil fullers, 10 top and bottom swages (various), 2 sate hammers, 15 pairs of tongs (various), 2 hand punches, 2 snap tools, 2 drifts, 3 large steel rubbers, straight edge, steel square, steel rule, large and small callipers, hot and cold marking stamps and fire tools.
- Two cast iron swage blocks and stands
- Two smiths' cranes, with elevating screw, travelling jenny and sling, top and bottom carriages, with bolts for securing cranes to columns.
- One flattening plate.
- Two conical smiths' mandrils.
- One blowing fan, 30 inches, and 180 feet of air main with connection to each hearth.
- One radial drilling machine with arm 5 ft. 6 in. radius, to raise and lower 2 ft. by hand or power, with 12 in. range, of drill, and complete with 6 best cast steel drills, over-head motions, screw keys, &c
- Two small drilling machines, as Fig. 3057, to work by hand or power.
- One large best Newcastle grindstone, with wrought iron frame and trough.
- 110 ft. of bright steel shafting, with flanged couplings and turned bolts for same, and 10 pedestals, with hard gun metal adjustable bearings.
- Twelve turned driving pulleys, bored and key seated, driving belts suitable for each machine, with laces and fastenings.
- Two sets of boiler makers' tools, each to comprise—6 rivetters' hammers, 2 flogging hammers, 6 cold sates, 2 taper drifts, 6 caulking tools, 2 rod punches, 72 cotter bolts with cotters, 6 hand chisels, 2 pairs of rivet tongs, 6 snaps with rods, 12 boiler makers' cramps, 1 holding-up hammer, and 1 dolly.
- One tube expander, 2 in.

- One tube expander, 4 in.
- One trolley to carry 16 tons.
- One trolley to carry 10 tons.
- Two spare columns and two spare roof principals.
- One set of coppersmiths' tools, consisting of—2 coppersmiths' hammers, 2 large and 2 small planishing hammers, 2 pane hammers, 1 bottom and 1 side stake, 1 pair of shears, 1 pair of snips, 1 upright shank, 6 rivet sets, 1 beck iron, 1 long head, 2 round heads, 1 horse, 2 dozen dogs.

THE FITTING AND MACHINE SHOP (Figs. 3007 and 3009) are about 150 feet long and 46 feet wide and the traveller beams are carried over the yard, so that the crane (referred to further on) deposits anything up to about 10 tons weight in any part of the shop, in the yard, or on trucks, thus connecting the shops with the main and other lines. The equipment consists of:—

- One treble-gear surfacing lathe (1) as Fig. 3016, with face plate 10 feet diameter and a pit in front to admit large objects being bored and turned, moveable short bed with 1 grooves carrying a column and slide rest, and complete with 6 best cast steel tools, overhead motions, screw keys etc.
- One treble-gear break lathe (2) as Fig. 3015, with headstocks 16 in. centres, sliding bed 17 ft. long adjusted by screw, 1 grooved base plate for carrying pedestal and slide rest when surfacing large diameters, 6 cast steel tools, etc.
- One double geared sliding surfacing and screw cutting lathe (3) as fig. 3020, with headstocks 12 in. centres, bed 16 ft. long, back shaft for sliding, compound slide rest, leading screw, rack and pinion traverse, complete set of change wheels, universal chuck, face plate, catch plate, steady and following rests, 6 cast steel tools etc.
- Two double geared sliding, surfacing and screw cutting lathes (4 and 5) as Fig. 3021, with 9 in. centres and bed 12 ft. long, universal chuck, 6 steel tools etc. for each.
- Two lathes as above (6 and 7) but with 7 in. centres and beds 8 feet long.
- One planing machine (8) as Fig. 3063, with bed 12 feet long, quick return and self-acting reverse motion, to take in 4 ft. by 4 ft. and provided with two tool holders, self acting in the vertical, horizontal and angular motions, 6 steel tools etc.
- One shaping machine (9) as Fig. 3066, with stroke adjustable up to 16 in., quick return motion, bed 6 ft. long, two adjustable tables, and motions self acting in the horizontal and circular cuts, vice, expanding mandril, 6 steel tools, &c.
- One slotting machine (10) as Fig. 3067, to take in 4 ft. 6 in. diameter, stroke variable up to 16 in., quick return motion, with compound slide and circular tables for plain or curvilinear work, adjustable by power, 6 cast steel tools, &c.
- One slotting machine as above (16) but 6 in. stroke and to take in 2 ft. diameter, 6 steel tools, &c.
- One radial drilling machine (11) as Fig. 3047, with arm to swing through a radius of 5 ft. 6 in. and rise or fall 2 ft. by power, spindle $2\frac{1}{2}$ in. diameter, 12 in. range, feed motions, self acting or by hand, 6 steel tools, &c.
- One vertical drilling machine (12) as Fig. 3048, with spindle $2\frac{1}{2}$ in. diameter, and feed of 16 in., self acting or by hand, table adjustable by hand or power, boring bar to bore up to 12 in. diameter, drill chuck, 6 steel tools, &c.
- Two bench drilling machines as Fig. 3057, with spindle $1\frac{1}{2}$ in. diameter and 4 in. range adjustable table, and 6 steel tools, &c. for each.
- One bolt screwing machine (14) as Fig. 3062, to screw bolts or tap nuts from $\frac{3}{8}$ -in. upwards with all tools and accessories for renewing taps and dies.
- One wood screw cutting machine (19) to cut wood screws from $\frac{1}{2}$ -in. to $\frac{3}{4}$ -in. diameter.
- One pipe screwing machine for pipes up to 1 in. internal diameter.
- One " " " " " " " " 2 in. " "
- One best Newcastle grindstone, 4 ft. diameter, with wrought iron frame and trough, fast and loose pulleys, foot treadle, &c.
- The turned steel shafting, with flange couplings and bolts, wall boxes, bracket and other bearings, pulleys, belts, overhead motions, &c., for all the machines.
- Ten solid jaw fitters' vices, $6\frac{1}{2}$ in. to $7\frac{1}{2}$ in. wide.
- Ten sets of fitters' tools, each set comprising—1 cast steel hand hammer, 6 cast steel chisels, 4 cross cut and 4 pointed chisels, 3 key drifts and 1 caulking tool, steel screw keys for bolts $\frac{3}{8}$ -in. to $1\frac{1}{2}$ in., oil feeder, spirit level, plummet and line, centre punch, 2 pairs of callipers, 1 pair of compasses, 2 scribes, 1 steel rule, steel square, Lancashire hand vice, 4 erectors' cramps, copper hammer, wood hammer, and 2 surface plates.

Fig. 3010.

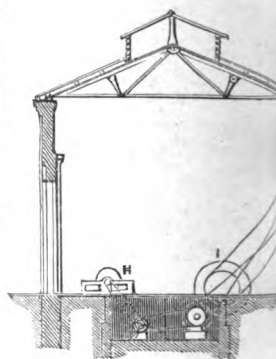
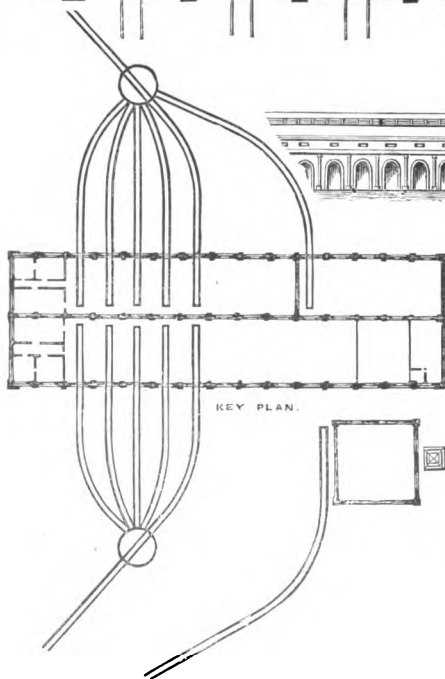
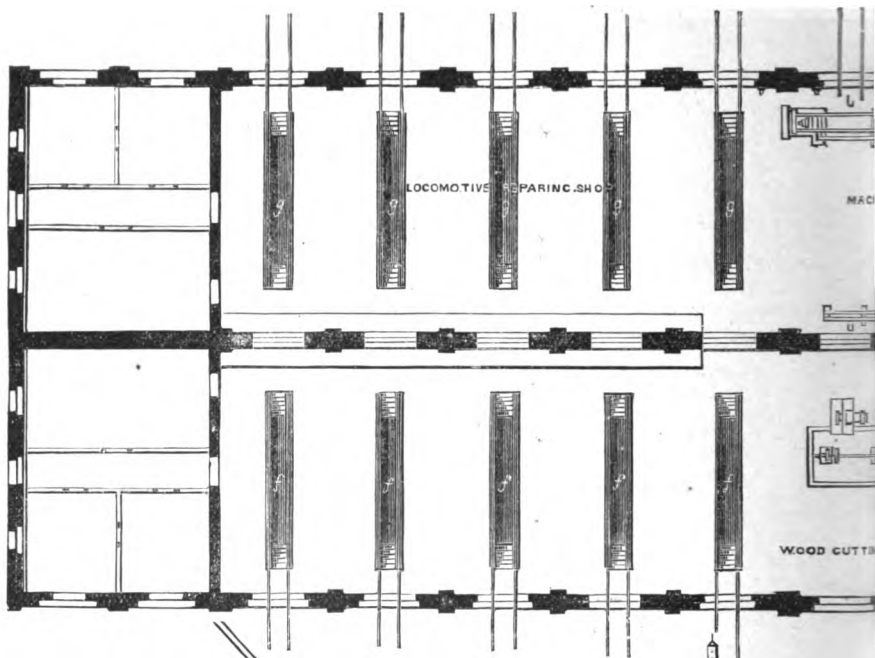

Fig. 3012.

Fig. 3011.

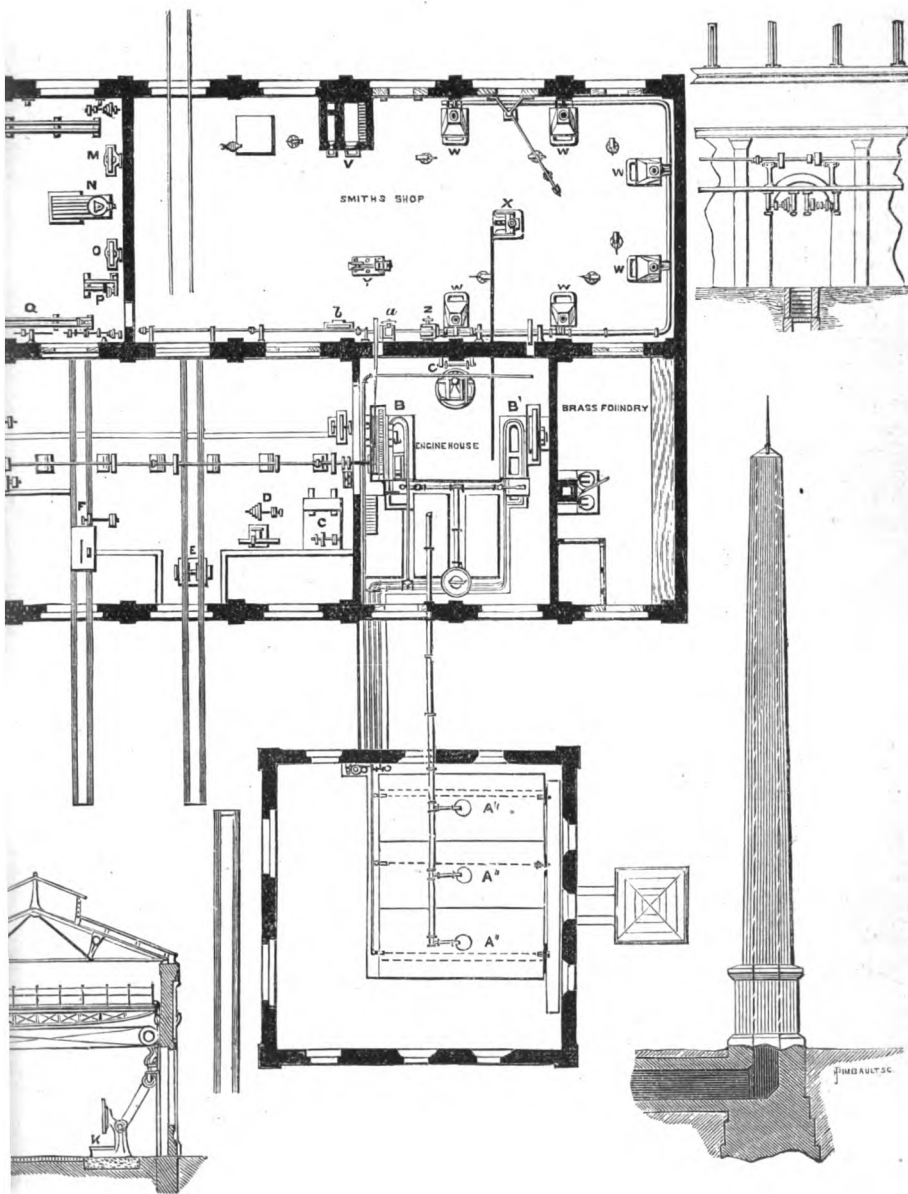

Fig. 3013.

One overhead travelling crane (39), as Fig. 3000, with wrought iron beams to span about 45 feet and carry a working load of 10 tons, the motions for lifting, traversing and travelling, or any combination of them, being worked from the crab.

Four shop trollies to carry 1 ton, with teak frame, wrought iron knees and bands, rings for hauling, &c., cast steel wheels, forged steel axles and open pedestal bearings.

Two spare columns, 2 roof principals, and 2 brackets for shafting.

THE ENGINE for driving the whole of the machinery is of the horizontal surface condensing type, with steam cylinder 20in. diameter by 30in. stroke, Meyer's expansion gear, air pump, circulating pump, fly wheel, two driving and one loose pulley, on the crank shaft.

A **FEED WATER HEATER** is placed between the steam cylinder and the surface condenser.

TWO MULTITUBULAR BOILERS fixed internally, tested to 8 atmospheres, provide an ample supply of steam for the engine, steam hammers etc., and are complete with all furnace, steam and feed water fittings and connections, fire brick settings etc.

THE CHIMNEY is of wrought iron, partially lined with fire-bricks, and fixed on a massive foundation plate. The section is square, and the chimney was sent out with stays, bolts, spare rivets, etc., ready for rivetting up and lining.

THE BRASS FOUNDRY equipment consisted of all the metallic parts, fire-bricks, etc., required, also an ample supply of melting pots, the metals being included in the "stores" referred to later on.

THE WOOD-WORKING AND CARPENTERS' SHOP Fig. 3008, is provided with the undermentioned machines:—

One log and deal frame, as Fig. 3119, to take in timber up to 20 in. in section, with fluted rollers, silent feed, carriages and all accessories for any feed up to 30 feet in length.

One circular saw bench as Fig. 3111, with table 8 ft. by 3 ft., and to take in saws of any diameter up to 48 in., adjustable parallel fence, lever and weight, draw up gear, rollers, carriages and rails for 50 feet traverse, complete with cast steel circular saws of 30 in., 36 in., 42 in. and 48 in. diameter.

One general joiner as Fig. 3125, for sawing tongueing, grooving, planing, cutting mouldings any size up to 7 in. by 3 in. and cross cutting, complete with saws 16 in. 20 in. and 24 in. diameter, 6 cutters for tongueing, 6 for grooving, 50 for planing and 50 for mouldings.

One boring and mortising machine to cut mortices 12 in. deep by 1½ in. wide, with 10 sets of tools for boring and morticing up to 1½ in.

One pile planing and grooving machine to finishing timber piles up to 12 in. wide, 8 in. thick, and 50 ft. long, with 12 pairs of cutter blocks and all accessories.

One saw sharpening machine to sharpen circular and frame saws and 6 spare emery wheels.

One gulletting machine for toothing circular frame and band saws, with spare tools for same.

Two grinding machines for sharpening moulding cutters, &c.

One circular saw vice.

The turned steel shafting (carried underground) with flange couplings and bolts, wall boxes, bearings, pulleys, belts, fastenings, &c., for driving all the machinery.

ENGINEERS' STORES.—As these could not be purchased in Java or obtained from Europe without a loss of time, which, in some cases, might be highly inconvenient, the Author advised that a supply of materials, in constant requisition, should be provided, and the undermentioned were included in the contract for the machinery and equipment of the works:—

One ton best cast tool steel, up to 2 in. square, assorted.

Half ton " " " " 2 in. round.

Half ton double shear steel.

Half ton chisel steel.

Twelve doz. 4 in three square bastard saw files.

Six doz. 6 in. " "

- Two doz. each, 12 in. and 14 in. flat bastard files.
 Three doz. each, 8 in., 10 in., 12 in., and 14 in. hand bastard files.
 Three doz. each, 8 in., 10 in. 12 in., and 14 in. half round ,,
 One doz. each 8 in., 10 in., 12 in., and 14 in. round ,,
 One doz. each, 8 in., 10 in., 12 in., and 14 in. square ,,
 One doz. 12 in. hand smooth files.
 One doz. 12 in. half round ,,
 Six doz. each $\frac{1}{2}$ -in. and $\frac{3}{8}$ -in. round and gulletting files.
 Three doz. 10 in. topping files.
 One doz. hand smooth files, each 6 in., 8 in., and 10 in.
 One doz. half round files, each 4 in., 6 in., 8 in., and 10 in.
 One doz. round bastard files, each 4 in. and 6 in.
 One doz. round smooth files, each 4 in., 6 in., 8 in., 10 in., and 12 in.
 Six doz. best cast steel fitters' hammers, $1\frac{1}{2}$ lbs. each.
 One cwt. steel wire, assorted.
 Five cwt. iron wire, assorted.
 Two cwt. half round iron wire, assorted.
 Half cwt. copper wire, assorted.
 One cwt. sheet copper to $\frac{1}{8}$ -in. thick.
 Two cwt. bar copper to $\frac{1}{2}$ -in. thick.
 Quarter cwt. copper rivets and bars assorted.
 One cwt. brass strips.
 Half cwt. gun metal sticks, $\frac{3}{8}$ -in. to 2 in.
 One cwt. fine spelter.
 Five cwt. sheet lead.
 Half cwt. patent metal.
 One cwt. solder.
 Half cwt. copper wire gauze.
 One cwt. sheet India rubber to $\frac{3}{8}$ in. thick.
 Quarter cwt. India rubber washers.
 Two hundred and fifty feet wrought iron gas pipe, each $\frac{3}{8}$ -in., $\frac{1}{2}$ -in., $\frac{3}{4}$ -in.,
 1 in., $1\frac{1}{2}$ in., $1\frac{1}{4}$ in., and 2 in. diameter.
 Twelve each bends, elbows, long screws, tees, backnuts, and nipples for each
 size.
 Two pipe tongs for each size.
 Bolts and Nuts as follows:—
 Half cwt. each $\frac{1}{2}$ -in. by $\frac{1}{2}$ -in., 1 in., $1\frac{1}{2}$ in., $1\frac{1}{2}$ in.
 Half cwt. each $\frac{3}{8}$ -in. by 1 in., $1\frac{1}{2}$ in., $1\frac{1}{2}$ in., 2 in., $2\frac{1}{2}$ in., and 3 in.
 One cwt. each $\frac{1}{2}$ -in. by $1\frac{1}{2}$ in., $1\frac{3}{4}$ in., 2 in., $2\frac{1}{2}$ in., $2\frac{1}{2}$ in., 3 in., $3\frac{1}{2}$ in., 4 in.,
 $4\frac{1}{2}$ in., 5 in., $5\frac{1}{2}$ in., and 6 in.
 Two cwt. each $\frac{3}{8}$ -in. by $1\frac{1}{2}$ in., $1\frac{3}{4}$ in., 2 in., $2\frac{1}{2}$ in., $2\frac{1}{2}$ in., 3 in., $3\frac{1}{2}$ in., 4 in.,
 $4\frac{1}{2}$ in., 5 in., $5\frac{1}{2}$ in., and 6 in.
 Two cwt. each $\frac{1}{2}$ -in. by 2 in., $2\frac{1}{2}$ in., $2\frac{1}{2}$ in., 3 in., $3\frac{1}{2}$ in., 4 in., $4\frac{1}{2}$ in., 5 in.,
 $5\frac{1}{2}$ in., 6 in., $6\frac{1}{2}$ in., and 7 in.
 One cwt. each $\frac{3}{4}$ -in. by 2 in., $2\frac{1}{2}$ in., $2\frac{1}{2}$ in., 3 in., $3\frac{1}{2}$ in., 4 in., $4\frac{1}{2}$ in., 5 in.,
 6 in., 7 in., 8 in.
 Five cwt. $\frac{1}{2}$ -in. by 1 in. bolt ends.
 Hexagon black nuts.
 One cwt. each $\frac{1}{2}$ -in., $\frac{3}{8}$ -in., $\frac{3}{4}$ -in., $\frac{7}{8}$ -in.
 Hexagon head set screws.
 One cwt. each $\frac{3}{8}$ -in. by 1 in., $1\frac{1}{2}$ in., $1\frac{1}{2}$ in., $1\frac{3}{4}$ in. and 2 in.
 Half cwt. each $\frac{1}{2}$ -in. by $1\frac{1}{2}$ in., $1\frac{3}{4}$ -in. and 2 in.
 Half cwt. each $\frac{3}{8}$ -in. 2 in., $2\frac{1}{2}$ in. and 3 in.
 Coach screws with self entering points.
 Half cwt. each $\frac{3}{8}$ -in. by 2 in., $2\frac{1}{2}$ in., 3 in., $3\frac{1}{2}$ in., 4 in.
 Half cwt. each $\frac{1}{2}$ -in. by do. do.
 Half cwt. each $\frac{3}{8}$ in. by do. do.
 One cwt. each $\frac{1}{2}$ -in. by 3 in., $3\frac{1}{2}$ in., 4 in., $4\frac{1}{2}$ in., 5 in. and 6 in.
 Ten cwt. iron washers assorted.
 Ten cwt. rivets assorted.
 Five cwt. wood screws assorted
 Four cwt. each 2 in., $2\frac{1}{2}$ in., and 3 in. cut clasp nails.
 One cwt. each $2\frac{1}{2}$ in., 3 in., and $3\frac{1}{2}$ in. cut floor brads.
 One cwt. each $1\frac{1}{2}$ in., 2 in., $2\frac{1}{2}$ in., 3 in. cut rose nails.
 Ten thousand each $\frac{3}{8}$ -in., $\frac{1}{2}$ -in., $\frac{3}{8}$ -in cut tacks.

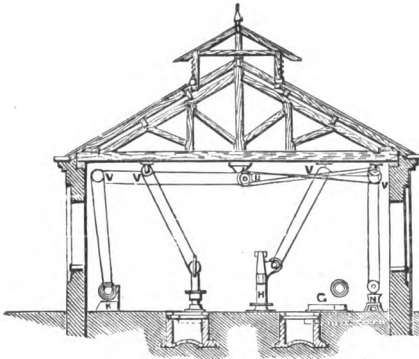
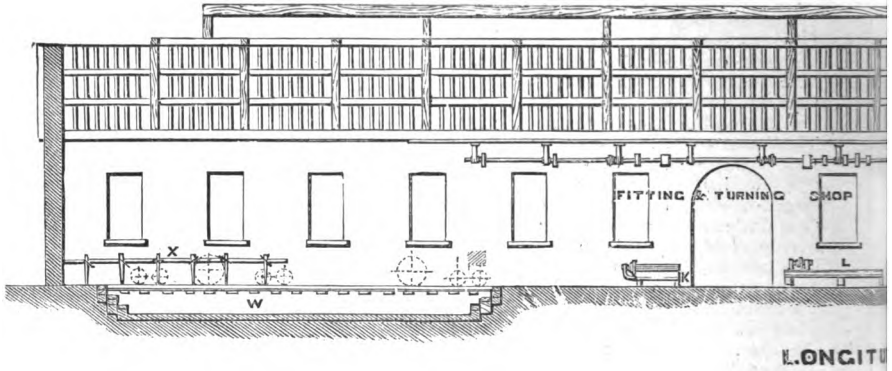

SECTION THROUGH LINE . A . B .

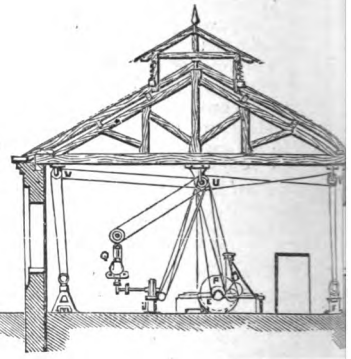

SECTION THROUGH LINE . C . D .

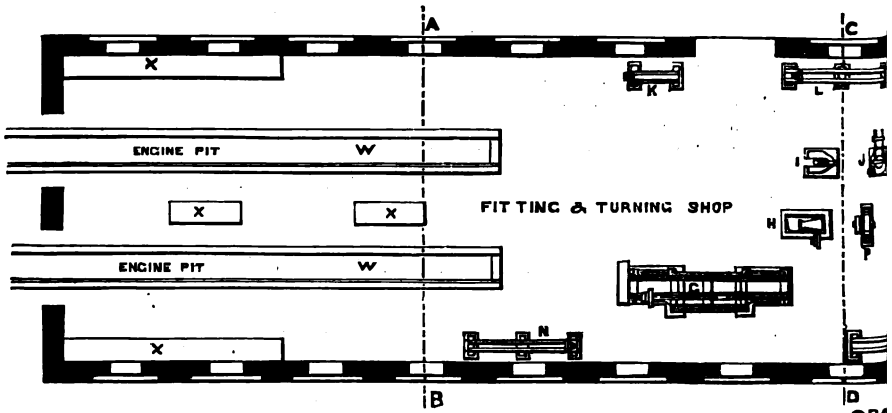
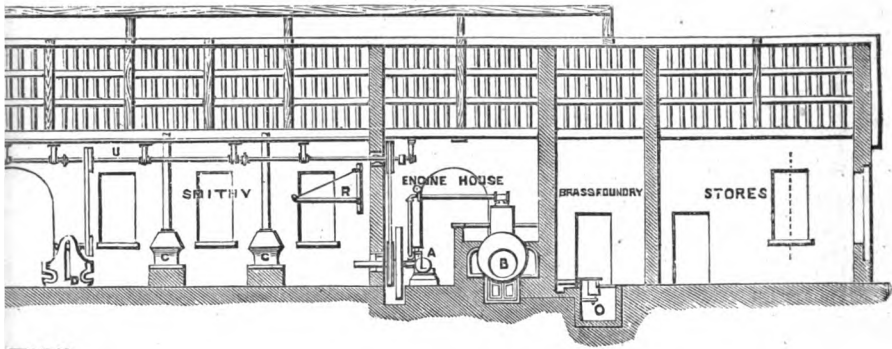
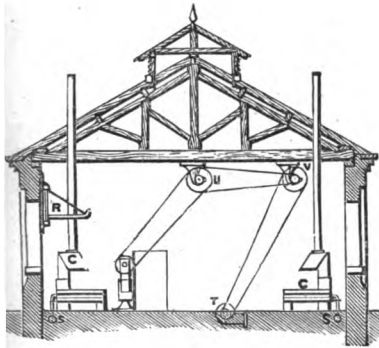

Fig.



SECTION .



SECTION THROUGH LINE. E.F.

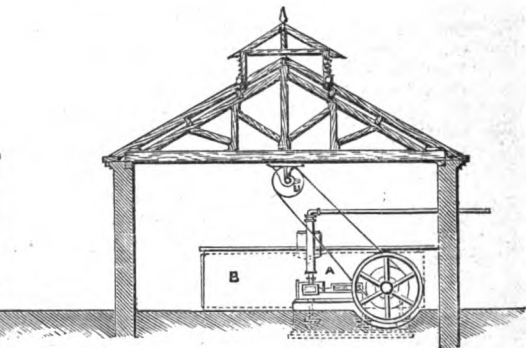

SECTION THROUGH LINE. G.H.

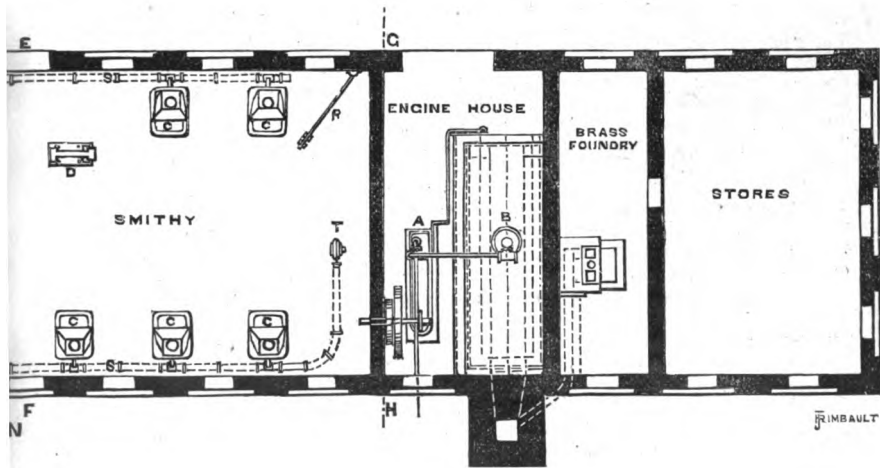

- Ten thousand each $\frac{3}{8}$ -in. and $\frac{1}{2}$ -in. cut tinned tacks.
 Ten thousand each $\frac{1}{2}$ -in., $\frac{3}{4}$ -in., 1 in., $1\frac{1}{2}$ in., $1\frac{1}{2}$ in., 2 in. Joiners' cut brads.
 Five cwt. white lead.
 Two cwt. red lead.
 Five cwt. tallow.
 Fifteen gallons best lard oil.
 Three cans for ditto.
 Ten gallons turps. and two cans.
 One gallon muriatic acid.
 Twenty-eight lbs. borax.
 Fourteen lbs. prussiate potash.
 Twenty-eight lbs. sal ammoniac.
 Fourteen lbs. sulphur.
 Five cwt. best coloured waste.
 Half cwt. spun yarn.
 Half cwt. tarred yarn.
 Half cwt. glue.
 Half cwt. best hydraulic leather.
 Three reams emery cloth.
 Six copper soldering bits.
 Three dozen half-pint oil cans.
 Three dozen one-pint ditto.
 One dozen half-gallon oil bottles.
 One dozen one-gallon ditto.
 One dozen each 2, 3, and 4 quart paint tins.
 Three dozen dusters, assorted.
 Three dozen ground brushes, assorted.
 Four dozen sash tools.
 Half dozen hand lamps.
 Twenty-eight lbs. cotton waste.
 One set Whitworth stocks and dies, complete with taper, second plug, master taps, and tap wrenches, $\frac{1}{2}$ -in. to 2 in.
 One set gas stocks and dies $\frac{1}{2}$ -in. to 2 in.
 Two cwt. wrought iron spanners.
 One Lancashire screw plate and taps to $\frac{1}{2}$ -in.
 One set Weston's pulley blocks, each 10 cwt., 1 ton and 2 tons with 40 feet of chain to each.
 One hydraulic jack, each 4, 8 and 20 tons.
 One ship's jack 100 tons.
 Three each 14 in. and 16 in. ratchet braces with 12 drills to each.
 Three wrought iron drill posts.
 Three each 12 in., 14 in., and 16 in. shifting spanners.
 One set patent pipe wrenches.
 Three dozen 14 in. metal webs.
 Three frames for ditto.
 One hundred-and-fifty feet each 3 in., 4 in., 5 in. and 6 in. leather belting.
 Six gross 3 feet laces. Six strap punches.
 Two cwt. resin. Six dozen 16 in. hammer shafts.
 Three doz. each 22 in. by 30 in. hammer shafts.
 Three doz. 3 ft. 6 in. sledge hammer shafts.
 Seventy-two dozen file handles, 12 doz. yards canvas.
 Three 4 ft. diameter best Newcastle grindstones.
 Six each gun metal cocks, $\frac{3}{8}$ -in., $\frac{1}{2}$ -in., $\frac{3}{4}$ -in., 1 in., $1\frac{1}{2}$ in., $1\frac{1}{2}$ in., and 2 in.
 Four 6 in. galvanized contractors' pumps, 28 ft. under spout.
 One set of gauges, consisting of plug and ring for the following sizes:—
 $\frac{3}{8}$ -in., $\frac{7}{16}$ -in., $\frac{1}{2}$ -in., $\frac{9}{16}$ -in., $\frac{5}{8}$ -in., $1\frac{1}{8}$ -in., $\frac{3}{4}$ -in., $1\frac{1}{8}$ -in., $\frac{7}{8}$ -in., $1\frac{1}{8}$ -in.,
 and 1 in.
 One set of gauges, consisting of plug and ring for the following sizes:—
 $1\frac{1}{8}$ in., $1\frac{1}{4}$ in., $1\frac{3}{8}$ in., $1\frac{1}{2}$ in., $1\frac{5}{8}$ in., $1\frac{3}{4}$ in., $1\frac{7}{8}$ in., 2 in., $2\frac{1}{8}$ in.,
 $2\frac{1}{4}$ in., $2\frac{3}{8}$ in., $2\frac{1}{2}$ in., $2\frac{5}{8}$ in., $2\frac{3}{4}$ in., 3 in.
 One set of gauges, consisting of plug and ring for the following sizes:—
 $3\frac{1}{4}$ in., $3\frac{3}{4}$ in., $3\frac{3}{4}$ in., 4 in., $4\frac{1}{4}$ in., $4\frac{1}{2}$ in., $4\frac{3}{4}$ in., 5 in., $5\frac{1}{2}$ in.,
 $5\frac{1}{2}$ in., $5\frac{3}{4}$ in., 6 in.
 Six long wrought spanners, each with jaws, 2 in., $2\frac{1}{2}$ in., 3 in., and 4 in.

- Two machines for cutting pipes up to 3 in. diameter, with 12 spare cutters for same.
- One hundred feet of steam tube, each 2½ in. and 3 in.
- One steam trammel for striking a circle 8 ft. diameter.
- One Richards' Indicator, complete.
- One case for managers' office, containing a set of compasses, callipers, square, spirit level, plumb bob, small hammer, punch, 2 cold chisels, one Lancashire vice, one pair of flat and one pair of round nose pliers.
- Patent packing, from ¾-in. to ½-in.
- Two spare sets of patent pipe tongs, ¼-in to 2 in.
- Two drill bows and drills complete.
- Three extra pulleys.
- One set of spare tubes for main boiler.
- One set of spare tubes for condenser.
- Four portable rivet hearths 22 in., and 2 portable forges.
- Four small anvils for outdoor work.
- Two stamps with government brands in each of 3 sizes.
- Four brand irons and holders in each of three sizes.
- Six gun metal cocks, each ¾-in., ½-in., ⅜-in., 1 in , 1¼-in., 1½-in. and 2 in. female ends.
- One 5-tons portable weighing machine.

REPAIRING SHOPS AT THE QUARRIES.—The stone used in the construction of the harbour works was brought in the first instance by water but, subsequently, much of it was conveyed by a narrow gauge railway from the quarries about 12 miles distant, and delivered where required for the works. A number of engines, pumps, cranes, skips, drilling tools, etc., being in constant and very rough use at the quarries, it was deemed desirable to have a shop on the spot where repairs and renewals could be promptly carried out and accurate records of cost obtained. The materials required for repairs were requisitioned and obtained from the stores at the harbour and the quarry shops were equipped with :

SMITHS' SHOPS :—

- Two smiths' hearths for general work.
- Four smiths' hearths for making and repairing tools.
- One fan with air main, and connections and shut off valve to each hearth.
- One large bellows with shut off valve.
- Two large anvils and cast iron stands.
- Four smaller do. do.
- One 3¼ cwt. steam hammer.
- One forge crane 3 ft. 6 in. radius with sling chains, etc.
- Two sets of smiths' tools for general work.
- Four do. do. for quarry tools.
- One conical smiths' mandril.
- One flatting plate.
- One swage block and stand.
- One strong bench vice with 8 in. jaws.
- Two do. do. 6 in. jaws.

MACHINE AND FITTING SHOP :—

- One treble-gearred break lathe as Fig. 3015, with 14 in. centres, large face plate, sliding bed 14 ft. long moved by screw, column to fix on 1 grooved foundation plate and carry the self acting slide rest, 6 steel tools, &c.
- One double geared sliding, surfacing and screw-cutting lathe, with gap, as Fig. 3021, with 8 in. centres, leading screw and change wheels, rack traverse, and all motions, self-acting or by hand, 6 steel tools, &c.
- One shaping machine (as Fig. 3066), with bed 5 ft. long, stroke adjustable up to 12 in., quick return motion, 2 rising and falling tables, and motions self acting in the horizontal and circular cuts, 6 steel tools, &c.
- One radial drilling machine (as Fig. 3047), with arm to swing through a radius of 4 ft., the spindle 1½ in. diameter. and 9 in. range, self acting or by hand, 6 steel tools, &c.

- One vertical drilling machine, (as Fig. 3048), with spindle $1\frac{1}{2}$ in. diameter, 4 in range, self acting or by hand, rising and falling table, 6 steel tools, &c.
- One bolt screwing machine, to cut threads or tap nuts $\frac{3}{8}$ -in. diameter and upwards, with all tools and accessories for removing taps and dies.
- One screwing machine for pipes up to 1 in. internal diameter.
- One screwing machine for pipes from 1 in. to 2 in. internal diameter.
- Six best fitters' vices $6\frac{1}{2}$ in. to 7 in. jaws.
- Six sets of fitters' tools similar to those for the Harbour shops.
- Two surface plates, 18 in. by 18 in.
- One circular saw bench (as Fig. 3111), with saw 36 in. diameter, adjustable fence, adjustable boring table on one side, spare saw and a set of boring tools.
- The turned steel shafting, wall boxes, brackets for bearings, pulleys, overhead-motions, belts and fastenings for each tool.

THE ENGINE for driving this machinery is of the portable type, the cylinder being or 6 and the boiler for 8 nominal horse power, to supply steam for working the machines and the steam hammer simultaneously.

RAILWAY REPAIRING SHOPS.—The engravings Figs. 3010 to 3013 illustrate works carried out by the Author's firm for the repairs and renewals of locomotives and rolling stock for a colonial line of about 100 miles. The arrangement of such shops must necessarily be varied to suit the local conditions, and it may be mentioned that, in this instance some difficulty was experienced in obtaining convenient approaches and sequence of departments on the only site available, but several years experience has proved the arrangement shown to be quite satisfactory.

The chief offices are in a portion of the passenger station, and those at the left of the plan (Fig. 3010) are devoted exclusively for stores and for the departmental management.

The tools and working plant consist of the lathes, planing, shaping and drilling machines, wheel press, fitters' benches, &c., usually found in machine shops for locomotive repairs, and there are in the carriage repairing shop a saw frame, circular saw bench with pull up gear, band sawing machine, general joiner, boring, and mortising machine, glue kettles, &c. There are six large and two small hearths, steam hammer, forge crane, blowing fan, and other plant required in the smiths' shop, a brass foundry, and copper smiths' bench and tools. The well which furnishes the water supply for these and the station buildings is in the engine room, and a spare boiler is provided so that one may always be laid off for examination or repair.

THE STEAM TRAMWAY REPAIRING SHOPS, illustrated in Fig. 3014, are equipped with the machinery and appliances requisite for working in metal and wood, and have proved sufficient for all purposes for which they are designed. The arrangement is so clearly indicated in the diagram that a detailed description may not be necessary.

ELECTRICALLY DRIVEN MACHINE TOOLS.

Examples are given in the previous sections, of cranes, pumps, &c., worked by electric motor and, at first sight, it seems singular that the engineers of this country—usually the pioneers in appliances for saving in time and cost of production—should hitherto have appeared indisposed to generally adopt this extremely convenient and efficient system.

But the reasons for this are not far to seek: the proprietors of old established works are naturally averse to the interference with output and to the outlay of capital which so radical a change involves, and have hitherto contented themselves with applying electric power to certain special tools, and to outlaying machines which cannot be conveniently reached by shafting, belts, &c. In more recently established works however, driving by electricity has been very largely adopted and the Writer does not know of a single instance in which it has been other than completely satisfactory.

In one of his admirable papers on the subject, Mr. F. J. Rowan (to whom the Writer is indebted for much valuable information) expresses the opinion that we may have to wait some time before electric cables, serving for the distribution of power, light and heat, entirely replace the present systems of shafting, pulleys and belts, and steam or hydraulic pipes, yet he looks for nothing less than this in large and well equipped works.

The advantages of electric transmission of power are mainly the extreme flexibility of the system, the facility it affords for placing tools (permanently or otherwise) where they can be employed to the greatest advantage, and the economy due to the large reduction in frictional losses incidental to main driving shafts, belts, &c. To these may be added the by no means insignificant advantage of working a single tool—or a limited number—without driving the main shafting. Any existing machine, or group of machines now driven by belt, can easily be adapted to work by electric motor, without disturbing the present transmissions.

Efficiency.—The dynamo which transforms energy into electricity and the electric motor which transforms electricity into power, are now made at the moderate prices indicated at pages 75 to 77 of Section I. According to Mr. Preece the efficiencies range from 94 to 96 per cent., whilst the frictional losses between the engine and tool driven by shafting and belts, is variously estimated at 25 to 80 per cent.; the Writer believes that 50 per cent. of useful effect is rarely attained.

Cost of installation.—No special features are required in either dynamo or motor and the approximate cost of these is easily ascertained by reference as above, or to other sources.

PORTABLE ELECTRO MAGNETIC MACHINE TOOLS.—The en-

gravings Figs. 3000A to 3000E are selected from a number of machines in successful operation and illustrate some of the ingenious arrangements devised by Mr. Rowan for attaching the tools to the work. They are serviceable and do accurate work and the outlay for an equipment for drilling, tapping and rivetting, is much less than that required for tools of the usual type and equal capacity.

Power is conveyed to them by light and flexible leads with minimum loss in transmission; it is under perfect control and labour for moving large masses to and from the machine is dispensed with.

Fixing the machine.—Fig. 3000A represents a plate to which a drilling machine is attached by magnets, and suspended in mid air, so that the only possible resistance to the feed of the drill (driven by the motor) is the holding power of the magnets. It also shows electricity employed, in the same machine, to **prevent** motion and to **produce** motion.

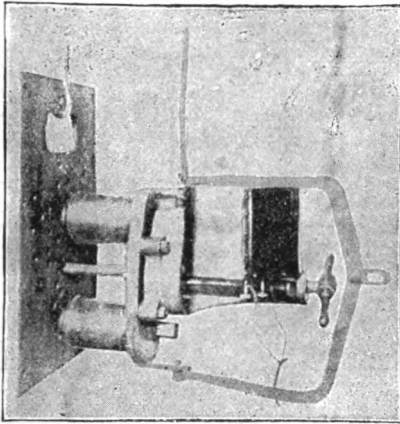

Fig. 3000 A.

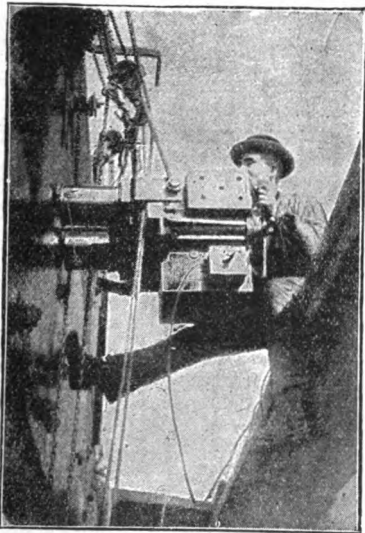

Fig. 3000 B.

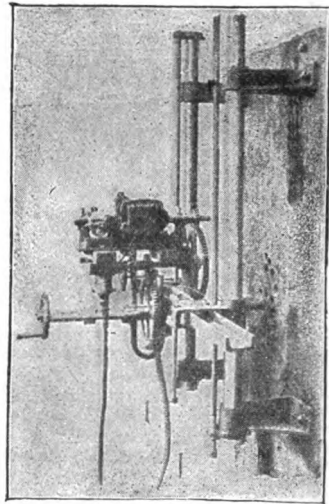
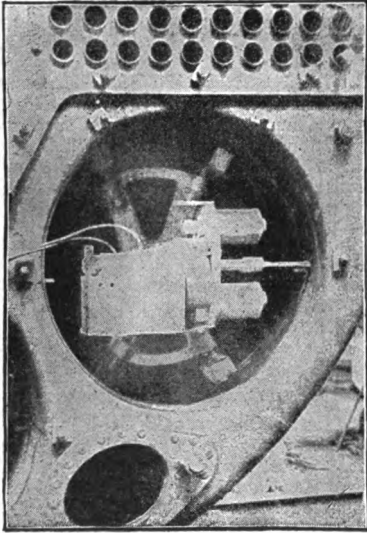

Fig. 3000 C.

ELECTRIC DRILLING AND TAPPING MACHINES.—Fig. 3000B illustrates a machine attached to the ship's side by the magnets and drilling holes 3 inches diameter out of the solid, slow speed gear being provided for tapping when the tool for that purpose takes the place of the drill.

BUTT-STRAP ELECTRIC DRILLING MACHINE.—One arrangement of these useful machines is shown in Fig. 3000c. The frame is bolted to the work and is provided with cross and longitudinal traverse motions to command a large number of holes without re-fixing. Machines of this type have drilled holes up to 5 inches diameter.

BOILER MAKERS DRILLING MACHINES, similar to Fig. 3000D are used for drilling the holes for steam mountings, stud holes, and for the large holes for steam pipes, as well as for drilling the holes around the furnace mouth. A hole $2\frac{1}{2}$ inches diameter is drilled in a steel plate $\frac{3}{4}$ inch thick in about $2\frac{1}{2}$ minutes.



[Fig. 3000 D.

The speed of working is in proportion with the diameter of the hole and the power of the machine; for 1 inch holes the feed usually varies from $\frac{1}{4}$ inch to $\frac{3}{8}$ inch per minute. The tool referred to, with motor of $1\frac{1}{2}$ horse power, drills holes of 1 inch diameter and depth in 70 seconds after fixing.

The saving in cost of working must evidently be influenced by many conditions but—including the time spent in fixing—one man working the electric drill, does the work of at least four experienced hand drillers.

The current.—The tools are arranged to suit almost any pressure of current; in the examples referred to, it is from 12 to 15 ampères at 70 volts.

SHAFT DRIVEN ELECTRIC DRILLING MACHINES are useful for drilling locomotive frames (or similar work), power being transmitted by a telescope shaft with universal coupling, or flexible shaft. The motor is carried on a barrow or trolley for convenience of removal, or it may be fixed to a bench or wall.

ELECTRIC RIVETTING MACHINE.—These machines (not illustrated) are attached to the work by magnets and have great striking power; they will deliver blows at any angle at which rivets may come through the plate which have not been punched quite fair.

WORK PERFORMED.—Machines of the type, Fig. 3000A, have drilled many thousands of holes of 1 inch diameter in steel ship plates and protecting decks, beside enlarging holes to almost any diameter. The same tool is also used with equal success in boiler shops.

MACHINE TOOLS.

SELF ACTING BRAKE LATHE.—The engraving (Fig. 3015) represents a treble geared machine with 24 in. centres and the smaller machines are of similar construction but are fitted with double gear, all being adapted for sliding, surfacing and boring, also for screw cutting if desired, and the separate price for this motion will be found in the subjoined list.

The fast headstock is secured to a strong cast iron bed plate, truly planed, and the gear is arranged to drive in single, double, or treble purchase.

The sliding bed is carried on planed base plates and is moved by ratchet and screw for uncovering the pit in front of the face plate or for adjusting the width of the gap when large objects are being bored or surfaced. The loose headstock is provided with all appliances for turning tapers and, in the larger sizes, it is moved along the bed by rack and pinion.

The saddle is fitted with a back following stay and quick hand traverse; the sliding and surfacing motions are self acting, and the compound slide rest is indexed for turning cones.

Every lathe is provided with a strong base plate with \perp slots as shown, to which is secured the column for carrying the slide rest when it is removed from the lathe bed for turning work of large diameter, but if desired a second rest is provided at a relatively extra small cost, to avoid changing from the bed to the column or vice versa. The self acting motions are transmitted to the slide rest and to the column by screw and self acting feed motion worked from overhead, and the traverse of the column is sufficient to turn any object the lathe will take in. Each lathe is complete with overhead motions and rocking shaft for the feed of the slide rest or for traversing the column, screw keys, &c.

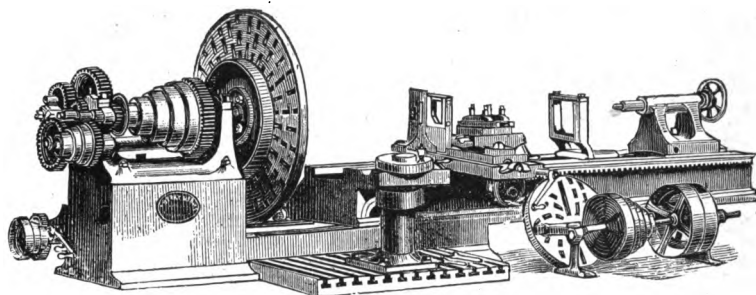

Fig. 3015.

PRICES OF SELF ACTING BREAK LATHES, Fig 3015.

Height of centres... ..	12in.	16in.	18in.	24in.	30in.	36in.
Lengths of movable bed	10ft.	10ft.	10ft.	12ft.	20ft.	25ft.
Length between centres when gap is closed	7ft. 9in.	7ft. 6in.	6ft. 9in.	8ft. 6in.	16ft.	20ft.
Will turn diameter of	5ft. 6in.	6ft.	10ft.	12ft.	11ft.	12ft.
Diameter of face plate	4ft.	5ft.	6ft.	7ft.	9ft.	8ft.
Width of gap from front of face plate	3ft. 6in.	3ft. 6in.	6ft.	6ft.	6ft.	6ft.
Price of lathe	£168	£225	£292	£420	£600	£1045
Approx. weight tons	5	7½	10	17	23	43
Extra if screw cutting	£22	£23	£25	£32	£80
Per foot of extra bed	£4	£5	£6	£7	£8	£11

The cost of packing for shipment and delivery f.o.b. is 5 per cent.

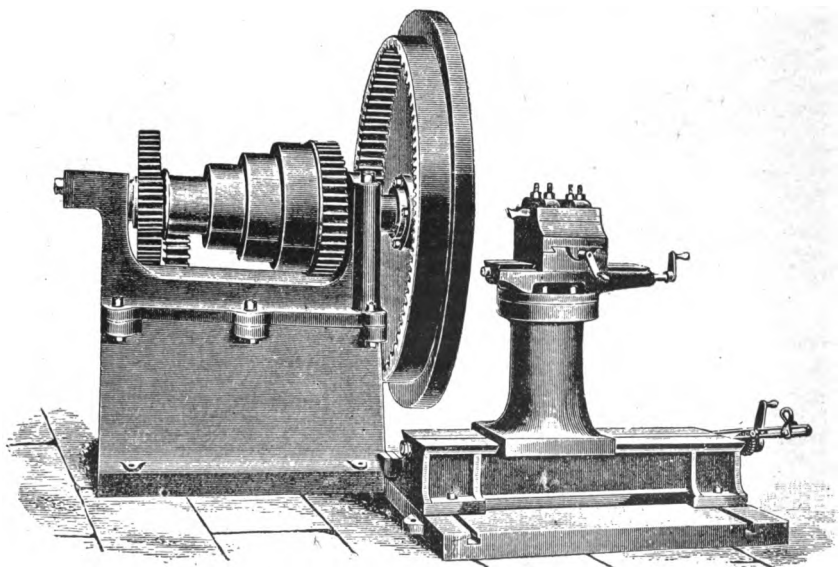

Fig. 3016.

DOUBLE AND TREBLE GEARED SURFACING LATHE. Fig. 3016

The headstock is mounted on a heavy cast iron bed, planed on the upper surface, and fitted with double gear, the third purchase being obtained by a pinion engaging the large internal spur wheel on the back of the base plate. The movable bed is planed and grooved to carry the column and compound slide rest, and these can be set at a right angle with the face plate, or parallel with it, as desired, the feeds being worked by hand, or self acting in all motions, by ratchet gear, for surfacing the largest diameter the machine will take in. The compound slide rest has an indexed swivel motion for turning conically, and the ratchet feed motion may be disengaged from the bed and applied to either side of the rest.

The engraving, Fig. 3016, shows a treble geared lathe without a loose headstock, adjustable by screw and ratchet gear on a sliding bed, but these can be supplied at comparatively small cost if they should be required. Each lathe is complete with overhead motions, rocking shaft for giving a self acting feed to the rest and to the saddle, a full set of screw keys, &c.

PRICES OF DOUBLE AND TREBLE GEARED SURFACING LATHES, Fig. 3016

Height of centres	12in.	14in.	16in.	18in.	24in.
Diameter of face plate	4ft.	5ft.	5ft.	6ft.	7ft.
Will turn diameter of	5ft.	5ft. 6in.	6ft. 3in.	7ft.	8ft. 3in.
Will turn width of	2ft. 6in.	2ft. 9in.	3ft.	3ft. 6in.	3ft. 6in.
Length of movable bed carrying pillar rest	4ft. 6in.	4ft. 6in.	4ft. 10in.	5ft. 2in.	5ft. 2in.
Price of double geared lathe... ..	£89	£118	£134
Approximate weight of double geared lathe					
	tons	2 $\frac{3}{4}$	3 $\frac{3}{4}$	4 $\frac{1}{2}$...
Price of treble geared lathe	£120	£135	£155	£200	£270
Approximate weight of double geared lathe					
	tons	3 $\frac{1}{2}$	4 $\frac{1}{2}$	5	5 $\frac{1}{2}$

The cost of packing for shipment and delivery f.o.b. is 5 per cent.

DUPLEX RAILWAY WHEEL LATHE, Fig. 3017, illustrates a type of machine which is essential to all locomotive and carriage shops for turning, boring or bossing railway or tram car wheels. The different sizes vary to some extent in design, but all have two headstocks as shown, and will turn a pair of wheels on their own axle, without torsion, or will turn two tyres simultaneously, or, if desired, one face plate may be used for turning a wheel or boring a tyre whilst a wheel is being bored or bossed on the other face plate. The massive bed plate is truly planed on the sliding surfaces and is provided with two headstocks, one being fixed and the other movable on the bed. The face plates are geared externally and are driven by pinions, which may be disengaged separately; that carried in the fixed headstock is provided with four strong jaws, which form a chuck for firmly gripping the tyres, and it has a quick speed internal gear, so that the two face plates may be run at different speeds as required for the work from time to time to be performed. The two compound slide rests are adjustable on the bed by rack and pinion, and are self acting, both ways, by ratchet motion worked from above, a swivelling motion being provided for adjusting the tool to the angle of the tyre.

Each face plate has two drivers, the centres are arranged for outside crank pins, and all these lathes are sent out complete with overhead driving and feed motions, screw keys, &c. The extra cost if both face plates are fitted with four jaws, and for four compound slide rests instead of two, as above referred to, will be found in the subjoined list of prices.

PRICES OF DUPLEX WHEEL LATHES. Fig. 3017.

Height of centres	17in.	21 $\frac{1}{2}$ in.	27 $\frac{1}{2}$ in.	33 $\frac{1}{2}$ in.	36 $\frac{1}{2}$ in.
Length between centres	7ft.	9ft.	9ft.	9ft.	9ft.
Will turn wheels up to diam.	2ft. 10in.	3ft. 6in.	4ft. 6in.	5ft. 6in.	6ft.
Diameter of face plate	2ft. 10in.	3ft. 6in.	4ft. 6in.	5ft. 6in.	6ft.
Price with two compound slide rests	£140	£197	£276	£358	£410
Price with four ditto	£170	£234	£318	£402	£452
Price for four jaws in second face plate,					
extra	£12	£20	£20	£20	£20
Approximate Weight tons	4 $\frac{1}{2}$	7	9	14 $\frac{1}{2}$	16 $\frac{1}{2}$

The cost of packing for shipment and delivery f.o.b. is 5 per cent.

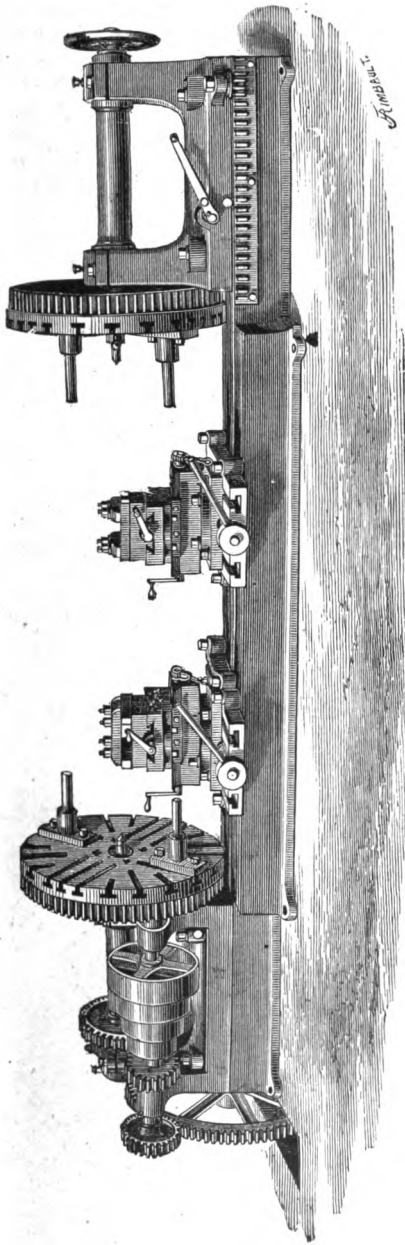

Fig. 3017

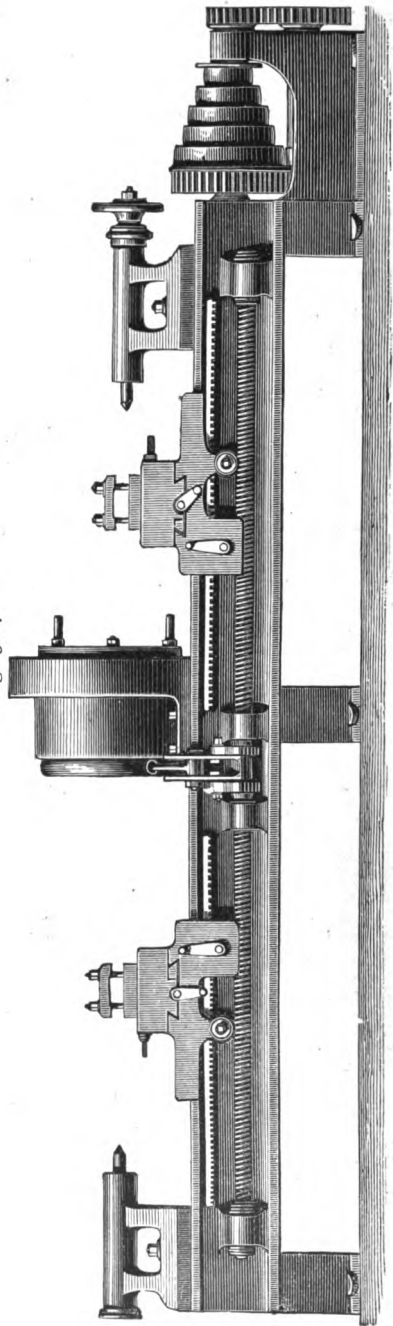

Fig. 3018

THE AXLE TURNING LATHE, Fig. 3018, will turn both the end journals of locomotives, railway carriage or other axles, simultaneously and without torsion. The tool consists of a strong lathe bed, supported on three standards; the upper face of the bed is carefully planed, and is fitted with a central headstock and two loose headstocks, one of which has a traversing motion for use when an axle has been finished and another is to be put in. The central headstock is specially constructed for the axle to be passed through and driven by it, the outer ends being carried in the hardened steel centres with which the end headstocks are provided. The two compound slide rests—one on each side of the central headstock—are self acting on the bed and have also a quick rack and pinion hand traverse. The power for working all motions is transmitted from the speed cone and gear at the end of the lathe by means of a shaft which extends the whole length of the bed.

The proportions of these lathes are as follows:—

The central headstock will take in any diameter up to 12 inches, and the end headstocks admit a length of 9 ft. between centres.

The price of the machine complete, with overhead motions, screw keys, &c., is £220, and the weight is about 5½ tons.

Packing for shipment and delivery f. o. b. London, costs 5 per cent.

PULLEY AND WHEEL TURNING LATHES of the type Fig. 3019, will turn, bore, face, and boss pulleys, fly wheels or geared wheels of any diameter within the limits indicated in the subjoined list. This work can be done on any well designed lathe which has the requisite dimensions, and every purpose will be answered by such tools if they are only used intermittently or at long intervals; but if a machine can be continuously employed on such work—or nearly so—that now referred to will be found to give highly satisfactory results, because a wheel can be bored, faced on the boss, and the rim turned on the face and both edges, at one setting, and thus insure great accuracy and economy in time, and in the cost of labour.

The driving headstock is fitted with a spindle of large diameter, cast hollow for the boring bar to pass up it, and carried in heavy gun metal bearings.

The quick speed required for boring, turning, and facing bosses is transmitted from the 5-speeded cone, the slower speed necessary for turning the face and edges of large pulleys, or fly wheels, being obtained by using the pinion and gear behind the face plate.

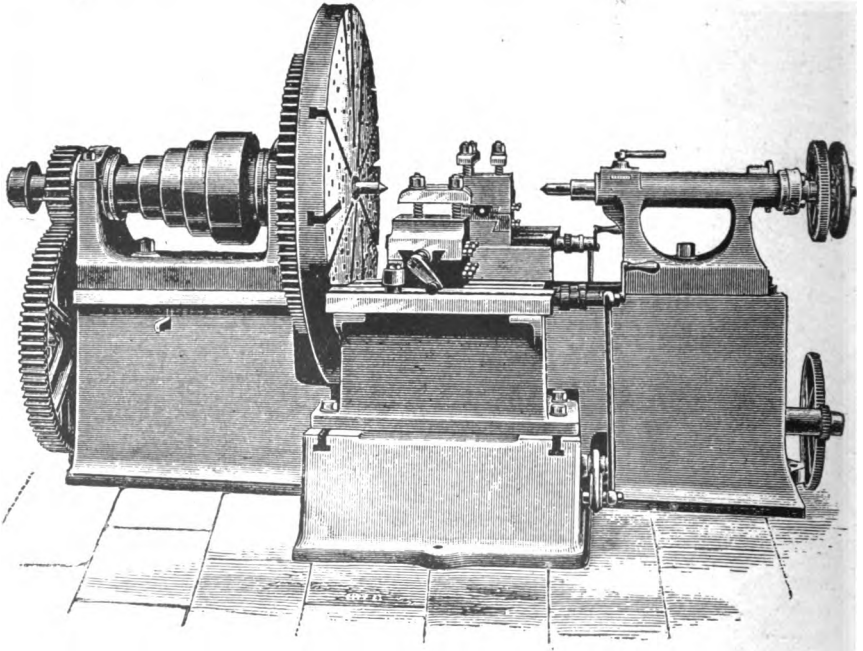

Fig. 3019.

The loose headstock is mounted on a massive box bed, which is adjustable on the base plate, the spindle has a transverse motion, and carries a tool holder for turning bosses, and there is a self acting motion for boring.

The rest has self acting sliding motion, and one for rounding the face of pulleys, &c., and it can be adjusted on the base plate to suit the dimensions of the work to be done.

The two larger sizes of machines are provided with an adjustable swivel motion for setting the tool to the angle required, for turning rope pulleys or car wheels, and the spindle in the loose headstock of the large machines is bored up to receive a centre, the end of a boring bar, or a tool holder.

PRICES OF PULLEY AND WHEEL TURNING LATHES, Fig. 3019.

To turn any size from 12 in. diam to	42in.	42in.	60in.	72in.
Diameter of face plate	3ft. 9in.	3ft. 9in.	5ft. 0in.	5ft. 0in.
Traverse of slide rest	16in.	3ft. 0in.	2ft. 6in.	2ft. 6in.
Price with one side rest	£75	£105	£154	£182
Ditto two do.	£85	£115	£173	£202
Approximate weight tons	2½	3½	5	6

Each machine is complete with overhead motions and screw keys, and the cost of packing for shipment and delivery f.o.b. London is 5 per cent.

THE DOUBLE GEARED LATHE WITH BOX END, illustrated by Fig. 3020, has 12 in. centres and self-acting, sliding, surfacing, and screw cutting motions, but this type is made in all sizes up to about 18 in. or 20 in. centres, and with any of the above named motions, or any combination of them.

The fast headstock is, in all cases, fitted with a 5-speed cone and spur gear of ample strength for the heaviest work for which the tool is adapted. The teeth of the spur wheels are machine dressed, or, at an extra cost of about 5 per cent., the wheels will be cut out of the solid. The bearings are parallel, unless special instructions are given that they shall be conical.

The saddle is self acting in all motions, or any combination of them, and the cost of lathes with the respective motions will be found in the accompanying list of prices. The sliding and surfacing motions are transmitted from a back shaft driven from the fast head, and there is quick hand traverse by rack and pinion, with compound gear; an extra stay for bolting to the bed, as shown in the engraving, will be supplied at a small extra cost.

The compound slide rest can be worked self acting or by hand, and is indexed to set at any angle, and to turn conical work; the loose headstock is mounted on a saddle for turning tapers. Lathes for screw cutting have the leading screw in mild steel accurately cut and fitted with double disengaging clamps; a complete set of change wheels, overhead motions, screw keys, &c., are sent with each lathe.

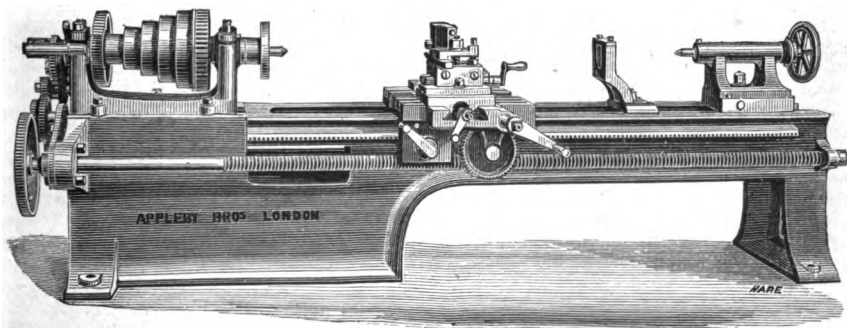

Fig. 3020

PRICES OF DOUBLE GEARED LATHES, FIG. 3020.

Height of centres	12in.	14in.	16in.	18in.
Length of bed	20ft.	20ft.	20ft.	20ft.
Admits between centres	14ft. 6in.	13ft. 3in.	13ft.	12ft. 4in.
Will turn diam. of (when gap piece removed)... ..	4ft.	4ft. 6in.	4ft. 10in.	5ft. 2in.
Width of gap	1ft. 8in.	1ft. 8in.	1ft. 8in.	2ft.
Price to slide and surface only	100	£150	£160	£215
Price to slide and screw cut (surfacing by hand)	£102	£155	£165	£220
Price to slide, surface and screw cut (self acting)	£116	£170	£175	£235
Extra per foot of bed	£3	£3 10	£4	£4 10
Approximate weight tons	3½	5½	5½	8

The cost of packing for shipment and delivery f.o.b. is 5 per cent.

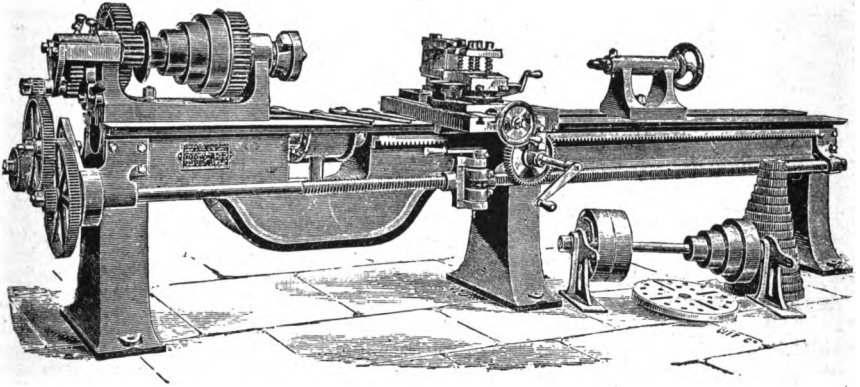

Fig. 3021.

SELF ACTING, SLIDING, SURFACING, AND SCREW CUTTING LATHES, with or without gap in bed. Fig. 3021 represents a lathe with 9 in. centres and all motions, and (subject to the modifications necessary to suit the various sizes) indicates the design generally adopted in the construction of the tools referred to in the following description and in the subjoined list of prices :—

The bed is made with or without the gap, which is shown in the engraving, and is supported on two or more standards, as required; the upper surfaces are accurately planed and scraped, and these, as well as the cross section, are of ample proportions for the several sizes of tools.

The fast headstock has single and double gear wheels, steel spindle, with conical or parallel bearings working in hard gun metal or phosphor bronze bearings. Any size of lathe can be made with self acting motions for sliding, surfacing and screw cutting, or for sliding and surfacing only, or for sliding and screw cutting, and the prices for tools with each of these combinations will be ascertained by reference to the list. The screw cutting lathes have a guide screw accurately cut, double clamp nuts, and 22 change wheels, also reversing motion for cutting right or left hand threads and nuts, and, if desired, the loose headstock is arranged for mounting on a saddle for turning taper work.

The self acting surfacing motion is taken from a back shaft driven by gear, and this and the lead screw clear the largest diameter the gap will admit. The saddle has a quick hand traverse by rack and pinion, and the slide rest is indexed for setting at any angle required for turning conically; each tool is provided with suitable overhead motions, screw keys, &c.

PRICES OF SLIDING, SURFACING, AND SCREW CUTTING LATHES, Fig. 3021.

Height of centres ...	4½in.	5in.	6in.	7in.	8in.	9in.	10in.
Length of bed ...	4ft. 6in.	5ft.	6ft.	7ft.	8ft.	12ft.	12ft.
Will admit between centres ...	2ft. 6in.	2ft. 9in.	3ft. 3in.	3ft. 9in.	4ft. 4in.	8ft.	7ft. 6in.
Width of gap ...	5in.	5½in.	8in.	9in.	13in.	13in.	15in.
Depth of gap ...	4½in.	4½in.	7in.	7in.	8in.	10in.	10½in.
Price to slide and surface	£23 0 0	£27 10 0	£34 5 0	£39 0 0	£52 0 0	£63 0 0
Price to slide and screw cut ...	£18 10 0	£23 10 0	£28 0 0	£35 0 0	£40 0 0	£53 0 0	£64 0 0
Price to slide, surface, and screw cut	£28 0 0	£32 10 0	£40 0 0	£47 0 0	£60 0 0	£72 0 0
Extra length of bed per foot ...	£0 18 0	£1 1 0	£1 2 6	£1 5 0	£1 10 0	£1 15 0	£2 5 0
Extra for loose head on saddle ...	£0 15 0	£0 15 0	£1 0 0	£1 1 0	£1 2 6	£1 5 0	£1 7 6
Approximate weight cwts.	5½	8½	10	15	21	30	36

If with straight beds (without gap) deduct 5 per cent. Packing for shipment and delivery f.o.b London 5 per cent.

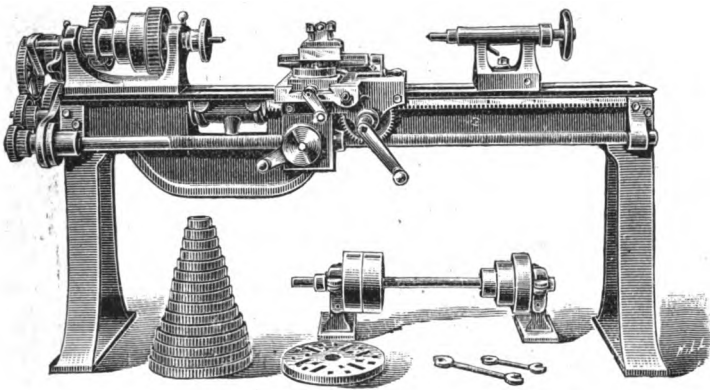

Fig. 3022.

PRICES OF SINGLE AND DOUBLE GEARED LATHES, Fig. 3022.

Height of centres	3½in.	4½in.	5in.	6in.	7in.
Length of bed	3ft. 6in.	4ft. 6in.	5ft. 0in.	6ft. 0in.	7ft. 0in.
Will admit between centres ..	1ft. 9in.	2ft. 6in.	2ft. 9in.	3ft. 3in.	2ft. 9in.
Number of speed cones	3	3	4	4	4
Price for single speed lathes ..	£14 0	£15 15	£18 0	£22 0	£24 0
Ditto double-geared lathes ..	£15 0	£17 0	£19 5	£24 0	£25 10
Extra length of bed per foot ..	£0 16	£1 0	£1 0	£1 4	£1 4
Ditto, if with gap in bed	£1 0	£1 5	£1 10	£2 0	£2 5
Approximate weight cwts.	4½	5½	6½	7½	9

The cost of packing for shipment and delivery f.o.b. is 5 per cent.

SINGLE AND DOUBLE GEARED LATHES, Fig. 3022, are made with straight or gap beds truly faced and fitted with single or double geared headstocks as required, compound slide rest, eccentric hand rest, face plate and driver, and each tool is sent out complete with overhead motions and screw keys.

DOUBLE GEARED SCREW CUTTING FOOT LATHES WITH GAP BEDS.—Fig. 3023, represents a 5 in. centre lathe with gap bed 5 ft. long, and sliding, surfacing, and screw cutting motions to work by hand or self acting; the other sizes referred to in the sub-joined list of prices are similar to this in design and arrangement, and they include either overhead motions or crank and treadle for foot driving. The fast headstock has a steel spindle with conical bearings, and the teeth of the wheels are carefully dressed to insure smooth working. The leading screw is made of best wrought iron or mild steel, accurately cut, and a complete set of change wheels for screw cutting, with index plate, is provided, also double clamp nuts of gun metal and adjustable back stay. There is a quick return motion by rack and pinion for the carriage, and the compound slide rest is arranged to surface or turn conically and is indexed for that purpose. The main shaft, which carries the heavy fly wheel and the large speed cones, runs in antifriction bearings, and the lathe is complete with face plate, driving plate and tool board behind the bed, screw-keys etc. If desired, the cone pulleys for all sizes of lathes up to 5 inches, centres will be made for round bands.

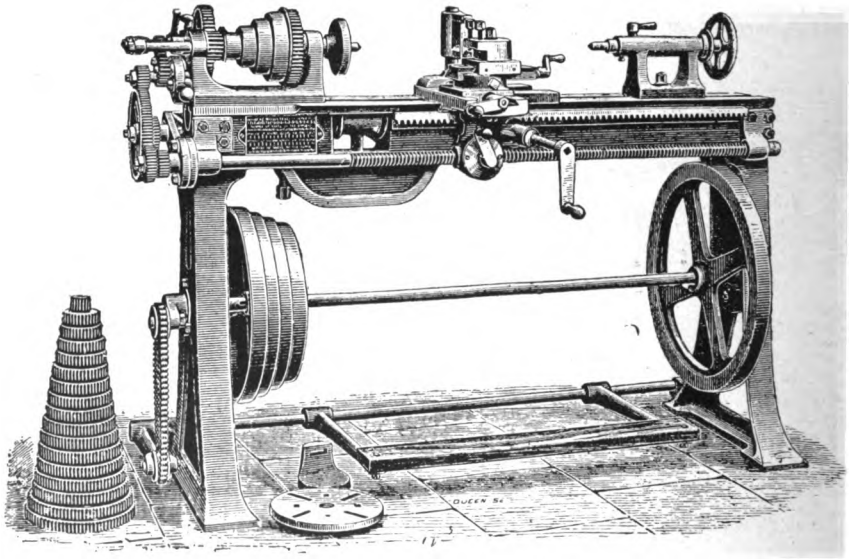

Fig 3023.

PRICES OF DOUBLE GEARED SCREW CUTTING LATHES, Fig. 3023.

Height of centres	3½ in.	4½ in.	5 in.	6 in.
Length of bed	3 ft. 6 in.	4 ft. 6 in.	5 ft. 0 in.	6 ft. 0 in.
Will admit between centres	1 ft. 9 in.	2 ft. 6 in.	2 ft. 9 in.	3 ft. 3 in.
Width and depth of gap	4½ ft. by 4 in.	5 ft. by 4½ in.	5½ ft. by 4½ in.	7 ft. by 6½ in.
Price to slide and screw cut	£21 0 0	£22 10 0	£28 0 0	£33 15 0
Ditto, with back shaft	£32 0 0	£40 0 0
Extra length of bed per foot	£1 5 0	£1 5 0	£1 10 0	£1 10 0
Approximate weight .. cwt.	5	7½	11	14

The cost of packing for shipment and delivery f.o.b. is 5 per cent.

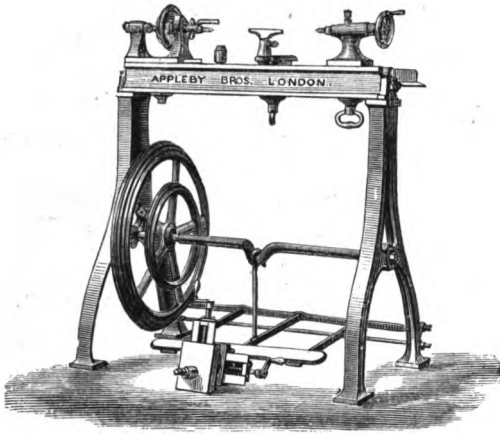

Fig. 3024.

FOOT LATHES of the type shown in the engraving, Fig. 3024, are much lighter in design than those previously referred to, and are intended for amateur or other light work, or for use on board ship; but for the latter purpose, a tool similar to Fig. 3023 will be found more generally useful.

The beds are carefully planed and surfaced, and are fixed to cast iron standards with broad feet for bolting to the floor, and bearings for the crank shaft and the treadle gear. The speed cones are grooved for round bands, or the larger sizes (from 5 to 7 inch centres) can be made for flat belts. The fast headstock is fitted with a hardened steel centre, driving and butterfly chuck, and the rest, and the loose headstock with steel centre, are adjustable on the bed. Screw-keys are provided with each tool, and the cost of extra length of bed, and of compound slide rests will be found below.

PRICES OF FOOT LATHES, Fig. 3024.

Height of centres	3½ in.	4½ in.	5 in.	6 in.	7 in.
Length of bed	3 ft. 0 in.	3 ft. 0 in.	3 ft. 6 in.	4 ft. 0 in.	6 ft. 0 in.
Price of Lathes	£7 10 0	£8 10 0	£10 10 0	£12 0 0	£15 10 0
Extra for compound slide rest ..	£4 0 0	£4 5 0	£5 0 0	£5 15 0	£6 15 0
Extra length of bed per foot ..	£1 0 0	£1 2 6	£1 2 6	£1 5 0	£1 7 6

The cost of packing for shipment and delivery f.o.b. is 5 per cent.

CHASING LATHES vary greatly in design and arrangement, but that illustrated by Fig. 3025 is a good example of a tool of this useful type for miscellaneous work such as screwing and facing bolts, studs, pins, and set screws of all kinds and for many other purposes.

The fast headstock is fitted with a case hardened wrought iron spindle with open sides to allow bolts to be turned and the heads chased, and, with the chasing apparatus, will do the work of a screwing machine. The spindle is hollow, so that a bar of any diameter within the compass of the machine, or of any length, may be passed through and gripped by a coned chuck, which is provided, for centering the work.

The saddle has a self acting feed motion by screw which is engaged by double clamp nuts, and quick hand traverse by rack and pinion.

The Capstan rest carries five tools, which are revolved into their proper positions and securely held there by a spring catch with releasing lever.

The apparatus for chasing is fixed at the back of the sliding carriage, and can be instantly brought into operation or disengaged; a stop which automatically regulates the length of cut is provided, and also appliances for turning this gear out of the way.

The machine is furnished with five sets of chasing tools, seven sets of conical holders for gripping and centering the iron from ¼ in. to 1 in. diameter, five tool holders and ten sample tools, reservoir for lubricant fitted to the sliding carriage, trough below bed to receive waste lubricant, with draw-off cock, overhead motions and full set of screw keys.

The dimensions and prices of this tool are:—

Height of centres	7 in.
Length of bed	6 ft.
Admits between centres ..	2 ft. 6 in.
Diameter of hole in spindle ..	1½ in.
Price of machine	£97 0 0
Price of 9 spare sets of conical holders ..	£5 10 0
Extra chasing tools, per set ..	£0 15 0
Approximate weight	1 ton

The cost of packing for shipment and delivery f.o.b. is 5 per cent.

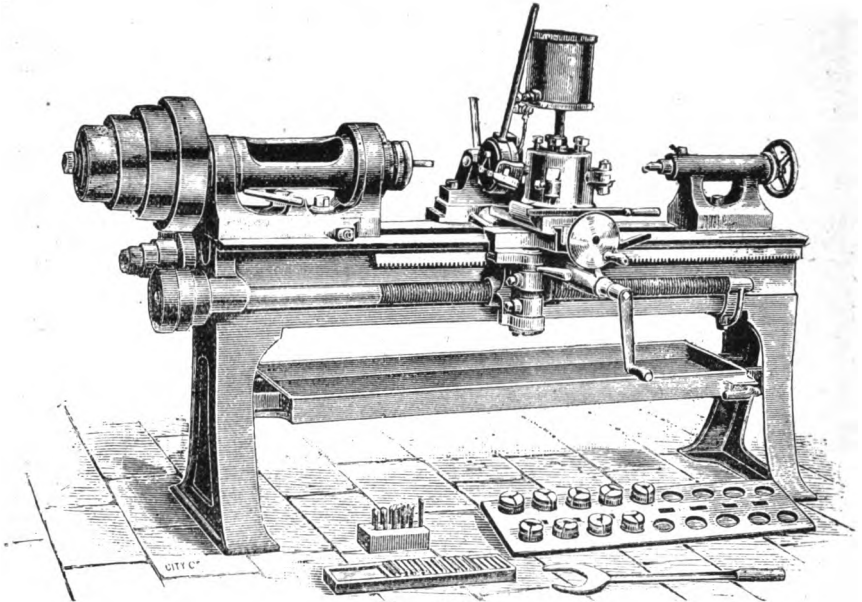

Fig. 3025.

DOUBLE GEARED CAPSTAN AND CHASING LATHE.—In general arrangement this tool resembles that last described, but the bed is 7 ft. long and more massive, the centres are $8\frac{1}{2}$ in., and the four speed cones and double gears are carried between the fast head-stock standards, in the manner indicated in Fig. 3020.

The gripping chuck and conical holders take bars from $\frac{3}{4}$ in. to $2\frac{7}{8}$ in. diameter, and the saddle has a self acting feed motion driven by gear, when cutting square or large V threads, or by belt in the high speeds, a lever and clutch being provided for alternately working either motion. The capstan rest has six tool holders, and the undernamed tools and fittings are supplied with each lathe:—

Nine sets of screw tools for $\frac{3}{4}$ in. to $1\frac{1}{2}$ in. diameter.

Thirteen sets of conical holders for $\frac{3}{4}$ in. to 2 in. diameter.

Six tool holders and 12 sample tools.

Tool board, reservoir for lubricant, and trough under bed with draw off tap, etc.

A complete set of change wheels.

Overhead motions and screw keys.

The price of the tool as above is £130.

The approximate weight is 33 cwt., and the cost of packing for shipment and delivery f.o.b. is 5 per cent.

The cost of 13 spare sets of conical holders is £8.

HOLLOW SPINDLE CAPSTAN AND CHASING LATHES, generally similar to those last described but of lighter construction, are very useful in shops where but little heavy work is required.

Each machine is sent out with its proper outfit of tools and accessories as specified for the lathe, Fig. 3025, and the prices with single and double gear will be found below.

PRICES OF HOLLOW SPINDLE CAPSTAN AND CHASING LATHES.

Height of centres	6in.	7in.
Length of bed	6ft.	6ft.
Admits between centres	2ft. 6in.	2ft. 6in.
Diam. of hole in spindle	1 $\frac{1}{2}$ in.	1 $\frac{3}{4}$ in.
Price with single gear	£73 10 0	£88 10 0
" double gear	£76 10 0	£93 0 0
Extra for 9 spare sets conical holders	£5 0 0	£5 10 0
Approximate weight cwis.	16	20

The cost of packing for shipment and delivery f. o. b. is 5 per cent.

HOLLOW SPINDLE CAPSTAN AND CHASING LATHE, with centres 6½ in. and bed 6 feet long, the hole in spindle 1½ in. diameter, saddle self acting by screw and a quick hand traverse by rack and pinion. Complete with capstan rest, five tool holders, and ten sample tools, adjustable loose headstock, overhead motions and screw-keys :

Price with single gear £38 0 0
 Ditto, double gear £40 10 0

If without gripping chuck, tool holders or sample tools, deduct £5 10s.

The approximate weight is 12 cwt., and the cost of packing for shipment and delivery f.o.b. is 6 per cent.

STAY AND STUD CUTTING LATHES (illustrated by Fig. 3026) are specially designed for cutting or chasing the threads on fire box stays, bolts, studs, or similar work.

The motions are entirely self acting, and after the chasing tool has been set to run the distance required the slide rest is automatically released without stopping or reversing the lathe, and is brought back by a spring into the position required for the next cut ; these operations are repeated until the work has been completed, when the feed ceases to act.

The feed can be set to cut threads of any depth, and any number of stays, studs, or both, can be cut, uniform in size, at a minimum cost, and without attention beyond that of supplying the work to the machine.

The subjoined prices include all needful accessories, such as overhead motions, water can, and screw keys.

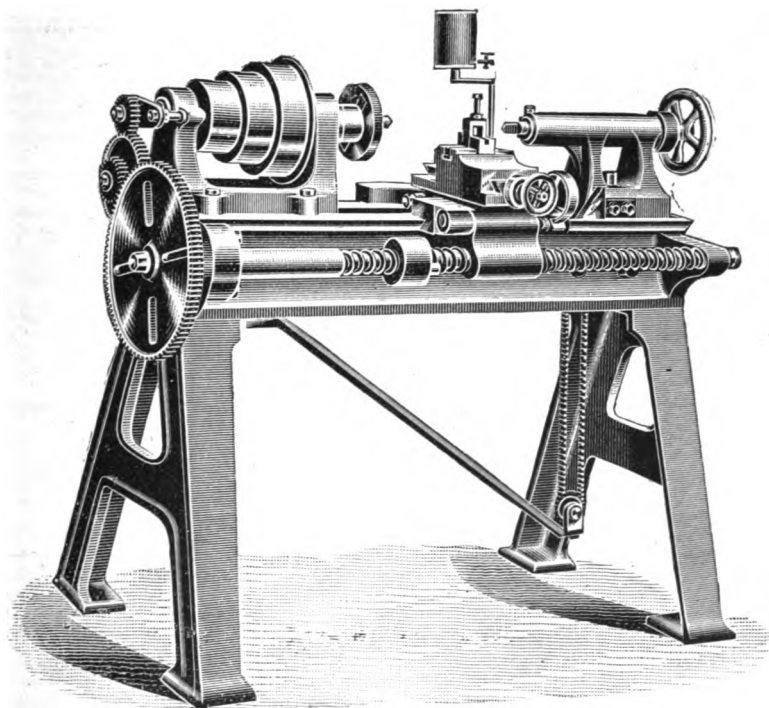

Fig. 3026.

PRICES OF STAY AND STUD CUTTING LATHES, Fig. 3026.

To chase any diameter up to	1½ in.	2 in.
To take in lengths up to	12 in.	18 in.
Price of machine as described	£55 0 0	£65 0 0
Approximate weight cwts.	12	14

The cost of packing for shipment and delivery f.o.b. is 5 per cent.

DOUBLE STUD CUTTING LATHES, but without the automatic motion of Fig. 3026, have longer beds, two dead centres, and two slide rests, each with a quick return motion worked from a cam on the spindle, so that two bolts or studs can be chased at the same time or in sequence, as desired.

The bed is 7 feet long, the distance between centres is 15 in., and the machine is complete with overhead motions and screw keys.

The price of the double ended lathe is £58.

The approximate weight is 15 cwt., and the cost of packing for shipment and deliver f.o.b. is 5 per cent.

BOLT AND NUT TURNING LATHES turn out high class work and are made in two sizes. The smaller size finishes the sides and chamfers the edges of nuts for bolts of $\frac{1}{4}$ -in. to 1 in. diameter and has seven arbors or mandrils for chucking the nuts, also an apparatus for taking them off the arbors.

The larger size is for work from $\frac{3}{8}$ -in to 2 in. diameter, and has eight mandrils and, when required for finishing bolts or set screws, the machines are made to centre and round the ends.

Both sizes of lathes have two slide rests and are sent out complete with all accessories ready for work, exclusive of tools, but including overhead motions and screw keys.

PRICES OF BOLT AND NUT TURNING LATHES.

For machinery bolts	$\frac{1}{4}$ in. to 1 in.	$\frac{3}{8}$ in. to 2 in.
Price of machine as above described... ..	£45 0 0	£72 0 0
Approximate weight cwt.	11	16

The cost of packing for shipment and delivery f. o. b. is 5 per cent.

CHASING, SLIDING, AND ENDING LATHE.—This compact and economical tool combines, in one machine, the operations of turning, heading, pointing, and chasing, bolts, screws, &c.

The first head is for heading and pointing, the second for chasing and third for sliding, and is made in the two sizes referred to below.

The bed is made hollow to receive the turnings and the waste lubricant, and each machine is provided with overhead motions and screw keys.

PRICES OF CHASING, SLIDING, AND ENDING LATHES.

Height of centres	6 in.	7 in.
Length of bed	14 ft.	16 ft.
Will screw diameter of	$\frac{3}{8}$ -in. to 1 $\frac{1}{2}$ in.	$\frac{1}{2}$ -in. to 1 $\frac{1}{2}$ in.
Price of machine	£155	£190
Approximate weight tons	1 $\frac{1}{2}$	2 $\frac{1}{4}$

The cost of packing and delivery f. o. b. is 5 per cent.

LATHE FOR TURNING SOCKET AND FLANGED PIPES.—This useful machine is made in three sizes, and turns out accurate work at a minimum cost for labour.

Several arrangements have been made for this purpose, but probably the best of them consists of a strong bed with the necessary supports and provided with two revolving spindles, one of which carries a cutter for machining the inside of the socket, whilst that at the other end turns the spigot. When used for turning and facing flanged pipes, both spindles carry cutters suitable for that purpose. The pipe is fixed in two chucking stands, and the cutters are brought up either self acting or by hand. Each machine is provided with two outside and two inside cutting heads, two chucking stands, overhead motions and screw keys.

In some cases the lathe is provided with a handy crane for lifting and chucking the pipes and delivering them to the other side, but a more economical arrangement, where it can be adopted, is to roll the pipes on an inclined plane from the dressing shop to the machine, and over another inclined plane from the machine to where they are coated with composition, or to railway trucks or ships as the case may be.

PRICES OF PIPE TURNING LATHES.

To machine pipes of any diam. between ..	2in. & 6in.	6in. & 12in.	12in. & 45in.
Ditto, ditto length in feet ..	9ft.	9ft.	13ft.
Price of machine complete as above ..	£170	£220	£470
Approximate weight tons	5	7	17

Packing for shipment and delivery f.o.b. 5 per cent.

ROLL TURNING LATHES.—This tool consists of a strong bed fixed to the foundations, and provided with a heavy fast headstock with worm and wheel driving gear, the worm running in an oil bath. The saddle is extra strong, self acting longitudinally, and fitted with compound slide rest, also a rack and pinion motion for quick hand traverse. Each machine is complete with two steady rests, one driver, overhead motions, and screw keys. As it is sometimes convenient to fix tools of this kind at a distance from a line of shafting, the price is given with and without a special engine of the power required to work the lathe, steam being taken to it from the boiler which supplies the rolling mill engine or from other convenient source.

PRICES OF ROLL TURNING LATHES.

To turn rolls any diameter up to	12in.	24in.
To turn rolls any length up to	9ft.	13ft.
Price of lathe complete	£145	£240
Approximate weight tons	5½	8½
Price of lathe with engine	£160	£266

The cost of packing for shipment and delivery f.o.b. is 5 per cent.

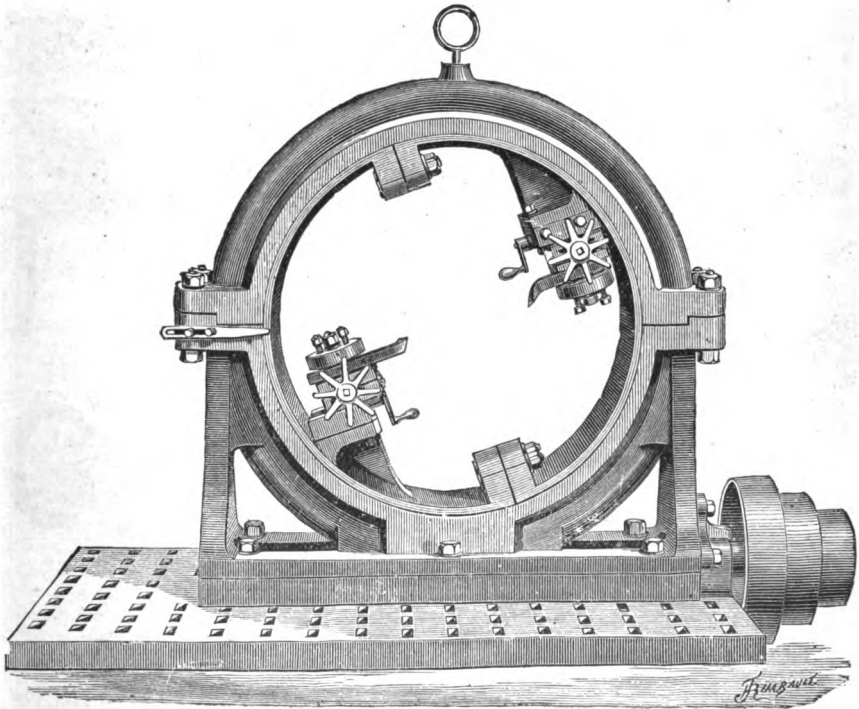

Fig. 3027

THE CRANK AXLE TURNING MACHINE, Fig. 3027, has been specially designed for turning the journals of the heavy crank shafts of marine and other large engines, the crank remaining at rest secured to the bed plate whilst the tools are revolving around and turning or truing the journal. The labour and expense of chucking these heavy masses out of centre (even when a suitable lathe is available) is thus avoided and this handy little tool has often repaid its first cost on a single job. The machine consists of a strong cast iron bed plate, planed on the surface and having a number of holes cast in it for use in bolting the work down. The faced pedestal is secured to this base plate and supports a strong cast iron ring in halves, bored internally and fitted with a turned ring—all made in halves—which carries one, two, or three compound slide rests, as required, and is caused to revolve within the outer ring, by tangent wheel and worm on the short shaft driven by the speed cones.

The machine can be made to suit almost any work, but the prices given below are for the size usually made and they include fast and loose driving pulleys, cone countershaft, hangers for same, screw keys, &c.

PRICES OF CRANK AXLE TURNING MACHINE, Fig.

Diameter of crank pin that can be turned	21 in.
Length of journal that can be turned	18 in.
Price with one slide rest	£75 0 0
Price with two slide rests	£85 0 0
Price with three slide rests	£95 0 0
Approximate weight with one rest tons	2½

BOILER END TURNING LATHE (not illustrated) will face the edges of flanged end plates, or those of angle iron rings connecting the flues with the end plates, and will cut out the holes for flue tubes. The table is cylindrical and is made to revolve horizontally by worm and wheel gear between two standards, and is spanned by a massive cross slide which carries two saddles, each with a cross bar and cutter head. The motions are self-acting and the machine, which takes plates of any diameter up to 8 ft. 6 in., will face the edges of the plates, or cut out two flue holes for a Lancashire boiler at the same time. The price of the machine with overhead motions and screw keys is £325, and the approximate weight is 10 tons. The cost of packing for shipment and delivery f.o.b. is 5 per cent.

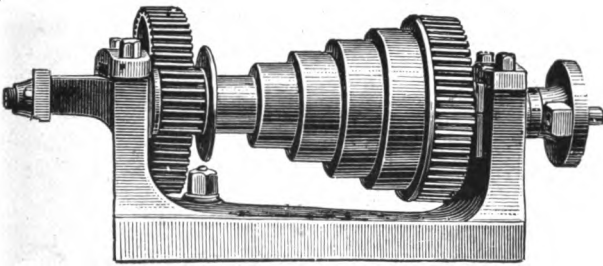

Fig. 3029 A



Fig. 3031.

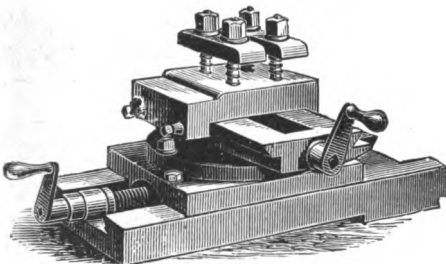

Fig. 3030.

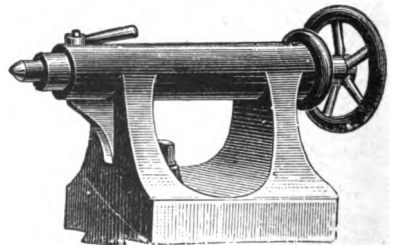

Fig. 3029 B.

LATHE ACCESSORIES are sometimes required for additions or alterations to existing tools, and for this reason the subjoined list of prices is given, but wherever these form part of a machine they are included in the foregoing prices of complete tools.

PRICES OF LATHE ACCESSORIES, FIGS. 3029 A AND B, 3030 AND 3031.

Size of lathe (height of centres)	5	6	7	8	9	10	12
Double geared fast and loose headstocks, Figs. 3029 A & B with top motion, per pair	£7 15	£9 10	£12 10	£16 10	£20 5	£22 10	£31 10
Single speed, ditto ditto with top motion ...	£6 5	£7 15	£9 10	£11 15	£14 15	£15 15	£22 10
Compound slide rest, Fig. 3030	£4 10	£6	£6 15	£7 10	£9 15	£12	£16
Eccentric hand rest, Fig. 3031	£1 10	£1 19	£1 19	£2 6	£2 6	£2 15	£3 2



PRICES OF LATHE CARRIERS WITH STEEL SCREWS.

Span in.	½	¾	1	1¼	1½	1¾	2	2½	3	3½	4	5	6
Price ..	4/-	4/6	5/6	7/6	9/6	11/-	14/-	17/-	21/6	24/-	28/-	35/-	42/-

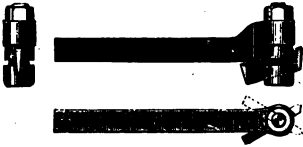

PRICES OF SWIVEL TOOL HOLDERS.

Depth of cutter ... inch	½	¾	1	1¼	1½	2	3
Price ..	18/9	25/-	31/-	40/-	50/-	65/-	100/-
Special steel cutters, per doz.	7/6	10/6	17/6	22/-	35/-	68/-	142/-

PRICES OF CHANGE WHEELS.

Pitch of teeth ...	½	⅝	¾	1	1½
Breadth of ditto ...	1 in.	1 in.	1¼ in.	1½ in.	1¾ in.
Price of set of 22 wheels, 20 to 120 teeth, bored, turned, and cleaned, key-ways cut, &c.	£2 10	£3 10	£5 10	£8	£13 10
Price of same, with machine cut teeth ...	£7 10	£8 10	£11	£20	£32

SPECIAL CAST STEEL TOOLS for sliding, surfacing, or boring tools of the ordinary shapes are supplied in sets at the following prices:—

From 1¼" square steel	...	1/2 per lb.
" 1" "	...	1/4 "
" ¾" "	...	1/6 "
" ½" "	...	1/7 "

Packing for shipment and delivery f.o.b. will cost from 5 to 8 per cent. on the value of above tools.

THE FOUR JAW CHUCKS, illustrated, known as the independent (Figs. 3032 and 3034), and the universal (Fig. 3033) chucks, are the types generally preferred; Fig. 3032 shews an independent chuck with reversible jaws, and Fig. 3034 a similar chuck but with plain jaws. The universal chuck Fig. 3033, is fitted with ordinary jaws, and this type will be found very useful where finished work has to be rechucked.

All chucks are made of the best material, fitted perfectly true, and the jaws are case hardened; the screws are of steel, accurately cut, and a box key is provided with each chuck.

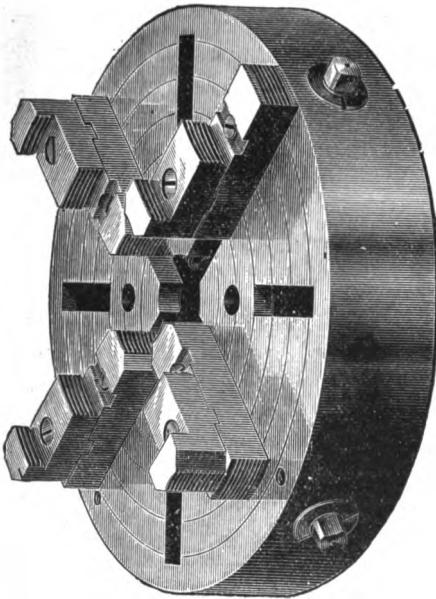

Fig. 3032.

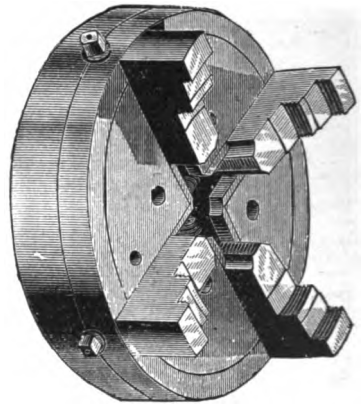

Fig. 3033.

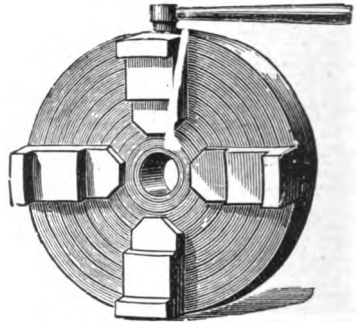

Fig. 3034.

PRICES OF FOUR JAW INDEPENDENT CHUCKS, Figs. 3032 & 3034.

Size of lathe	3in.	4in.	6in.	7½in.	9in.	10½in.	12in.	15in.	18in.	21in.
Diameter of chuck	6in.	9in.	12in.	15in.	18in.	21in.	24in.	30in.	36in.	42in.
Price with plain jaws, { Fig. 3034	£3	£4	£5.12	£7	£8.10	£10	£11.10	£14	£17	£20
Price with reversible jaws, { Fig. 3032	£4.8	£5.8	£6.15	£8	£10.5	£12.10	£15	£23	£34	£56

PRICES OF FOUR JAW UNIVERSAL CHUCKS, Fig. 3033.

Size of lathe	5in.	6in.	7in.	8in.	9in.	10in.	12in.
Diameter of chuck	10in.	12in.	14in.	16in.	18in.	20in.	24in.
Price	£6.5	£7.10	£8.15	£10	£11.5	£12.10	£15

PRICES OF EIGHT SCREW BELL CHUCKS, FIG. 3035.

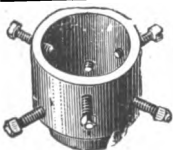

Fig. 3035.

Size of lathe	5in.	7in.	9in.	10in.	12in.	14in.
To admit	3in.	4in.	5in.	6in.	7in.	8in.
Price	28/6	37/6	45/-	50/-	60/-	75/-

The cost of packing for shipment and delivery f.o.b. is 6 per cent.

MILLING MACHINES turn out work with such accuracy, and effect so great a saving in time and in the cost of producing work, hitherto done by manual labour or on planing, shaping, or slotting machines, that they must be regarded as essential in the equipment of all works where the above named conditions are valued.

Many types are made which cannot now be referred to, but that illustrated and described is in general use for shaping out pieces very varied in size and shape. The same machine —when provided with the necessary accessories, the cost of which will be found below—is profitably employed in cutting the teeth of spur and bevil wheels, channeling parallel, or taper taps or rhymer, cutting twist drills, making milling machine cutters with straight or helical teeth, &c. Machines to do accurate work, so varied in character, must evidently be constructed with great care and be well fitted and finished.

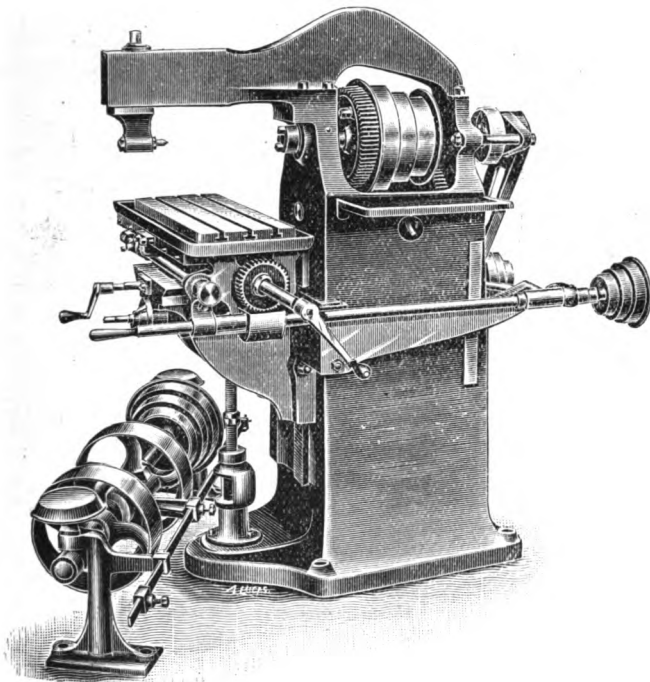

Fig. 3036.

UNIVERSAL MILLING MACHINE.—Fig. 3036 represents with sufficient accuracy, the type which is available for all the operations above referred to. The driving gear and the projecting arm with adjustable centre to support the outer end of the cutter spindle, are secured to a strong standard of box section, as shown.

The wheels in the double geared machines are machine cut, and the automatic feed to the table is driven by a belt, which adjusts itself to varying heights of the table, and is provided with the necessary self-acting tightening apparatus.

The table is adjustable to any height within the limits indicated in the following list, and an automatic stop motion regulates the traverse of the table. Each machine is complete with a specimen cutter spindle, overhead motions, screw keys, &c.

PRICES OF UNIVERSAL MILLING MACHINES, Fig. 3036.

To take in under spindle	13in.	15in.	18in.
Longitudinal traverse of table... ..	9in.	20in.	24in.
Cross feed of table	3½in.	5in.	9in.
Price of machine, single speed... ..	£45	£63	...
Ditto ditto double ditto... ..	£50	£68	£105
Approximate weight tons	¾	1	2

The cost of packing for shipment and delivery f.o.b. is 5 per cent.

Size of machine	13in.	15in.	18in.
Parallel vice with swivelling base	£3 15	£4	£5
Apparatus for milling spiral cutters, rhymer, twist drills, &c., with dividing head and change wheels }	£18 10	£22	£30
Stay for cutting twist drills	£3	£4	£4 10
Poppet head for taper work	£2 10	£2 15	£3 10
Ditto ditto straight ditto	£2 7 6	£2 10	£3

The cost of packing for shipment and delivery f.o.b. is 5 per cent.

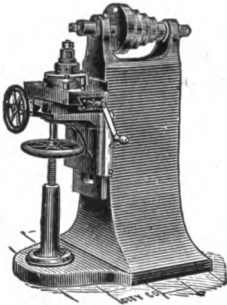

Fig. 3037.

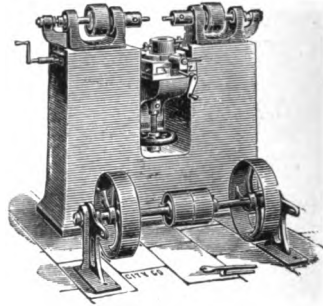

Fig. 3038.

MILLING MACHINES, illustrated by Figs. 3037 and 3038, are specially adapted for rapidly and accurately finishing almost all kinds of light work and, where a large number of surfaces have to be shaped, these tools perform the work with great economy in time and in cost.

THE SINGLE MILLING MACHINE, Fig. 3037, consists of a box standard with a planed V slide in front, which carries the table, adjusted in height by the vertical screw and hand wheel in front of the machine. The table has planed T slots for fixing the work, and it is provided with compound slides which give longitudinal and transverse traverse. The spindle is of steel and works in hard gun metal bushes. The standard forms a cupboard (with door) for cutters and other tools, and each machine is complete with dividing apparatus for 4, 6, or 8 sided objects, one large cutter, overhead motion, &c.

The dimensions and prices of the machine are:—

Traverse of table each way	7 in.
Traverse of table in height	9 in.
Pulley on top shaft	12 in. x 2½ in.
Price of the machine	£26 0 0
If with overhanging arm to support the cutter spindle on both sides	£28 10 0
Approximate weight	12 cwt.

Cost of packing for shipment and delivery f.o.b., 5 per cent.

DOUBLE MILLING MACHINES, see Fig. 3038, differ slightly from those last described, the heads being adjustable so that they can be fixed in the position required for finishing both sides of an object with one setting. The table has one vertical and one horizontal movement, the adjustment of the heads supplying the other horizontal movement found in the single machine.

The dimensions and prices are—

Traverse of table horizontally	6 in.
Traverse of table in height	8 in.
Traverse of heads between spindles	8 in.
Price of the machine	£40 0 0
If with overhanging arms to support the cutters on both sides	£46 0 0
Approximate weight	15 cwt.

Cost of packing for shipment and delivery f.o.b., 5 per cent.

SPIRAL, ANGULAR, AND STRAIGHT MILLING CUTTERS are illustrated by Figs. 3039 to 3041, and are adapted for all kinds of ordinary and irregular shaped work. The former are generally used to finish flat or plain surfaces, and the latter for the various parts of sewing machines, gun work, &c.

When the cutters require sharpening, the faces of the teeth are ground on a special machine referred to at page 93; this operation can be repeated many times without altering the shape of the teeth, which is a valuable feature, because it saves the cost of annealing the tool, recutting and rehardening it.

Cutters 1 inch wide and upwards, for milling straight work, have teeth of spiral form; the effect of this is to produce an extremely smooth surface and to consume very little power.

The cost of the cutters in general use will be found in the following lists, but tools for special purposes are supplied on receipt of a sample, tracing or template of the cutter required, or of a tracing and description of the work to be done, also the diameter of the hole in the cutter.

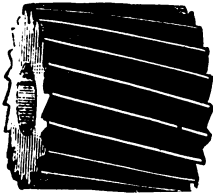

Fig. 3039.

PRICES OF SPIRAL CUTTERS, Fig. 3039.

Width .. ins.	1	1½	2	2½	2¾	3	3½	4
Diameter ..	1½	1½	2	2½	2¾	3	3	3
Dia. of hole ..	⅝	⅝	⅝	⅞	⅞	⅞	1⅛	1⅛
Price each	12/-	16/6	22/-	35/-	40/-	45/-	50/-	55/-

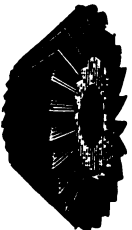

Fig. 3040.

PRICES OF ANGULAR CUTTERS, Fig. 3040.

Width	ins.	½	⅝	¾	1
Largest diameter	1½	2½	2¾	3½
Diameter of hole	⅝	⅞	⅞	1⅛
Price	each	12/-	15/6	18/6	35/-

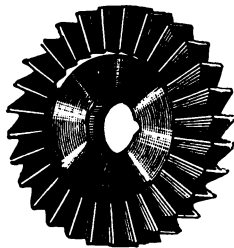

Fig. 3041.

PRICES OF SIDE EDGE CUTTERS, Fig. 3041.

Width .. ins.	½	¾	1	⅝	¾	7/8	1	1½
Diameter ..	1½	2	2½	2¾	3	3½	3½	4
Dia. of hole ..	⅝	⅝	⅝	⅞	⅞	⅞	1⅛	1⅛
Price .. each	11/-	12/-	15/-	17/6	25/-	30/-	40/-	50/-

The cost of packing for shipment and delivery f.o.b. varies, but for quantities it does not exceed 5 per cent.

SPECIAL MILLING CUTTERS are supplied on receipt of the particulars referred to above.

WHEEL CUTTING AND DIVIDING MACHINE.—Although the teeth of wheels, &c. may be cut in a shaping or milling machine, it is found more convenient and economical to use a separate machine specially designed to cut spur, bevel, mortice, or worm wheels, in wood, brass, or iron.

The spindle used for cutting iron or brass is different from that for cutting wood, the former being double geared whilst the latter has a single speed. The wheel to be cut is securely fixed to a horizontal mandril, having a machine cut dividing worm wheel keyed on it; the worm is of steel and in two parts, with adjusting nuts to take up the wear of the threads. The saddle which carries the wheel to be cut is adjustable on the bed, to suit wheels of different sizes; the cutter slide has a self acting variable feed motion and can be set to any angle for cutting bevel or worm wheels. Each machine is complete with overhead

motion, having a compensating arrangement for tightening the cord; it is also fitted with a full set of machine cut change wheels, one cutter spindle for wood and one for iron, one sample cutter for each material, screw keys, &c. If desired, these machines can be made to cut racks, for instance, the 4 ft. machine will cut racks 3 ft. long by 4 inches broad, at an extra cost of £18.

PRICES OF WHEEL CUTTING AND DIVIDING MACHINES.

To cut wheels up to a diameter of	2ft.	4ft.	6ft.
Ditto ditto to a width of	6in.	8in.	12in.
Price	£78	£112	£135
Approximate weight tons	1½	1½	1½

The cost of packing for shipment and delivery f.o.b. is 5 per cent.

GEAR CUTTERS are made upon the best principle and can be readily sharpened by a small emery wheel, without altering the form of the cutter, until the teeth are nearly ground away. Softening, filing up, and re-hardening is thus avoided.

PRICES OF CUTTERS FOR SPUR WHEELS.

Pitch of teeth	ins.	¼	⅕	⅜	½	⅝	¾	⅞	1	1¼
Diameter of cutter	"	2½	2½	2½	2½	3	3½	3½	4	4½
Diameter of hole	"	¾	⅝	⅝	⅝	1	1	1	1	1½
Price	"	18/-	20/-	24/-	27/-	30/-	40/-	52/-	65/-	87/-

Eight Cutters are made for each pitch.

No. 1 used to wheels from 135 teeth to a rack	No. 5 used to wheels from 21 teeth to 25 teeth
" 2 " " 55 " 134 teeth	" 6 " " 17 " 20 "
" 3 " " 35 " 54 "	" 7 " " 14 " 16 "
" 4 " " 26 " 34 "	" 8 " " 12 " 14 "

Wood Cutters 5/6 each.

CUTTERS FOR WORM AND BEVEL WHEELS.—Orders for these should be accompanied by the undernamed information:

WORM WHEELS.—The number of teeth in the wheel.
The diameter of the worm, and
The number of threads to the inch.

BEVEL WHEELS.—The coarsest pitch to be cut.
The number of teeth in each wheel, and
The width of the teeth.

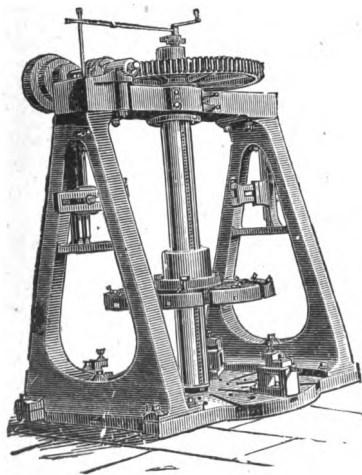

Fig. 3043.

BORING MACHINES are so often made to fulfil special conditions that reference can be made only to those which are adapted for miscellaneous work, and the Author may here mention that his experience leads him to think that these machines turn out accurate work at a lower cost than tools habitually used and that they are less appreciated than they might be.

THE VERTICAL BORING MACHINE, Fig. 3043, is specially adapted for boring large diameters and lengths, such as steam cylinders, with great accuracy and economy, and it has the further advantage that it occupies less floor space than any other tool which will do the same work.

The engraving represents the smallest sizes of the machines referred to, but larger sizes are made, of similar design and for almost any dimensions of work.

The standards are carried on a massive base plate with holes and grooves for bolting down the work and three radial arms for securing same. The boring bar with feed gear and cutter block, is driven by worm and wheel and speed pulley, as shown.

If the machine is provided with its own engine, the extra cost of which will be found below, the work can be carried on continuously with great advantage in regard to both accuracy and economy.

PRICES OF VERTICAL BORING MACHINES, FIG. 3043.

To bore in diameter	5 ft.
Ditto in length	5 ft.
Price of machine	£180
Approximate weight	7 tons
Price if with special engine	£215
Approximate weight	7½ tons
Extra for radial slide rest	£12

The cost of packing for shipment and delivery f.o.b. is 5 per cent.

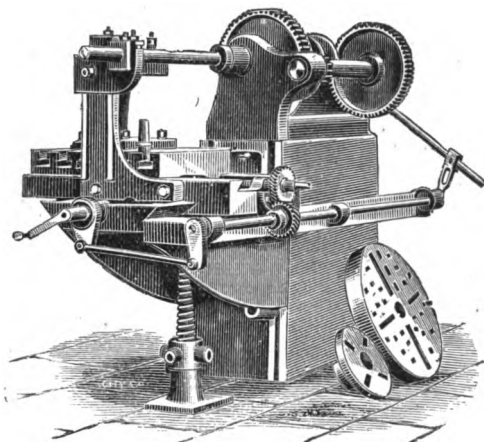

Fig. 3044.

The cost of packing for shipment and delivery f.o.b. is 5 per cent.

HORIZONTAL BORING AND FACING MACHINES

are constructed for performing many operations such as boring steam cylinders of moderate dimensions, boring and facing bearings, dynamo and other frames, &c. In all cases the tables have T slots or other arrangements for securing the work to be done and are adjustable vertically or horizontally or in both directions. The engraving, Fig. 3044, represents a machine which will bore any diameter up to 24 inches and any length up to 4 feet. The table to which the work is attached is adjustable and held perfectly steady in any desired position, the boring bar has a self-acting feed and carries two or more cutter blocks.

The price of this machine with one self-acting boring bar, one cutter head, cone pulley, overhead driving gear, screw keys, &c., is ... £110 and the approximate weight is 3 tons.

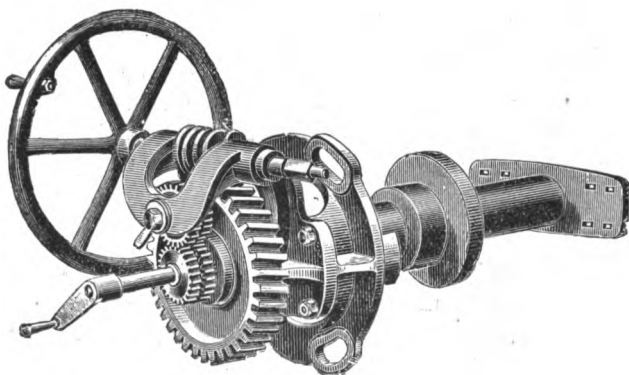

Fig. 3045.

THE PORTABLE BORING MACHINE, Fig. 3045, will bore locomotive or other cylinders, without dismounting them, and is a useful adjunct to the crank axle turning machine, Fig. 3035.

The boring bar is carried on two brackets which are bolted to opposite ends of the cylinder and the machine is worked by hand by the large wheel as shown, or this is replaced by a strap pulley if other power is available. The machine is complete with self-acting feed motion for boring cylinders 30 inches long and 20 inches diameter, one boring head, screw keys, &c.

The price of this machine is £40, and the weight is about 11 cwt. The cost of packing for shipment and delivery f.o.b. is 6 per cent.

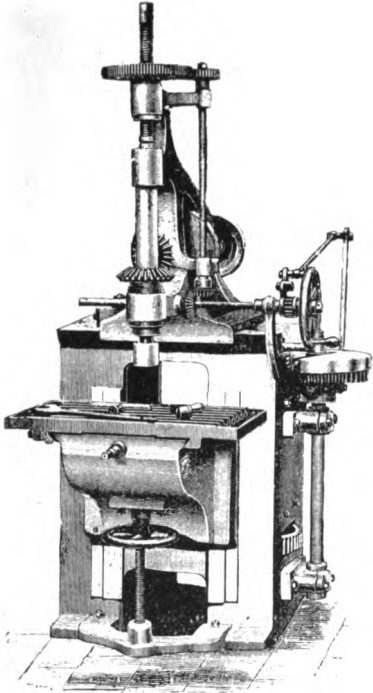

Fig. 3042.

SLOT DRILLING AND KEYWAY CUTTING MACHINE.—The engraving, Fig. 3042, represents a type of machine which deservedly occupies a high position amongst labour saving machines, by reason of the rapidity and accuracy with which it cuts seatings for keys or feathers in shafts, cotter holes in crossheads, piston rods, connecting rod ends, &c.

The end of the drill is ground flat, a small piece is taken out of the centre, and, being fixed vertically in the spindle, the lubricant remains in the slot and admits of the drill being run at a high speed without softening the tool.

The drill head has an adjustable self acting traverse, and when it reaches the point for which the traverse has been adjusted, a quick reverse motion comes into operation; the drill is automatically advanced for the next cut and so completes the seating of any dimension within the capacity of the machine. The spindle is carried in a conical bearing which has an adjustable gun metal bush for taking up wear and insuring accurate work.

The table has planed T slots to which the work is secured, and screws are provided for adjustment horizontally or vertically, to the position desired.

The machine is complete with overhead motions and screw keys, and a sample drill, and it has a horizontal traverse of 12 in. ; vertical traverse of 8 in. ; steel spindle 2 in. diameter; and will cut keyseats or cotter holes of any width up to 1½ in.

The price of the machine is £64.

The approximate weight is 1½ tons and the cost of packing for shipment and delivery f.o.b. is 5 per cent.

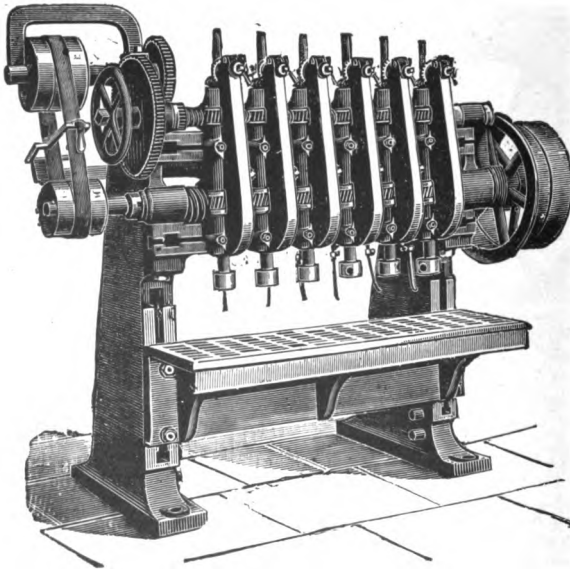

Fig. 3046 a.

MULTIPLE DRILLING MACHINES, Fig. 3046A.—These consist of a massive table with T slots to which the work is secured, a pair of standards at the ends of the table, and a strong cross slide bolted to the standards to carry the drills. In some cases the table is fixed whilst, in others, the height is varied and adjusted by screw, as shown in Fig. 3046A, or by worm and screw gear, and this arrangement is specially valuable if the work varies much in dimensions, shape, &c.

The drill spindles are of steel, 2 inches diameter, and each has a feed motion—usually of 9 inches stroke—self-acting or by hand, and capable of being worked separately, all together, or in any combination. The spindles are driven by steel worms turned out of the solid and gearing with machine cut hard gun metal worm wheels. All appliances are provided for raising or lowering the drills quickly by power; or any drill may be raised or lowered separately by hand and any spindle can be instantaneously thrown out of gear. The spindles can be adjusted on the cross slide to drill holes from about 5 inches to 12 inches centre to centre, or any closer pitch is drilled by setting the spindles to twice the pitch required and moving the work after one range of holes has been drilled.

All machines are complete with fast and loose pulleys, screw keys, &c., and they are usually made in the under-named combinations:—

PRICES OF MULTIPLE DRILLING MACHINE, Fig. 3046A.

Number of spindles	4	6	12	18
Diameter of „	2in.	2in.	2in.	2in.
Vertical feed „	9in.	9in.	9in.	9in.
Price of machine with fixed table	£145	£180	£268	£390
„ „ „ adjustable table	£155	£190	£283	£405
Approximate weight tons	2	4	6	9½

The cost of packing for shipment and delivery f.o.b. is 5 per cent.

THREE SPINDLE DRILLING MACHINE to fix to a wall or timber support is a useful tool for drilling bridge or ship plates.

The pitch is adjustable from 4½ in. to 9 in., the feed is self-acting and the drill saddle can be traversed across the slide to put in a fresh set of holes without moving the work.

The price of the machine with top driving apparatus, screw keys, &c. is £118 and the approximate weight is 3 tons.

If with table 7 ft. 6 in. long by 2 ft. wide, with T slots the extra cost is £20.

Approximate weight 1 ton.

The cost of packing for shipment and delivery f.o.b. is 5 per cent.

BOILER SHELL DRILLING MACHINES are much used for miscellaneous work and a type well adapted for varying sizes and shapes is illustrated by Fig. 3046, and is constructed as follows:

A strong turned pillar is carried vertically in a pair of sockets, one of which is fixed to the floor and the other to a roof-beam or other convenient attachment, and it is provided with a radial arm which can be turned round to describe a complete circle. The machine therefore takes in work of almost any dimension and drills rivet holes through several thicknesses of plate, and angles, &c., and produces perfectly accurate work at a very moderate cost.

The radial arm extends 7 ft. 6 in. from the centre of the pillar and is connected to it by a long sleeve; it is raised or lowered by power to the position required, the final adjustments being made by hand or power gear and both motions are controlled from the end of the arm which is the position most convenient for the workman.

The drill carriage or saddle is traversed by a revolving nut and screw worked by hand from the drill saddle.

The steel drill spindle is 2½ in. diameter with a feed of 16 in., self-acting or by hand; it is carried in a long sleeve which provides the support required for accurate work and will drill or bore at any distance up to about 5 ft. 6 in. from the pillar.

A table, adjustable in height, is provided for small work and this is turned aside when it is required to admit large pieces.

The driving motion is double geared and may be fixed in almost any position, by preference in one which leaves a clear floor space around the drill.

The subjoined prices include overhead motions, screw keys, &c., and a pillar 8 ft. 6 in. long which admits of the radial arm being raised or lowered 2 ft. 6 in. or to about 6 ft 6 in. above floor level. But pillars of greater length will be supplied at the rate of £1 7s. 6d. for each foot of extra length.

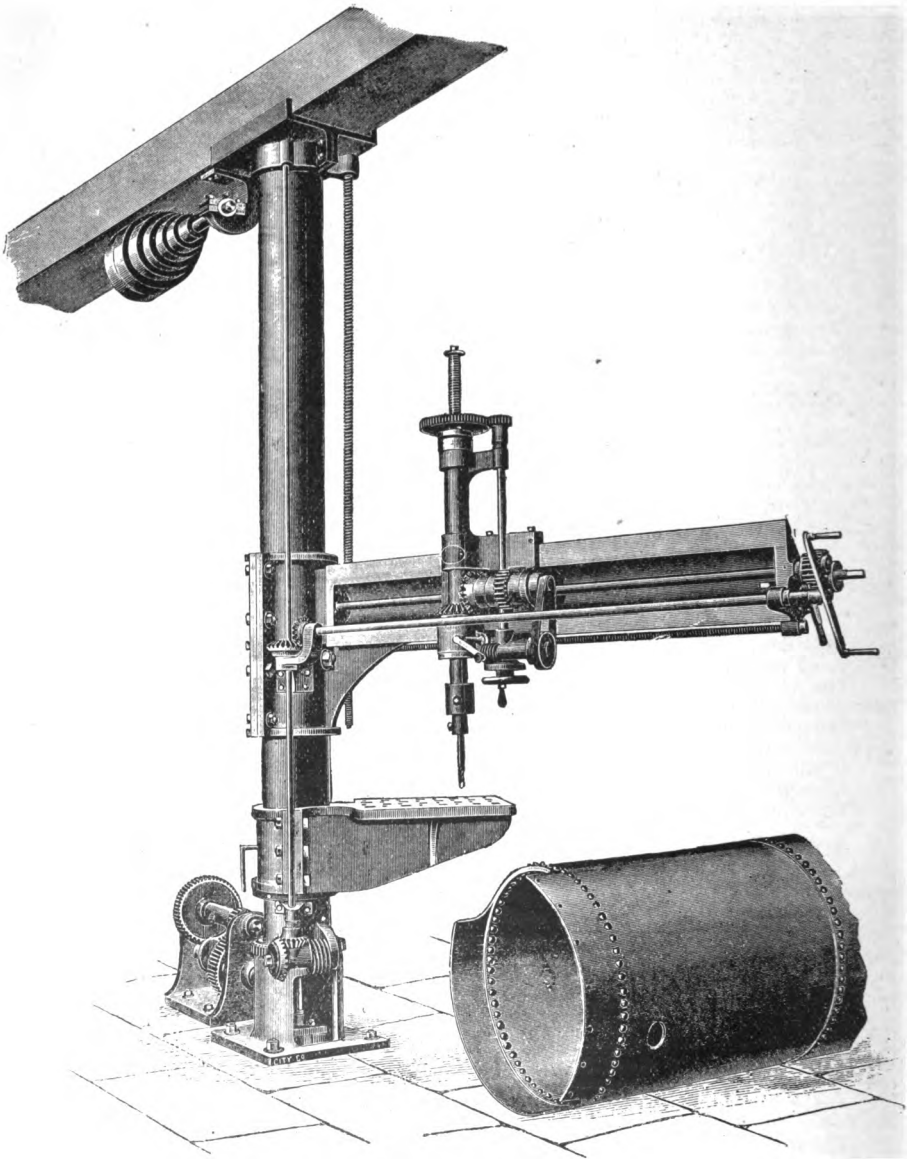

Fig. 3046

Price of Boiler Shell Drilling Machine as above described, £120.

The approximate weight is $3\frac{1}{2}$ tons.

The cost of packing for shipment and delivery f.o.b. is 5 per cent.

VERTICAL STANDARD BOILER SHELL DRILLING MACHINES.—

These machines are frequently made to fulfil special conditions but that now described is typical of all sizes and will drill up to 1 in. diameter, or bore holes for seatings, &c., in shells of any size between 3 ft. and 12 ft. diameter or, if a pair of standards are used the rivet holes in both sides of the boiler may be drilled simultaneously.

The vertical standards which are of box section, have planed surfaces against which the drill saddle slides and they are secured to a planed bed plate, which is traversed along a strong foundation plate by worm and wheel gear to adjust it to the position required for the work to be performed.

The saddle carries two drill spindles and is balanced by counter weight throughout a vertical range of 10 ft.

The drill spindles are of steel, 2½ in. diameter, with 9 in. stroke and can be adjusted horizontally for any pitch between 6 in. and 10½ in., or vertically, between 6 in. and 9 in., so that both drills can work on the horizontal or on the vertical seams; the lower drill can also be adjusted to drill at an angle pointing towards the centre of the boiler. Each spindle is self-acting in every position and can be worked separately or together.

A platform for the operator is attached to, and is carried on the drill saddle so that he always remains in the same position relatively with his work, and has complete command of the handles which control the different motions.

A circular table is provided for securing the boiler shells in position and this is rotated on rollers by worm and wheel gear, or by a hand wheel which moves up and down with the drill saddle. The machine is provided with fast and loose pulleys attached to the foundation plate, screw keys, &c.

The price of the machine with one standard and two drills is £185.

The approximate weight is 6½ tons.

The price of double standard machine with four drills is £345.

The approximate weight is 12 tons.

The cost of packing for shipment and delivery f.o.b. is 5 per cent.

DUPLIX BOILER SHELL DRILLING MACHINES are used principally for putting in the rivet holes of marine or other large boilers, in a horizontal position.

The work is supported by rollers on which it is rotated and is placed between two beds, one of which is movable for the purpose of adjusting the space to suit the different diameters of shells or flues. Both of these beds are provided with a column similar to that of a radial drilling machine, Fig. 3047, and each column carries a balanced drill saddle with two spindles which can be worked separately or in combination. The machine has powerful gear and is adapted for work varying from 3 ft. to 16 ft. diameter, and for drilling up to 1½ in. diameter, boring pipe seatings, mud holes, &c. The drill spindles have self-acting feed motions and are adapted for tapping.

The subjoined approximate prices refer to the machine above described and special quotations will be furnished for tools differing from it in arrangement or dimensions.

The price of the machine with two columns and four drill spindles is £430.

Do. do. four do. eight do. £510.

The approximate weights are respectively, 20 and 23 tons.

The cost of packing for shipment and delivery f.o.b. is 5 per cent.

THE RADIAL DRILLING MACHINES referred to below, are made to suit various requirements and consist generally of a strong column bolted to a low foundation plate, having a planed face on one side of the column upon which the arm slides, with a radiating movement through an arc of 190°. The drill carriage and spindle are also as described above in the smaller machines; the base plate is provided with T slots and upon it is bolted a loose box table having planed T slots for bolting small work to.

Each machine is complete with driving motion, screw keys, &c.

PRICES OF RADIAL DRILLING MACHINES AS ABOVE.

Length of arm	6 ft.	8 ft.
To bore at a radius of	5 ft. 4 in.	7 ft. 4 in.
Arm to raise and lower on the pillar	2 ft. 6 in.	3 ft. 3 in.
Traverse of head on arm	4 ft.	6 ft.
Vertical range of feed	1 ft.	1 ft. 4 in.
To admit in depth from foundation plate to spindle nose ..	1 ft. 4 in.	1 ft. 8 in.
Length of base plate	6 ft.	9 ft.
Width of ditto	2 ft. 9 in.	3 ft. 6 in.
Height of ditto	2 ft. 6 in.	2 ft. 8 in.
Diameter of spindle	2½ in.	3½ in.
Price of machine	£160	£239
Approximate weight tons	4	7

Packing for shipment and delivery f.o.b. costs 5 per cent.

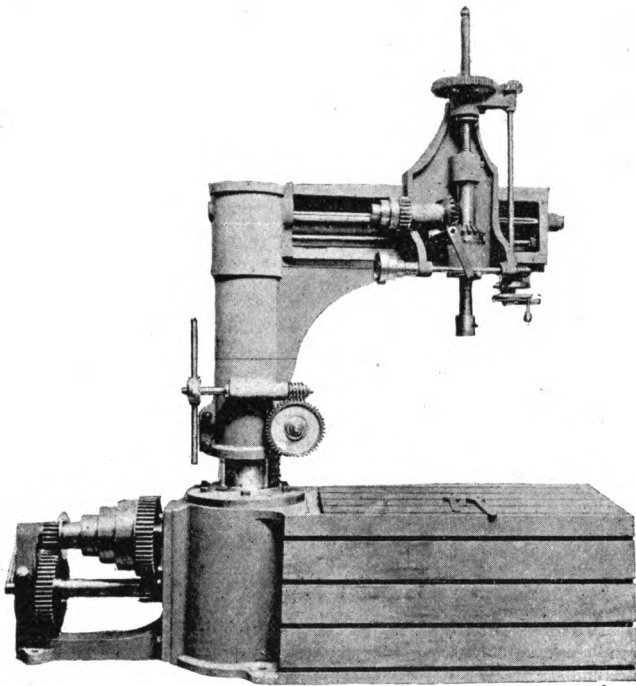

Fig. 3047.

PRICES OF RADIAL DRILLING MACHINES, FIG. 3047.

Length of arm	3 ft. 6 in.	4 ft. 6 in.
To bore at a radius of	3 ft.	4 ft. 1 in.
Arm to raise and lower on the pillar...	1 ft. 2 in.	1 ft. 6 in.
Traverse of head on arm	1 ft. 6 in.	2 ft. 2 in.
Vertical range of feed	1 ft.	1 ft. 6 in.
To admit in depth from bed to spindle	3 ft. 6 in.	4 ft.
Length of Box Base	4 ft. 9 in.	6 ft. 5 in.
Width ditto	2 ft. 4 in.	2 ft. 9 in.
Height ditto	2 ft. 4 in.	2 ft. 2 in.
Diameter of spindle	2 in.	2½ in.
„ „ pillar	8 in.	9 in.
Price of machine... ..	£60	£80
Approximate Weight tons	2	2½

The cost of packing for shipment and delivery f.o.b. is 5 per cent.

DOUBLE GEARED RADIAL DRILLING MACHINES of the type Fig. 3047, consist of a strong box base of the dimensions given above, the top and one side being provided with planed T slots for fixing the work to either, as may be most convenient. A massive turned post is secured to the base and carries the revolving arm, as shown in the engraving.

The height of the arm is regulated by worm gear and it will describe any portion of a circle when in any position, the ample surfaces bearing against the pillar insuring great stability when the drill is at work.

The drill carriage or saddle is caused to slide along the arm by means of a revolving nut carried on a fixed screw which is worked by a handle placed near to the drill spindle, thus affording a quick traverse and fixing the drill in position for work.

The drill spindle is of steel and is fitted with a self-acting variable feed motion, with instantaneous disengaging gear, which is not affected by the weight of the cut put on. The driving motion is transmitted to the spindle from a wheel which is connected to a long sleeve with hard gun metal bearings, and this, as well as the hardened steel end of the drill spindle, has adjusting nuts for taking up wear.

The subjoined prices include overhead motions, screw keys, &c.

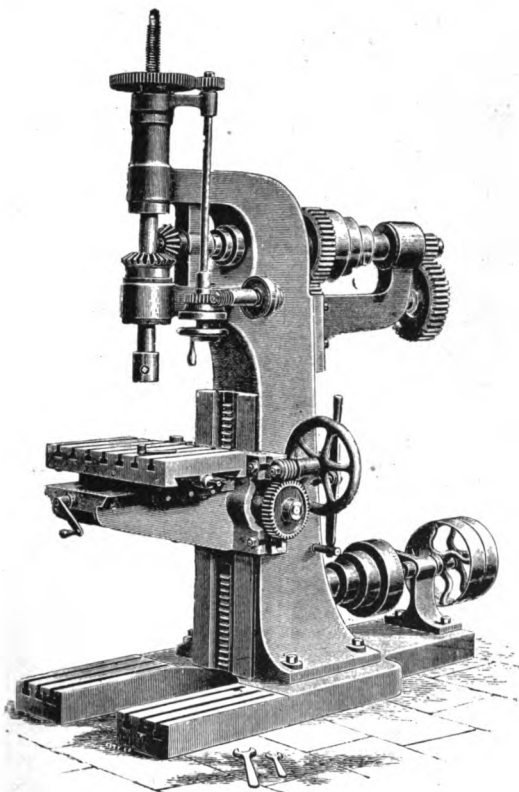

Fig. 3048.

DOUBLE GEARED STANDARD DRILLING MACHINE, Fig. 3048.—The standard is of box section and is fixed on a massive base plate planed on the surface and provided with T slots for securing large objects; the proportions throughout are such as are required for heavy and accurate work.

The table is bolted to a saddle which fits the planed slide in front of the standard, and is moved vertically by a hand wheel and worm gear. The compound slide, shown in the engraving, admits of the work being adjusted without removing it, and a strong hinged connection on one side of the machine allows the table to be swung clear, for fixing to the base plate pieces too large to be carried on the rising and falling table.

The steel spindle is well supported, the boss of the wheel through which it passes being bored conically and fitted with a hard gun metal bush with adjusting nuts to take up wear.

The self-acting feed motion can be instantly disengaged and will not stick whatever may be the weight on the drill.

The driving motion, including the four speed cones, fast and loose pulley, guide for main driving belt, &c., are carried on the machine and it is entirely self contained.

PRICES OF DOUBLE GEARED DRILLING MACHINES, FIG. 3048.

To admit in diameter	2 ft. 6 in.	3 ft.	3 ft. 6 in.
Diameter of steel spindle	2 in.	2½ in.	2½ in.
To bore holes any depth up to	10 in.	12 in.	12 in.
Ditto ditto diameter up to	5 in.	8 in.	8 in.
To admit in depth between spindle and table	2 ft.	2 ft. 4 in.	2 ft. 4 in.
Ditto ditto ditto and base	3 ft.	3 ft. 4 in.	3 ft. 4 in.
Price	£55	£62	£67
Extra for set of twist drills	£7	£10	£10
Approximate weight cwts.	28	34	37

The cost of packing for shipment and delivery f.o.b. is five per cent.

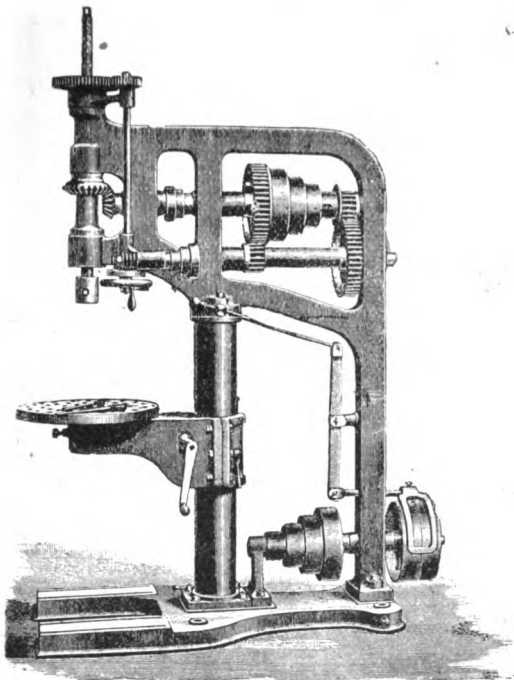

Fig. 3049.

PRICES OF DOUBLE GEARED DRILLING MACHINES, FIG. 3049.

To admit in diameter	2 ft. 6 in.	3 ft.	3 ft. 4 in.	3 ft. 6 in.
Diameter of table	1 ft. 8 in.	2 ft. 8 in.	2 ft. 10 in.	3 ft.
Diameter of steel spindle	2 in.	2½ in.	2½ in.	2½ in.
To admit in depth from top of table ...	2 ft. 8 in.	2 ft. 4 in.	2 ft. 4 in.	2 ft. 4 in.
To admit in depth from foundation plate...	3 ft. 8 in.	3 ft. 10 in.	3 ft. 10 in.	3 ft. 10 in.
To bore holes, depth	10 in.	12 in.	12 in.	12 in.
Ditto diameter	5 in.	6 in.	6 in.	6 in.
Price with conical bearings	£36	£43	£48	£53
Extra for set of twist drills... ..	£7	£10	£10	£10
Approximate weight cwt.	20	27	30	32

Packing for shipment and delivery f.o.b. is five per cent.

SINGLE SPEED PILLAR DRILLING MACHINES are made of the same type and dimensions as the first size (2ft. 6in.) Fig. 3049.

This machine will bore any size up to 2in. diameter and 10in. deep and the price is £27 10s. The approximate weight is 15 cwt. and the cost of packing for shipment and delivery f.o.b. is five per cent.

SINGLE AND DOUBLE GEARED PILLAR DRILLING MACHINES.

The engraving, Fig. 3050, illustrates a single speed machine, but they are frequently made with double gear for boring diameters exceeding the capacity of the single speed machines.

In both cases the table is carried by a bracket, which is adjustable on a turned column by a rack and pinion, and arranged to be turned aside to admit large pieces.

The spindle is of steel and is traversed by a variable self-acting feed motion with disengaging gear, or by hand. These machines are complete with overhead motions, guide for strap, screw keys, &c.

If it is desired to work the machine by manual power, a suitable fly wheel with handle will be supplied at an extra cost of £1 10s.

DOUBLE GEARED PILLAR DRILLING MACHINES of the type Fig. 3049, are strong, well proportioned tools, suitable for general work, but they are not fitted with the compound table and other accessories shown in the preceding engraving. The table slides on the turned pillar and is adjusted in height by means of worm and wheel and rack gear, and provision is made for turning it round to clear the planed base plate, which is provided with T slots for large pieces to be attached to it.

The spindle is of steel of the dimensions given below, and it is carried in conical bearings of hard gun metal with adjustments for taking up wear. The feed motion is self-acting or by hand and has instantaneous disengaging gear of the type last referred. The machine is complete with four speed cones, fast and loose pulley, belt guide, screw keys, &c.

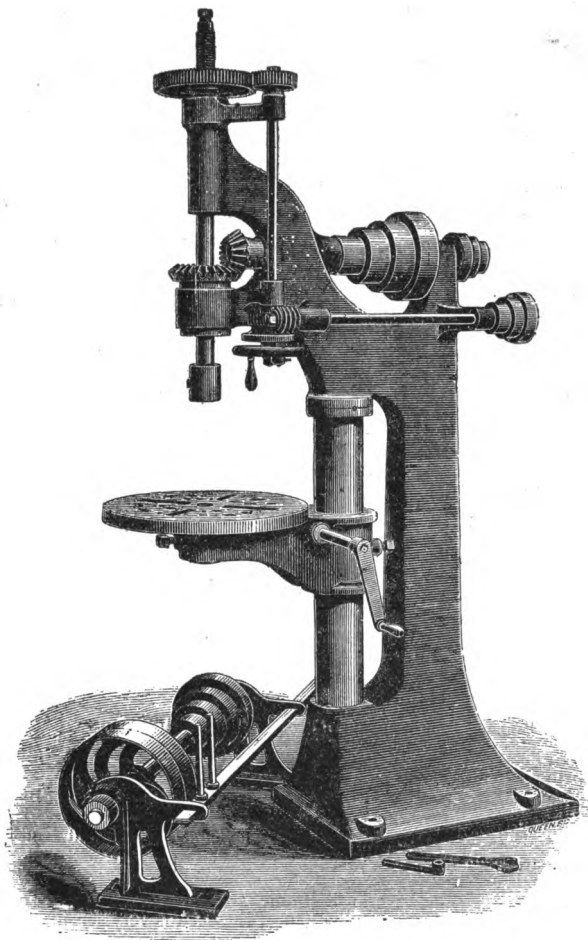

Fig. 3050.

PRICES OF DRILLING MACHINES, FIG. 3050.

To admit any diameter up to	2ft.
Diameter of table	1ft. 8in.
" of steel spindle	1½in.
To admit between table and drill spindle...	2ft. 4in.
" " " floor and "	3ft. 8in.
To bore any diameter up to	1½in.
" " " depth	8in.
Price of single speed machine	£25
To bore any diameter up to	3in.
" " " depth	8in.
Price of double geared machine	£29
Approximate weight	cwt.	12

Packing for shipment and delivery f.o.b. is 5 per cent.

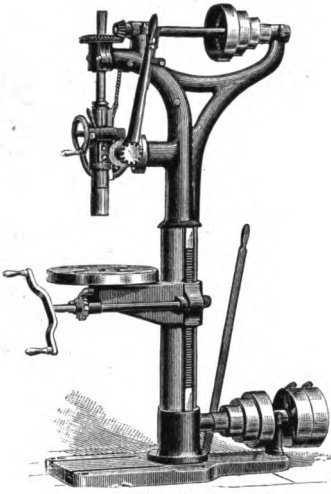

Fig. 3051.

PILLAR DRILLS WITH BALANCED SPINDLES, one type of which is illustrated by Fig 3051—originally designed and made in the United States—are now largely used in this and other countries with marked advantage in the production of accurate work, rapidly executed.

Amongst other useful and (to many) novel features in these tools, may be mentioned the system of balancing the spindle which facilitates adjustment and prevents back lash. Also the device applied to some of the machines, when specially ordered, which automatically stops the feed at any point desired and thus insures complete uniformity in the depth to which any number of holes will be drilled. Other good details are a clutch and lever for throwing in the back gear, quick return motion for drill spindle, machine cut wheels, &c. The 2ft. 4in. and 2ft. 8in. machines are double geared.

As indicated in the engraving, and by the foregoing brief description, these tools are available for a wide range of work, and are specially useful in shops where ordinary and fine drilling must be done with accuracy and despatch.

PRICES OF PILLAR DRILLS, FIG. 3051.

To admit in diameter up to	1ft. 8in.	2ft.	2ft. 4in.	2ft. 8in.
Diameter of table	1ft. 5in.	1ft. 11in.	2ft. 2in.	2ft. 4in.
„ of spindle	1 ⁵ / ₈ in.	1 ⁷ / ₈ in.	1 ⁷ / ₈ in.	1 ⁷ / ₈ in.
Admits between spindle and table ...	2ft. 2in.	3ft. 6in.	3ft. 1in.	3ft. 7in.
„ „ spindle and base plate	3ft. 5in.	4ft. 6in.	4ft. 4in.	4ft. 11in.
Price	£24	£58	£67	£79
Approximate weight cwts.	6	15	20	25

The cost of packing for shipment and delivery f.o.b. is 5 per cent.

SIX SPEED SENSITIVE DRILLING MACHINE illustrated by Fig. 3052 is capable of drilling holes up to ³/₄in. diameter, and will swing 18 inches; the smallest hole can be drilled without fear of breaking the drills, owing to its extreme sensitiveness, and to its facilities for changing the rate of speed.

The six speeds are obtained by three speed cones on a countershaft, and two speed cones on the spindle so that, by changing the two belts, great variations in the speed of the spindle can be obtained.

The spindle cone runs in a bush in the frame which takes the entire pull of the belt, and thus relieves the spindle of all side strain; hence, the feed is very sensitive and the thrust is further taken by a ball race which reduces the friction to a minimum and ensures a long life to the spindle. The spindle is counterbalanced by a chain and weight on the head of the machine; the table is also balanced by a weight in the pillar and has a quick grip lever to fix it in any position. The table has T slots with suds trough round the edge.

PRICES OF SIX SPEED SENSITIVE DRILLING MACHINE, Fig. 3052.

To drill holes up to	¾in. diameter
To admit in diameter	1ft. 6in.
Range of vertical feed	7in.
Size of table	1ft. 3in. x 1ft.
Table will lower under spindle	2ft. 6in.
Price of machine	£23
Approximate weight	5 cwts.
Space occupied	3ft. 6in. x 2ft.

The cost of packing for shipment and delivery f.o.b. is 5 per cent.

THE SIX SPEED SENSITIVE DRILLING MACHINE, Fig. 3053, fulfils similar conditions to that illustrated by Fig. 3052, but has an upper and lower table. the former for small work and when this is turned aside, the lower table, which is adjustable in height, is available for work too bulky to fix on the upper table.

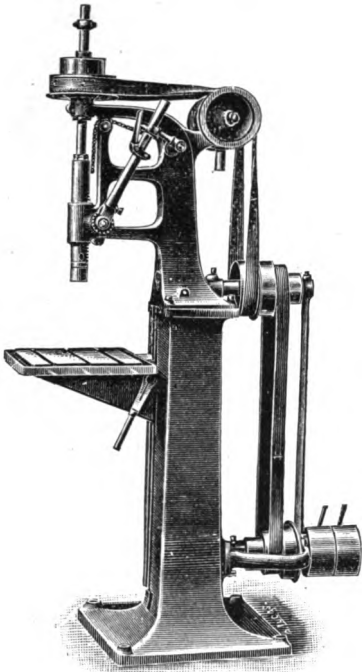

Fig. 3052.

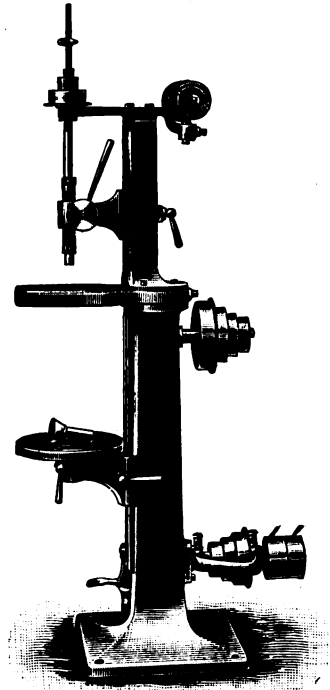

Fig. 3053.

The six speeds are obtained by using a three cone pulley on the counter shaft and a two cone pulley on the drill spindle. This wide range of speeds admits of the drill being run at the velocity most suitable to the work in hand, whether it be the smallest hole or one of $\frac{1}{2}$ in. diameter and, all motions being transmitted by belt, the work is accurate and there is very little risk of drills being broken.

The cone on the spindle revolves in a bush in the frame, and it is driven by two keys in feather key ways which relieve the spindle of strains due to the pull of the belt. The thrust is taken by a ball race.

The spindle is balanced by a coiled spring and has a hand feed motion worked by a lever and pinion gearing with a rack on the spindle casing; the rack and pinion are of steel and are machine cut.

The machine is complete with strap guide and foot lever for shifting it, screw keys, &c.

The PRICE of a machine to take in work up to 12 in. diameter and to drill holes any size up to $\frac{1}{2}$ in. diameter, in steel is, £16 10s.

The weight is about 4 cwt. and the cost of packing for shipment and delivery f.o.b. is 5 per cent.

SINGLE AND DOUBLE GEARED RADIAL WALL DRILLING MACHINES, Fig. 3054, does not accurately represent all the sizes of the machines referred to below, but it clearly indicates the general arrangement, the mode of fixing them, &c.

These machines serve very much the same purposes as the independent radial drills already described, but in this case the radiating arm is supported by a strong bracket which is secured to a wall or column and (in the latter case) whilst economising floor space, the machine can often be fixed to command both sides of the column as well as the space in front of it, and be easily driven from a line of shaft carried by the columns.

THE SINGLE GEARED MACHINES are exceedingly useful for light work and, a number of them fixed in line, have rendered good service in drilling boiler and bridge work, locomotive frames, &c.

THE DOUBLE GEARED MACHINES are available for all the work above named as well as for much heavier work if such should be required. The drill spindles are of steel, the feed motions are self-acting or worked by hand, and each machine is complete with top driving apparatus and screw keys.

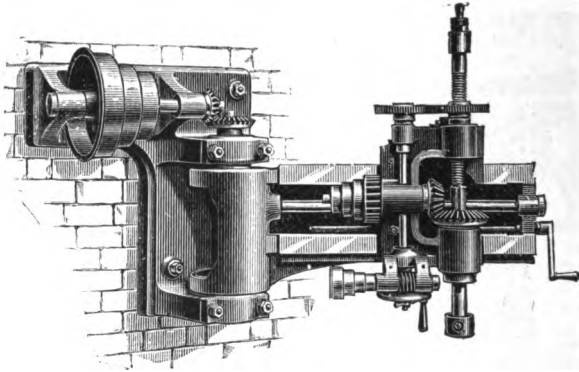

Fig. 3054.

PRICES OF RADIAL WALL DRILLS, FIG. 3054.

Radius of arm	3ft. 6in.	4ft.	4ft. 6in.	5ft.
Diameter of spindle	2in.	2in.	2½in.	2½in.
Vertical feed	10in.	10in.	12in.	12in.
Price, single speed	£49	£55	£66	£75
„ double geared	£55	£62	£75	£84
Approximate weight ... tons	1½	1½	1½	2

The cost of packing for shipment and delivery f.o.b. is 5 per cent.

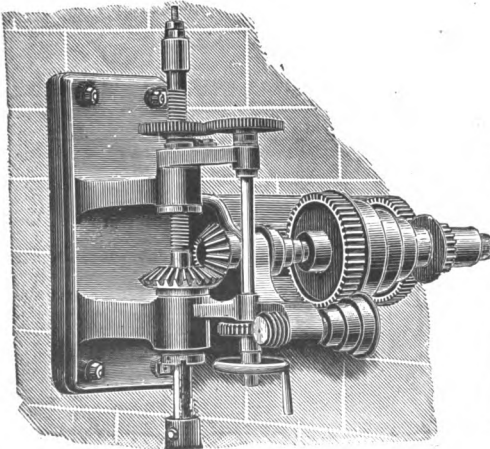

Fig. 3055.

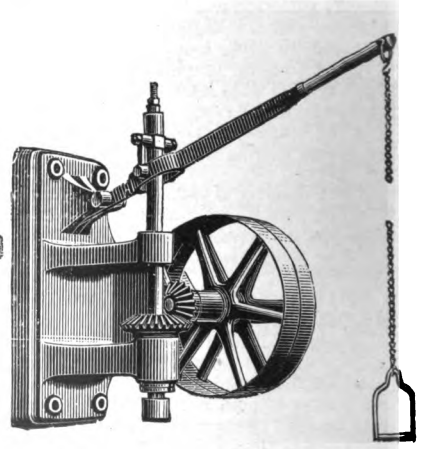

Fig. 3056.

DOUBLE GEARED WALL DRILLING MACHINES are fixed in the same manner and are available for the same purposes as those last described—see Fig. 3055—but being of heavier construction and double geared, they may also be used for much heavier work. The feed motions are self-acting and by hand and the machines are sent out complete with overhead motion, screw keys, &c.

PRICES OF DOUBLE GEARED WALL DRILLING MACHINES, FIG. 3055.

Distance from spindle to wall	1ft. 6in.	2ft.
Diameter of spindle	2in.	2½in.
Range of feed	9in.	12in.
Will bore diameter up to	6in.	8in.
Price of machine	£40	£48
Approximate weight tons	¾	1

The cost of packing for shipment and delivery f.o.b. is 5 per cent.

WALL DRILLING MACHINES.—Fig. 3056 represents a handy and compact tool, easily fixed to shop wall, column or post and as easily removed for use elsewhere. These are serviceable for light work, counter sinking, &c., or for drilling a series of holes in long pieces and (as the machine can be fixed at any height desired) it will drill work of a size which cannot be fixed under most of the machines previously referred to.

The spindle is of steel, well supported, and the feed is regulated by a hand lever which is balanced to withdraw the drill. The machine is complete with fast and loose pulley, as shown, screw keys, &c.

PRICE OF WALL DRILLING MACHINES, FIG. 3056.

Distance from spindle to wall	2ft.	1ft. 6in.	2ft. 6in.
Diameter of spindle	1½in.	2in.	2½in.
Range of feed	8in.	6in.	6in.
Width of pulleys	3in.	3½in.	3½in.
Price of machine... ..	£17	£22	£35
Approximate weight cwts.	7	10	18

The cost of packing for shipment and delivery f.o.b. is 5 per cent.

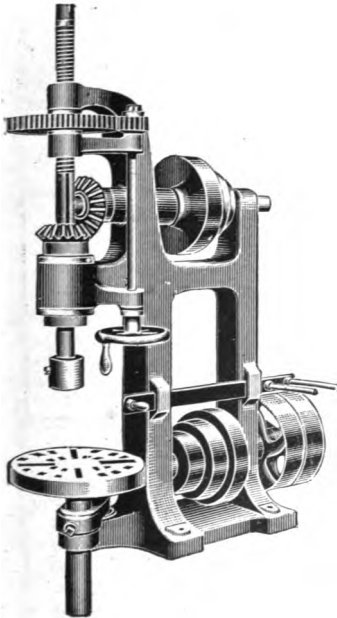

Fig. 3057.

THE BENCH DRILLING MACHINE, Fig. 3057, is adapted for fixing on a bench or on an independent cast iron stand, the latter—by preference—if the machine is provided with a fly wheel for working by manual power.

The table, as usually made, is 12 inches diameter, arranged to raise and lower, and also to swing on one side clear of the spindle: the machine admits articles up to 18 inches diameter, and will drill holes of any diameter up to 1 inch, and to a depth of 6 inches.

The machine is complete with three speed cones, fast and loose pulley, fork for moving the driving belt, screw keys, &c.

PRICES OF DRILLING MACHINES, FIG. 3057.

Price of machine complete for bench ...	£28.
„ „ on a cast iron stand ...	£32.
Extra if with self-acting motion to feed ...	£1 10s.
„ „ wheel and handle for hand power ...	15s.
„ for 9 flat drills ⅜ to ¾ ...	14s.
„ „ 9 twist drills ...	£2 10s
Approximate weight without stand cwts.	6
„ „ with „ cwts.	10

The cost of packing for shipment and delivery f.o.b. is 6 per cent.

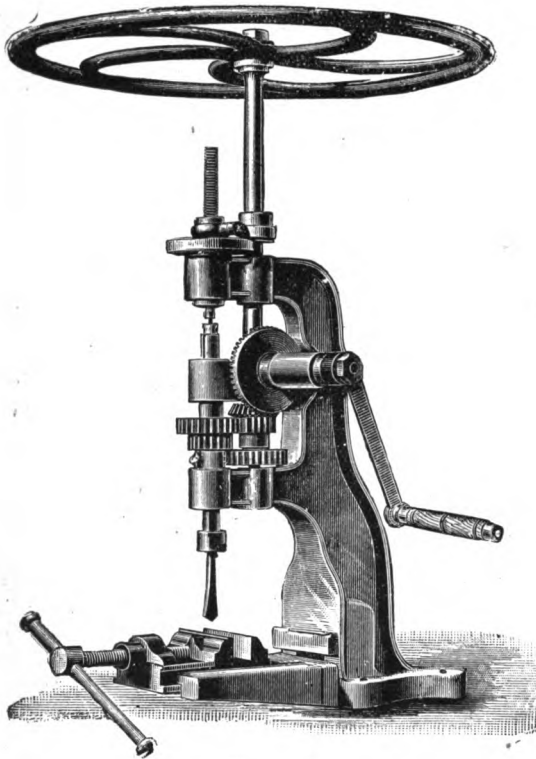

Fig. 3058.

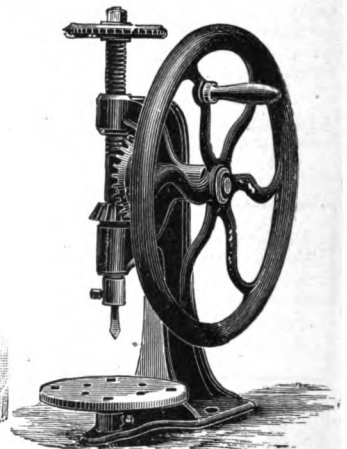

Fig. 3059.

HAND POWER BENCH DRILLING MACHINES.—The machine, Fig. 3058, has two speeds which are changed by removing a brass stop or clip, and altering the position of the spur driving gear. The feed motion is automatic or by hand, and the machine is complete with the horizontal fly wheel, parallel vice and six drills.

PRICES OF DRILLING MACHINES. FIG. 3058.

To drill up to diameter	2 in.	1 in.	1 1/2 in.
To admit beneath drill	15 in.	20 in.	23 in.
Diameter of spindle	1 in.	1 1/2 in.	1 3/4 in.
Diameter of fly wheel	28 in.	32 in.	36 in.
Price with six drills and vice	£5 10s.	£7 10s.	£10
Weight	1 3/4	2 1/4	3
Extra for fast and loose pulleys	15/-	£1	£1 10s.
" " overhead motion	£3 15s.	£4 5s.	£4 15s.
" " six twist drills	£1	£1 15s.	£2 10s.

Packing for shipment and delivery f.o.b. is 6 per cent.

The machine Fig. 3059, will drill holes up to 3/8 inch diameter, and is suitable for light work up to 6 inches diameter; it weighs 21 lbs. and stands 15 inches high, with a fly wheel 12 inches diameter. The frame is of malleable iron, and the spindle of steel, the geared wheels being made in gun metal.

Price complete with 6 drills	£2 5s.
Circular vice to suit	12s. 6d.
Self centring vice	£1 9s.

Packing for shipment and delivery f.o b. costs 6 per cent.

A machine similar in design but of larger proportions (not illustrated) is fitted with an improved form of hand wheel feed having steel screw working in a long gun metal bush against hardened steel centre for reducing friction and wear to a minimum; these machines can also be fitted with fast and loose pulleys for steam power or if desired, cone pulleys are provided instead of fast and loose ones, or lever feed motion instead of this wheel feed, at same prices.

PRICES OF BENCH DRILLING MACHINES.

To drill up to diameter of	$\frac{3}{4}$ in.	1 in.	$1\frac{1}{2}$ in.
" " a depth of	$2\frac{1}{2}$ in.	$3\frac{1}{2}$ in.	5 in.
To admit beneath drill	9 in.	11 in.	14 in.
" between table and drill	$3\frac{1}{2}$ in.	$4\frac{1}{2}$ in.	6 in.
Height of machine	25 in.	32 in.	35 in.
Price complete for hand power	£3	£5	£7 10s.
" " steam and hand power	£3 15s.	£6	£8 10s.
" of overhead motion	£3 15s.	£4 5s.	£4 15s.
Weight of machine complete	$\frac{3}{4}$	$1\frac{1}{2}$	$1\frac{3}{4}$

Packing for shipment and delivery f.o.b. is 6 per cent.

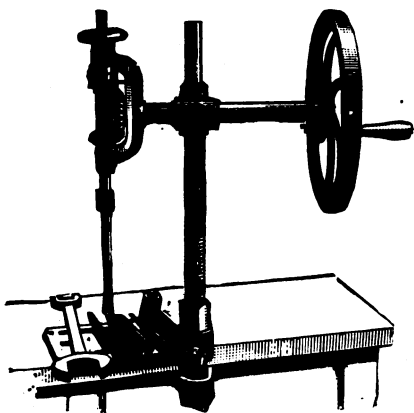

Fig. 3060.

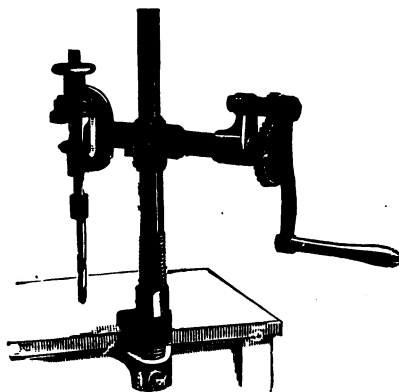

Fig. 3061.

PORTABLE HAND POWER DRILLING MACHINES of the type Figs. 3060 and 3061 are intended, to a large extent, to supersede the ratchet brace for drilling holes in work which cannot conveniently be brought to a machine driven by power.

This being the object in view the working parts are carefully finished, the steel drill spindle is provided with long bearings, and a roller bearing is introduced between the feed nut and the bracket. These improvements reduce friction and wear to a minimum, and it is claimed that they effect a saving of quite 60 per cent in the power required to work the machine as compared with drills of the ordinary construction. The feed motion is differential and automatic and a hand feed is provided which is found to be very useful for many purposes. All the geared wheels are made of malleable iron, and the set screw is fitted with dies which prevent the parts gripped being damaged.

PRICES OF DRILLING MACHINES, FIGS. 3060 and 3061.

Machine, Fig. No.	3060	3061
Diameter of spindle	$\frac{3}{4}$ in.	1 in.
Depth of hole drilled	5 in.	6 in.
Largest	$1\frac{1}{2}$ in.	$1\frac{3}{4}$ in.
Price of machine with 6 drills and spanner	£5 10	£6 15
Extra for twist drills	22/6	30/-
" " fly wheel	15/-	17/6
" " pulleys for driving by belt	15/-	17/6
" " tables	17/6	22/6

The cost of packing for shipment and delivery f.o.b. is 6 per cent.

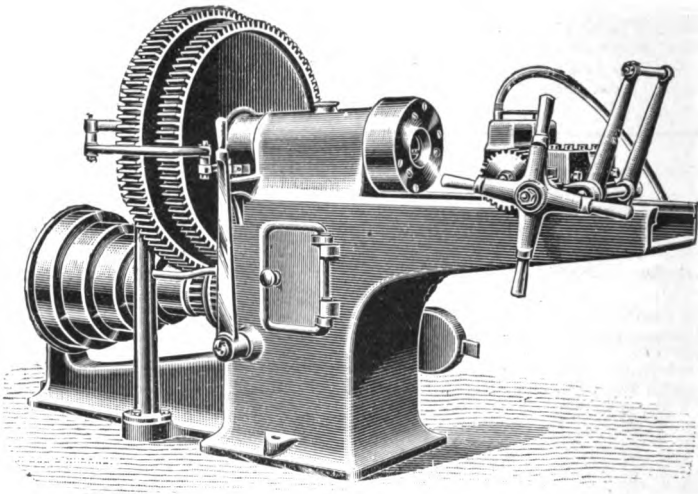

Fig. 3062A.

THE STANDARD SCREWING MACHINE, Fig. 3062A, will screw bolts or pipes of any length, or will tap nuts with once running up, and is provided with an automatic motion which releases the bolt at any desired point. This ensures uniformity in the length of thread and admits of the bolt being taken out, and replaced by a new one without stopping the machine.

The dies always run in one direction and are adjustable for wear; a self-acting oil pump provides complete lubrication, and washes the cuttings out of the die box as they are made.

The machine is provided with all appliances for producing accurate work, and is complete with dies, one tap for each size, tap holder, nut holder, overhead motions, belt guide, screw keys, &c.

PRICES OF SCREWING MACHINES, Fig. 3062A.

To screw Whitworth standard thread bolts and nuts of $\frac{1}{2}$, $\frac{3}{8}$, $\frac{1}{2}$, $\frac{5}{8}$, $\frac{3}{4}$, $\frac{7}{8}$, 1 , $1\frac{1}{8}$, $1\frac{1}{4}$, $1\frac{3}{8}$ and $1\frac{1}{2}$ inch diameter	£70
If with taps and dies for pipe $\frac{3}{8}$, $\frac{1}{2}$, $\frac{3}{4}$ and 1 inch diameter, extra	£7
„ „ master taps for re-cutting dies, extra	£5
To screw and tap bolts $\frac{1}{2}$, $\frac{3}{8}$, $\frac{1}{2}$, $\frac{5}{8}$, 1 , $1\frac{1}{8}$, $1\frac{1}{4}$, $1\frac{3}{8}$ and $1\frac{1}{2}$ inch diameter	£88
If with taps and dies for pipes $\frac{1}{2}$, $\frac{3}{4}$, 1 , $1\frac{1}{4}$ and $1\frac{1}{2}$ inch diameter, extra	£9
„ „ master taps for re-cutting dies	£7
To screw and tap bolts $\frac{3}{4}$, $\frac{1}{2}$, 1 , $1\frac{1}{8}$, $1\frac{1}{4}$, $1\frac{3}{8}$, $1\frac{1}{2}$, $1\frac{3}{4}$ and 2 inches diameter	£115
If with taps and dies for pipes $\frac{3}{4}$, 1 , $1\frac{1}{4}$, $1\frac{1}{2}$, $1\frac{3}{4}$, and 2 inches diameter, extra	£13 10s.
„ „ master taps for re-cutting dies, extra	£9

The cost of packing for shipment and delivery f.o.b. is 5 per cent.

SCREWING MACHINES.—Fig. 3062 represents a double geared machine (Brown's system), so largely and successfully used by Engineers, Ship Builders, Bolt and Tube makers, &c. This machine cuts the full thread, accurately and rapidly, on a bolt 2 inches diameter by one passage through the dies.

The bolt, pipe, or other work to be screwed, is held by a pair of strong jaws mounted on a carriage which slides on the bed, and has a quick hand traverse for withdrawing the work from the dies.

The (three) dies are adjustable to compensate for wear, and are carried in a revolving die box on the front end of the hollow revolving spindle. They are held in position and accurately adjusted by a hand lever, and an automatic motion releases the dies when any desired length of thread has been made, when another bolt may be screwed without stopping or reversing the machine.

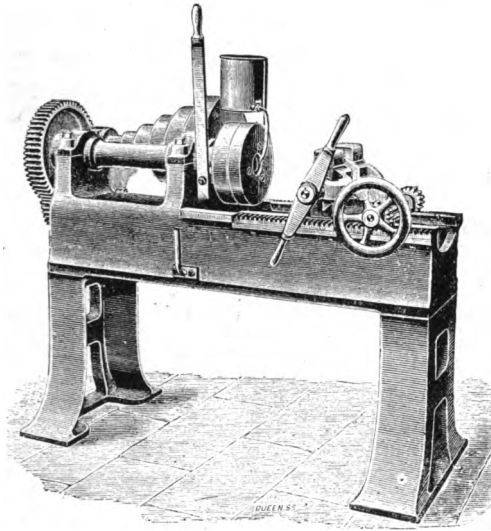

Fig. 3062.

For tapping nuts, the shank of the tap is gripped by holders in the revolving die box, the nuts being held by the jaws in the sliding carriage above described, and the nut is removed without stopping the machine.

The bed forms a trough for catching the lubricant used, and each machine is complete with overhead motion, drip can, screw keys, &c.

PRICES OF SCREWING MACHINES, Fig. 3062.

SINGLE SPEED MACHINE for screwing Whitworth standard threads, $\frac{1}{16}$, $\frac{1}{8}$, $\frac{3}{16}$, $\frac{1}{4}$, $\frac{5}{16}$, $\frac{3}{8}$, $\frac{1}{2}$ and 1 inch diameter		£49	0	0
Nine machine taps, with sockets for tapping nuts of each of above sizes		£3	15	0
Nine <i>each</i> master taps, parallel rhymers and guide plates, and one conical rhymmer for re-cutting the dies		£7	10	0
Extra dies, per set		£0	10	0
Approximate weight		11 cwt.		
DOUBLE GEARED MACHINE for screwing Whitworth standard threads, $\frac{1}{16}$, $\frac{1}{8}$, $\frac{3}{16}$, $\frac{1}{4}$, $1\frac{1}{8}$, $1\frac{1}{4}$, $1\frac{3}{8}$ and $1\frac{1}{2}$ inch diameter		£60	0	0
Nine machine taps, with sockets for tapping nuts of each of above sizes		£5	15	0
Nine <i>each</i> master taps, parallel rhymers and guide plates, and one conical rhymmer for re-cutting the dies		£10	0	0
Extra dies, per set		£0	12	6
Approximate weight		17 cwt.		
DOUBLE GEARED MACHINE for screwing Whitworth standard threads, $\frac{1}{16}$, $\frac{1}{8}$, $\frac{3}{16}$, $\frac{1}{4}$, $1\frac{1}{8}$, $1\frac{1}{4}$, $1\frac{3}{8}$, $1\frac{1}{2}$, $1\frac{3}{4}$ and 2 inch diameter		£68	0	0
Twelve machine taps, with sockets for tapping nuts of each of above sizes		£11	10	0
Twelve <i>each</i> master taps, parallel rhymers and guide plates, and two conical rhymers for re-cutting the dies		£18	10	0
Extra dies, per set		£0	12	6
Approximate weight		27 cwt.		
MACHINE FOR GAS THREAD DIES , $\frac{1}{2}$, 1, $1\frac{1}{4}$, $1\frac{1}{2}$ and 2 inch diameter		£65	0	0
Five machine taps for ditto		£4	10	0
Five <i>each</i> master taps, rhymers and guide plates, and one conical rhymmer for re-cutting dies		£9	15	0
Extra dies, per set		£0	12	6
Approximate weight		25 cwt.		

The cost of packing for shipment and and delivery f.o.b. is 5 per cent
 For hand power screwing machines, stocks and dies, &c., see pages 97, 98, 120, 122.

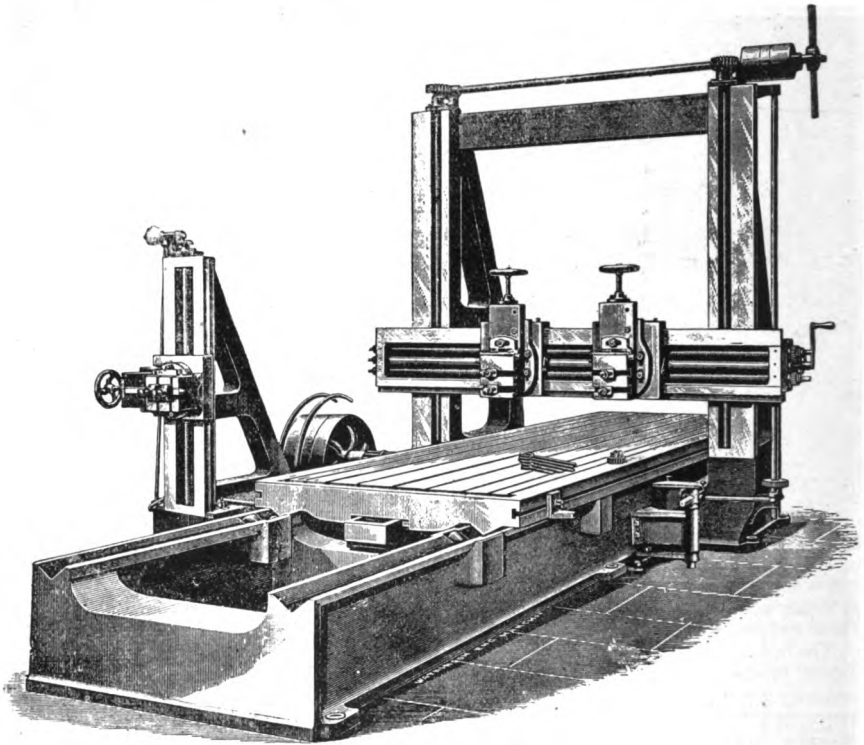

Fig. 3063

PLANING MACHINES.—The engraving Fig. 3063 represents a type largely used for heavy work, and consists of a massive bed with box section standards, which carry the cross slide and one or more tool boxes.

The table has ample sliding surfaces and is worked by rack and pinion with quick return motion and self-acting lubrication.

The cross-slide is raised or lowered by hand or power; the tool boxes work independently of each other and are self-acting in the vertical, horizontal and angular cuts.

A side-standard with its own self-acting tool box, on one or both sides of the table, is often extremely useful for planing pieces too large to pass between the side standards, and the extra cost of these will be found below.

Each machine is provided with all appliances for automatically regulating the traverse of the table, and is complete with screw keys.

PRICES OF PLANING MACHINES, Fig 3063.

To plane in length	12ft.	12ft.	12ft.
" " width	5ft.	5ft. 6in.	6ft.
" " height	5ft.	5ft. 6in.	6ft.
Price with one tool box	£370	£390	£410
Extra length of bed, per foot	£11 10 0	£12 10 0	£14
Approximate weight tons	15	16	17

PRICES OF ACCESSORIES FOR PLANING MACHINES.

Extra tool box for cross slide	£17	£17 10 0	£18
Side standard with self-acting tool box.. .. .	£36	£36 10 0	£37
Extra tool box for ditto	£23	£23 10 0	£24

The cost of packing for shipment and delivery f.o.b. is 5 per cent.

PLANING MACHINES for lighter work are similar to Fig. 3063 in general design, but the speeds, strength of parts, &c., are modified to suit the lighter work for which these machines are required.

The tables have quick return motion and are driven by rack and pinion or by screw, as desired, and each machine is complete with screw keys, &c.

PRICES OF PLANING MACHINES.

To plane in length	6ft.	8ft.	8ft.	10ft.	12ft.
„ „ width	2ft. 6in.	3ft.	3ft. 6in.	4ft.	4ft. 6in.
„ „ height	2ft. 6in.	3ft.	3ft. 6in.	4ft.	4ft. 6in.
Price with one tool box ...	£95	£120	£129	£185	£205
Extra length of bed per foot..	£6	£6 10 0	£7	£9 10 0	£10 10 0
Approximate weight ... tons	3	4½	5	8	9

PRICES OF ACCESSORIES FOR PLANING MACHINES.

Extra tool box for cross slide	£8	£9 10 0	£11 10 0	£13	£14
Side standard with self-acting tool box	£30 10 0	£32 0 0	£33	£35
Extra tool box for ditto	£15 10 0	£16 10 0	£18 10 0	£20
„ if driven by screw	£6 10 0	£7 10 0	£8 10 0	£10 10 0	£12 10 0

The cost of packing for shipment and delivery f.o.b. is 5 per cent.

SMALL PLANING MACHINES are built on the same lines as those above referred to, but have the quick motions adapted for the light work which they turn out much more accurately, and at less cost than it can be done by hand labour.

PRICES OF SMALL PLANING MACHINES.

To plane in length	3ft.	4ft.
„ „ width	1ft. 8in.	2ft.
„ „ height	1ft. 8in.	2ft.
Price with one tool box	£50	£66
Extra length of bed per foot	£3 15 0	£4
„ if driven by screw	£3	£3 10 0
Approximate weight tons	1½	2

The cost of packing for shipment and delivery f.o.b. is 5 per cent.

LOCOMOTIVE FRAME PLATE PLANING MACHINE.—These machines have been specially designed for planing the frame plates of locomotives, and the following is a brief description; the work is clamped to a fixed table and the tool is caused to travel. The machine consists of a travelling head carrying two independent tool boxes, each of which has two tool holders so arranged that two of them cut in one direction and, when the machine is reversed, the other two come into action; the travelling head is moved by two large screws, supported in a long continuous trough the whole length of the bed, and each end of the screw is fitted with adjustable thrust bearings for taking up wear.

Self-acting feed motions to the head in the horizontal, vertical and angular cuts are provided, and the machine is mounted on a strong bed; each machine is complete with fast and loose pulleys with self-acting reversing motions, strap guides and screw keys.

PRICES OF LOCOMOTIVE FRAME PLANING MACHINES.

To plane in length	24ft.	30ft.	36ft.
„ „ breadth	4ft. 6in.	4ft. 6in.	4ft. 6in.
Price	£555	£635	£745
Approximate weight tons	...	22	28	33

The cost of packing for shipment and delivery f.o.b. is 5 per cent.

PLATE EDGE PLANING MACHINES, Fig. 3064.—These machines are specially designed for rapidly and economically planing the edges of ship, boiler and other plates; also to bevel the edges of boiler plates ready for caulking. The machine is arranged with an overhanging clamp beam to admit and plane plates of any length. The bed is of massive and rigid construction, provided with a saddle having self-acting reversing motion. The traverse is effected by a steel screw of large diameter, supported in a long continuous trough, and each end of the screw is fitted with thrust bearings which are capable of adjustment for taking up wear. The tool box has a vertical traverse of 9 inches which may be self-acting if desired, and which, in any case, is arranged to turn over and cut in both directions. The cramp screws are of steel with wrought iron nuts. Each machine is complete with fast and loose driving pulleys, screw keys, &c.

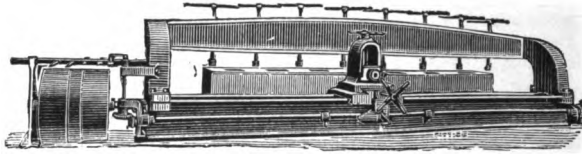

Fig. 3064.

PRICES OF PLATE EDGE PLANING MACHINES, Fig. 3064.

To plane in length without shifting plates	10ft.	12ft.	14ft.	16ft.	20ft.	25ft.	30ft.
Price	£150	£210	£225	£240	£286	£335	£385
Extra if driven by pair of steam engines	£75	£85	£85	£85	£100	£100	£100
Approximate weight tons	6	8	9	10	12	14	16

If fitted with bevelling arrangement, £5 extra any size.

„ „ self-acting vertical feed, £10 „ „

The cost of packing for shipment and delivery f.o.b. is 5 per cent.

SIDE PLANING MACHINES are made to suit almost any kind of work ranging from the smallest size to 30 feet long and 3 feet wide, or more, and by reason of the planing tool traversing over the work which is fixed to the saddles—adjustable in height—they occupy far less floor space than the Plate Edge Planing Machine, of the type Fig. 3064.

By removing the tables and providing a pit in front of standards, pieces of almost any size can be machined; as the arm carrying the tool box is the only part which traverses, the weight is always uniform and the speed of cut is the same whether large or small work is being planed. The length of stroke is regulated by adjustable tappets; it can be altered when desired, without stopping, and all machines have quick return motions.

It need scarcely be pointed out that, by turning the work, double the widths mentioned below will be machined.

The small machines are adapted for turning out work, varying widely in size and shape, with great economy in time and in the cost of production, when compared with that performed by most machines, or by hand labour.

The subjoined prices refer to only one length of bed, but machines with longer beds are made at a (relatively) small addition in the cost, and many modifications have been designed to fulfil special conditions.

PRICES OF SIDE PLANING MACHINES.

To plane in length	4ft.	5ft.	6ft.	10ft.	15ft.
„ „ width	1ft.	1ft. 3in.	1ft. 8in.	2ft. 6in.	3ft. 4in.
„ „ height	1ft.	1ft. 3in.	1ft. 8in.	2ft. 6in.	3ft. 4in.
Price	£88	£115	£135	£235	£410
Approximate weight... .. tons	1	1½	2½	5½	10

The cost of packing for shipment and delivery f.o.b. is 5 per cent.

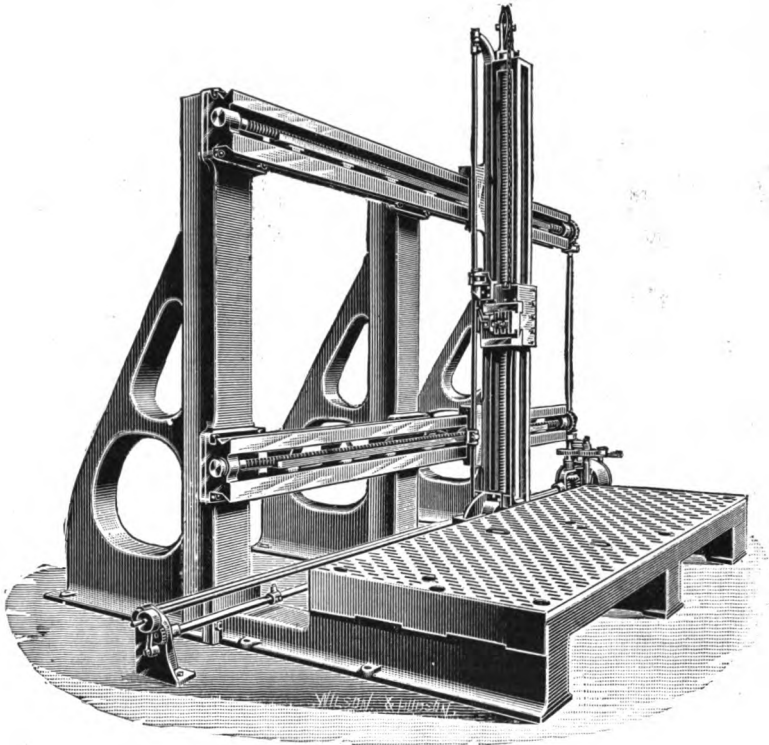

Fig. 3065.

WALL PLANING MACHINES, Fig. 3065.—The small floor space occupied by these machines and the wide range they command, vertically and horizontally, render them especially valuable in Marine Engine, Ship Building and other works, for machining work which cannot be dealt with on any machine of the ordinary type.

The standards, to which the cross slides are attached are supported in a vertical position, by strong brackets of box section, as shown, the lower end being secured to a heavy base plate with planed surface and T slots. In some cases however, the standards are attached to a wall or other similar support.

The tool box is counterweighted and slides by self-acting gear on a vertical beam, which is carried on the above named two cross slides, each of which is provided with screw gear to give the beam a self-acting traverse and quick return motion, in both directions. The cutting tool is adjustable to any angle and is self-acting in the horizontal, vertical or angular cuts.

The subjoined prices include the driving gear, fast and loose pulley, strap guide, &c.

If the machine is to be driven by its own engines, these will be supplied, with case hardened link reversing motion, at an extra cost of £110 Os. od. for any of the machines.

PRICES OF WALL PLANING MACHINES, Fig. 3065.

To plane in length	16ft.	18ft.	20ft.
„ „ height	10ft.	12ft.	15ft.
Price	£800	£900	£1050
Extra length of bed per foot	£18	£19	£20
Approximate weight tons	35	40	45

The cost of packing for shipment and delivery f.o.b. is 5 per cent.

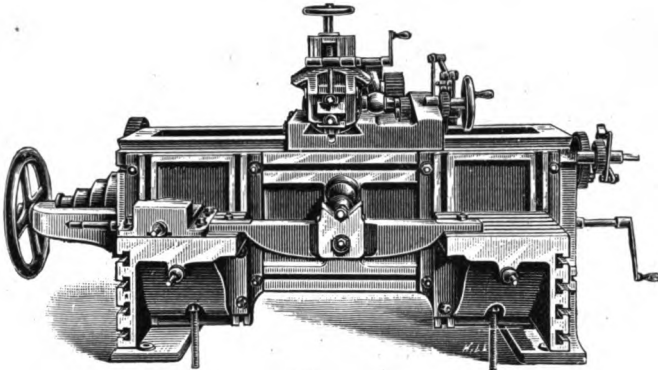

Fig. 3066.

SHAPING MACHINES, Fig. 3066, represents a powerful machine which has a stroke of 20 inches, one traversing head and two tables, but any of these machines will be provided with two traversing heads, each of which has self-acting motions as described below, these work independently of each other so that the heads can be adjusted for different lengths of stroke and be used for the same, or for two pieces of work as may be desired.

The bed is a massive casting of box section and has V slides on the top for carrying the arm or ram to which the tool box is attached, as shown, the front of the bed being provided with T slots to receive the traversing saddles to which the tables are attached.

The head, carried at the front end of the arm, has self-acting surfacing and quick hand traverse motions, the cutting and quick return motions being transmitted by means of a slotted link and strong double gear fixed at the back of the machine. The ram is indexed for adjusting the tool to the angle required, and the tool box can be provided with vertical slides for cutting downwards or planing angles; also a worm and quadrant, with machine cut teeth, for planing internal curves.

The traversing saddles which carry the tables are adjustable longitudinally by separate screws, and the height of each table is regulated by screw and bevil gear.

The tables have planed T slots on the top and side (for fixing work vertically), and one of them is frequently provided with a parallel vice for holding small objects.

An expanding conical mandril is provided, also a self-acting circular motion.

Each machine is sent out complete with overhead motions, serew keys &c., and the prices for different combinations will be found below; it may however be well to point out that, if two cutting heads are required the length of the bed should be increased sufficiently to give a useful traverse for each arm.

PRICES OF SHAPING MACHINES, FIG. 3066.

Stroke of arm	14in.	20in.	30in.
Length of bed	6ft.	10ft.	12ft.
Traverse of arm (with one head)	4ft. 1in.	7ft. 9in.	9ft. 6in.
Vertical feed of cutting tool	8in.	10in.	10in.
Tables to take in—depth	14in.	17in.	18in.
Size of horizontal table	20in. by 14½in.	21in. by 17in.	22in. by 18in.
„ vertical table	14½in. by 13in.	17in. by 15in.	17in. by 16in.
Price	£87	£128	£330
Extra if with two heads	£24	£65	£110
„ length of bed, per foot	£6	£8	£9
„ for parallel vice	£6	£7	£8
„ self-acting vertical feed	£1 10 0	£2 0 0	£5
Approximate weight as Fig. ... tons	2½	6	10

The cost of packing for shipment and delivery f.o.b. is 5 per cent.

SHAPING MACHINES for smaller work than those last referred to have motions and are in general arrangement essentially the same as those last described, but all these machines excepting only the smallest (6 in. stroke) are provided with the worm and quadrant gear, for machining internal curves.

PRICES OF SMALL SHAPING MACHINES.

Stroke of Machine	6in.	8in.	10in.	12in.
Length of Bed	3ft.	4ft.	4ft. 6in.	5ft.
Traverse of arm	1ft. 10in.	2ft. 8in.	3ft.	3ft. 3in.
Vertical feed of cutting tool	6in.	7in.	7in.	8in.
Table to take in—depth... ..	12in.	12in.	12in.	15in.
Size of horizontal table	14in. by 13in.	15in. by 14in.	16in. by 13in.	17in. by 14in.
„ vertical table	13in. by 12in.	14in. by 12in.	16in. by 13in.	14in. by 13in.
Price of machine	£40	£45	£54	£60
„ extra table		£5	£6	£7.
„ „ head		£15	£30	£38
„ „ bed per foot	£3	£3	£4	£5
„ self-acting down feed	£1 5 0	£1 10 0	£1 10 0
Approximate weight .. tons	$\frac{3}{4}$	1	1 $\frac{1}{2}$	1 $\frac{1}{2}$

The cost of packing for shipment and delivery f.o.b. is 5 per cent.

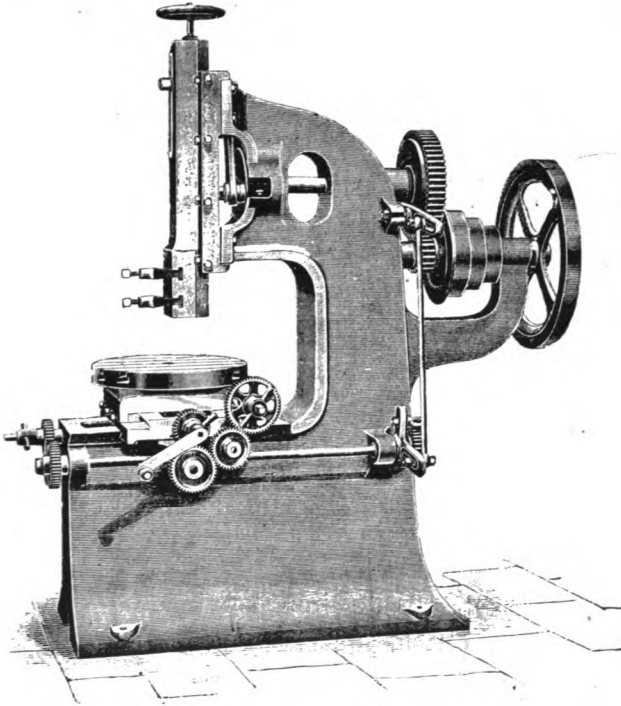

Fig. 3067.

SLOTING MACHINE, Fig. 3067, represents a tool which has a stroke of 7 inches, but machines, nearly identical in design, are made from 6 inches to 10 inches stroke. The arm works in long and carefully adjusted bearings, as shown, the stroke is adjustable and the disc plate is indexed for setting the stroke to the length desired.

The compound table is self-acting in the longitudinal transverse and circular cuts, the feeds are variable and can be worked independently of each other, or in any combination. The worm wheel which works the table is machine cut, and any of the machines can be provided with

motions to cant the table for cutting taper slots, key ways, &c., at the extra cost named below. Each machine is complete with overhead motions, one steel tool and a set of screw keys.

PRICES OF SLOTTING MACHINES, Fig. 3067.

Length of stroke inches	6in.	7in.	9in.	10in.
To admit on table diameter "	24in.	36in.	42in.	42in.
" " depth "	7in.	12in.	16in.	16in.
Longitudinal traverse of table "	14in.	14in.	17in.	17in.
Transverse " " "	8½in.	10in.	14in.	14in.
Diameter of table "	15½in.	20in.	24in.	24in.
Price of Machine	£37	£45	£65	£72
Canting motion for table, extra	£2	£3	£4	£5
Quick return stroke	£3	£3	£4	£5
Approximate weight tons	1	1½	2	2½

The cost of packing for shipment and delivery f.o.b. is 5 per cent.

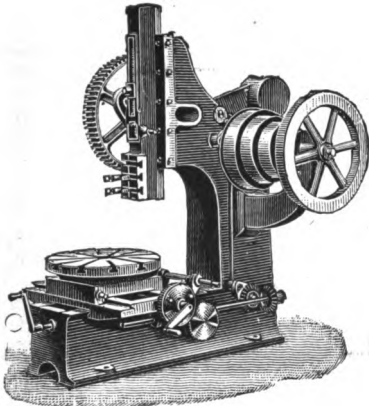

Fig. 3068.

DOUBLE-GEARED SLOTTING MACHINES.—Fig. 3068, illustrates a type of machine which is made in all sizes from 12 in. to 30 in. stroke. The different sizes necessarily vary somewhat in design, but there is no great deviation from that indicated in the engraving and, in all cases, the machine is of ample strength for the work to be done. The ram, or arm, works in long continuous guides and is counterweighted, the stroke is adjustable, and an index is provided for setting the stroke to any length within the capacity of the machine.

The table is compound and is self-acting in the longitudinal, transverse and circular cuts, any of which can be instantly disengaged, so that they may be worked in any combination. In addition to these advantages, the table has appliances for setting and fixing it at an angle for cutting taper key ways, &c., the arrangement of the driving gear admits of the machine being placed in line with other tools, and driven by an open instead of (as is requisite in many cases) a crossed strap, and all motions are

worked from one side, thus affording the operator convenient and complete control over the machine

The subjoined prices include overhead driving gear, one steel tool, screw keys, &c.

PRICES OF DOUBLE GEARED SLOTTING MACHINES, Fig. 3068.

Length of stroke... ..	12in.	14in.	16in.	20in.	24in.	30in.
To admit in diameter	3ft. 9in.	5ft.	6ft.	6ft.	7ft.	8ft.
" " depth	1ft. 4in.	1ft. 11in.	1ft. 11in.	2ft. 8in.	3ft.	3ft. 6in.
Longitudinal traverse of table	1ft. 9in.	2ft. 6in.	2ft. 6in.	3ft.	4ft. 6in.	6ft.
Transverse " "	1ft. 3in.	2ft.	2ft.	2ft. 6in.	3ft.	4ft. 9in.
Price of machine	£105	£155	£210	£255	£425	£670
Approximate weight tons	2½	4½	6	8½	15	22½

The cost of packing for shipment and delivery f.o.b. is 5 per cent.

PLATE STRAIGHTENING MACHINES, Fig. 3069, straighten, flatten, and take the "buckle" out of steel, iron or other rolled plates, with a great saving in cost, and leave a far better surface than can be obtained by hand straightening, which inevitably leaves marks plainly visible in all work, especially that which has to be painted, such as Gas-holders, Locomotive tenders, Tanks, &c.

The machine consists of a set of seven rollers, carried in side frames which are secured to a strong iron base plate. The four top rollers are not driven and revolve only when in contact with the plate to be made level. These rollers are carried in end bearings, and have a

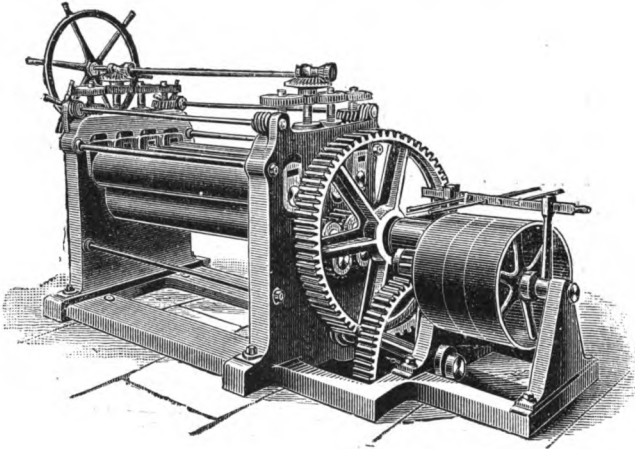

Fig. 3069.

simultaneous vertical adjustment by suitable gearing worked by square threaded screws and a hand wheel, the two outer rollers have an additional and independent adjustment for use when required.

The lower set of (three) rollers—the central roller being made of cast steel—are driven by steel pinions in connection with the main driving shaft, which is provided with fast and loose pulleys.

The machine is complete with strap guide, screw keys &c., or, if desired, the driving pulleys may be replaced by a steam engine with reversing gear, forming part of the machine.

PRICES OF PLATE STRAIGHTENING MACHINES, Fig. 3069..

Section of plates flattened	$\frac{1}{8}$ in.	$\frac{1}{4}$ in.	$\frac{3}{8}$ in.	$\frac{1}{2}$ in.
Width of " " " " " " " "	4ft. 6in.	5ft.	6ft.	6ft. 3in.
Price of machine with pulley	£145	£210	£275	£355
" " " " " " " " " " " " " "	£178	£250	£320	£410
Approximate weight tons	5	9	11	17

The cost of packing for shipment and delivery f.o.b. is 5 per cent.

PLATE BENDING ROLLS, Fig. 3070, represents a machine to take in plates up to 8 feet long, and roll any thickness up to $\frac{1}{2}$ inch or $\frac{3}{8}$ inch thick, which may be regarded as a usual section.

Machines for bending heavier sections are of, proportionately, more massive construction. the bottom rolls are supported by rollers carried in a strong pedestal bolted to the foundation plate, and the top roll is adjusted by worm and wheel gear, or by power, instead of by the screws shown in the engraving which is a convenient mode of adjustment for the smaller machines.

The side frames or " housings " are, in all cases, bolted to a continuous bed plate and rigidly connected above by wrought iron tie bolts. The frames are bored, in the position indicated in the engraving, to receive the two bottom rolls, the top one being carried on sliding blocks at each end adjustable by screw or worm gear.

For removing tubes after they have been rolled to the diameter required, one of the side frames is made in two parts to swivel clear of the top roll and so admit of the tube being withdrawn. The rolls are usually made of hard cast iron carried on a wrought iron or mild steel central shaft turned at the ends to form the journals. If desired the rolls may be made in wrought iron or steel at an extra cost proportionate with what is required.

The machines are complete with fast and loose pulleys, striking gear, lever and screw keys unless driven by separate engines, the cost of which will be found on next page.

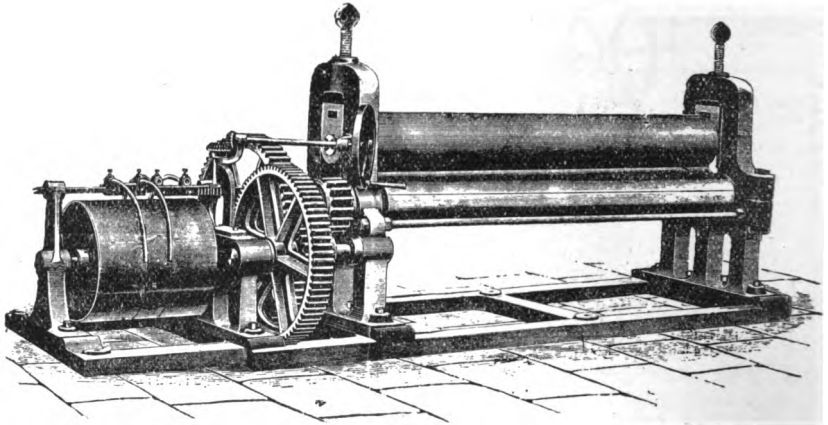

Fig. 3070

PRICES OF PLATE BENDING ROLLS, Fig. 3070.

To bend plates, wide ...	3ft.	4ft.	6ft.	8ft.	10ft.	12ft.	12ft.	16ft.
„ „ thickness ...	3in.	3in.	7 ¹ / ₈ in.	4in.	5in.	6in.	8in.	11 ¹ / ₂ in.
Diameter of top rollers ...	5in.	6in.	9in.	12in.	14in.	16in.	18in.	22in.
„ „ bottom rollers ...	5in.	6in.	8in.	9in.	12in.	13in.	15in.	18in.
Price	£47	£65	£90	£130	£220	£300	£450	£720
Approximate weight ... tons	1 ¹ / ₂	2	4	6	10	12	18	28
Price with steam engine	£135	£148	£258	£362	£520	£820
Approx. weight do. tons	4 ¹ / ₂	6 ¹ / ₂	11	13	19 ¹ / ₂	30

The cost of packing for shipment and delivery f.o.b. costs 5 per cent.

ANGLE, T AND BAR BENDING MACHINE for bending to a complete circle angle or T sections up to 4¹/₂ inches, square bars up to 3 inches or flat bars of equivalent sections.

The machine consists of a strong cast iron frame with a planed table fitted with three V shaped slides, each carrying a roller. These rollers are worked simultaneously by steel worm gear, and are adjusted by a square threaded screw and cross handle, and are easily changed for others of a different section. Four adjustable bearing rollers, which form rests to support the work being manipulated, are carried in swivel brackets secured to the sides of the frame.

The wrought iron parts are carefully case hardened, where necessary, and each machine is complete with a set of rollers 16 inches diameter for bending flat bars, fast and loose pulleys for cross and open belts, all gearing, belt forks, screw keys, &c.

The price of the machine is £125.

The approximate weight is 4¹/₂ tons.

The cost of packing for shipment and delivery f.o.b. is 5 per cent.

DOUBLE GEARED PUNCHING AND SHEARING MACHINES, Fig. 3071, are constructed with massive frames, steel shafts, heavy gear, and steel pinions to withstand the strains incidental to punching and shearing large sections and, to provide for difficulties in transit (or other conditions) the frames can be made in two parts with heavy faced flanges (as shown in the engraving) and connected by turned bolts. The extra cost of this is about 5 per cent which, in many cases is a very small item compared with the extra transit charges for heavy pieces.

The punching and shearing tools are at opposite ends, the shears for cutting angle or other bars being central, and an improved disengaging motion instantly stops either the punch or the angle iron shears.

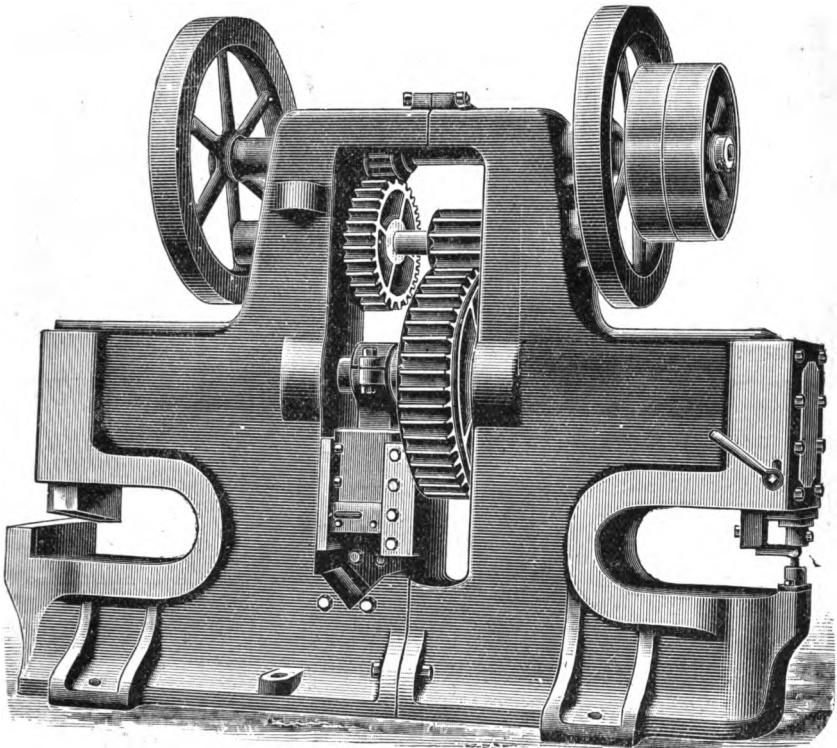

Fig. 3071.

In all cases the diameter of hole indicates the thickness of plate the machine will punch or shear, and the subjoined prices include a pair of best cast steel shear blades, punch and die, and a recessed die holder which admits of the tools being changed without removing the holder.

In many cases such a machine is required for work which is at a distance from a line of shaft or a motor and, to meet such cases, engines are provided, so that it is entirely self-contained and may be used in any position irrespective of other driving power. The cost of this addition as well as that of swing cranes at each end of the machine, which are very useful when manipulating heavy plates, will be found below.

PRICES OF DOUBLE GEARED PUNCHING AND SHEARING MACHINES, Fig. 3071.

To punch holes—diameter ...	5in.	1in.	1½in.	1in.
To shear plates—thickness ...	¾in.	1in.	1½in.	1in.
To punch from edge of plate ...	20in.	19in.	18in.	30in.
To shear " " " ...	20in.	19in.	18in.	30in.
To shear angle bars ...	3½in. by 3½in.	4in. by 4in.	6in. by 6in.	6in. by 6in.
Price, to punch and shear only...	£100	£135	£190	£196
" " and with angle iron shears ...	£116	£254	£210	£218
Extra if with steam engine ...	£25	£25	£25	£30
" " 2 jib cranes ...	£25	£28	£35	£38
" " shears at an angle to shear bars of any length }	£7	£8	£10	£10
Approx. weight with shears but without engine ...	4½	6½	8½	9½

PRICES OF DOUBLE GEARED PUNCHING AND SHEARING MACHINES,
Fig. 3071—Continued.

To punch holes—diameter ...	1½in.	1½in.	1½in.	2in.
To shear plates—thickness ...	1½in.	1½in.	1½in.	2in.
To punch from edge of plate ...	22in.	30in.	33in.	30in.
To shear " " ...	22in.	24in.	30in.	30in.
To shear angle bars " ...	6in. by 6in.	6in. by 6in.	8in. by 8in.	10in. by 10in.
Price, to punch and shear only ...	£288	£410	£585	£840
" " and with angle iron shears ...	£310	£440	£620	£880
Extra if with steam engine ...	£30	£55	£55	£60
" " 2 jib cranes ...	£45	£45	£45	£50
" " shears at an angle to shear bars of any length	£11	£15	£15	£20
Approx. weight with shears but without engine ...	15	21	26½	38

The cost of packing for shipment and delivery f.o.b. is 5 per cent.

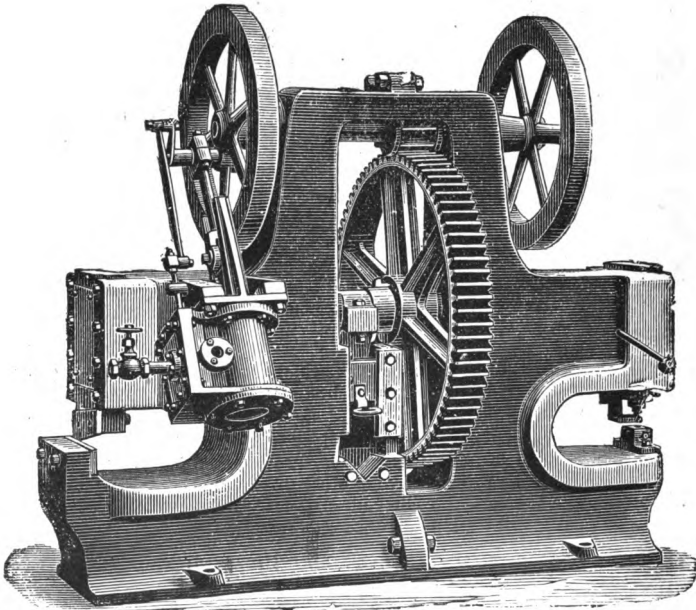

Fig. 3072.

The machine Fig. 3072 is single geared, and is provided with its own steam engine and two fly wheels, as shown, but the same machine is made, with fast and loose pulleys for driving by belt, in lieu of the engine.

The double geared machines of both types are similar in construction to Fig. 3071, and the proportions are increased to the extent required for the heavier sections to be worked.

The price of the machine to punch holes ¾ inch diameter, and to shear plates ¾ inch thick at 20 inch from the edge is ...	£98	0	0
If with angle iron shears, extra ...	£12	0	0
" " engine, extra ...	£22	0	0
" " shears at an angle to shear bars at any length, extra ...	£6	0	0

The cost of packing for shipment and delivery f.o.b. is 5 per cent.

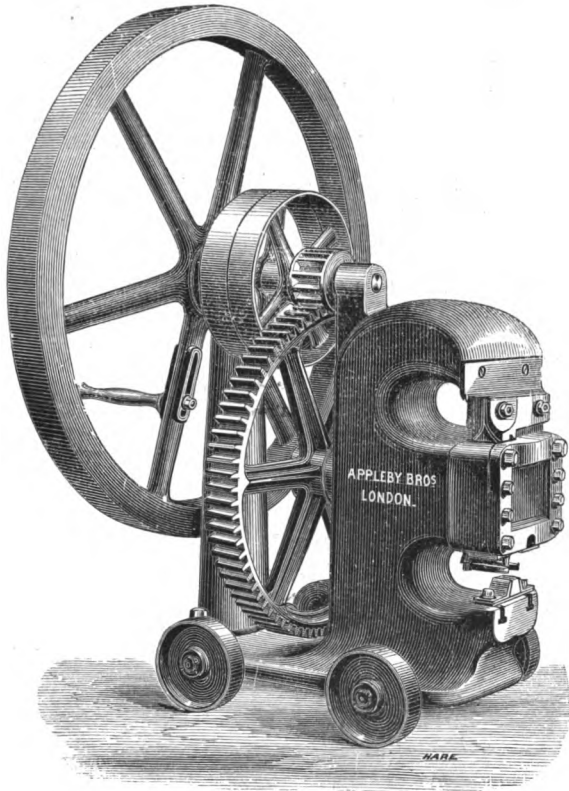

Fig. 3073.

THE PUNCHING AND SHEARING MACHINE, Fig. 3073, is arranged to punch and shear on the same side, the shear being above the punch and at an angle, for cutting long bars. The slide which gives motion to the punch and to the shear blade, is worked by a steel eccentric shaft and suitable gear. The fast and loose pulleys on the pinion shaft are carried between two bearings, which is a distinct advantage over many machines which have no outer bearing.

The punch is fitted with a stop motion, and each machine is provided with one best steel punch and die, one pair of shear blades and a recessed die holder, so that different sizes of dies may be fixed without removing the die-holder.

If the machine is required to work by hand power it should have an extra large fly wheel, and the price for this and for mounting the machine on four wheels, as shown, will be found below.

PRICES OF PUNCHING AND SHEARING MACHINE, FIG. 3073.

To punch holes—diameter	3in.	4in.	5in.	6in.
To shear plates—thickness	3in.	4in.	5in.	6in.
To punch or shear from edge of plate	9in.	10in.	12in.	12in.
Price of Machine	£25 0 0	£31 0 0	£44 0 0	£55 0 0
Extra for large fly wheel for hand power	£2 0 0	£2 2 6	£2 5 0	£2 10 0
„ if mounted on four wheels	£1 15 0	£1 17 6	£2 0 0	£2 5 0
„ punches and dies per pair	£0 10 0	£0 12 6	£0 15 0	£0 16 0
„ Shear blades per pair	£1 5 0	£1 10 0	£1 12 6	£1 15 0
Approximate weight tons	½	1½	2	2½

The cost of packing for shipment and delivery f.o.b. is 5 per cent.

MACHINES FOR RIVETTING, FLANGING, FORGING, ETC.—Much useful work has been done by machines driven by steam, compressed air or by mechanism in (or without) combination with one or other of the above named modes of producing pressure. But the advantages derived from the use of Mr. Tweddell's system of working by direct hydraulic pressure are so conspicuous, that the other systems need not be referred to in detail.

HYDRAULIC MACHINE TOOLS (TWEDELL'S SYSTEM).—The salient advantages of this mode of distributing power are that:—

The pressure is conveyed in tubes of small diameter, in any direction and to almost any distance, without appreciable loss in useful effect.

The pressure is steady and continuous, and can be maintained as long as desired, or can be instantly shut off—as, for instance—for releasing work or tools which require re-adjustment.

Heavy tools worked by hydraulic pressure require far less foundations than those of similar power driven by belt, whilst the portable tools are so easily transported and manipulated, that they can be taken to the work, and thus save the time and expense incurred in bringing the work to the tools.

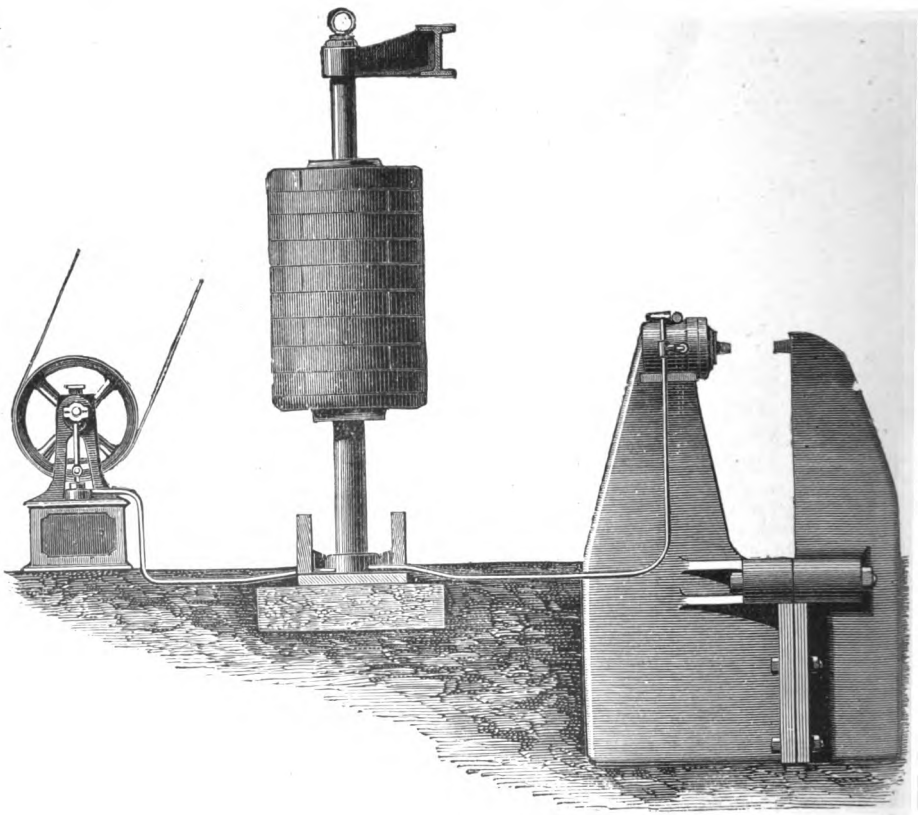

Fig 3074.

The arrangement of machinery indicated in Fig. 3074, must be regarded rather as an illustration of the system than as one to be adopted in practice and, although the machines, referred to in the following pages are in general use, modifications are so frequently required to adapt them for special work that the following illustrations, dimensions, prices &c., are intended, principally, as a basis for approximate estimates.

Designs for machines to fulfil special conditions are constantly being made, and the price of these, as well as for plant to fulfil any given conditions, will be prepared on receipt of accurate information, and details of the work contemplated.

PRESSURE PUMPS are invariably made (unless otherwise agreed) to work at a pressure of 1,500 lbs. per square inch.

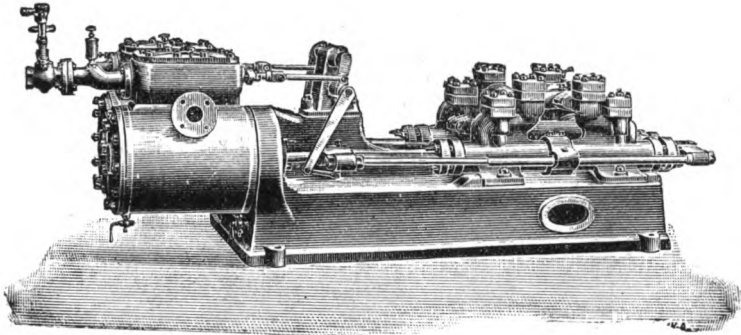

Fig. 3075.

DUPLEX STEAM PUMPS of the type Fig 3075, are now almost universally used to drive plants of even moderate size, because they enable the hydraulic tools to be worked quite independently of the shop engines or shafting, which is a great advantage when overtime is being worked.

The slide valves are worked by swinging levers, and receive motion from the cross-head of the opposite engine.

The pumps are of the four ram type, the glands are bushed with gun metal, and the pumps are fitted with screwed gun metal seats and gun metal valves.

PRICES OF DUPLEX PUMPS, Fig. 3075.

Diameter of cylinder ...	7in.	8in.	10in.	12in.	14in.	16in.	18in.	20in.	28in.
Length of stroke ...	12in.	12in.	12in.	12in.	12in.	12in.	12in.	12in.	24in.
Number of pumps ...	4	4	4	4	4	4	4	4	4
Diameter „ ...	1½in.	1¾in.	1¾in.	2in.	2½in.	2¾in.	3¼in.	3½in.	4½in.
Stroke „ ...	12in.	12in.	12in.	12in.	12in.	12in.	12in.	12in.	24in.
Steam pressure lbs.	70	58	70	66	70	70	70	70	70
Approx. delivery galls.	0½	8	14	19	30	37	50	60	120
Price of pump ...	£103	£118	£155	£188	£225	£265	£308	£350	£580

The cost of packing for shipment and delivery f.o.b. is 5 per cent.

VERTICAL PRESSURE PUMPS WITH ENGINES to supply hydraulic pressure at 1500 lbs. per square inch, are similar in general design to Fig. 3076 but are complete with engines and all driving appliances in lieu of the driving pulleys shown in the engraving on the following page.

PRICES OF VERTICAL THREE THROW PUMPS WITH ENGINES, Type Fig. 3076.

Diameter of ram ...	in.	1½	1¾	1¾	2	2½	2½	3	3½
Stroke of ram ...	in.	4	4	5	5	5	6	6	6
Price complete...	...	£250	£258	£277	£296	£309	£375	£398	£453

The cost of packing for shipment and delivery f.o.b. is 5 per cent.

PRICES OF VERTICAL TWO THROW PUMPS WITH ENGINES, Type Fig. 3076.

Diameter of ram ...	in.	1½	1¾	1¾	2	2½	2½	3	3½
Stroke of ram ...	in.	4	4	5	5	5	6	6	6
Price complete...	...	£200	£206	£221	£237	£247	£300	£318	£362

The cost of packing for shipment and delivery f.o.b. is 5 per cent.

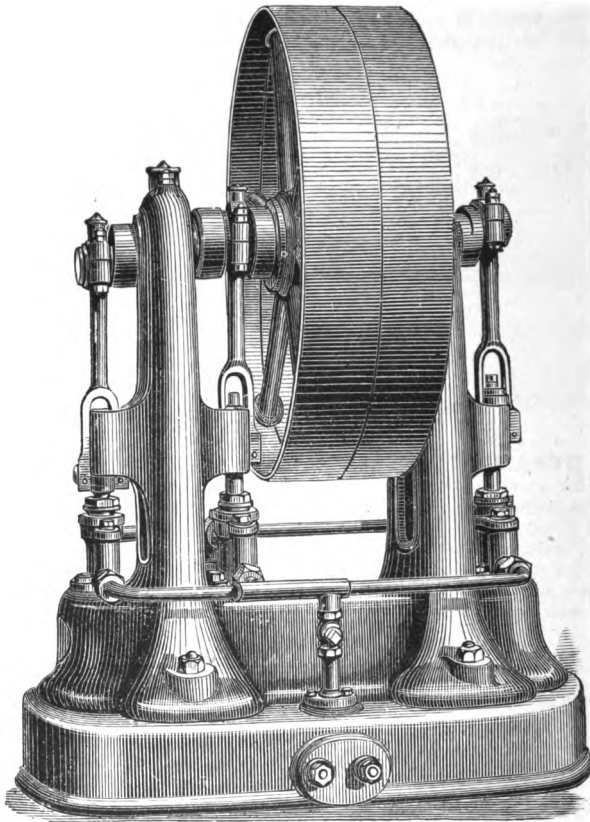

Fig. 3076.

BELT DRIVEN PRESSURE PUMPS of the type Fig. 3076 are made in sets of two and three rams, constructed to work at a pressure of 1,500 lbs. per square inch and are used for small installations of hydraulic machines, or where surplus power is available.

The maximum speed should not exceed 80 revolutions per minute and, to adapt the pumps to work continuously at these high speeds and pressures, the construction, materials and workmanship need to be exceptionally solid and good.

The crank shaft is of mild steel and is carried in long gun metal adjustable bearings, arranged to take the thrust from the rams, on solid metal and not (in the usual manner) by a bearing cap secured by bolts.

The pump barrels, glands, valves and seatings are made of the hardest gun metal, the connecting rods are of forged scrap iron, the lower end being forked to span the guide block, and the upper end fitted with heavy gun metal heads of the type used in marine engines.

The loose pulley is bushed with gun metal, the fast pulley is made heavy to act as a fly wheel, and all appliances are provided for stopping and starting the pumps, automatically, so that power is used only when it is required for actual work.

The base is a massive casting which serves as a tank for the pressure water, and the pumps are complete with all connections for suction and attachment with the pressure main.

PRICES OF VERTICAL BELT DRIVEN THREE THROW PUMPS, Fig. 3076.

Diameter of rams	... inch	1½	1¾	1¾	2	2½	2½	3	3½
Stroke	... "	4	4	5	5	5	6	6	6
Price complete	... "	£109	£117	£128	£140	£153	£203	£242	£265

The cost of packing for shipment and delivery f.o.b. is 5 per cent.

PRICES OF VERTICAL BELT DRIVEN TWO THROW PUMPS, as Fig. 3076.

Diameter of ram ... in	1½	1¾	1¾	2	2½	2½	3	3½
Stroke of ram ... in.	4	4	5	5	5	6	6	6
Price complete ...	£87	£94	£102	£112	£122	£162	£194	£212

The cost of packing for shipment and delivery f.o.b. is 5 per cent.

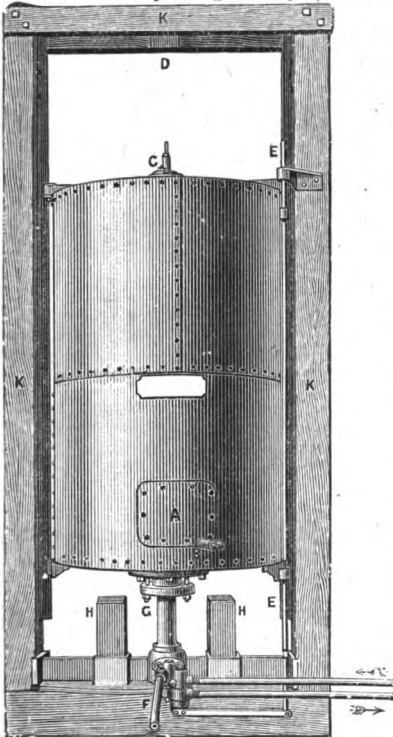

Fig. 3077.

ACCUMULATORS.—These are made in the two types indicated in Figs. 3074 and 3077 and, evidently, should in all cases, have a capacity in excess of that requisite for the supply of pressure to all the machines which can be at work at one time.

SELF CONTAINED ACCUMULATORS, as shown in the engraving Fig. 3074, consist of a ram and cylinder secured to a strong cast iron base, provided with connections for the pressure water from the pumps and from the accumulator to the machines.

The upper end of the ram is guided by a strong cast iron bracket which is attached to a cross beam or wall. The weights are cast iron segments, and the bottom ring, which is supplied with the machine, is included in the subjoined prices; the other segments to complete the weighting, are provided by the purchasers.

The Machine is complete with all necessary valves and connections for pressure pipes, and the prices for the several sizes are the same as those for Weight Case Accumulators.

WEIGHT CASE ACCUMULATORS.

—In the arrangement illustrated by Fig. 3077, the cast iron segments are replaced by a wrought iron casing which is filled, to the extent required, with scrap iron, slag, stone or other materials at hand, to give the required pressure of 1,500 lbs. per square inch.

The subjoined prices include the base plate, cylinder, ram and all necessary valves, but not the timber frame, this being constructed by the purchaser.

PRICES OF ACCUMULATORS, Fig. 3074 and 3077.

Diameter of ram ... in.	4	4½	5	6	7	8	10	14
Stroke of ram ... ft.	6	7	8	8	12	14	15	20
Price of accumulator ...	£68	£80	£92	£115	£159	£187	£280	£465

The cost of packing for shipment and delivery f.o.b. is 5 per cent.

AUXILIARY ACCUMULATORS.—In order to insure a constant pressure in all the machines comprised in a large installation, distributed over a considerable area, it may be found desirable to have one or more subsidiary accumulators, fixed in convenient positions, in the same manner as has been so successfully adopted in providing for the service of cranes and other machines in docks, goods warehouses, &c.

This is the more necessary where, for convenience of position, supervision or other motive, it may be desirable to have the main pumps and accumulator at a distance from some of the tools. In such cases the interest on the small outlay for these subsidiary accumulators, will be insignificant when compared with the absolute saving effected in the wages of a special driver, and the advantage arising from the pressure being always available for working the machines served by the accumulator.

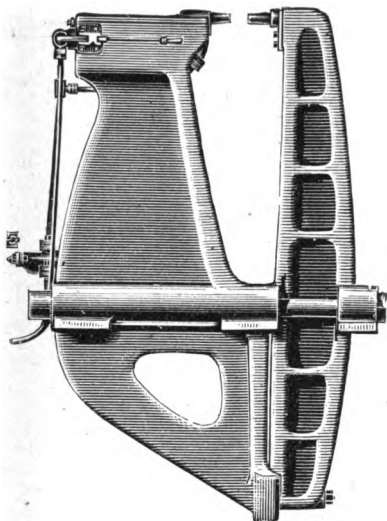

Fig. 3078.

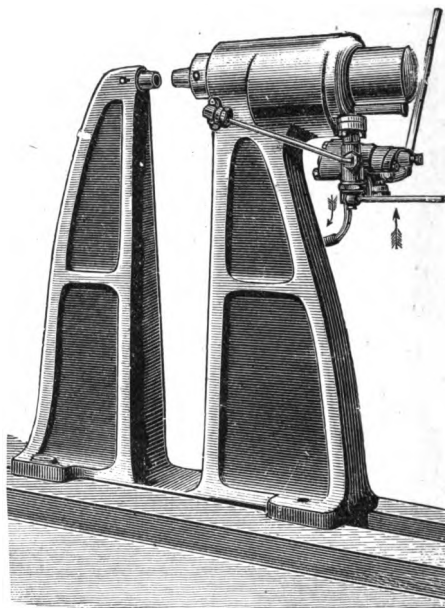

Fig. 3079.

FIXED HYDRAULIC RIVETTERS of the types Fig. 3078 and 3079, are used for Marine, Locomotive and Land Boiler work, and are made to close rivets from $\frac{1}{2}$ inch up to $1\frac{1}{8}$ inch diameter and take in plates from 3 feet to 12 feet wide.

The larger machines illustrated by Fig. 3078 have a separate hub connected to the main standard by steel bolts. The smaller machines (Fig. 3079) are made in one steel casting.

THE DOUBLE POWER referred to in the list of prices is extremely useful where one machine is required for a large range of work—from heavy to very light work—and the range is, sometimes, still further extended by adding a treble power.

The machines are sent out complete with the pressure cylinder, valves and levers for working it, as shown, and a stop valve for connection with the pressure main, the whole being equal to a working pressure of 1,500 lbs. per square inch.

For prices of pressure pumps and accumulators see the preceding pages.

The subjoined prices include the flush top but not the plate closing appliances which firmly hold the plates whilst the rivet is put in and closed. The extra cost of these varies from £28 to £75.

If the machines have the ordinary round tops, the cost is reduced by from £25 to £40, and if single power only is required there will be a reduction varying from £15 to £25.

APPROXIMATE PRICES OF FIXED HYDRAULIC RIVETTERS, Fig. 3078.

Depth of gap	feet	$7\frac{1}{2}$	8	$10\frac{1}{2}$	12	$7\frac{1}{2}$	8	$10\frac{1}{2}$	12
Maximum pressure	tons	100	100	100	100	150	150	150	150
Minimum	" "	40	40	40	40	60	60	60	60
Price of machine	" "	£585	£610	£695	£780	£835	£870	£1065	£1162

APPROXIMATE PRICES OF FIXED HYDRAULIC RIVETTERS, Fig. 3079.

Depth of gap	feet	4½	5	5	6	6	6
Maximum pressure	tons	30	30	50	30	50	70
Minimum	"	15	15	20	15	20	35
Price of machine	"	£230	£235	£300	£250	£350	£400

In both cases the cost of packing for shipment and delivery f.o.b. is 5 per cent.

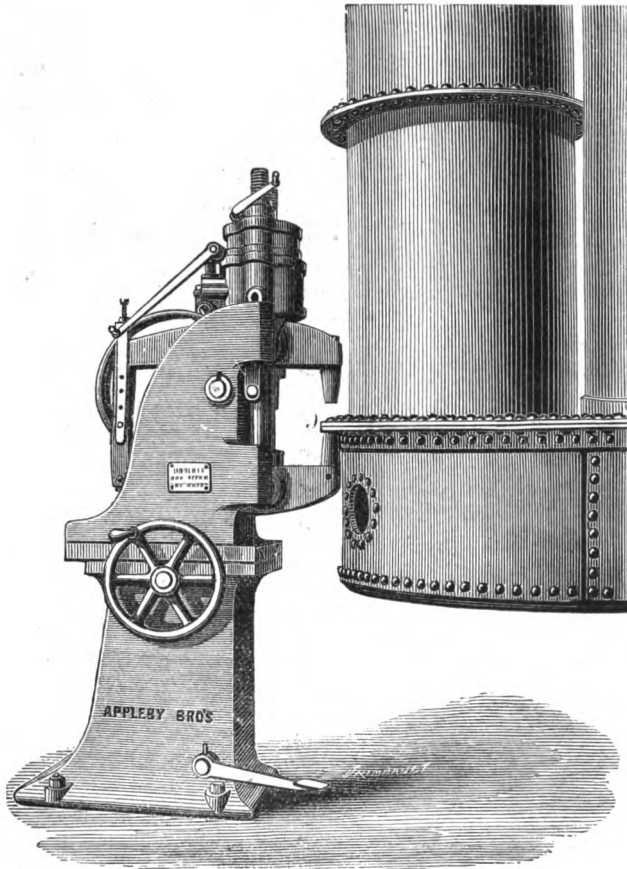

Fig. 3080.

FIXED RIVETTER WITH SLIDING BED, Fig. 3080.—Machines of this construction are usefully employed for rivetting external flanges, flues, &c. as shown in the engraving, but it was designed and used by the Author, more especially for closing three rows of rivets in Bridge girders, the object being to leave the overhead travelling crane (generally used for suspending the work) free for general work.

To accomplish this, the standard which carries the rivetting machine is made in two parts, both having faced surfaces. The upper part is moved backward or forward by worm and wheel gear, so that the girder being staked together and placed on two trollies, is easily propelled in front of the tool, and the three rows of rivets are finished without adjusting the position of the girder in a transverse direction. The machine will close rivets ½ inch diameter and the jaws can be made to take in work of almost any depth required.

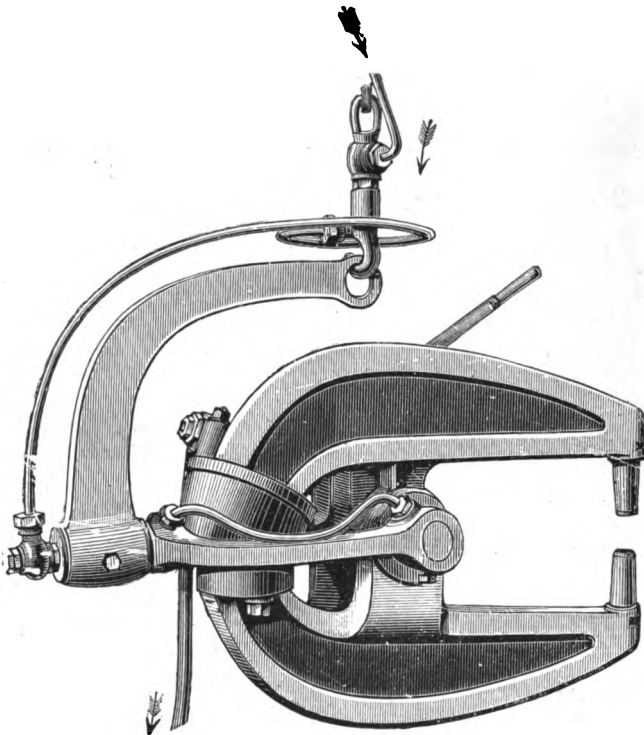

Fig. 3081.

PORTABLE HYDRAULIC RIVETTERS OF THE LEVER TYPE,

Fig. 3081.—The pressure cylinder for closing the jaw being removed from the cupping dies, these machines close rivets in positions which cannot be reached by a direct acting tool, the rigidity due to the last named construction is, however, maintained by the use of the patent curved cylinder.

The subjoined prices include Bow or Side Hangers.

PRICES OF PORTABLE LEVER RIVETTERS, Fig. 3081.

Depth of gap in.	15	18	24	30	36	42	48	54	60	66
Width „ „	12	12	12	15	15	15	15	15	15	15
Price of machine	£86	£99	£115	£123	£134	£138	£141	£145	£154	£165

If with Compound Hanger, as illustrated, *add* about 10 per cent.

If with eye bolts for attachment, *deduct* about 10 per cent.

The cost of packing for shipment and delivery f.o.b. is 5 per cent.

PRICES OF PORTABLE RIVETTERS, Fig. 3082.

Depth of gap in.	12	18	24	30	36	42	48	54	60	66
Width „ „	13	13	13	15	15	15	15	15	15	15
Price of machine	£82	£90	£104	£108	£118	£134	£138	£144	£150	£155

The cost of packing for shipment and delivery is f.o.b. 5 per cent.

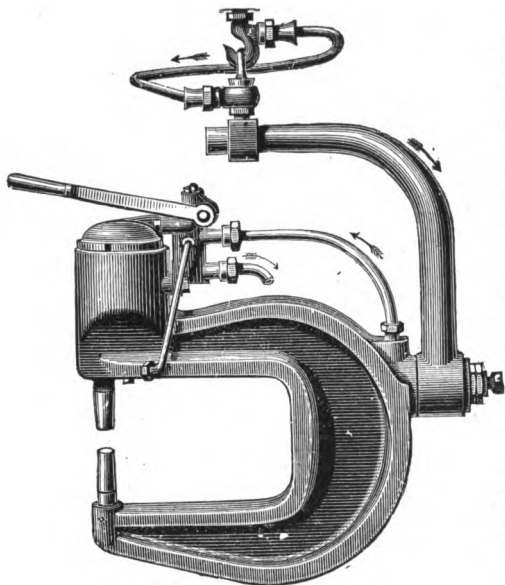

Fig. 3082.

PORTABLE DIRECT ACTING RIVETTERS, with bow hanger, as illustrated by Fig. 3082, are made with gaps ranging from 8 inches to 66 inches, and to close rivets from $\frac{1}{2}$ inch to $1\frac{1}{4}$ inch diameter but, unless otherwise specified, it may be assumed that they will be equal to closing iron rivets of any diameter up to 1 inch, or steel rivets up to $\frac{7}{8}$ inch.

The prices given above include the Bow Hanger, shown in the engraving, but in the simplest form, the machine is suspended from eye bolts attached to the frame; these tools are also made with a Compound Hanger similar to Fig. 3081, which gives great facility for adjusting the machine to work in any position, and the extra cost of this Hanger is about 10 per cent.

The eye bolts, above referred to answer quite well for many purposes, and the cost of rivetters with this attachment is about 10 per cent. less than for machines with the Bow Hanger shown in Fig. 3082.

These tools are used for a wider range of general work as well as for rivetting boilers, girders, ships frames, &c.

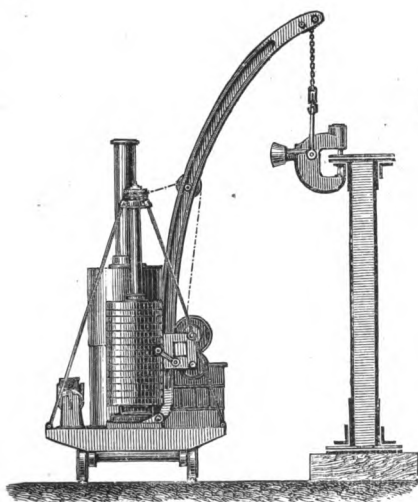

Fig. 3083.

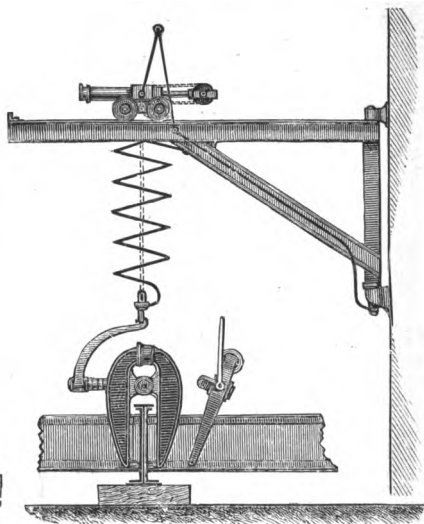

Fig. 3084.

TRAVELLING HYDRAULIC RIVETTING PLANT of the type indicated in Fig. 3083, has been used by the writer with most satisfactory results in regard to quality of work, and economy in time and in cost of labour. In this case (as in many others) it was convenient to have the pressure pumps, accumulator, rivet heating furnace and swing jib crane, mounted on a strong under-carriage with travelling wheels, so that the complete plant could be readily transported to the place where its services were required.

The pumps and accumulator have a capacity equal to supplying another rivetting machine which may be suspended from an ordinary jib or crane for use in other parts of the work, or for driving hydraulic punching or other machines.

The price of the plant complete, as above, exclusive of the rivetting machines, varies from £330 to £485.

The rivetter may be suspended from a jenny of the construction above indicated, or it may have hand power lifting and traversing gear, or such other arrangement as may be convenient.

The crane is entirely self-contained, being propelled backward or forward, and its position is very accurately adjusted by the winch gear shown on the under-carriage.

The price of these cranes, without the rivetter, varies from £80 to about £120.

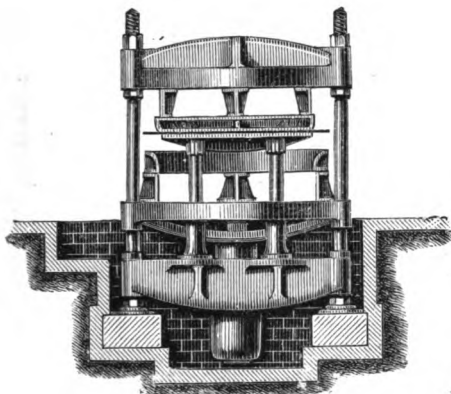

Fig. 3086.

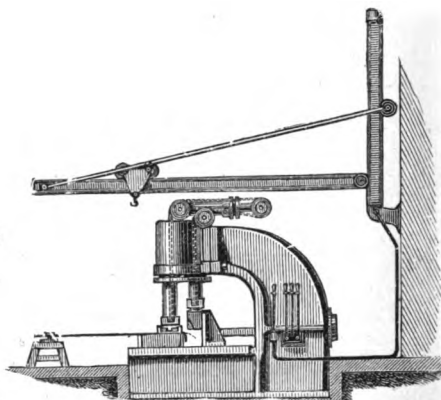

Fig. 3087.

HYDRAULIC FLANGING PRESSES.—The machine Fig. 3086, is recommended for flanging plates of moderate dimensions, such as are used for stationary or locomotive boiler work, where there is enough repetition to justify the outlay for dies.

The dies for these machines should be the full size of the plate to be flanged, so that the operation will be completed *in one heat*.

The presses have one or more flanging rams according to size and, in addition to these, they are provided with four other rams which serve (amongst other purposes) to prevent the plate from buckling.

The dimensions given are the maximum the machines will take in, and the prices do not include dies, moulds, or blocks for flanging.

PRICES OF HYDRAULIC FLANGING PRESSES, Fig. 3086.

To flange diam. up to	2ft. 6in.	3ft. 6in.	5ft.	7ft.	8ft. 6in.	8ft. 6in.	8ft. 6in.
„ thickness up to	½in.	¾in.	¾in.	¾in.	¾in.	1in.	1¼in.
Price of machine ...	£187	£235	£450	£580	£665	£740	£810

The cost of packing for shipment and delivery f.o.b. is 5 per cent.

HYDRAULIC PROGRESSIVE OR “SECTIONAL” FLANGING MACHINES, of the type indicated in Fig. 3087, flange plates mechanically, in exactly the same manner as when the work is done by hand, excepting that a steady continuous pressure is substituted for intermittent blows, and the work leaves the press free from the hammer marks incidental to flanging by hand.

The cost of dies and blocks (not included in the subjoined prices) is very small, and this machine is available for a wide range of Marine Boiler, and other work, too varied to justify the outlay for Dies, &c. required for the press last referred to, but by coupling the two vertical rams, this machine will turn out a great deal of work similar to that done in dies by the machine Fig. 3086.

In some cases a bottom cylinder is added at an extra cost of £30 to £45.

The cost of spiral gear for flanging Adamson seams is £40.

HYDRAULIC CRANES of the type indicated in Fig. 3087, are extremely useful for manipulating the work and are found to be an important adjunct to the press.

The subjoined prices include all appliances and the crane ready to fix to a wall or other structure.

PRICES OF PROGRESSIVE FLANGING MACHINES, Fig. 3087.

Depth of gap feet	3	4	4	4
Height ,, "	4	4	5	5
Thickness of plate flanged inch	$\frac{3}{4}$	1	$1\frac{1}{2}$	$1\frac{1}{2}$
Price of machine	£440	£505	£635	£865

The cost of packing for shipment and delivery f.o.b. is 5 per cent.

PRICES OF HYDRAULIC CRANES AS Fig. 3087.

Power of crane... .. tons	2	3	4	5
Range of lift feet	4	4	5	5
Price of crane	£105	£115	£135	£160

The cost of packing for shipment and delivery f.o.b. is 5 per cent.

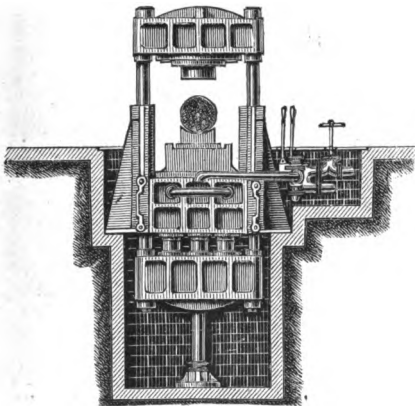

Fig. 3088.

HYDRAULIC FORGING

PRESSES range in power from 50 to 5,000 tons, when worked from the same Accumulator as supplies the rivetters and tools at a pressure of 1,500 lbs. per square inch.

The engraving Fig. 3088, represents one mode of construction which admits of the hydraulic cylinders being below the floor level, so that the overhead or other travelling crane, can readily bring the work to the press and manipulate it. The levers and appliances for regulating the pressure, &c. are arranged to afford every facility in operating the machine.

As almost every installation for forging by hydraulic pressure, has to be designed to fulfil certain special conditions, estimates of cost cannot be prepared without accurate data as to the nature and dimensions of the work for which the plant is required, the quantity to be turned out in a given time, etc.

HYDRAULIC SMITHS' HAMMERS are made to exert a pressure up to 30 or 40 tons and, being entirely self-contained, they require no foundations and can be worked in any position.

The prices of these tools vary from about £85 to £150, and they are used with great advantage on board ship, for Bridge work done in situ, and for many other purposes.

HYDRAULIC PLATE BENDING MACHINES supersede the ordinary bending Rolls, especially for heavy sections, they bend the plates to the extreme end and cannot be broken by overfeeding.

Several of these machines are at work bending plates, *cold*, $1\frac{1}{2}$ inch thick and 12 to 13 feet long.

In addition to the labour saving machines to which reference has been made, many others might be mentioned which are giving excellent results, such as:—

- Hydraulic Shearing Machines
- Hydraulic Punching Machines
- Hydraulic Bending and Straightening Machines
- Hydraulic Wheel Glutting and Welding Machines
- Hydraulic Spoke Forging and Bending Machines
- Hydraulic Bloom and Billet Shearing Machines
- Hydraulic Shell Forging Machines

Prices for these and other tools worked by hydraulic pressure will be supplied on receipt of particulars of the work to be done, also

Hydraulic Mains, Coils, Walking Pipes and all accessories for hydraulic machines.

TWO HUNDRED TONS HYDRAULIC WHEEL PRESS WITH POWER PUMPS.—This plant, recently delivered, is similar to Fig. 3088A in general arrangement, but some details have been modified to completely adapt the tool for the conditions it had to fulfil.

The machine takes in solid wheels up to 38 in. diameter and railway wheels, with spokes, up to 72 in. diameter and, as it has to force on or take off wheels for both broad and narrow gauge stock, the under carriage for the cylinder and the cross head are arranged to run on either gauge. The cross head is adjustable in height and the forged steel tension bars are of the lengths requisite for the gauges of wheels to be dealt with.

In lieu of the hand pumps and tank provided with the 100 tons press, Fig. 3088A, the pressure is supplied by double barrel hydraulic pumps of the type Fig. 3076; this is conveyed by a system of pipes to the wheel press and to other machines.

The ram is 10 in. diameter, the stroke is 18 in., and the machine is complete with efficient withdrawing apparatus, self-acting relief valve, &c.

The cost of the plant including the power driven pumps, hydraulic pressure gauge marked in lbs. per square inch and kilogrammes per square centimetre is £180.

The total weight is about 5½ tons and the cost of packing for shipment and delivery f.o.b. is 5 per cent.

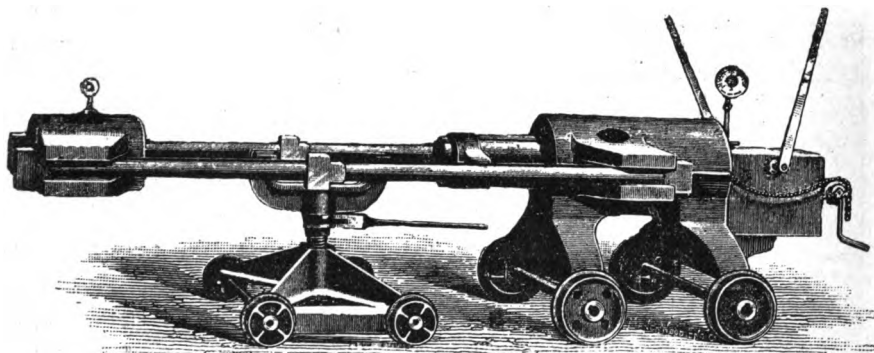

Fig. 3088A.

HYDRAULIC WHEEL PRESS.—Machines of this type are made of all powers and to fulfil many conditions, but that illustrated is adapted for most of the work done by such tools.

ONE HUNDRED TONS PRESS, represented by Fig. 3088A, has a ram of 10 in. diameter and a stroke of 18 in. and will force two locomotive or railway carriage or wagon wheels on their axles at one operation, or will take off one wheel at a time.

It consists of a hydraulic cylinder with cross head fixed on a carriage with plain or flanged travelling wheels—usually the latter and for a narrow gauge. The pump tank is attached to the travelling carriage and is complete with a pair of gun metal hydraulic pumps worked by hand lever, safety valve, hydraulic pressure gauge, pitch chain gear for withdrawing the ram, &c.

The intermediate carriage which supports the tension bars is adjustable vertically by screw and ratchet gear; the tension bars are of forged wrought iron or mild steel, with heads to fit the cross head, &c., as indicated in the engraving.

FIFTY TON PRESS.—This is similar in principle to that above described, but the ram is 7 in. diameter and the stroke is 9 in. The ram is withdrawn by screw, the press is arranged to work without the screw elevator on the intermediate carriage and it is adapted to take off or force on one wheel at a time.

To ensure the suitability of the press, it is desirable to send drawings or full details of the wheels for which it is required, and the maximum pressure to be developed.

PRICES OF HYDRAULIC WHEEL PRESSES.

Power of press tons	50	100
Price	£45	£95

The cost of packing for shipment and delivery f.o.b. is 5 per cent.

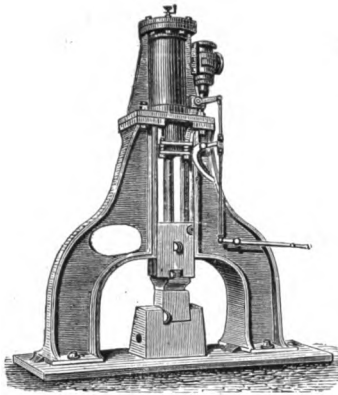

Fig. 3089.

DOUBLE STANDARD DOUBLE ACTING STEAM HAMMERS.—Fig. 3089 illustrates a three-tons steam hammer, single or double-acting, with cast iron frames but, if desired, these are constructed of mild steel plates at a relatively small extra cost, and the same type of hammer is made of all powers from 1 to 5 tons. The arrangements for working single or double-acting are those well known, and consist of appliances for instantly shutting off steam from the top of the cylinder to work single-acting or for admitting it to both sides to work double-acting.

The standards are accurately planed and fitted to the base plate, and ample bearing surfaces are provided in the slides of the tup and the side frames.

These hammers work self-acting or by hand, and all are tested in steam before delivery.

The following list gives prices up to 2 tons, and over that power they must be subject to special quotations.

PRICES OF DOUBLE STANDARD STEAM HAMMERS, Fig. 3089.

Power of hammer	tons	$\frac{1}{2}$	$\frac{3}{4}$	1	$1\frac{1}{2}$	2
Diameter of cylinders	in.	12	$13\frac{1}{2}$	$14\frac{1}{2}$	$16\frac{1}{2}$	19
Length of stroke	in.	27	$30\frac{1}{2}$	33	39	48
Width between standards ..	ft.	5	$5\frac{3}{4}$	$5\frac{3}{4}$	$7\frac{1}{2}$	$9\frac{1}{4}$
Price with anvil block	£195	£260	£320	£487	£580
Approximate weight	tons	$9\frac{1}{2}$	$14\frac{1}{2}$	18	27	35

The cost of packing for shipment and delivery f.o.b. is 5 per cent.

SINGLE STANDARD DOUBLE ACTING STEAM HAMMERS, open on three sides as indicated in Fig. 3090, but differing from it in the undernamed details of construction, are made of all powers from 3 to 60 cwt.

The piston rod is forged with the lower end enlarged to take the hammer face, which is secured by a dovetail and cotter, for the purpose of readily changing the faces for special work.

The smaller sizes are usually made with the sole plate and standard in one piece, but the largest powers have separate sole plates and, in all cases, foundation drawings will be supplied to suit the nature of the strata on which the hammers will be erected, accurate description of which should be provided.

These hammers are double-acting and are sent out complete with valve gear, specially designed steam stop valve, drip cocks, lubricators, &c., and are tested in steam before delivery.

PRICES OF SINGLE STANDARD STEAM HAMMERS.

Power of hammer	cwts.	3	4	5	6	8	10	$12\frac{1}{2}$
Diameter of cylinder	in.	9	10	11	12	13	14	15
Length of stroke	in.	20	20	24	24	27	30	30
Price with hand motion	£69	£76	£87	£94	£123	£164	£176
„ „ self-acting motion	£78	£85	£98	£104	£134	£177	£190
Approximate weight	tons	$3\frac{1}{2}$	$3\frac{3}{4}$	$4\frac{3}{4}$	$5\frac{1}{2}$	$7\frac{1}{2}$	$10\frac{1}{2}$	$10\frac{3}{4}$

PRICES OF SINGLE STANDARD STEAM HAMMERS FOR FORGES.

Power of hammer	cwts.	15	20	25	30	40
Diameter of cylinder	in.	$15\frac{1}{2}$	18	19	21	21
Length of stroke	in.	36	36	42	48	54
Price with hand motion	£255	£297	£325	£515	£600
Approximate weight	tons	$14\frac{1}{2}$	$17\frac{1}{2}$	$19\frac{1}{2}$	31	37

The cost of packing for shipment and delivery f.o.b. is 5 per cent.

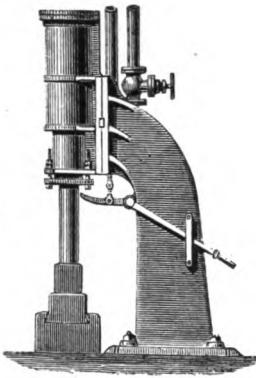

Fig. 3090.

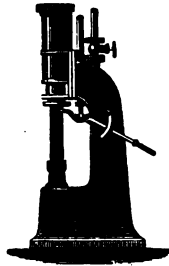

Fig. 3091.

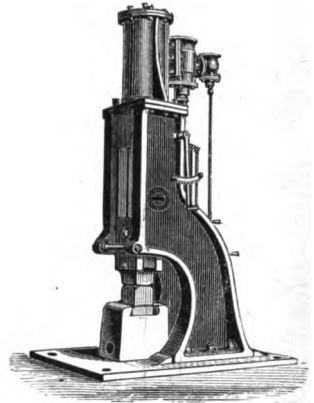

Fig. 3092.

SINGLE STANDARD DOUBLE ACTING STEAM HAMMERS.—Figs. 3090 and 3091 represent the type in general use for miscellaneous forgings, and Fig. 3092, that specially adapted for smith work and for stamping.

STEAM HAMMERS as Fig. 3090 are made to work self-acting or by hand, and of all powers from 1½ cwt. to 20 cwt., the “power” being that due to the dead weight of the piston and head, without taking into account the extra power exerted when steam is admitted on the top of the piston, as in working double-acting.

The anvil blocks are independent of the standards and are fixed on foundations, drawings for which will be supplied if desired.

The piston and piston rod are forged in one piece, and the hammer face and the anvil block are made of cast steel—The valve gear is of the most durable construction, and the self-acting gear can be instantly changed to hand motion whenever desired.

The subjoined prices include valve gear, special steam stop valve, drip cocks, lubricators, &c.

PRICES OF STEAM HAMMERS, Fig. 3090.

Power of hammer cwts.	1½	2	3	4	5
Diameter of cylinder in.	6	7	9	10	11
Length of stroke in.	14	14	20	24	24
Boiler H. P. required	2	2½	3	4	5½
Suitable for shafts in diameter ... in.	2½	3½	4	5	6½
Price with hand motion	£44	£48	£60	£70	£84
“ “ self-acting motion	£52	£56	£70	£80	£95
Approximate weight cwts.	32	38	63	70	94
Power of hammer cwts.	6	8	10	15	20
Diameter of cylinder in.	12	12½	14	15½	18
Length of stroke in.	24	27	30	36	36
Boiler H. P. required	4½	5	6½	10	12
Suitable for shafts in diameter ... in.	7	8	9	11	12
Price with hand motion	£94	£125	£170	£200	£270
“ “ self-acting motion	£105	£136	£182
Approximate weight tons	5½	7½	9½	13½	17

The cost of packing for shipment and delivery f.o.b. is 5 per cent.

THE STEAM HAMMERS illustrated by Fig. 3091, are double-acting and generally similar to those last referred to, but the anvil block is carried on the projecting base which forms part of the standard, as shown.

Hammers of this type require but little foundation, and the smaller powers can be provided with treadles, worked by the foot so that the Smiths' hands may be free to manipulate the work, and thus dispense with an assistant. The treadles are connected with the valve gear, one being used for working double-acting and the other for giving the dead blow. This motion is specially advantageous for stamping, swaging, making "drop forgings" &c., when the hammer should be, as far as possible, under the sole control of the forgerman.

PRICES OF STEAM HAMMERS, Fig. 3091.

Power of hammer	cwts.	1	1½	2	3	4
Diameter of cylinder	in.	4½	6	7	9	10
Length of stroke	in.	12	14	14	18	18
Price with hand motion	£38	£42	£46	£62	£69
" " self-acting motion	£45	£49	£53	£72	£79
" " treadle motion	£43	£47	£51	£70	£77
Approximate weight	tons	½	1½	1½	2	2½

The cost of packing for shipment and delivery f.o.b. is 5 per cent.

STEAM HAMMERS of the construction indicated in Fig. 3092, are specially adapted for stamping and die forging, and have the large guiding surfaces required to withstand the severe side strains incidental to these operations, and to produce accurate work; they are however equally available for ordinary Smiths' work.

These hammers are single and double-acting, automatically or by hand, and special provision is made for rapidly changing the faces of the dies. The length of stroke can be varied whilst the hammer is in motion, and the three smaller sizes—which may be run at any speed up to about 300 blows per minute—can be worked by treadle motion in the same manner as Fig. 3093, see description.

Each hammer is tested and is sent out complete with steam stop valve, lubricators, drip cocks, &c.

PRICES OF STEAM HAMMERS, Fig. 3092.

Power of hammer cwts.	2	1½	2	4	5	6	8	10	15
Diameter of cylinder in.	4½	6	6½	8	9	10	11	12	13½
Length of stroke .. in.	11	13	14	18	21	21	24	27	30
Price of hammer ..	£50	£75	£82	£98	£130	£145	£186	£209	£250
" with treadles ..	£58	£84	£92
Approx. weight .. tons	1	1½	2	3½	5	5½	6½	8½	13

The cost of packing for shipment and delivery f.o.b. is 5 per cent.

THE DUTY OF STEAM HAMMERS, given in the list on the preceding page, is intended to be useful to persons who are not familiar with the use of these tools. This data must be understood to refer to conditions where there is an ample supply of high pressure steam and that the forgerman is familiar with his work.

If these conditions do not exist, or the means of manipulating the forgings are deficient, some allowance in the sections of the forgings should be made.

In all cases, however, with these as with all other machines it is desirable that they should have ample power and weight for the largest work required.

FORGE CRANES of proportions equal to dealing with the largest work for which the hammer is adapted, afford such facilities in manipulation and so much economy in time and in cost of production, that it seems singular they are not universally adopted. Cranes for this purpose are usually arranged to be worked by the Forgerman, but the conditions they have to fulfil vary so widely that, reliable estimates of cost cannot be made without information as to the kind of work to be done, the nature of the attachments (if any) available, &c. In any case the cost of such a crane forms a small item in the total outlay for the hammer and its accessories, and the Author's experience is that, it is almost indispensable in works where economy in the cost of production is seriously

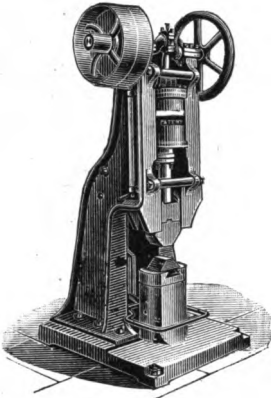

Fig. 3093.

PNEUMATIC HAMMERS of the type Fig. 3093, are adapted for general smiths' work and for the production of almost any kind of small forgings, files, tools, parts of agricultural implements, &c.

The hammer is driven by a belt as shown, and the force of the blow or the number of strokes, which may be from 150 to 500 per minute, are regulated by a lever worked by the treadle or by hand; this also controls the length of stroke, so that the hammer oscillates, without striking the anvil, whilst work is being changed or is moved from one die to another.

The power absorbed by this system of forging is very much less than that required to work a steam hammer, and it is preferable to the latter for production of forgings which require rapidly repeated blows, of equal or varying intensity.

PRICES OF PNEUMATIC HAMMERS, Fig. 3093.

Power of hammer	cwts.	$\frac{3}{4}$	$1\frac{1}{2}$	3	5
Price of hammer	£68	£80	£105	£135
Approximate weight	tons	2	$2\frac{1}{2}$	$3\frac{1}{2}$	$4\frac{1}{2}$

FULCRUM DROP HAMMERS may be mentioned as being useful for some kinds of forging, for planishing copper or other metals, flanging, &c. The force of the blow can be regulated within wide limits, but not whilst the hammer is running, as the Pneumatic hammer above referred to can be.

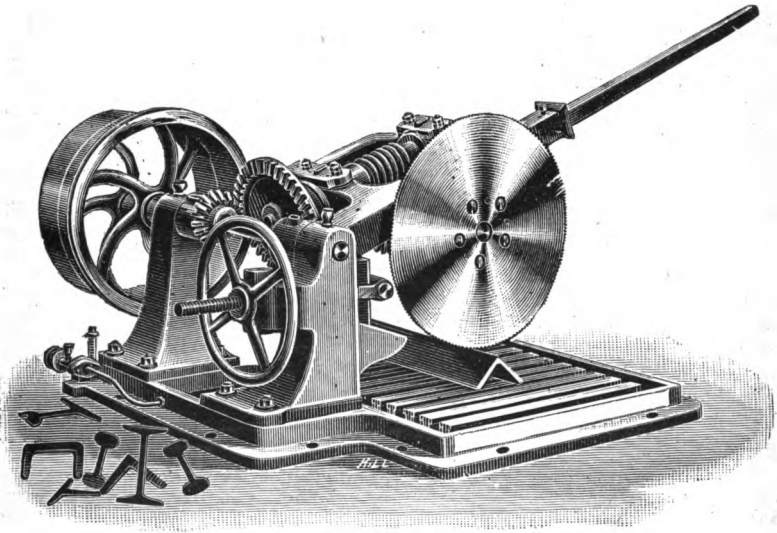

Fig. 3094.

COLD IRON SAWING MACHINES.—The cost and the time occupied in cutting steel, iron, and other metal bars to dead lengths by smiths' work or by slotting, shaping,

or other machines, have been found so great, that various methods have been devised for doing this work expeditiously and to leave a smooth surface which requires no dressing, but, excepting for special purposes, the circular saw probably gives the most satisfactory result. Amongst the numerous arrangements for a self-acting feed motion, may be mentioned that with a positive screw in combination with a friction feed. But exception is taken to this type because the feed cannot adjust itself to variations in section and, as the speed must not exceed that required for the largest section, it follows that a small bar is cut just as slowly as one with large section. To take a familiar example—when cutting a round bar—the speed of feed is uniform, although the sectional area gradually increases from the outside to the centre. Where a large quantity of work is required and more especially if it is mainly of heavy section the feed should, undoubtedly, adjust itself to the section being cut, and, for the heaviest work; this is best attained by having a balance weight attached to the swinging frame which carries the saw spindle as hereafter described or as indicated in Fig. 3094.

These machines are adapted for all kinds of work within the limits given below and the feed may be automatic or by hand.

The base plate has T slots for securing the work, and it is provided with a pair of standards which carry the gear as well as the swing frame, this being pivoted in phosphor bronze bearings to give the saw the necessary rise and fall. The machine is driven by fast and loose pulley, motion being transmitted to the saw by bevil gear and a steel worm working with a phosphor bronze wheel, running in a bath of oil, on the saw spindle.

The feed motion is worked by hand, but if it is desired that this shall be automatic, weights are attached to the lever to the extent required to give the maximum rate of feed for a given section of metal. When the wedge block (shown in front of the standards) is released, the saw steadily enters the work; the wedge block is then run down the incline and is placed in position to act as a stop to regulate the depth of cut.

The saw is lubricated by a small pump provided for that purpose, and the bed is recessed to collect the lubricant.

Each machine is complete with saw, fast and loose pulley, striking gear, oil pump, spanners, &c.

PRICES OF COLD IRON SAWING MACHINES, Fig. 3094.

Diameter of saw	22in.	28in.	32in.
Will cut sections up to	12in. x 6in.	16in. x 7in.	20in. x 8in.
Ditto solid do.	5in.	7in.	9in.
Price of machine with saw	£50 10 0	£72 0 0	£86 10 0
Ditto saw sharpening apparatus... ..	£5 0 0	£5 10 0	£6 15 0
Approximate weight tons	1	1½	2

The cost of packing for shipment and delivery f.o.b. is 5 per cent.

COLD IRON SAWING MACHINE WITH AUTOMATIC FEED.—

A massive cast iron planed bed with T slots, carries a movable fence and the work to be cut. The saw spindle is rotated by a worm and wheel, the worm being driven by a steel shaft running the whole length of the bed and fitted with a sliding key-way and feather.

The automatic feed is obtained by counterweights which are attached to the saddle by two chains and are carried on grooved pulleys. The length of cut is adjusted by a screw, which also serves to set the saw back in the position required for commencing a new cut.

The machine is complete with fast and loose driving pulley, strap fork and guide, one circular saw, screw keys, &c.

PRICES OF COLD IRON SAWING MACHINES AS ABOVE DESCRIBED.

Diameter of saw	30in.	30in.	33in.
Will cut section up to	9in. x 6in.	12in. x 6in.	16in. x 9in.
Price of machine with saw	£52	£60	£85
Ditto with saw sharpening apparatus	£61	£70	£97
Ditto extra saws each	£5	£5	£8
Approximate weight cwt.	36	43	80

The cost of packing for shipment and delivery f.o.b. is 5 per cent.

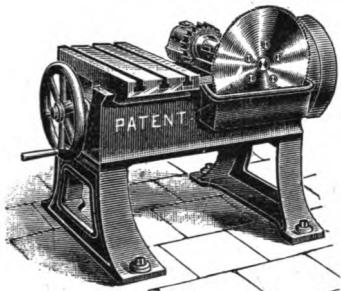

Fig. 3095.

COLD METAL SAWING MACHINE.—

Fig. 3095 illustrates a smaller machine than that last referred to and is used for cutting bars, angles, T and other sections up to about 4 inches by 4 inches.

The bed is carried on two standards and is provided with T slots for clamping the work. The saw spindle is driven by a phosphor bronze wheel and steel worm, and the work adjusted to it by the sliding saddle and hand wheel shown at the end of the machine. It is sent out complete with circular saw 15 inches diameter, fast and loose pulley, striking gear, screw keys, &c.

The price of the machine is £32 10 0

Ditto with saw sharpening apparatus £38 5 0

The approximate weight is 8 cwts. and the cost of packing for shipment and delivery f.o.b. is 5 per cent.

COLD METAL SAWING MACHINE FOR STEAM OR HAND POWER.—

This machine generally resembles that last described but has the lighter proportions required for cutting bars not exceeding 3 inches diameter, or other sections of equivalent area.

The saw is 12 inches diameter and the price of the machine whether adapted for working by steam or by hand power is £35 0 0

The cost of packing for shipment and delivery f.o.b. is 5 per cent.

HOT IRON SAWING MACHINE.—

The bed is of box section and has two brackets which carry the bearings for the saw spindle. The saw is driven direct by fast and loose pulley fixed between the above-named brackets, and the bed has planed V grooves to take the sliding table which carries the work.

The sliding table is provided with adjustable rests for holding the work to be cut and it is moved forward and backward by a hand lever, the brackets being removed when the machine is used for sawing plates.

The saw is securely encased and a trough is provided in the bed so that the saw may constantly run in water.

The price of the machine complete with saw 30 inches diameter (to run at about 1,400 revolutions per minute) starting gear, screw keys, &c. is £55 10 0

The cost of packing for shipment and delivery f.o.b. is 5 per cent.

SAW SHARPENING MACHINE for dressing the teeth of circular saws to cut

wood, slate, hot or cold iron, steel or other metals, consists of a standard of box section which carries the emery wheel for sharpening the saws and the whole of the driving and adjusting gear. These machines will sharpen 60 teeth per minute and constant attendance is not necessary. The adjustments to suit any diameter of saw (within the under-named limits) or any pitch of tooth, are easily made and the saw does not lose its temper by undue pressure of the emery wheel. It follows therefore, that the circumference is truly maintained and the teeth dressed with complete regularity.

PRICES OF SAW SHARPENING MACHINES.

To take in any diameter from	6in. to 36in.	12in. to 60in.
Price of machine complete	£17 10 0	£20 0 0

Cost of packing for shipment and delivery f.o.b. is 5 per cent.

For prices of emery wheels see p 96.

BAR OR TUBE STRAIGHTENING MACHINES.—

Many forms of machines are in use for this purpose, but that illustrated appears to possess some advantages over those in common use.

The machine Fig. 3096 consists of a pair of side frames which carry the shafts and gear shown, and the recessed plate seen behind the bar, the whole being fixed on a low trolley.

The spindles to which the two spur wheels are keyed, have, respectively, a right and left hand thread cut on them and are connected by a strong cross bar, so that, when the wheels are revolved by the pinion on the cross arm spindle, the cross bar is advanced and presses against the shaft at a point where it is unsupported and so straightens it.

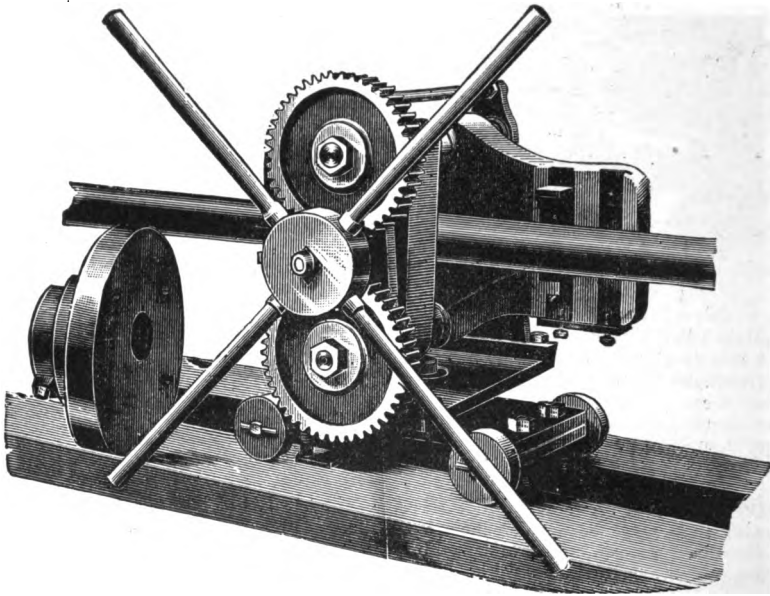

Fig. 3096.

When used for straightening shafting the machine may travel on a lathe bed, and, by using the catch plate—shown on the left—which grips the bar, it may be alternately revolved or released until it has been straightened, without stopping the lathe.

The carriage and bottom plate are made of wrought iron and each machine is complete with the slip catch plate above referred to, and V blocks for inserting in the slides in the recessed plate.

PRICES OF SHAFT STRAIGHTENING MACHINES, Fig. 3096.

To straighten shafting any diam. up to	2in.	2½in.	3½in.	4in.
Price of machine... .. .	£17 10	£19	£22	£24
Extra if fitted with gunmetal nuts	£1 10	£1 10	£2	£2
Approximate weight cwt.s.	2	2½	3½	4

The cost of packing for shipment and delivery f.o.b. is 7½ per cent.

BAR AND TYRE BENDING MACHINES with three hardened rolls, curve or straighten bars of various sections and true up welded tyres or rings of any diameter, much more economically and accurately than it can be done by any other method.

The three rolls have hardened surfaces and are carried between a pair of strong cast-iron side frames, supported by standards. Two of the rolls are connected by gear and the shafts work in fixed centres; the third roll is adjusted by a strong machine cut screw, to suit the section of the bar, and to give the required pressure.

The machine is provided with a handle for working by hand power and will bend flat bars up to 6 inches wide and 1½ inches thick, or H section up to 6 inch by 4 inch, as well as bars of T and L section.

The price of the machine is £25 0 0

The approximate weight is 9 cwt., and the cost of packing for shipment and delivery f.o.b. is 5 per cent.

TYRE BENDING MACHINES, similar in arrangement to those last referred to, but to work lighter sections of bars, are made to bend tyres of any diameter and of the following dimensions.

TYRE BENDING MACHINES.

To bend sections	4 in. × 1 in.	6 in. × 1½ in.	7 in. × 1½ in.
Price of machine	£6 10 0	£10 10 0	£15 0 0
Approximate weight ... cwt.	2	4	7

The cost of packing for shipment and delivery f.o.b. is 5 per cent.

TYRE DRILLING MACHINES, are made to take in wheels of any diameter and bore the tyres in place, that referred to being of the dimensions required to take in wheels up to 5 feet in diameter.

The machine consists of a bed supported on standards, as indicated in Fig. 3022. A fixed head stock with drill spindle, also a traversing mandril to take the wheel and secure it in any position on the bed, the vertical adjustment being given by a screw and capstan gear.

The bed is planed on the upper surface and has two \perp slots extending its whole length for securing the above-named wheel mandril carriage.

The fixed headstock is fitted with a steel spindle, which has a traverse of 6 inches by screw and hand wheel for advancing the drill. The spindle works in hard gun metal bearings, with loose caps and lock nuts, and is complete with fast and loose pulley, etc.

The price of the machine is £25 0 0

The weight is about 8½ cwt., and the cost of packing for shipment and delivery f.o.b. is 5 per cent.

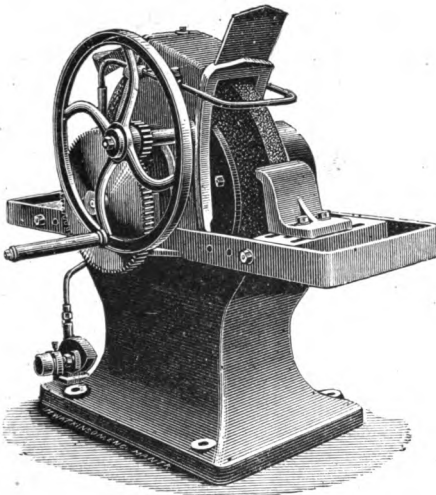

Fig. 3097.

EMERY WHEEL TOOL GRINDERS.—Fig. 3097 illustrates a

machine with emery disc 36 inches diameter, but the same construction is adhered to for all the sizes referred to in the subjoined list of dimensions and prices. The machine is sent out with a disc, of the size stated, mounted on a steel spindle carried in bearings in the frame, which forms a portion of the trough, fast and loose pulley for the smaller sizes and hand rest back and front; also a strap fork for guiding the belt and a small pump, strap driven, fixed on the base as shown, for water supply. The hand power reducing gear referred to below is useful when it is desired to rotate the disc slowly for the purpose of "truing it up" by cutters or a diamond tool.

The 36 inch machine can be fitted with a slide rest as Fig. 3101 at an extra cost of £9.

The cost of swivel bracket with four tool holders is £4 15 0, see Fig. 3101.

In all cases information should be given as to the purpose for which the machine is required, viz. :—Whether for grinding, engineers, brass finishers, or wood working tools.

PRICES OF GRINDERS, Fig. 3097.

Dimensions of emery disc inches	14in. by 2in	18in. by 2½in	24in. by 3in.	36in. by 3in
Size of driving pulley—diam. and width ,,	5in. by 2½in.	6in. by 2½in.	8in. by 2½in.	12in. by 4in.
Revolutions per minute	850	650	500	350
Price without hand reducing gear	£17 10 0	£22 15 0	£32 5 0	£51 10 0
„ with „ „ „ „ ..	£19 5 0	£24 10 0	£34 0 0	£54 0 0
„ extra disc mounted between turned plates... ..	£2 5 0	£4 15 0	£9 15 0	£21 0 0
„ extra disc turned ready for mounting	£1 15 0	£3 15 0	£7 15 0	£15 0 0
Approximate weight cwt.	5	6	8	16

The cost of packing for shipment and delivery f.o.b. is 5 per cent.

DOUBLE DISC TOOL GRINDERS.—The general arrangement is similar to that indicated in Fig. 3097, but two emery discs are mounted on the spindle and there are four hand rests. If desired these discs may be of different degrees of fineness, one being for grinding heavy and the other for light tools, scrapers, etc. In all cases the kind of tools to be ground should be stated.

PRICES OF DOUBLE DISC TOOL GRINDERS.

Dimensions of emery discs	24 in. by 3 in.	36 in. by 3 in.
" driving pulleys	10 in. by 4 in.	14 in. by 5 in.
Revolutions per minute	500	350
Price without hand reducing gear	£52 10 0	£78 0 0
" with " " " " extra	£1 15 0	£2 10 0
" of extra discs mounted between turned plates each	£9 15 0	£21 0 0
" " turned ready for mounting	£7 15 0	£15 0 0
Approximate weight tons	$\frac{3}{4}$	1 $\frac{1}{2}$

The cost of packing for shipment and delivery f.o.b. is 5 per cent.

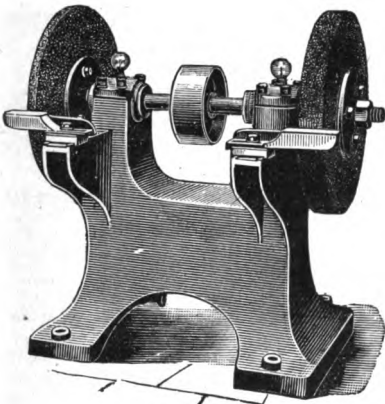

Fig. 3098.

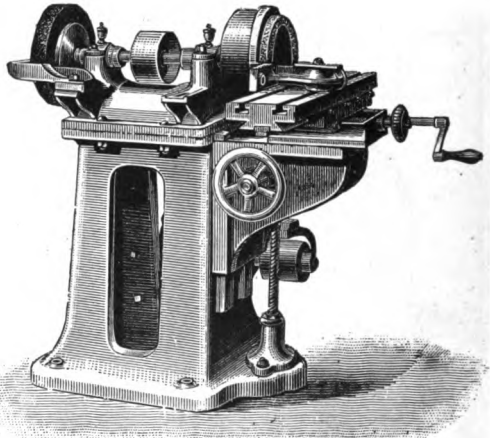

Fig. 3099.

THE GRINDING MACHINE, Fig. 3098, is used for cleaning or "fettling" castings and forgings and is fitted with two emery discs of different thicknesses carried on a steel spindle, and safety plates. The machines are complete with adjustable rests, driving pulleys, lubricators, &c.

PRICES OF GRINDING MACHINE, Fig. 3098.

Dimensions of wide disc.	16 in. by 2 in.	20 in. by 2 $\frac{1}{2}$ in.	30 in. by 4 in.	36 in. by 4 in.
" narrow disc.	16 in. by 1 $\frac{1}{2}$ in.	20 in. by 1 $\frac{1}{2}$ in.	30 in. by 2 $\frac{1}{2}$ in.	36 in. by 2 $\frac{1}{2}$ in.
" of pulley ...	8 in. by 3 $\frac{1}{2}$ in.	10 in. by 4 in.	10 in. by 4 in.	12 in. by 5 in.
Revolutions per minute...	1250	1000	660	550
Price of machine ...	£19 15 0	£28 0 0	£62 0 0	£84 0 0
" packing for shipment	£1 5 0	£1 10 0	£2 0 0	£2 5 0
Approx. weight cwts.	6	8	18	22

The cost of packing for shipment and delivery f.o.b. is 3 per cent.

THE GRINDING MACHINE, Fig. 3099 has an emery disc 12 inch diameter and 2 inch thick at one end of the steel spindle, the other end carrying an emery wheel 10 inch diameter and 1 inch thick provided with safety plates. The face wheel is surrounded by a safety ring, and the work is fixed on the adjustable table or on a compound slide rest and may be moved rapidly across the face of the wheel. An adjustable table is fitted to the other end if desired, and the machines are complete with countershaft, pulleys, strap guides, &c.

The dimensions of the pulleys on the countershaft are 6 inch by $3\frac{1}{2}$ in., and the speed of the latter is 830 revolutions per minute.

The price of the machine with one side table is	£32 0 0
Ditto of slide rest	£10 10 0
Ditto of nut divider	£3 15 0
Ditto of buffing wheel	£2 5 0

The cost of packing for shipment is £1 10 0, and the weight of the machine is about 7½ cwt.

DOUBLE BUFFING MACHINES for polishing metals are generally similar to those above described, but are fitted with wheels 36 inch diameter and 6 inch wide, which are covered with thick walrus leather dressed with emery and glue.

The price of these machines complete is £56 10 0, and the weight is about 9½ cwt.

TWIST DRILL GRINDERS, are provided with all appliances required to ensure accuracy in the angles of the drill faces, the lubricant is supplied by a small centrifugal pump, and there is space below the trough for drills, spare tools, &c.

The dimensions of the emery disc 18 inch by 2 inch, the driving pulley is 6 inch diam. and $2\frac{1}{2}$ inch wide, and it runs at about 650 revolutions per minute.

The price of a machine to grind drills $\frac{1}{4}$ inch to $1\frac{1}{2}$ inch is	£49 0 0
Ditto ditto $\frac{3}{8}$ inch to 2 inch is	£52 10 0

If with hand reducing gear, extra £1 15 0

The cost of packing for shipment is £1 10 0, and the weight of the machine is about 8 cwt.

MACHINE FOR GRINDING HARDENED OR CHILLED METALS with great accuracy after the work has been turned to nearly the required size, and after it has been chilled or hardened, or when soft, is used for finishing steel spindles, chilled iron rolls, copper rolls, &c. It can also be fitted with attachment for internal grinding for such purposes as finishing hardened steel bushes, bearings, &c.

The machine consists of a strong cast-iron bed which carries the sliding table and the grinding disc headstock. The sliding table is provided with an automatic reversing apparatus for any traverse up to 36 inches.

The grinding wheel head can be moved to any angle so that, with its cross slide, it can grind any degree of taper, and the headstocks on the sliding table can also be adjusted at any angle for grinding tapers; the fixed headstock has either live or dead centres. The back headstock can also be swivelled for internal tapers, and all working parts are covered to keep out the dust. The emery wheel spindle is driven by reverse cones, so that the peripheral speed can be kept constant with wheels from 12 inch to 6 inch diameter. The height of headstocks is $6\frac{1}{2}$ inch, and they admit 30 inch between centres.

Price including a set of 3 countershafts and spanners	£165 0 0
Extra for attachment for internal grinder	£13 10 0

The space occupied is about 7 feet 6 inches by 3 feet.

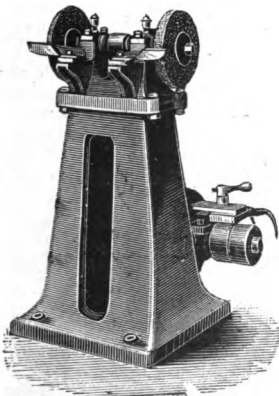

Fig. 3100.

DOUBLE DISC GRINDING MACHINES of the type Fig. 3100, are made with a pedestal, as shown, or on a frame for fixing to a bench, and the prices of both, complete with emery wheels suitable for general engineers' work will be found below. The bench machines have the driving pulley on the spindle as indicated in Fig. 3098.

Useful accessories for the larger machine referred to below are a buffing wheel, 14 inch by 3 inch, the cost of which is £2 10 0, and a circular saw, 8 inch diameter, fixed between turned plates, and suitable for cutting brass, &c. The cost of this is £1 0 0.

PRICES OF DOUBLE DISC GRINDERS, Fig. 3100.

Dimensions of wide disc	9 by 1½	14 in. by 2 in.
„ narrow discs	9 by ¾	14 in. by 1 in.
„ pulleys on countershaft	5 by 2½	6 in. by 3½ in.
Revolutions per minute for	600	725
Price of machine complete	£10 5 0	£18 0 0
„ without countershaft	£7 15 0	£15 0 0
Packing for shipment	£0 15 0	£1 0 0
Approximate weight cwts.	3½	5

PRICES OF DOUBLE DISC GRINDERS FOR FIXING TO BENCH.

Dimensions of wide disc	9 in. by 1½ in.	12 in. by 1½ in.	14 in. by 2 in.
„ narrow disc	9 in. by ¾ in.	12 in. by 1 in.	14 in. by 1 in.
„ pulleys	3 in. by 2½ in.	6 in. by 3½ in.	6 in. by 3½ in.
Revolutions per minute for disc	2200	1700	1450
Price of machine	£5 5 0	£8 10 0	£9 10 0
Packing for shipment	£0 6 0	£0 10 0	£0 12 0
Approximate weight cwts.	¾	1½	1½

The cost of extra discs will be found at p. 96

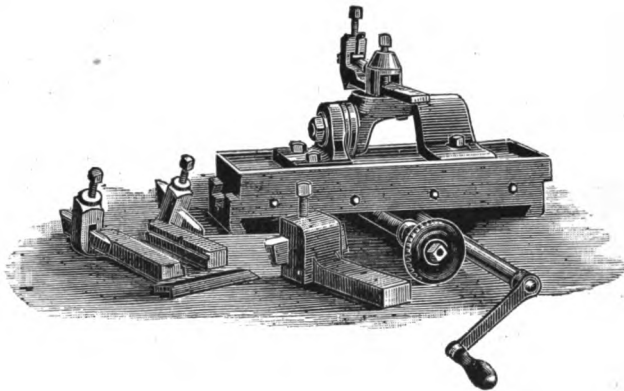

Fig. 3101.

THE SLIDE REST FOR GRINDERS, Fig 3101, with swivel brackets and tool holders is an accessory which will be found extremely useful for some kinds of work.

Price of the slide rest	£9 0 0
Price of swivel bracket and four tool holders	£4 15 0

EMERY DISCS WITH SQUARE EDGES, are turned ready for mounting between ordinary washer plates and the prices are as follows :—

Discs from 8 in. to 12 in. diameter ½ in. to ⅞ in. thick.	Price per lb.	.. 2/4
„ „ 12 in. „ 16 in. „ „ „ „	„ „	.. 1/9
„ „ 18 in. „ 36 in. „ ¼ in. and upward.	„ „	.. 1/3

Special prices are quoted for discs under 8 in. diameter.

WEIGHTS AND COSTS OF EMERY DISCS.—The approximate weight of a disc of any diameter or thickness, may be ascertained by multiplying the square of the diameter, in inches, by 0.09, the product being the weight in lbs. of a disc 1 inch thick, which, at the prices above mentioned, gives the approximate cost of the disc, and from this, the weight and cost of any other thickness is easily ascertained.

PRICES OF FACE WHEELS AS USED IN FIG. 3099.

Size inches	6 by 3 by 1 $\frac{1}{8}$	8 by 4 by 1	10 by 4 by 1	12 by 4 by 1
Price, mounted in safety chuck ...	£3	£4	£5 10	£6 10
„ of wheels only	10/- each	1/9 per lb.	1/9 per lb.	1/9 per lb.
Approximate weight of unmounted wheels lbs.	...	10 $\frac{1}{2}$	14 $\frac{1}{2}$	16
Size inches	12 by 4 by 2	14 by 4 by 1	14 by 4 by 2	16 by 6 by 2
Price, mounted in safety chuck ...	£7 10	£7 15	£9 5	£13
„ of wheels only	1/9 per lb.	1/9 per lb.	1/9 per lb.	1/9 per lb.
Approximate weight of unmounted wheels lbs.	18	30	33	55

PRICES OF EMERY DISCS WITH AND WITHOUT SAFETY MOUNTINGS.

Diam. of discs ins.	9	9	9	10	10	10	10	12	12
Thickness of discs „	$\frac{1}{2}$	1	1 $\frac{1}{2}$	$\frac{1}{2}$	$\frac{3}{4}$	1	1 $\frac{1}{2}$	$\frac{1}{2}$	$\frac{3}{4}$
Diam. of hole „	3	3	3	4 $\frac{1}{2}$	4 $\frac{1}{2}$	4 $\frac{1}{2}$	4 $\frac{1}{2}$	4 $\frac{1}{2}$	4 $\frac{1}{2}$
„ plates „	4 $\frac{1}{2}$	4 $\frac{1}{2}$	4 $\frac{1}{2}$	6	6	6	6	6	6
Price with plates	£0 12 6	0 16 3	0 18 3	0 17 0	0 19 0	0 1 0	0 1 5	0 0 19	0 1 2 6
„ without „	£0 4 0	0 7 6	0 9 9	0 4 3	0 6 6	0 8 9	0 12 6	0 6 9	0 9 9
Diam. of discs ins.	12	12	12	12	12	12	14	14	14
Thickness of discs „	1 $\frac{1}{2}$	$\frac{1}{2}$	$\frac{3}{4}$	1	1 $\frac{1}{2}$	2	1	1 $\frac{1}{2}$	2
Diam. of hole „	4 $\frac{1}{2}$	6	6	6	6	6	6	6	6
„ plates „	6	8	8	8	8	8	8	8	8
Price with plates	£1 12 0	1 8 9	1 11 6	1 14 6	2 0 2	2 6 3	2 0 0	2 8 9	3 2 13 6
„ without „	£0 19 9	0 5 9	0 8 6	0 11 6	0 17 6	3 1 3	0 16 9	1 5 3	1 13 6
Diam. of discs ins.	16	16	18	18	18	20	20	20	24
Thickness of discs „	1 $\frac{1}{2}$	2	1 $\frac{1}{2}$	2	2 $\frac{1}{2}$	1 $\frac{1}{2}$	2	2 $\frac{1}{2}$	1 $\frac{1}{2}$
Diam. of hole „	6 $\frac{1}{2}$	6 $\frac{1}{2}$	6 $\frac{1}{2}$	6 $\frac{1}{2}$	6 $\frac{1}{2}$	9	9	9	9
„ plates „	9	9	9	9	9	12	12	12	12
Price with plates	£3 2 9	3 13 6	3 13 6	4 9 0	5 3 6	6 13 0	5 9 9	9 6 6	6 6 0 9
„ without „	£2 5 0	1 14 0	2 5 0	2 19 0	3 14 9	9 2 10	0 3 7	0 4 3	0 3 17 6
Diam. of discs ins.	24	24	30	30	30	30	36	36	36
Thickness of discs „	2 $\frac{1}{2}$	3	2	2 $\frac{1}{2}$	3	4	2 $\frac{1}{2}$	3	4
Diam. of hole „	9	9	12	12	12	12	16	16	16
„ plates „	12	12	16	16	16	16	29	20	20
Price with plates	£8 12 6	9 18 3	12 8 9	14 7 6	16 7 6	20 8 3	20 14 0	23 6 0	28 15 0
„ without „	£6 9 0	7 15 3	7 17 6	9 15 6	11 15 9	15 16 3	13 10 3	16 2 0	21 11 3

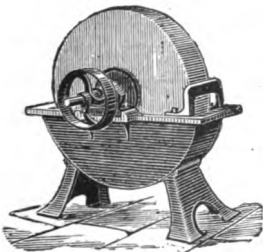

Fig. 3102.

GRINDSTONES, with Cast Iron Troughs, Fig. 3102.—These grindstones will be found to be well fitted throughout with a wrought iron shaft, having a square axle upon which the stone is mounted and firmly secured by the side plates and nut, and capable of being easily detached when it is required to mount a fresh stone. The stones are of the best quality and well adapted for grinding and sharpening knives, chisels, engineers tools, &c. Each stone is turned on face ready for use and when mounted in trough is complete with pedestals, fast pulley, tool rest and wrought iron handle.

PRICES OF GRINDSTONES, Fig. 3102.

Size of stone inches	30 by 6	36 by 6	36 by 8	42 by 6	42 by 8	48 by 8	48 by 10
Price complete with stone ..	£4 10	£5 15	£6 15	£7 15	£8 15	£10 10	£11 10
„ „ without stone	£3 15	£4 11	£5 8	£6 2	£6 17	£8 6	£8 15
„ stones only	15/-	£1 4	£1 7	£1 13	£1 18	£2 4	£2 15
„ hood and water drop case	17/6	20/-	£1 2	£1 3	£1 4	£1 6	£1 10
Approx weight with stone, cwt.	5½	8	10	10	12	15	20
„ „ without stone „	3	4	4½	7	7	9	10

NOTE.—The two largest sizes are fitted with fast and loose pulleys instead of handles.

An improved grinding slide for attachment by bolts to the above troughs for grinding plane irons, up to 24 inches long, can be fitted at an extra cost of £2 5 0.

PORTABLE SCREWING MACHINES.—The gear and working parts, in all these machines, are carried on a strong bed which may be mounted on an independent pedestal of box section, but they are usually fixed to an ordinary bench or on one which can be moved to where the work is required.

The dies are adjustable so that tubes may be screwed which are larger or smaller than the standard size, or the standard diameter may be maintained. An inexperienced workman will screw a full thread on pipes of any length, or of any diameter within the range of the machine, by one cut of the dies, provided that no dirt or “swarf” is left in them and that they are well supplied with good oil.

The dies are easily removed and are sharpened by being ground on a stone.

The appliances for gripping the pipe or bolt are self centring, and the machines for screwing small sizes can be provided with gear for working a speed three times that required for the larger sizes.

PORTABLE PIPE SCREWING MACHINE Fig. 3106.—This machine will screw pipes of any length and has an open top vice which allows bends, short, or irregular shaped pieces to be screwed.

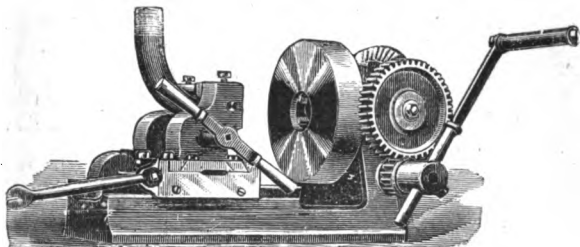

Fig. 3106.

The jaws of the vice above referred to come close up to the dies and, by adjusting these, any variation in the diameter of the tubes is easily dealt with and long screws or tight joints may be made with equal facility.

The high speed gear for small sizes is included in the subjoined prices and each machine is carefully tested before delivery.

PRICES OF PIPE SCREWING MACHINES, Fig.

	WITHOUT Stand.	WITH Stand.
For screwing tubes, 1, 1½, 1¾, 1¾, 2 ins.	£13 10 0	£15 15 0
Ditto ½, ¾, ¾, 1, 1½, 1½, 1¾, 2 ins.	£15 0 0	£17 5 0
Ditto 2, 2½, 2½, 3 ins.	£26 0 0	£29 0 0
Ditto 1, 1½, 1½, 1¾, 2, 2½, 2½, 3 ins.	£27 0 0	£30 0 0
Ditto 2, 2½, 2½, 3, 3½, 4	£38 10 0	£42 10 0
Ditto 1, 1½, 1½, 1¾, 2, 2½, 2½, 3, 3½, 4 ins.	£40 0 0	£44 0 0
Ditto 3, 3½, 4, 4½, 5 ins.	£50 0 0	£54 0 0
Ditto 2, 2½, 3, 3½, 4, 4½, 5 ins.	£52 10 0	£56 10 0

PRICES OF EXTRA ACCESSORIES.

For machines screwing up to	2 in.	3 in.	4 in.	5 in.
Extra dies right or left hand	15/-	20/-	30/-	50/-
Cutting off apparatus	30/-	40/-	55/-	75/-
Pulleys for steam power	50/-	60/-	70/-	70/-
Overhead motion	100/-	120/-	150/-	150/-

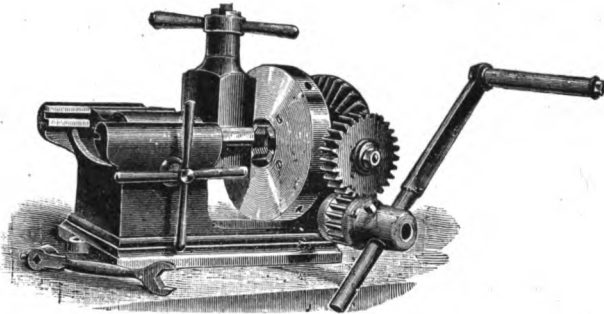

Fig. 3107.

PIPE SCREWING MACHINE Fig. 3107, is similar in general arrangement to those last referred to, excepting in the form of the gripping appliances. These are self-centring and do not distort or split the tubes.

The extra cost of the high speed motion for screwing small work is £0 10 0 for any size of machine.

PRICES OF PIPE SCREWING MACHINES, Fig. 3107.

	WITHOUT Stand.	WITH Stand.
For screwing tubes $\frac{1}{2}$, $\frac{3}{8}$, 1 ins.	£7 10 0	..
Ditto $\frac{1}{2}$, $\frac{3}{8}$, $\frac{1}{2}$, $\frac{3}{4}$, 1 ins.	£8 0 0	..
Ditto 1, $1\frac{1}{2}$, $1\frac{3}{4}$, $1\frac{1}{2}$, 2 ins.	£11 0 0	£13 5 0
Ditto $\frac{1}{2}$, $\frac{3}{8}$, $\frac{1}{2}$, 1, $1\frac{1}{2}$, $1\frac{3}{4}$, 2 ins.	£12 10 0	£14 15 0
Ditto 2, $2\frac{1}{2}$, $2\frac{3}{4}$, 3 ins.	£23 0 0	£26 0 0
Ditto 1, $1\frac{1}{2}$, $1\frac{3}{4}$, 2, $2\frac{1}{2}$, 3 ins.	£24 0 0	£27 0 0
Ditto 2, $2\frac{1}{2}$, $2\frac{3}{4}$, 3, $3\frac{1}{2}$, 4 ins.	£34 0 0	£38 10 0
Ditto 1, $1\frac{1}{2}$, $1\frac{3}{4}$, $1\frac{1}{2}$, 2, $2\frac{1}{2}$, $2\frac{3}{4}$, 3, $3\frac{1}{2}$, 4 ins	£36 0 0	£40 0 0

PRICES OF EXTRA ACCESSORIES.

	1 in.	2 in.	3 in.	4 in.
For machines screwing up to	1 in.	2 in.	3 in.	4 in.
Extra dies, right or left hand	12/-	15/-	20/-	30/-
Cutting off apparatus	25/-	30/-	40/-	55/-
Pulleys for steam power	40/-	50/-	60/-	60/-
Overhead motion	80/-	100/-	120/-	150/-

PORTABLE SCREWING MACHINES as Fig. 3107, but fitted with dies and other appliances for cutting screw bolt threads of the dimensions given below.

The dies are in halves and these being drawn apart when the thread has been cut the finished bolt is removed and a blank inserted ready for another operation, without the loss of time incidental to running back and the risk of possible damage to the dies.

The gripping gear is self centring and the dies are adjusted to insure uniformity in the diameter of the bolt or stud. The subjoined prices include a set of dies for each size of bolt or tube, also the high speed gear for screwing small sizes.

The prices of these machines and accessories are—

Price of machine to screw bolts $\frac{1}{2}$, $\frac{3}{8}$, $\frac{1}{2}$, $\frac{3}{4}$, $\frac{1}{2}$, $\frac{3}{8}$, $\frac{1}{2}$ and 1 in.	£14 0 0
If on cast iron pedestals, extra	£2 10 0
Extra dies and bolt holders for hexagon and square heads, per size	£1 0 0
Machine taps and tap holders, per set of 7	£3 0 0
Price of machine to screw bolts, $\frac{1}{2}$, $\frac{3}{8}$, $\frac{1}{2}$, $\frac{3}{4}$, $\frac{1}{2}$, $\frac{3}{8}$, 1, $1\frac{1}{2}$ and $1\frac{1}{2}$ in.	£17 0 0
Extra dies and bolt holders for hexagon and square heads, per size	£1 5 0
Machine taps and tap holders, per set of 9	£5 0 0

WOOD WORKING MACHINERY.

As the space available does not admit of this important branch of machine construction being at all adequately treated, the Writer must content himself with describing and (as far as possible) illustrating, the machines in general use, leaving a large number of others to be subjects for special correspondence and arrangement.

It is generally recognized that the cheapest machine tools are, by no means, always the most economical, and this is especially true with reference to wood working machinery. The working parts necessarily run at high speeds—not always under the best conditions in regard to supervision and maintenance—so that the first consideration should be excellence in design, proportions, materials and workmanship, rather than low initial cost.

The motive power for driving is not referred to, excepting only in regard to the *approximate* power required for each machine, but full information hereon will be found in the sections devoted to "Prime Movers," and this will be supplemented by plans, drawings, &c. of machinery and foundations, or for setting boilers to work with the refuse from the mill.

For overhead travelling cranes to command the entire area of the mill house, Derrick or other cranes for lifting and stacking timber, or capstans for hauling logs to the machines, see the section relating to "Hoisting Machinery."

If advice is desired with reference to the tools best adapted for the work, the arrangement of machinery, &c., the fullest possible information should be furnished as to the class of work to be done, the quantity to be turned out in a given time, the kind of timber to be worked, and such other data as will admit of accurately understanding the conditions to be fulfilled.

Amongst the machines referred to, inadequately, or not at all, are many types of

- Circular saw benches for special purposes.
- Reciprocating and treadle action cross cut saws.
- Timber, log, and deal frames of several types.
- Horizontal reciprocating saw frames.
- Band saws with travelling tables for opening out logs.
- Band saws with roller feed.
- Band saws and circular saw bench combined.
- Dimension sawing machines. Dovetailing machines.
- Panel planing and thickening machines.
- Planing, trying up, and sandpapering machines.
- Multiple horizontal and vertical drilling machines.
- Cask making machines of several types.
- Wheel making machines.
- Sleeper sawing, boring, and adzing machines.
- Copying and other special lathes to make facsimiles of cabinet or carpenters' joinery, gun stocks, wheel spokes, pick, hammer, or fork handles, &c.
- Moulding, shaping, and recessing machines.
- Machines to plane, punch, and finish blind laths.
- Machines to make cedar pencils, matches, match boxes, &c.

PORTABLE RACK SAW BENCH, Fig. 3108.—These machines have been designed with a view to facility in transport and re-erection, and are equally adapted for use in the saw mill, or for Colonial or similar work, where it is desirable that the machine should follow the clearing.

The heavy cast iron framing, generally used for saw mill benches, is dispensed with and the machinery is constructed for fixing on timber foundation beams provided by the purchaser.

The travelling tables, which carry the timber to be sawn, are about 35 feet long, these are built up of wrought iron and are in two parts, separated by the saw gate. The tables are supported on rollers with carriages, as shown, the fence is adjustable and the rate of feed can be varied to suit the different kinds of timber.

The driving gear, for all motions, is on one side of the bench, and is supported on timbers framed with the main beams which carry the saw and traversing tables.

The saw spindle which is of steel runs in hard gun metal bearings and is adapted for carrying a saw of any diameter up to 60 inches.

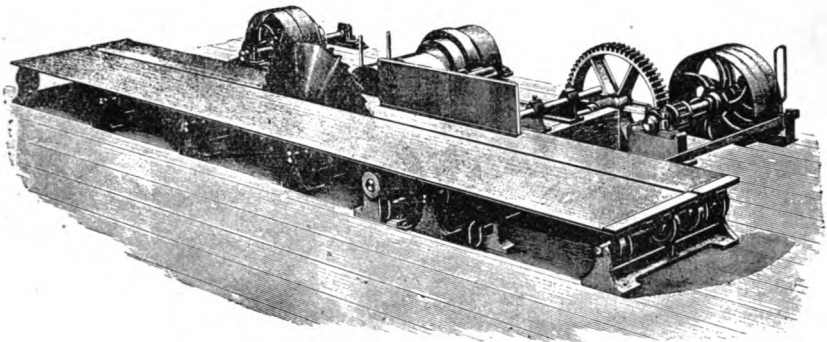
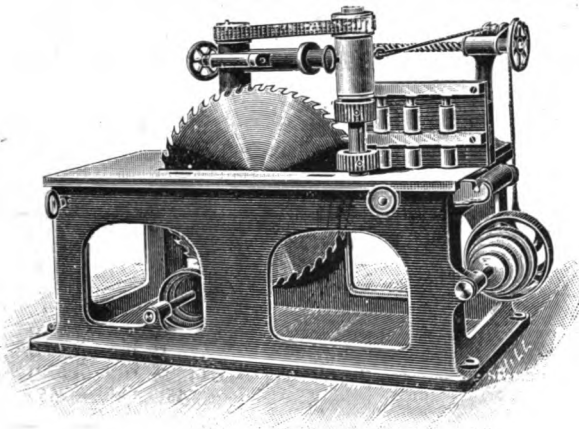

Fig. 3108.

The price of the machine complete, exclusive of saws is £100 0 0
 The power required to work it is 8 H.P. and the total weight is about 4½ tons.
 The cost of packing for shipment and delivery f.o.b. is 5 per cent.

RADIAL ARM ROLLER FEED SAW BENCH.—The machine Fig. 3109 is adapted for a wide range of work, and especially for cutting up sleepers or other cheap timber, and for packing cases, &c.



The radial arm swings on the pillar at the back of the table and on the side opposite to the fence, so that the front of the bench is free for returning the timber after each cut.

The arm is easily turned to one side, clear of the bench, when the rope feed is used for sawing logs, or when the bench is required for jobbing work.

Fig. 3109.

PRICES OF RADIAL ARM SAW BENCH, Fig. 3109.

Diameter of saw	36 in.	42 in.	48 in.
Length of table	5 ft. 6 in.	6 ft.	8 ft.
Width of ditto	2 ft. 9 in.	3 ft.	3 ft.
H.P. required	4	5	6
Price of bench	£65 0 0	£70 0 0	£75 0 0
Approximate weight cwts.	35	40	45

The cost of packing for shipment and delivery f.o.b. is from 5 to 8 per cent.

CONTINUOUS FEED SAW BENCH.—Fig. 3110 represents a machine with self acting continuous feed, adapted for general work and for sawing small logs, sleepers,itches, deals, &c.

The timber is fed by two plain rollers, one at each end of the table. Both these rollers are driven and, the weight of the timber together with the "draw" caused by the saw, when

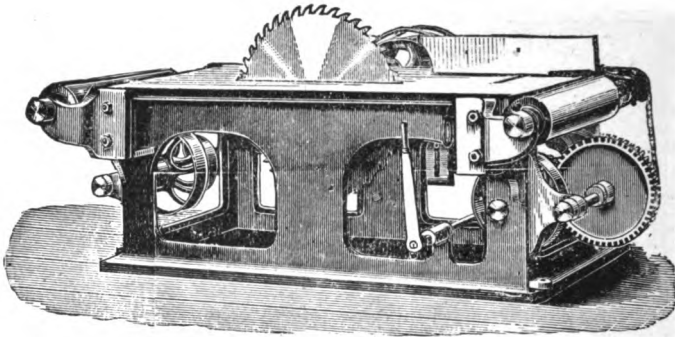

Fig. 3110.

cutting, provide a regular and efficient feed; if desired, the feed rollers can be made to reverse front and back of the machine. These can easily be made by the purchaser who will fix the rails, wheels, axles, and ironwork, the prices of which will be found below.

The machine is sent out complete with fast and loose pulley and all appliances, as shown, excepting saws, the prices for which are given.

PRICES OF CONTINUOUS FEED BENCH, FIG. 3110.

Diameter of saw	42 in.	48 in.	60 in.
Length of table	5 ft.	6 ft.	8 ft.
Width of do.	3 ft. 6 in.	3 ft. 6 in.	3 ft. 6 in.
H.P. required	4	6	8
Price of bench	£75 0 0	£80 0 0	£90 0 0
Do. saw	£4 15 0	£7 5 0	£18 0 0
Do. rails and ironwork for carriages	£14 0 0	£14 0 0	£14 0 0
Approximate weight cwts.	35	45	55

The cost of packing for shipment and delivery f.o.b. is from 5 to 8 per cent.

CIRCULAR SAW BENCH WITH RISING AND FALLING SPINDLE for sawing, cross cutting, tonguing, grooving, beading, and rebating, and for boring, is a generally useful tool to builders, contractors, landed proprietors, and others who have a large range of work, including joinery, but have not the space available for a number of special tools, or sufficient work to keep them profitably employed.

The table generally resembles that illustrated by Fig. 3109 and the parallel fence is adjustable to any angle, or can be turned clear of the table for cross cutting.

The saw spindle is adjusted in height by a hand wheel and gear, and it is so arranged that the saw can be easily removed and the cutter block fixed in its place, for tonguing, grooving, beading, and rebating. The two larger sizes of machines are provided with two speed pulleys so that the saw spindle can be driven at different speeds.

The boring auger is carried in the outer end of the saw spindle and the work is supported on a bracket, attached to the side frames and fitted with a sliding table with planed surfaces.

The machine is complete with fast and loose pulley, strap guide, screw keys, &c.

The prices of circular saws, cutter blocks and cutters, augers, &c., will be found under their respective headings.

PRICES OF SAW BENCH WITH RISING SPINDLE.

Diameter of saw	20	24	30	36
Length of table	4 ft.	5 ft.	5 ft. 6 in.	6 ft.
Width do.	2 ft.	2 ft. 6 ft.	2 ft. 9 in.	2 ft. 6 in.
H. P. required	2	3	4	4
Price of bench	£25 0 0	£30 0 0	£36 0 0	£45 0 0
Do. boring apparatus	£2 0 0	£2 0 0	£2 0 0	£2 0 0
Do. intermediate shaft	£3 0 0	£3 0 0	£5 0 0	£5 0 0
Approximate weight .. cwts.	18	20	27	33

The cost of packing for shipment and delivery f.o.b is from 5 to 8 per cent.

CIRCULAR SAW BENCH WITH RISING AND FALLING TABLE,

Fig. 3111.—The table is planed and is supported on a cast iron pedestal, of box section which carries the driving pulleys and all appliances for working the bench; no countershaft is required and the tool may be fixed in almost any position.

The table is guided by double slides and is quickly raised or lowered by the worm gear and hand wheel, shown in the engraving, and is held in position by this gear.

The fence turns over to leave the table free and a groove is planed in it to receive a cross cutting slide. The cost of the table with fence for straight or angle sawing will be found below.

The driving pulleys are below the table and the driving belt does not need to be altered.

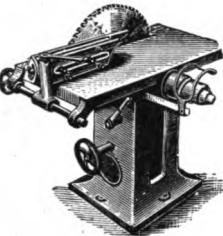

Fig. 3111.

The subjoined prices include fast and loose pulleys, belt guide, turn over fence, screw keys, &c.

PRICES OF CIRCULAR SAW BENCHES, Fig. 3111.

Diameter of saw	24 in.	26 in.	30 in.	36 in.
Length of table	4 ft.	4 ft.	4 ft. 6 in.	5 ft.
Width „	2 ft.	2 ft.	2 ft. 3 in.	2 ft. 6 in
Depth of cut	9 in.	10 in.	12 in.	15 in.
H. P. required	2	3	4	6
Price of bench	£19 10 0	£22 0 0	£26 10 0	£32 10 0
If with fence to bevil	£20 15 0	£23 5 0	£28 0 0	£34 10 0
Approx. weight cwts.	6	7	10	15

The cost of packing for shipment and delivery f.o.b. is from 5 to 8 per cent.

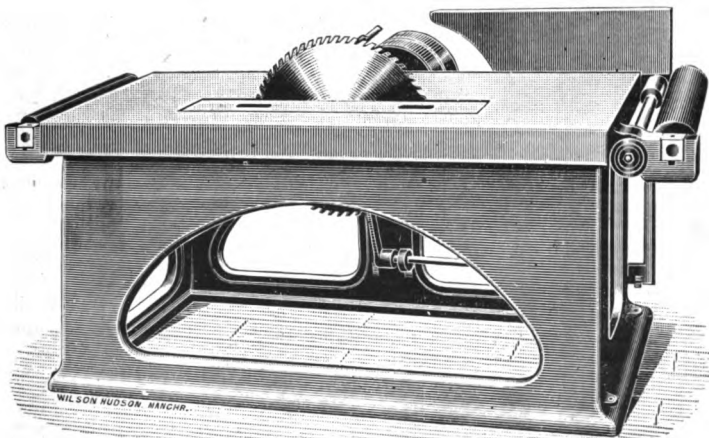

Fig. 3112.

CIRCULAR SAW BENCH, Fig. 3112.—The framework is usually made in one casting to ensure solidity and to avoid re-erection, but, for shipment or for transport over mountain roads, the sides and table are made separately and bolted together at destination.

The table is truly planed and the steel saw spindle, with lock nuts to take up wear, is arranged to be easily taken out for examination.

The end rollers support the timber and reduce friction when it is passing over the bench. The parallel fence is regulated by a hand screw and, when the end roller is removed, can be turned back, clear of the table, for cross cutting or for small work.

The separate cost of the end rollers and of a self-acting drag motion for drawing the timber up to the saw will be found below. For prices of circular saws see page

PRICES OF SAW BENCHES, Fig. 3112.

Diameter of saw	18 in.	26 in.	30 in.	36 in.	42 in.	48 in.
Length of table	4 ft.	4 ft.	5 ft.	5 ft.	6 ft.	8 ft. 9 in.
Width of table	2 ft.	2 ft.	2 ft. 6 in.	2 ft. 9 in.	3 ft.	3 ft. 2 in.
Depth of cut	6 in.	10 in.	12 in.	15 in.	18 in.	21 in.
H.P. required	1½	2	2½	3½	4½	6
Price of bench	£15	£17	£20	£24	£35	£44
Extra for rollers	£1 15	£2 5	£3	£3 10	£4	£5
„ drag motion	£9	£9 10	£10	£10 10
Approx. weight cwts.	6	8½	16	19	24	33

The cost of packing for shipment and delivery f.o.b. is 5 per cent.

PENDULUM CROSS CUTTING CIRCULAR SAWS are inexpensive but very useful tools in saw mills, especially those where much cross cutting in small sections is required, such as for box making, sashes, doors, &c.

The pendulum or swing frame, is of H section (usually about 6 feet long), and is suspended from a spindle carried in a pair of hangers which are secured to an overhead beam and counter weighted to return automatically.

The spindle has a fast and loose pulley, at one end, for the driving belt, and another centrally with the swing frame, from which power is transmitted by a belt to a smaller pulley fixed on the saw spindle at the lower end of the frame.

The work is placed on a wooden bench below the saw and is cross cut by drawing the saw forward by the handle provided for that purpose.

The price of a machine to carry a 24 in. saw is £18.

The weight is about 8 cwts.

The driving power required is about 2 horse.

The cost of packing for shipment and delivery f.o.b. is 8 per cent.

CIRCULAR SAW SPINDLE with cast iron frame for bolting to a timber table and thus form an inexpensive circular saw bench.

The spindle is of steel truly turned and fitted with fast and loose pulley, washer and adjustable lock nuts. The bearings are of hard gun metal constructed to withstand end thrust and are adjustable for wear. If desired the end of the spindle can be arranged for carrying boring tools.

PRICES OF CIRCULAR SAW SPINDLES.

Diameter of Saw	18 in.	24 in.	30 in.	36 in.	42 in.	48 in.
Price of spindle	£4 5	£5 5	£6	£6 15	£8	£9 15
Ditto saw	18-	£1 7	£2	£3 5	£4 15	£7 5
H.P. required	1½	3	4	5	6	7
Approximate weight cwts.	1½	2	2½	2½	2½	3½

The cost of packing for shipment and delivery f.o.b. is 5 per cent.

HORIZONTAL SAWING MACHINES of the type Fig 3113 are used for converting log or squared timber and are specially adapted for cutting hard or fancy woods.

The saw cuts in both directions and, being very thin, the waste is small, but perhaps the

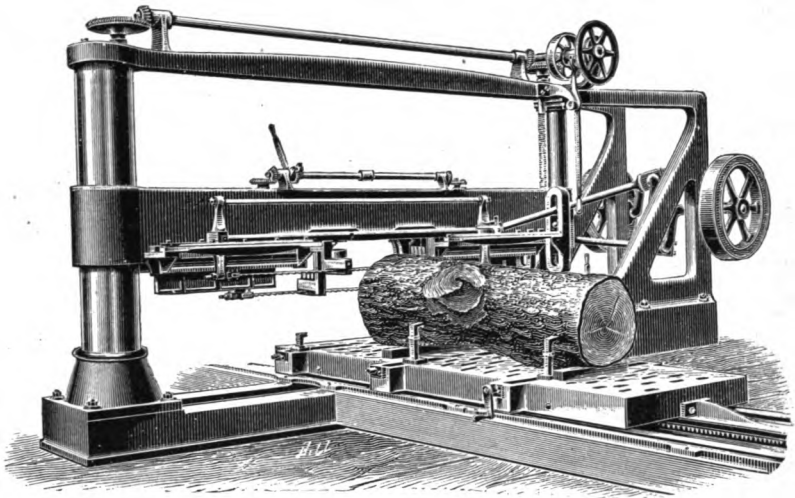

Fig. 3113.

most important feature is that, when cutting only one or two boards at a time, the timber can be examined and—as the “pattern” is developed—the boards can be appropriated to the purposes for which they are most suitable.

The machines are made to carry one or two saws; the swing frame carrying them reciprocates between the two standards, and all appliances are provided for accurately adjusting the height of the saws to suit the work.

The travelling bed to which the timber is clamped, as shown, is about 24 ft. long and is traversed forward to the saw by a self acting feed with variable speeds.

The driving power is transmitted by belt or direct from an engine attached to the machine, a very convenient arrangement when continuous work is required.

PRICES OF HORIZONTAL SAWING MACHINES FOR TWO SAWS, Fig. 3113.

Section of timber	24 in.	30 in.	36 in.	42 in.	48 in.
Price of machine	£300	£320	£340	£420	£440
Do. with engine	£400	£420	£450	£530	£550
Do. extra table per foot ..	£3 0 0	£3 0 0	£3 10 0	£4 0 0	£4 0 0
Do. of saws each	£0 9 6	£0 11 6	£0 14 6	£0 15 6	£0 18 6
Do. of buckles	£0 10 0	£0 10 0	£0 10 0	£0 10 0	£0 10 0
H.P. required	3	3	4	4	4
Approximate weight .. tons	9½	11½	13	14	15

The cost of packing for shipment and delivery f.o.b. is 5 per cent.

PRICES OF HORIZONTAL SAWING MACHINES WITH ONE SAW.

Sections of timber	24 in.	30 in.	36 in.	42 in.	48 in.
Price of machine	£220	£240	£270	£290	£310
Ditto with engine	£300	£320	£350	£390	£410
H.P. required	2	3	3	4	4
Approximate weight .. tons	6	8½	8½	9½	9½

The cost of packing for shipment and delivery f.o.b. is from 5 to 8 per cent.

The cost of extra table per foot, saws, buckles, &c., will be the same as for machine

Fig. 3113.

The extra cost of countershaft for belt driven machine of any size, is £10 for either type.

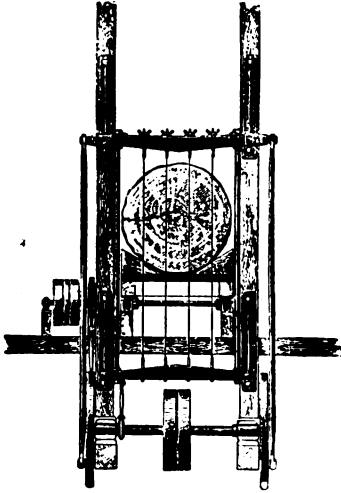

Fig. 3115.

BREAKING DOWN FRAMES WITH TIMBER COLUMNS, Fig. 3115.—The principles of construction are similar to those adopted in Fig. 3114, but timber is used for the standards, &c. instead of iron. This still further reduces the weight of parts, the heaviest package weighing considerably less than 10 cwt.

The machinery consists of the reciprocating frame to carry four saws, top and bottom guides for same, wrought iron connecting rods with gun metal bearings and strap head secured by gibs and cotters. The connecting rods are pivoted on steel pins fitted into discs on the two ends of the shaft which carries the driving and loose pulleys, as shown. This shaft runs in long gun metal bearings the pedestals for which form part of the sole plate and shoe for fixing the timber standards, thus ensuring the reciprocating and driving gear being always true with each other. Also the variable speed rack feed apparatus, rails, rollers and pedestals for a traverse of 30 feet, screw keys, &c. but no timber work, this being provided by the purchaser and made in accordance with drawings supplied with the machinery, or in advance of delivery.

PRICES OF MACHINERY FOR BREAKING DOWN FRAMES FOR TIMBER STANDARDS, Fig. 3115.

Section of log	36 in.	42 in.	48 in.	60 in.	72 in
H.P. required	8	10	10	12	12
Price of machinery	£160	£170	£180	£190	£200
„ saws, buckles and cotters	£1 15 0	£2 2 0	£2 8 0	£3	£3 6 0
Approx. weight .. tons	4½	4½	5	6	7½

The cost of packing for shipment and delivery l.o.b. is from 5 to 8 per cent.

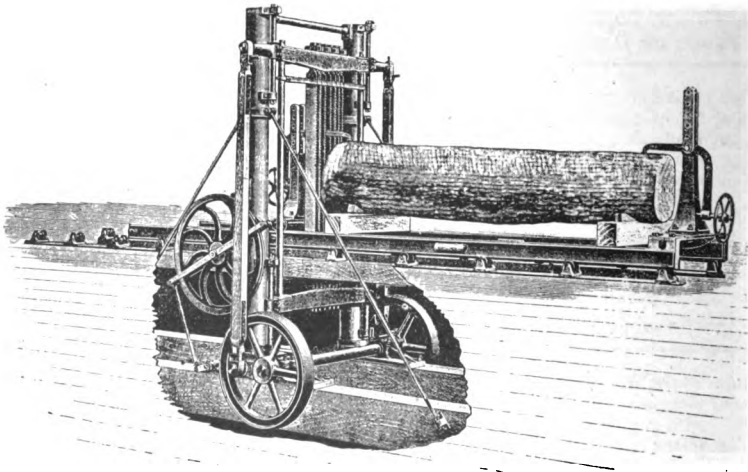

Fig. 3114.

PORTABLE BREAKING DOWN FRAME, Fig. 3114.—This simple and efficient machine has been designed with a view to great stability, and for facility of transport. The maximum weight of any part does not exceed 10 cwt., and the machine is easily dismantled and re-erected, so that it is peculiarly suited for use in the forest or in localities which are difficult

of access and, when used in conjunction with a circular saw bench, railway sleepers, scantlings, &c, can be delivered direct from the forest.

The frame will carry 12 saws and the machine can be driven from the fly wheel of a portable engine or from any other available motor, and every facility for re-erection is afforded by fixing the guides, shafts, &c. to the iron columns and the sole plates which support them.

The machine is complete with rails, rollers and pedestals for a traverse of 30 feet, clamping appliances, feed motion, double fly wheels, stays to column, screw keys, &c.

PRICES OF BREAKING DOWN FRAMES, Fig. 3114.

Sections of log	24 in.	36 in.	48 in.	60 in.
H. P. required	4	6	8	10
Price of machinery	£220	£260	£300	£330
Approx. weight tons	5	6	7½	8

The cost of packing for shipment and delivery f.o.b is from 5 to 8 per cent.

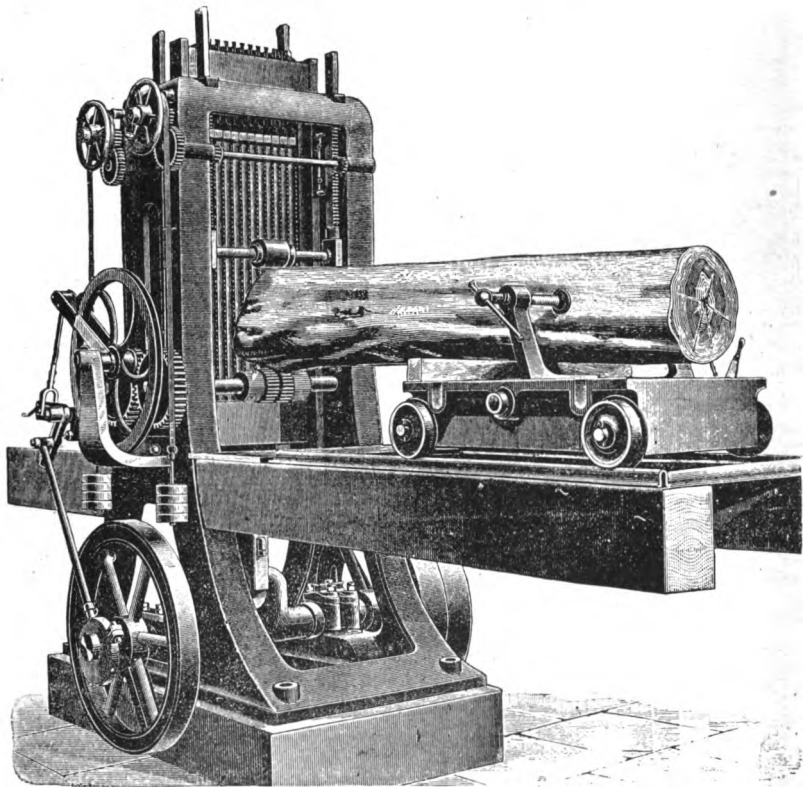

Fig. 3116.

TIMBER FRAME DRIVEN FROM BELOW.—The machine Fig. 3116, is constructed for erection on a light foundation of timber or masonry, occupying a minimum space below the mill floor and, if provided with deal cutting apparatus, the machine can be used as a double deal frame, or for sawing up logs as required.

The timber is fed into the frame by fluted rollers driven by silent ratchet wheel and has an efficient self adjusting pressure apparatus.

The machine is sent out with rails for a traverse of 30 feet, timber carriages with gripping apparatus, fast and loose pulley, strap guide, screw keys, &c.

PRICES OF TIMBER FRAME, Fig. 3116.

Section of log	16 in.	20 in.	24 in.	30 in.	36 in.
H.P. required	3	4	5	7	8
Price of frame	£200	£220	£265	£330	£380
Do. of saws and buckles	£0 14 0	£0 16 0	£0 17 6	£1 0 0	£1 3 6
Approximate weight .. tons	4½	6½	7	8½	11

The cost of packing for shipment and delivery f.o.b. is from 5 to 8 per cent.

UNDERDRIVEN SAW FRAME FOR BREAKING DOWN LOGS OR TIMBER.—A pair of side frames, which carry the whole of the machinery, are attached to a massive base plate as shown in Fig. 3116, but in this machine the reciprocating saw frame is worked by connecting rods coupled to balanced fly wheels on each side of the vertical frames, the fast and loose pulleys, to which power is transmitted from the engine or other motor, being fixed centrally on the fly wheel shaft.

This construction reduces the depth and cost of foundations, frequently an important consideration and, whilst tending to increase the stability of the machine, is the strongest form in which it can be used.

The travelling bed is, in all cases, 30 feet long and the feed is by rack gear worked from silent ratchet gear, and is admirably adapted for hard woods

PRICES OF BREAKING DOWN FRAMES.

Section of log	36 in.	42 in.	48 in.	60 in.	72 in.
H.P. required	8	9	10	12	14
Price of frames	£380	£400	£420	£440	£460
Do. of saws and buckles	£1 15 0	£2 2 0	£2 8 0	£3 0 0	£3 6 0
Approximate weight .. tons	12½	13½	14	15	16

The cost of packing for shipment and delivery f.o.b. is from 5 to 8 per cent.

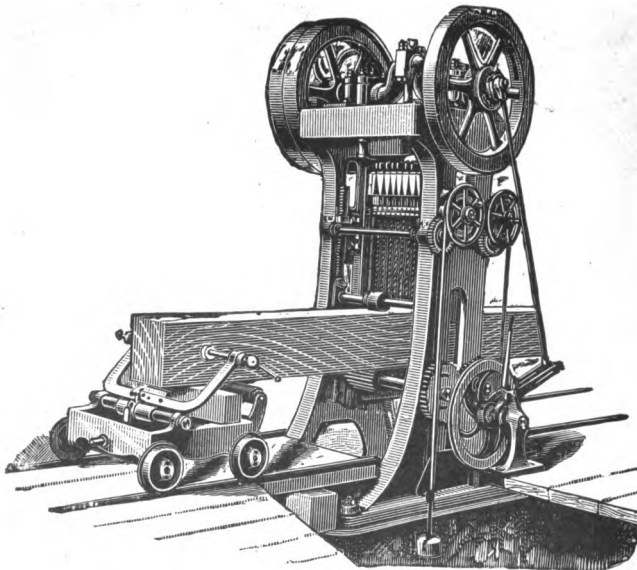

Fig. 3117.

**OVER-DRIVEN
TIMBER AND
DEAL FRAMES**
as Fig. 3117 fulfil all the conditions above referred to and are fixed at the level of the mill-house floor.

It will be seen that the machine is entirely self contained and specially adapted for use where foundations cannot conveniently be carried much below the level of the mill house floor.

The feed is by rack and pinion, or by roller gear as preferred, and the prices and weights are approximately the same as for the under-driven machines of similar proportions.

TIMBER AND DEAL FRAMES WITH ENGINES but otherwise similar in design to Fig. 3117, are made for use in situations where belt driving cannot conveniently be applied.

The feed is variable in speed and is arranged to work by roller or rack and pinion gear.

TIMBER AND DEAL FRAMES UNDER-DRIVEN OR OVER-DRIVEN—These machines (not illustrated) differ from Figs. 3116-7, in the details of construction, but fulfil similar conditions and, if provided with the deal cutting apparatus—the cost of which is given—the machine can be used alternately for converting timber or as a double deal frame.

The roller feed is variable in speed and the machine is complete with rails for a traverse of 30 feet, two timber carriages with clamps, fast and loose pulley, forked strap guide, screw keys, &c.

PRICES OF SAW FRAMES AS ABOVE.

Section of timber	24 in.	30 in.	36 in.
H.P. required	5	7	8
Price of log frame	£220	£242	£275
Price of log and deal frame	£250	£275	£310
Approximate weight	7	8½	10

The cost of packing for shipment and delivery f.o.b. is 5 per cent.

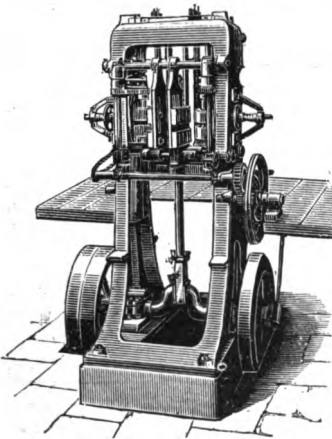

Fig. 3118.

DOUBLE DEAL FRAME WITH HORIZONTAL AND VERTICAL FEED ROLLERS, Fig. 3118.—The saw frame is of steel, carrying a large number of saws and the slides in which it reciprocates have large wearing surfaces and are adjustable.

The feed motion is obtained by a combination of horizontal and vertical rollers and is perfectly efficient, so that a large output of work is obtained, without any tendency to slipping in the feed.

The fences are mounted on slides adjustable by screw, which admits of the boards next the fence being varied in thickness, without altering the saws or stopping the frame.

The proportions and construction throughout are suited to high speed working, and the machines are complete with balanced flywheel, fast and loose pulley, strap guides, screw keys, &c.

PRICES OF DOUBLE DEAL FRAMES, Fig. 3118.

To cut two deals	14in. by 4in.	18in. by 6in.	24in. by 6in.
Price of machine as Fig. 3118	£140	£160	£170
„ „ if overhead driven	£160	£180	£190
„ saws and buckles	£0 12 0	£0 12 6	£0 14 0
H.P. required	3	3½	4
Approx. weight tons	4	5	6

The cost of packing for shipment and delivery f.o.b. is from 5 to 8 per cent.

UNDER-DRIVEN SINGLE DEAL FRAMES.—The principles of construction are similar to those adopted for the double frames, Fig. 3118, the proportions and arrangements being modified to those required for sawing one deal.

PRICES OF SINGLE DEAL FRAMES.

To cut one deal	14in. by 4in.	18in. by 6in.	24in. by 6in.
Price of machine	£80	£100	£110
H. P. required	2	2½	3
Approx. weight tons	2½	3	3½

The cost of packing for shipment and delivery f.o.b. is 5 per cent.

The prices of saws each are the same as for Fig. 3118.

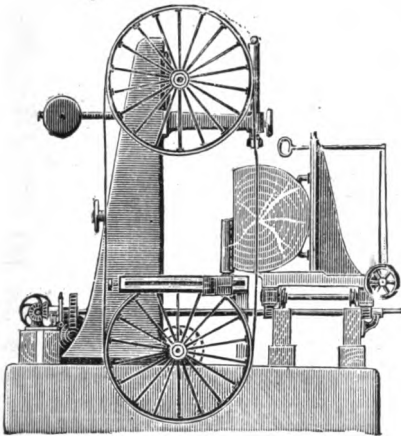

Fig. 3119.

BAND SAW WITH TRAVELLING TABLE.—The machine, Fig. 3119, is now largely used for opening out large logs through the middle, quartering them, sawing into flitches and boards and for similar work.

The saw pulleys are of wrought iron and of large diameter, and are provided with efficient automatic tension gears. These parts, as well as the gear which transmits motion to the travelling table, are carried on a strong standard of box section, with a wide base for bolting to the floor or foundations.

The travelling table, constructed of wrought iron, is usually about 24 feet long and is provided with all appliances for gripping the timber on the top and at the side and for setting the thickness of the board to be cut.

The feed motion can be varied to suit the work and has a quick return.

PRICES OF BAND SAWS WITH TRAVELLING BEDS, Fig. 3119.

Size of timber	30 in.	42 in.	48 in.
Price of machine	£250	£320	£400
Extra table per foot	£4	£4 10 0	£5
H. P. required	4	6	8
Approx. weight tons	7	9	10
Band saws, 3 in. each	£3 8 0	£4 8 0	£5 5 0

The cost of packing for shipment and delivery f.o.b. is from 5 to 8 per cent.

COLUMN OR WALL BAND SAWING MACHINES have adjustments to saw pulleys, table, &c. which fulfil (generally) the conditions last described, but they are adapted for bolting to a wall, column, or wood post. This reduces the cost and the weight of the machine but the principal object sought, in designing this tool, is to make it available for use where limited space does not admit of using a machine of the independent type, Fig. 3120.

PRICES OF COLUMN BAND SAWING MACHINES.

Diameter of saw pulleys	24 in.	30 in.	36 in.
Price of machine	£21	£27	£38

The cost of packing for shipment and delivery f.o.b. is 5 per cent.

BAND SAWS AS ABOVE BUT TO FIX TO TIMBER STANDARDS.—

The machinery suitable for opening, quartering or sawing logs, or converting them into boards, flitches, &c., is adapted for fixing to a timber or other standard provided by the purchaser in accordance with drawings supplied with the machinery.

The working parts comprise the top and bottom pulleys for carrying the saw, with spindles and bearings with long gun metal seatings, saw guides and tension appliances, also the rails, roller carriers and pedestals for a rack feed of table with variable speeds, for a traverse of 24 ft. gear for driving it, including striking levers for stopping or starting either the saw or the traversing motion, fast and loose pulleys, fork guides for strap, screw keys, &c.

The price of the machinery is £180 0 0

The power required is about 4 H.P.

The approximate weight is 4½ tons, and

The cost of packing for shipment and delivery f.o.b. is 8 per cent.

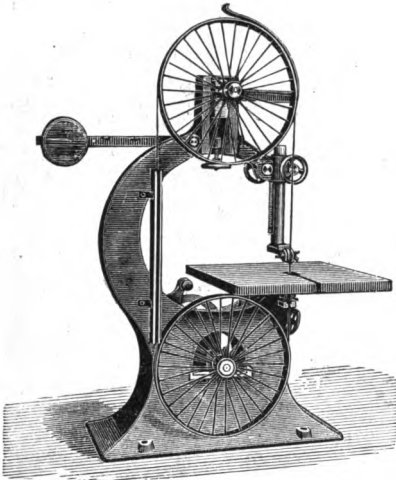

Fig. 3120.

The table is square and can be swivelled, and fixed, to cut at any angle required for bevil work.

BAND SAWING MACHINE WITH ADJUSTABLE TABLE.—Fig. 3120 represents the type of machine largely used in saw mills, workshops, &c. for general work, the proportions and the details of construction being modified to suit the dimensions of the machine and the conditions it has to fulfil.

The main frame is in one casting, of box section and carries the driving and the top and bottom saw pulleys. The latter are of the bicycle type, or are made of cast iron with curved arms, but in all cases, the rims are carefully balanced and covered with india rubber to form an elastic bed for the saw. The spindle for the top pulley is carried in long bearings of hard gun metal, adjustable in height, and the tension on the saw is automatically regulated by a spring connected with the top bearing, or by a lever with a movable weight, the position of which—for saws of different widths—is marked on the lever. Appliances are also provided for adjusting the saw to run on any part of the rubber covered rim, saw guides, guards for the protection of workmen, &c.

PRICES OF BAND SAWING MACHINES, Fig. 3120.

Diam. of saw pulleys	24 in.	30 in.	36 in.	42 in.	48 in.
Max. depth of cut	12 in.	16 in.	18 in.	18 in.	20 in.
H.P. required	½	1	2	2½	3
Price of machine	£25	£30	£45	£53	£65
Approx. weight cwt.	12	14	20	30	40

The cost of packing for shipment and delivery f.o.b. is 8 per cent.

FRET SAWS for light work.—The table is square and is supported on a cast iron pedestal, of box section, which carries the driving gear and the lever for instantly starting or stopping the saw.

The table is truly planed and can be adjusted and fixed to work at any angle. The saw is driven by a disc plate and connecting rod which works in planed guides attached to the upper end of the pedestal, the appliances for carrying the upper end of the saw being suspended from a beam over the saw table.

The price of the machine with pulleys, striking and suspension gear is £25 0 0

The approximate weight is 7½ cwt.

The cost of packing for shipment and delivery f.o.b. is 5 per cent.

PRICES OF SAWS AND OTHER ACCESSORIES required for renewals, &c. of saw mill plant, see the section relating to miscellaneous tools.

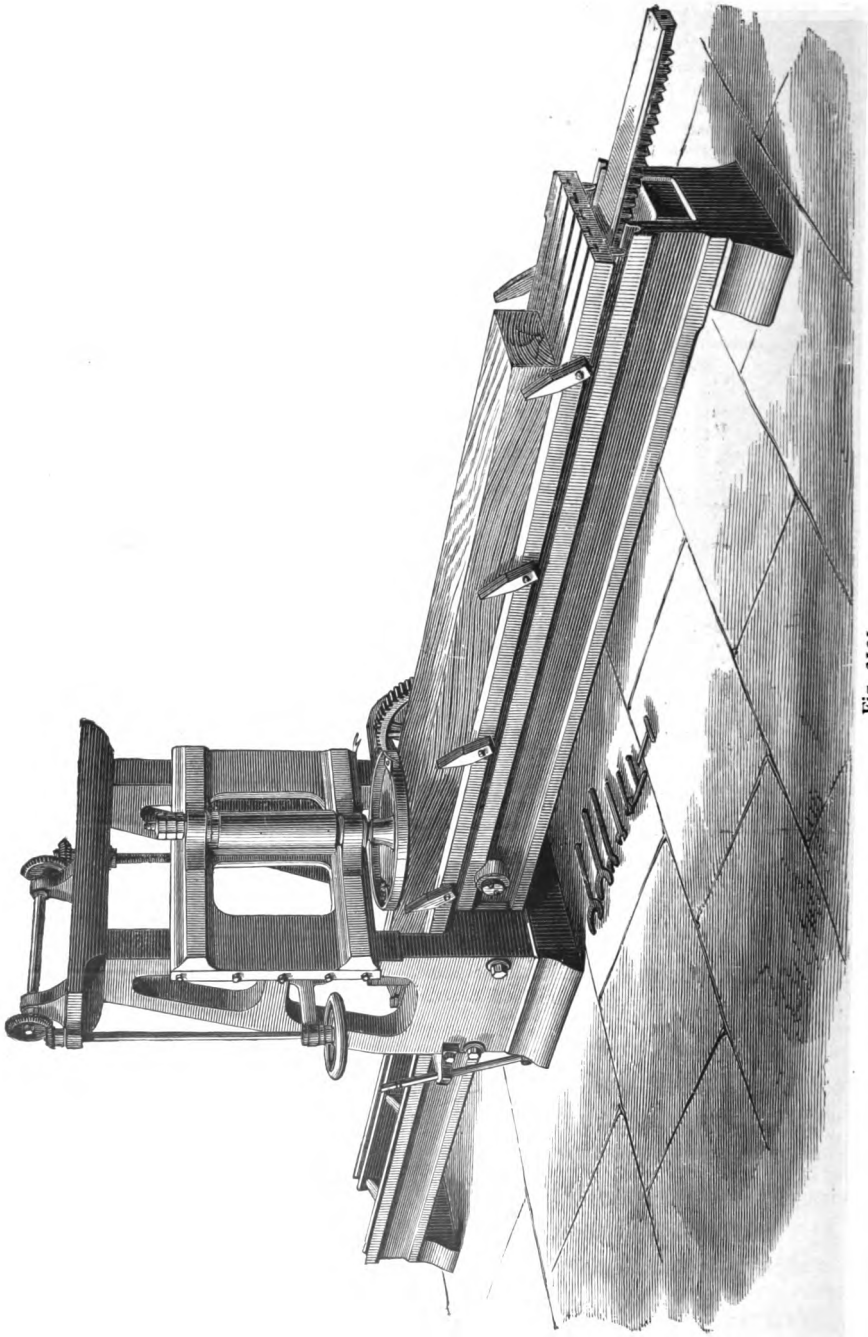

Fig. 3121.

PLANING AND SQUARING-UP MACHINE WITH REVOLVING DISC, Fig. 3121.—The timber, to be planed and made perfectly true for such work as railway carriage frames, doors, sashes, &c., is clamped to the planed cast iron travelling bed, this is traversed by rack and pinion gear, until it reaches a stop, adjusted to the length of the timber, which automatically reverses the direction of traverse.

The two larger size machines have double standards, as shown, and the smaller sizes, single standards, but in both cases the revolving cutter block disc is adjustable to suit the thickness to be planed.

The subjoined prices are for machines with a traverse of 15 feet, but the beds can be made any length at the extra cost per foot stated below. The machines are complete with counter-shaft, fast and loose pulley, belt guide, screw keys, etc.

PRICES OF PLANING AND SQUARING-UP MACHINES, Fig. 3121.

To plane in width up to	15 in.	18 in.	20 in.	24 in.
„ height	15 in.	15 in.	15 in.	15 in.
„ length	15 ft.	15 ft.	15 ft.	15 ft.
Price of machine	£150	£165	£180	£200
„ per foot of bed extra	£4	£4 10 0	£5	£6
H. P. required	2	2½	2½	3
Approximate weight tons	4	5½	6	6½

The cost of packing for shipment and delivery f.o.b. is from 5 to 8 per cent.

PLANING AND TRYING-UP MACHINES WITH HORIZONTAL CUTTER BLOCKS are similar in general construction to Fig. 3121, excepting that the cutter blocks are horizontal and are carried in a strong saddle, which spans the table and is raised or lowered in planed slides, to suit the thickness of the timber.

These machines plane any thickness up to 15 inches, and the prices are about 5 per cent. less than those given for Fig. 3121, the weights being approximately the same.

If with side cutter blocks to plane both edges and one side simultaneously, extra £40.

If with roller feed apparatus, which is easily put in and removed, extra £20.

The cost of packing for shipment and delivery f.o.b. is 5 per cent.

PLANING AND MOULDING MACHINES as Fig. 3122, to plane four sides

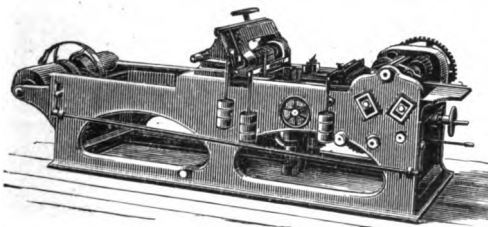

Fig. 3122.

at one operation or each side separately if desired, and to tongue, groove or stick straight mouldings, in hard or soft wood.

The timber is fed to the cutters by four fluted rollers with adjustments to suit the sections of timber. The side cutter blocks are easily removed for fixing other cutter heads, and the bottom cutter block is quite accessible.

If angular mouldings are required, the top cutter block can be arranged to work at an angle, and the extra cost of this for any of the machines is £5.

PRICES OF PLANING AND MOULDING MACHINES, Fig. 3122.

To plane in thickness up to	3 in.	4 in.	5 in.	6 in.
„ width	7 in.	12 in.	12 in.	16 in.
H. P. required	3	3½	4	6
Price of machine	£85	£120	£160	£180
Approximate weight tons	3	3½	5	5½

The cost of packing for shipment and delivery f.o.b. is from 5 to 8 per cent.

PLANING CUTTERS for above £0 1 0 per inch.

MOULDING CUTTERS £0 1 6 per inch.

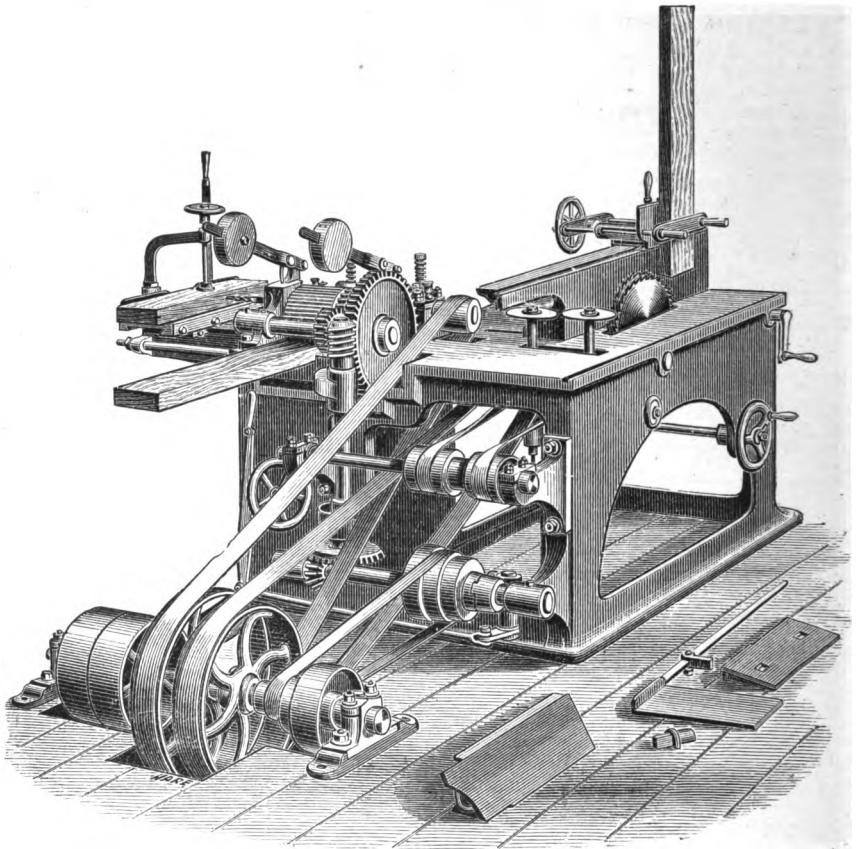

Fig. 3123.

THE GENERAL JOINER, Fig. 3123, as the title implies, performs most of the important work in joinery, cabinet and pattern making, including planing, squaring up scantling, straight or circular moulding, beading, chamfering, rebating, sawing, mitring, grooving, tonguing, tenoning, mortising, boring, &c., and renders excellent service where a number of machines cannot be conveniently, or profitably employed for these operations.

The planing cutter block works horizontally and is driven independently of the circular saw so that both may be used simultaneously. If desired the machine is arranged to work three sides at one operation. The feed is self-acting and adjustable, to plane, or cut mouldings of any section up to about 11 inches wide and 4 inches thick.

The saw spindle is provided with rising and falling motion and carries a saw of any diameter up to 20 inches, and cuts to a depth of 7 inches.

Tenons of any length up to 7 inches can be cut at one operation, by fixing two circular saws on the spindle, with a washer between them giving the width of the tenon required. The shoulders are cut by the two small circular saws in front of the large saw; the spindles which carry them have vertical and horizontal adjustments and take cutter blocks for circular moulding. These spindles are easily removed to leave the table clear for ordinary work.

The mortising and boring appliances are worked from the end of the cutter block spindle, which is bored up and arranged to receive the auger. The table to which the work is secured has a rising and falling motion, and stops to regulate the length of the mortise.

The machine is complete with countershaft, fast and loose pulley, belt guide, screw keys, &c.

The price of the machine is	£130 0 0
Extra for appliances to plane three sides at one operation	£30 0 0

About 4 nominal horse power is required to work the machine, the approximate weight is 2½ tons, and the cost of packing for shipment and delivery f.o.b. is from 5 to 8 per cent.

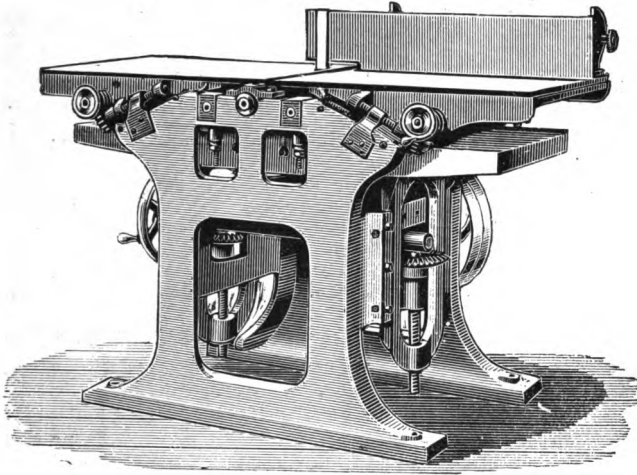

Fig. 3124.

POWER AND HAND FEED PLANING AND THICKENING MACHINES, illustrated by Fig. 3124, will plane timber out of wind, or to thickness, and can be used for either purpose without alteration.

The machine has two sets of tables one being below and the other above the cutter block, and both tables are adjustable in height. The timber to be thickened is carried on the first named table and is fed by rollers to pass under the cutters. These rollers, back and front of the cutter block, are

driven by gear and cone speed pulleys so that the speed of feed can be varied to suit different kinds of work.

The upper table is used for planing out of wind and the timber is fed by hand. The cutters are fixed at an angle which gives an efficient shearing action, and the top table is made in two sections, which are easily drawn apart, to give access to the cutter block.

Both sizes will plane any thickness up to 6 inches and are complete with countershaft, fast and loose pulley, strap guide, screw keys, &c.

PRICES OF PLANING AND THICKENING MACHINES, Fig. 3124.

To plane in width up to	18 in.	24 in.
Price of machine	£60	£70
H.P. required	2	2½
Approximate weight tons	1½	1½

The price of planing cutters is one shilling per inch in width.

The cost of packing for shipment and delivery f.o.b. is from 5 to 8 per cent.

PLANING AND THICKENING MACHINES for planing and thickening boards, panels, and scantlings, are made in the undernamed sizes.

The frame is similar in design to Fig. 3123 and the table is carried in vertical slides, adjustable in height by suitable screws, &c. The machine is complete with countershaft and cone speed pulley, main driving pulley, power driven feed apparatus, screw keys, &c.

PRICES OF PLANING MACHINES AS ABOVE.

To plane in width up to	12 in.	16 in.	18 in.	20 in.	24 in.
Price of machine	£45	£50	£55	£60	£70
H.P. required	1½	2	2	2	2½
Approximate weight.. .. . tons	1	1	1	1½	1½

The price of planing cutters is one shilling per inch in width.

The cost of packing for shipment and delivery f.o.b. is from 5 to 8 per cent.

HAND FEED PLANING MACHINES, Fig. 3125, are used for planing, surfacing, jointing, trying-up, rebating, and chamfering joinery or cabinet work.

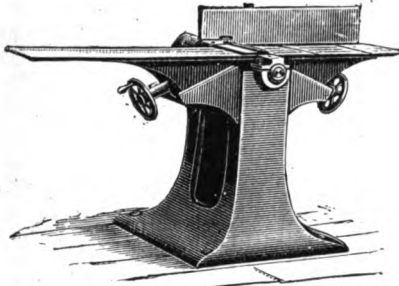

Fig. 3125.

The wood, of any section within the capacity of the machine, is passed over the cutters by hand and is turned out perfectly true and free from winding or twist.

The table is planed and is of the length required for truing up long stuff and preparing it for glued joints. The two tables can be raised or lowered, independently of each other, to suit the depth of cut required, without coming in contact with the cutters.

This motion, as well as a lateral motion to regulate the opening for the cutter block between the two halves of the table, is obtained by V grooved slides and adjustments by hand wheels, etc.

The fence is easily set up and firmly fixed in the vertical position shown, or at any desired angle.

The cutter block spindle is of steel and runs in long gun metal bearings with automatic lubricators.

Each machine is complete with countershaft, fast and loose pulley, strap guide, screw keys, &c.

PRICES OF HAND FEED PLANING MACHINES, Fig. 3125.

To plane in width	9 in.	12 in.	18 in.	24 in.	30 in.
Price of machine	£22	£25	£30	£35	£40
H.P. required	$\frac{3}{4}$	1	1½	1¾	2
Approximate weight	10	12½	15	18	21
	cwts.				

The cost of packing for shipment and delivery f.o.b. is 8 per cent.

UNIVERSAL WOOD WORKING MACHINES

of the type Fig. 3126, have all the mechanism required for planing, jointing, trying-up short lengths, stop chamfering, sawing, tonguing and grooving, tenoning, mortising and boring, and will turn out this wide range of cabinet and joinery work, uniform in quality and style, and—with this machine—one man or youth produces as much work as four skilled workmen using the ordinary tools.

The timber is fed by hand and the machine will plane and surface any width up to 12 ins.; the depth of cut is regulated by the appliances for adjusting the height of the front table.

For chamfering, the timber is guided against the fence which is fixed at the angle required, the tables being lowered to admit the cutters to project to cut the depth desired. For

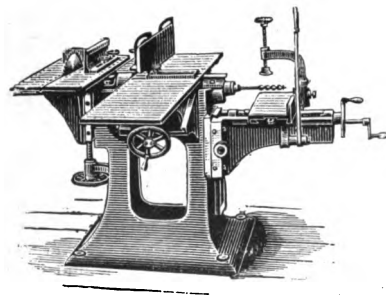

Fig. 3126.

stop chamfering, the fence is marked at the point where the chamfer is to be stopped.

The circular saw table is arranged to rise and fall, and the spindle carries the saw or the cutter block for tonguing and grooving. The front part of this table is made to slide, and is provided with a small fence, which can be set to any angle and used for cross cutting, mitre, or dimension sawing.

The saw spindle carries a cutter block for tenon cutting, the work being supported on a table with a fence which holds the timber in position.

The other end of the spindle is fitted with a cutter block spindle bored to receive an auger or slot mortise chisel, the work being secured to the table which has appliances for clamping and traversing, as shown.

The price of the machine, with countershaft, &c. for planing,

boring, mortising and sawing, is	£55	0	0
Ditto, to plane and mortise only	£40	0	0
Ditto, to plane and saw only	£40	0	0
Tenoning apparatus extra	£5	0	0

About 1 nominal horse power is required to drive the machine and the approximate weight is 22 cwts.

The cost of packing for shipment and delivery f.o.b. is from 5 to 8 per cent.

BOX NAILING MACHINES WORKED BY POWER will take in boxes up to 24 inches wide and drive any number of nails at one time; the nails are fed automatically and can be adjusted to the pitch required.

The price of the machine is £85.

The weight is about 1 ton and the cost of packing for shipment and delivery f.o.b. is 5 per cent.

SMALL BOX NAILING MACHINES, worked by treadle, drive three nails at one operation; the nails are fed automatically, the pitch is adjustable and one boy will nail 1000 boxes per day.

The price of machines to take in boxes of any size up to 11 in. deep and 13 in. long is £48. For machines to nail smaller boxes, the price is £35.

The cost of packing for shipment and delivery f.o.b. is 5 per cent.

BORING, OR BORING AND MORTISING MACHINES DRIVEN BY POWER fulfil the requirements of railway carriage and wagon builders, heavy joinery works, &c.

The boring and mortising tools are counterweighted and automatically return into position for another operation, so soon as the cut has been completed.

The boring tool, as is well known, frees the wood in the mortise and greatly increases the output of work.

The table, to which the timber is secured, has longitudinal, transverse and vertical adjustments, for rapidly bringing the work into position and the machine is complete with fast and loose pulley, strap guide, screw keys, etc.

PRICES OF POWER DRIVEN BORING AND MORTISING MACHINES.

To take in work	11 in. by 5 in.	12 in. by 8 in.
Width of mortise	2 in.	1 1/2 in.
H.P. required	3	1
Price of machine to mortise only	£45	£60
Do. do. to bore and mortise	£55	£70

The cost of packing for shipment and delivery f.o.b. is from 5 to 8 per cent.

HAND MORTISING, BORING AND TENNONING MACHINE, to take in work of any size up to 11 in. by 6 in.

The mortising and boring appliances are fixed to a vertical standard of box section and enlarged base. The table, which carries the work, is raised or lowered to the position required by a machine cut screw and hand wheel, and is traversed in V shaped slides for adjusting the work.

The boring apparatus is quite independent of that for mortising and can be worked by hand or driven by power.

The price of the machine to mortise only is	£20	0	0
Do. do. to mortise and bore	£23	10	0
Extra for tenoning tool	£1	5	0

The approximate weight is 10 cwt. and the cost of packing for shipment and delivery f.o.b. is 8 per cent.

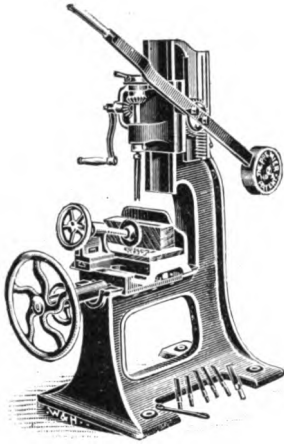

Fig. 3127.

The subjoined prices include an outfit of tools which includes six coring chisels, a core driver, screw keys, &c.

The price of the machine with traversing table 16 in. by 7 in. is £10 0 0
 Do. do. table 16 in. by 8 in. .. £13 0 0

The weights are respectively about 5 and 6½ cwt. and the cost of packing for shipment and delivery f.o.b. is 8 per cent.

HAND POWER MORTISING AND BORING MACHINE, Fig. 3127. It is estimated that one of these machines, worked by one man or boy, will produce as much work (and at least equal in quality) as can be done by six men using the ordinary tools.

The frame and base are in one casting and the number of working parts is reduced to a minimum.

The table to which the work is secured by a screw clamp, as shown, has planed V slides and is adjusted to commence or follow the cut, by the hand wheel and traversing gear indicated in the front of the engraving.

The saddle, which carries the mortising and boring gear, traverses in planed slides and is raised or lowered to suit the thickness of the timber.

The hand lever, for giving the feed to the mortising tool, works by rack and pinion which insures a steady motion and it is counter-weighted to give quick return.

The boring appliances are also attached to the mortising gear saddle and are worked by bevel multiplying gear and handle as shown.

These machines will mortise any depth up to 7 inches and are made in two sizes as indicated below.

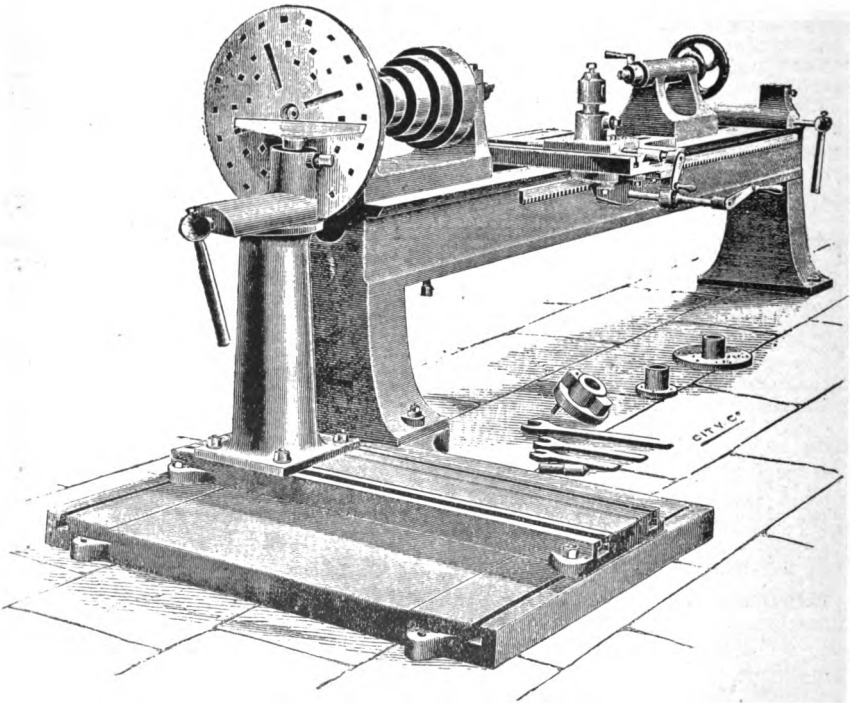

Fig. 3128.

WOOD TURNING LATHE for model makers (Fig. 3128) with face plate, adjustable pillar, and rest for turning and finishing large surfaces. The bed, supported on cast iron standards, is truly faced, and is usually straight, as shown, but it can be made with a gap if preferred. The fast headstock has the usual cone speeds, but is not double geared, and the spindle is extended at the back end to carry a large face outside the end of the bed. The base plate beneath and in front of the face plate has planed T slots for securing the column which carries an adjustable rest, and the extra cost of these very useful accessories will be found in the subjoined list.

The sliding carriage on the bed is traversed by rack and pinion gear, and the tool rest has a transverse sliding motion. Each tool is sent out complete with eccentric hand rest, overhead motion, fork centre, plain centre and screw keys.

PRICES OF WOOD MODEL MAKERS' LATHES, Fig. 3128.

Height of centres	6 in.	7 in.	8 in.	9 in.	10 in.	12 in.
Length of bed	6 ft.	7 ft.	8 ft.	10 ft.	12 ft.	12 ft.
Price of lathe as shown ..	£30	£33	£40	£47	£59	£74
Ditto, without end face plate, base, column, &c.	£24	£27	£33	£40	£51	£66
Extra length of bed per foot ..	£1 7	£1 10	£1 12	£1 15	£2	£2 5
Approximate weight .. cwt.s.	15	17	20	24	30	38

Packing for shipment and delivery f.o.b. is 5 per cent.

LATHE HEADS AND ACCESSORIES for wood or iron beds. The fixed headstock has a steel spindle carried in adjustable gun metal bearings, and is fitted with cone speed pulleys and face plate. If required the outer end of the spindle is extended for turning large diameters.

The movable headstock has a steel dead centre adjusted by screw and hand wheel and provided with a clamp nut, also a wing nut to hold it in position on the bed.

PRICES OF LATHE HEADS AND ACCESSORIES.

Height of centres	6 in.	8 in.	10 in.
Price of fixed head	£3 10 0	£5 10 0	£7 10 0
„ of movable head	£2 15 0	£4 0 0	£5 10 0
„ of T rest	£1 0 0	£1 7 6	£1 17 6
„ of overhead motion	£4 0 0	£4 15 0	£5 15 0

The cost of packing for shipment and delivery f.o.b. is 5 per cent.

TREADLE FRAMES, CRANKS AND CONNECTING RODS FOR LATHES.

Length of crank	3 ft.	4 ft.	5 ft.
Price for single crank	£1 10 0	£2 0 0	£2 10 0
„ double „	£2 5 0	£2 17 6	£3 2 6

CONED SPEED WHEELS FOR TREADLE AXLES, WITH TURNED GROOVES.

Diameter of wheel	20 in.	24 in.	27 in.	29 in.
Number of grooves	4	5	5	6
Price of wheel	£1 10 0	£1 15 0	£2 0 0	£2 7 6

Cost of packing &c., as above.

RADIAL BORING MACHINE DRIVEN BY BELT.—This machine is supported on a strong bracket which is fixed to a wall, column, or other attachment. The

radial arm is pivoted on a spindle in the bracket which carries the driving (fast and loose) pulley, and is provided with a swivelling arrangement which admits of boring, at any point, within a radius of about 3 ft. 6 in. The feed is by hand and the drill is counterweighted to give a quick return.

The price of the machine with fast and loose pulley is .. £16 0 0

The cost of packing for shipment and delivery f.o.b. is 8 per cent.

BRACKET BORING MACHINE to fix to a wall or column and driven by belt. The feed is by hand and the drill and spindle are counter-balanced. The machine will bore holes up to 2 in. diameter any depth up to 9 inches.

The price of the machine with fast and loose pulley is .. £8 10 0

The cost of packing for shipment and delivery f.o.b. is 8 per cent.

EMERY WHEEL SAW SHARPENING MACHINES for sharpening the teeth of circular or frame saws without filing.

A cast iron pedestal of box section carries the driving shaft and pulleys, the clamp vice for frame saws with vertical and transverse adjustments, as well as a balanced swing frame and emery disc which can be set to any angle.

The price of the machine is £27 0 0

Do. do. for mill webs only £24 0 0

The approximate weight is 15 cwt. and the cost of packing for shipment and delivery f.o.b. is 8 per cent.

Circular saw sharpening frame vice, price £3 10 0

Millsaw do. do. do. £3 5 0

Bandsaw do. do. do. £8 10 0

BANDSAW SHARPENING AND SETTING MACHINES, take in saws of different sizes and have appliances for maintaining the required tension whilst the teeth are being sharpened and set. For this purpose the saw is firmly held between two planed steel clamps and the teeth (of any size or pitch) are set uniformly by appliances worked by a hand wheel.

The price of the machine complete is £22 10 0

The weight is about 8 cwt. and the cost of packing for shipment and delivery f.o.b. is 8 per cent.

BANDSAW BRAZING FURNACE for brazing large saws. The hearth with clay lining is mounted on iron standards and is complete with hood, rotary fan and support for carrying the saw when being welded.

The price of the furnace as above is £27 0 0

The weight is about 5 cwt. and the cost of packing for shipment and delivery f.o.b. is 8 per cent.

FURNACE FOR BRAZING SMALL BANDSAWS with hearth fixed on a wrought iron cylindrical case which contains a circular double blast bellows, lever for working them, &c.

The price of the furnace is £6 10 0

The weight is about 3 cwt. and the cost of packing for shipment and delivery f.o.b. is 8 per cent.

HAND TOOLS & ACCESSORIES.

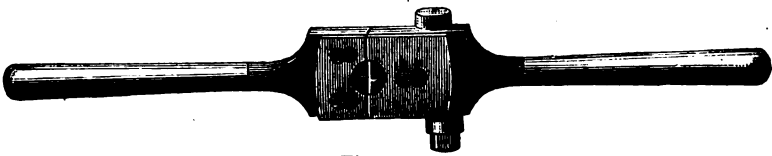

Fig. 3129.

WHITWORTH PATTERN GUIDE STOCKS AND DIES.

TO SCREW AND TAP	With Taper & Plug Tap to each size.	With Taper, Second, & Plug Tap to each size.	With Taper, Second, Plug and Master Tap to each size.	TO SCREW AND TAP	With Taper & Plug Tap to each size.	With Taper, Second, & Plug Tap to each size.	With Taper, Second, Plug and Master Tap to each size.
	£ s. d.	£ s. d.	£ s. d.		£ s. d.	£ s. d.	£ s. d.
1/8	3 6 0	3 10 0	3 16 0	7/8	6 0 0	7 1 0	8 5 0
1/4	3 15 0	3 2 0	3 10 0	1 1/8	7 2 6	8 7 6	9 18 0
3/8	3 4 0	3 12 6	4 2 0	1 1/4	8 3 6	9 18 0	11 8 0
1/2	3 9 0	4 2 0	4 14 0	1 3/8	6 5 0	7 5 6	8 10 0
5/8	3 0 0	3 7 6	3 16 0	1 1/2	6 7 0	7 8 0	8 12 0
3/4	3 1 6	3 10 0	4 0 0	1 5/8	6 10 0	7 18 6	9 1 0
7/8	3 10 0	4 0 0	4 11 0	1 3/4	7 10 0	8 16 0	10 7 0
1	3 11 0	4 1 6	4 14 0	1 7/8	7 15 6	9 4 6	10 19 0
1 1/8	4 1 0	4 18 6	5 8 0	2	9 0 0	10 18 6	12 14 0
1 1/4	3 10 0	4 0 0	4 11 0	2 1/8	8 19 0	10 18 0	12 14 0
1 1/2	4 1 0	4 18 0	5 7 0	2 1/4	7 10 0	8 17 0	10 9 0
1 3/4	4 2 6	4 15 0	5 10 0	2 3/8	7 17 0	9 8 0	11 5 0
1 7/8	4 5 0	4 19 0	5 15 0	2 1/2	9 2 0	10 17 0	12 19 0
2	4 12 0	5 6 0	6 2 0	2 5/8	9 10 0	11 9 0	13 15 0
2 1/8	5 4 0	6 1 0	7 1 0	3	11 1 0	13 6 0	16 0 0
2 1/4	4 0 0	4 12 6	5 7 0	3 1/8	11 0 0	12 16 0	14 19 0
2 1/2	4 12 6	5 8 6	6 6 0	3 1/4	11 10 0	13 11 0	16 0 0
2 3/4	4 19 0	5 16 0	6 17 0	3 3/8	12 18 0	14 16 0	17 7 0
3	5 7 0	6 4 6	7 5 0	3 1/2	13 10 0	16 2 0	19 4 0
3 1/8	4 10 0	5 5 0	6 8 0	3 5/8	15 7 0	18 7 0	21 19 0
3 1/4	5 6 0	6 4 0	7 5 0	4	11 18 0	13 14 0	16 4 0
3 1/2	5 11 0	6 12 0	7 17 0	4 1/8	12 7 0	14 15 0	17 18 0
3 3/4	6 1 0	7 1 0	8 5 0	4 1/4	13 0 0	15 15 0	19 1 0
4	4 17 0	5 13 0	6 12 0	4 3/8	14 7 0	17 4 0	20 12 0
4 1/8	5 0 0	5 17 6	6 18 0	4 1/2	15 10 0	18 19 0	21 1 0
4 1/4	5 14 0	6 18 0	7 15 0	4 5/8	17 15 0	21 15 0	26 11 0
4 1/2	5 19 6	7 1 0	8 0 0	5	19 5 0	22 19 0	26 10 0
4 3/4	6 17 0	8 2 0	9 11 0	5 1/8	20 10 0	23 4 0	33 15 0
				5 1/4	23 5 0	27 10 0	32 11 0
				5 1/2	28 9 0	34 5 0	41 9 0

WHITWORTH PATTERN STOCKS AND DIES, fitted in oak or deal case.
 Guide stock illustrated Fig. 3129, and case as Fig. 3130.

TO SCREW AND TAP BOLTS AND NUTS.		With Taper and Plug Tap to each size, and Tap Wrenches.		With Taper, 2nd, and Plug Tap to each size, and Tap Wrenches.		With Taper, 2nd, Plug and Master Tap to each size, and Tap Wrenches.	
		Deal Case	Oak Case.	Deal Case	Oak Case	Deal Case	Oak Case
No.	To Screw.	£ s. d.	£ s. d.	£ s. d.	£ s. d.	£ s. d.	£ s. d.
1 set	7 1.	11 8 0	11 18 0	12 12 0	18 2 0	14 5 0	14 15 0
2 "	7 1. 1	11 10 0	12 0 0	18 0 0	18 10 0	14 17 0	15 7 0
3 "	7 1. 1 1	12 18 0	18 8 0	14 18 0	15 3 0	16 15 0	17 5 0
4 "	7 1. 1 1 1	16 8 0	17 0 0	18 9 0	19 6 0	21 4 0	22 1 0
5 "	7 1. 1 1 1 1	16 12 0	17 9 0	18 19 0	19 16 0	21 17 0	22 14 0
6 "	7 1. 1 1 1 1 1	19 5 0	20 2 0	21 18 0	22 15 0	25 2 0	25 19 0
7 "	7 1. 1 1 1 1 1 1	28 6 6	34 4 0	36 18 0	37 16 0	41 1 0	41 19 0
8 "	7 1. 1 1 1 1 1 1 1	28 12 0	24 10 0	27 6 0	28 4 0	31 12 0	32 11 0
9 "	7 1. 1 1 1 1 1 1 1 1	25 1 0	25 19 0	29 0 0	29 18 0	33 12 0	34 10 0
10 "	7 1. 1 1 1 1 1 1 1 1 2	86 2 0	87 15 0	41 15 0	43 8 0	48 13 0	50 5 0
11 "	7 1. 1 1 1 1 1 1 1 1 1 2	44 7 0	46 0 0	61 17 0	63 10 0	60 14 0	62 7 0
12 "	7 1. 1 1 1 1 1 1 1 1 1 1 2	45 15 0	47 8 0	63 11 0	65 4 0	63 18 0	64 6 0

The above are all fitted into one case, except the three largest sizes, which are fitted into two cases.

ENGINEERS' STOCKS AND DIES, WHITWORTH STANDARD THREADS as shewn, fitted in case Fig. 3130.

TO SCREW AND TAP.	With Taper, Second, and Plug and Master Tap to each size.			TO SCREW AND TAP.	With Taper, Second, and Plug and Master Tap to each size.		
	£ s. d.	£ s. d.	£ s. d.		£ s. d.	£ s. d.	£ s. d.
1 1. 1	1 0 0	1 4 0	1 9 0	1 1. 1	3 4 0	4 2 0	5 8 0
1 1. 1 1	1 5 0	1 10 0	1 17 0	1 1. 1 1	3 16 0	4 18 0	6 5 0
1 1. 1 1 1	1 10 0	1 17 0	2 5 0	1 1. 1 1 1	4 8 0	5 14 0	7 4 0
1 1. 1 1 1 1	1 17 0	2 5 0	3 15 0	1 1. 1 1 1 1	5 4 0	6 2 0	8 8 0
1 1. 1 1 1 1 1	1 9 0	1 15 0	2 3 0	1 1. 1 1 1 1 1	3 6 0	4 4 0	5 5 0
1 1. 1 1 1 1 1 1	1 10 0	1 17 0	2 5 0	1 1. 1 1 1 1 1 1	3 6 0	4 6 0	5 10 0
1 1. 1 1 1 1 1 1 1	1 17 0	2 5 0	3 15 0	1 1. 1 1 1 1 1 1 1	3 17 0	5 0 0	6 7 0
1 1. 1 1 1 1 1 1 1 1	1 18 6	2 7 0	3 18 0	1 1. 1 1 1 1 1 1 1 1	3 19 0	5 4 0	6 14 0
1 1. 1 1 1 1 1 1 1 1 1	2 6 0	3 15 0	3 9 0	1 1. 1 1 1 1 1 1 1 1 1	4 12 6	6 2 0	7 18 0
1 1. 1 1 1 1 1 1 1 1 1 1	1 12 6	2 1 0	3 11 0	1 1. 1 1 1 1 1 1 1 1 1 1	5 0 0	6 9 0	8 4 0
1 1. 1 1 1 1 1 1 1 1 1 1 1	1 19 0	2 9 0	3 1 0	1 1. 1 1 1 1 1 1 1 1 1 1 1	4 8 0	5 11 0	6 19 0
1 1. 1 1 1 1 1 1 1 1 1 1 1 1	2 0 0	3 10 0	3 8 0	1 1. 1 1 1 1 1 1 1 1 1 1 1 1	4 14 0	6 1 0	7 13 0
1 1. 1 1 1 1 1 1 1 1 1 1 1 1 1	2 3 0	3 14 0	3 9 0	1 1. 1 1 1 1 1 1 1 1 1 1 1 1 1	5 6 0	6 16 0	8 12 0
1 1. 1 1 1 1 1 1 1 1 1 1 1 1 1 1	2 8 0	3 19 0	3 14 0	1 1. 1 1 1 1 1 1 1 1 1 1 1 1 1 1	5 18 0	7 6 0	9 6 0
1 1. 1 1 1 1 1 1 1 1 1 1 1 1 1 1 1	2 15 0	3 10 0	4 7 0	1 1. 1 1 1 1 1 1 1 1 1 1 1 1 1 1 1	6 12 0	8 11 0	10 18 0
1 1. 1 1 1 1 1 1 1 1 1 1 1 1 1 1 1 1	3 0 0	3 10 0	3 8 0	1 1. 1 1 1 1 1 1 1 1 1 1 1 1 1 1 1 1	6 10 0	8 4 0	10 1 0
1 1. 1 1 1 1 1 1 1 1 1 1 1 1 1 1 1 1 1	2 8 0	3 0 0	3 15 0	1 1. 1 1 1 1 1 1 1 1 1 1 1 1 1 1 1 1 1	6 19 0	9 18 0	11 1 0
1 1. 1 1 1 1 1 1 1 1 1 1 1 1 1 1 1 1 1 1	2 15 0	3 11 0	4 9 0	1 1. 1 1 1 1 1 1 1 1 1 1 1 1 1 1 1 1 1 1	7 16 0	9 16 0	12 0 0
1 1. 1 1 1 1 1 1 1 1 1 1 1 1 1 1 1 1 1 1 1	2 7 0	3 0 0	3 15 0	1 1. 1 1 1 1 1 1 1 1 1 1 1 1 1 1 1 1 1 1 1	8 8 0	10 12 0	13 5 0
1 1. 1	2 15 0	3 11 0	4 10 0	1 1. 1	9 6 0	12 8 0	15 5 0
1 1. 1	3 7 0	4 4 0	5 5 0	1 1. 1	8 0 0	9 19 0	12 2 0
1 1. 1	2 15 0	3 9 0	4 6 0	1 1. 1	8 10 0	10 16 0	13 6 0
1 1. 1	2 18 0	3 11 0	4 9 0	1 1. 1	9 8 0	11 15 0	14 12 0
1 1. 1	3 7 0	4 3 0	5 2 0	1 1. 1	10 4 0	12 18 0	15 17 0
1 1. 1	3 11 0	4 5 0	5 8 0	1 1. 1	10 10 0	13 15 0	17 6 0
1 1. 1	3 17 0	4 18 0	6 8 0	1 1. 1	11 10 0	15 6 0	19 9 0

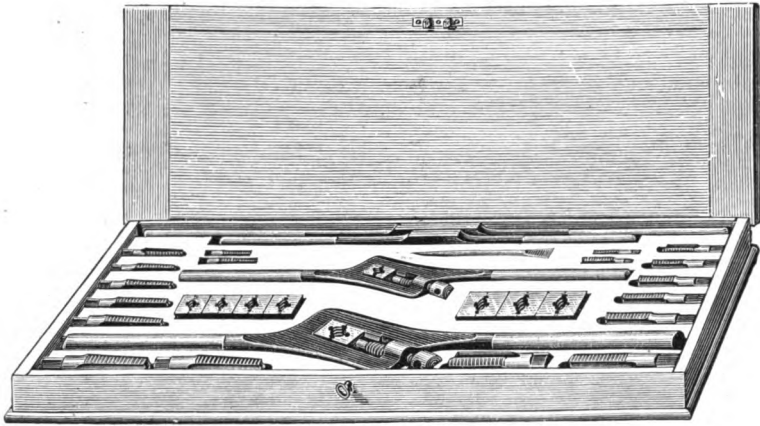

Fig. 3130.

ENGINEERS' STOCKS AND DIES, WHITWORTH STANDARD THREADS, fitted in oak or deal cases, Fig. 3130.

TO SCREW AND TAP BOLTS AND NUTS.		With Taper and Plug Tap to each size, and Tap Wrenches.		With Taper, 2nd, and Plug, Tap to each size, and Tap Wrenches.		With Taper, 2nd, Plug and Master Tap to each size, and Tap Wrenches.	
		Deal Case	Oak Case	Deal Case	Oak Case	Deal Case	Oak Case
No.	To Screw.	£ s. d.	£ s. d.	£ s. d.	£ s. d.	£ s. d.	£ s. d.
1 set	1... ..	6 14 0	7 3 0	7 18 0	8 8 0	9 6 0	9 17 0
2 "	1 1/8 1/2 ...	6 19 0	7 8 0	8 4 0	8 14 0	9 15 0	10 6 0
3 "	1 1/4 3/8 1/2 ...	8 2 0	8 11 0	9 11 0	10 1 0	11 8 0	11 19 0
4 "	1 1/2 1/2 1 1/2 ...	9 15 0	10 6 0	11 11 0	12 5 0	13 18 0	14 18 0
5 "	1 3/4 1 1/2 1 1/2 ...	9 14 0	10 7 0	11 15 0	12 9 0	14 4 0	14 19 0
6 "	2 1/4 1 3/4 1 1/2 1 1/2 ...	11 8 0	12 1 0	13 13 0	14 6 0	15 7 0	17 2 0
7 "	2 1/2 1 3/4 1 1/2 1 1/2 ...	14 12 0	15 8 0	17 14 0	18 11 0	21 6 0	22 4 0
8 "	2 3/4 1 3/4 1 1/2 1 1/2 ...	14 17 0	15 18 0	17 19 0	18 16 0	21 13 0	22 11 0
9 "	3 1/4 1 3/4 1 1/2 1 1/2 ...	16 1 0	16 17 0	19 7 0	20 4 0	23 7 0	24 5 0
10 "	3 1/2 1 3/4 1 1/2 1 1/2 ...	24 2 0	25 14 0	29 4 0	30 18 0	34 19 0	36 15 0
11 "	3 3/4 1 3/4 1 1/2 1 1/2 ...	29 18 0	31 6 0	36 10 0	38 0 0	44 2 0	45 14 0
12 "	4 1/4 1 3/4 1 1/2 1 1/2 ...	31 2 0	32 10 0	37 18 0	39 8 0	45 15 0	47 7 0

The above are all fitted into one case, excepting the three largest sizes, which are fitted into two cases.



Fig. 3131.

STOCKS AND DIES FOR COPPER OR BRASS PIPES, with taper and plug taps, Fig. 3131.

To screw and tap ...	3/8 1/8	1 1/8 1/8	3/4 1/8	1 1/4 1/8	3/4 1/8	1 1/2 1/8	5/8 1/8	3/4 1/8	5/8 1/8
Price per set ...	25/6	25/6	25/6	29/-	33/-	37/-	44/-	50/-	60/-

NOTE.—The smallest size will also screw 1/4 in. iron tube.

PRICES OF PATENT TWIST DRILLS, WITH TAPER SHANK AND GRINDING LINE, Fig. 3132.

Diam.				Length				Price each				No. of Socket into which Shank of Drill fits, and price of Socket.			
Inches		Inches		£	s.	d.		Inches		Inches		£	s.	d.	
1/4	6 1/8	0	2	0	1	1	Price of No. 1 Socket, 5/-	1 1/4	11 1/4	0	12	9	3	Price of No. 3 Socket, 8/6	
1/2	6 1/2	0	2	1	1	1 1/2		11 1/4	0	13	4	3			
3/4	6 3/4	0	2	2	1	1 3/4		11 1/4	0	14	0	3			
1	6 7/8	0	2	3	1	1 7/8		12	0	14	9	3	Price of No. 4 Socket, 14/3		
1 1/8	6 7/8	0	2	5	1	1 7/8		12	0	15	6	3			
1 1/4	7	0	2	7	1	1 3/4		12 1/2	0	16	4	3			
1 1/2	7 1/4	0	2	10	1	1 5/8		14 1/2	0	18	0	4	Price of No. 5 Socket, 40/-		
1 3/4	7 3/4	0	3	1	1	1 3/4		14 1/2	0	19	0	4			
1 7/8	7 3/4	0	3	4	1	1 7/8		14 1/2	1	1	6	4			
2	8	0	3	8	1	1 7/8		15	1	4	0	4	Price of No. 4 Socket, 14/3		
2 1/8	8 1/4	0	4	0	1	1 5/8	15 1/2	1	11	6	4				
2 1/4	8 1/2	0	4	4	1	1 5/8	15 1/2	1	12	6	4				
2 3/8	8 3/4	0	4	9	2	1 5/8	15 1/2	1	13	8	4	Price of No. 5 Socket, 40/-			
2 1/2	9	0	5	2	2	1 5/8	16	1	15	6	4				
2 5/8	9 1/4	0	5	7	2	1 5/8	16 1/2	1	18	0	4				
2 3/4	9 1/2	0	6	1	2	1 5/8	16 1/2	2	0	0	4	Price of No. 4 Socket, 14/3			
2 7/8	9 3/4	0	6	7	2	1 5/8	16 1/2	2	1	8	4				
3	10	0	7	1	2	1 5/8	16 1/2	2	1	8	4				
3 1/8	10 1/4	0	7	7	2	2	16 1/2	2	3	0	4	Price of No. 5 Socket, 40/-			
3 1/4	10 1/2	0	8	1	2	2 1/8	17 1/2	2	12	0	5				
3 1/2	10 3/4	0	8	8	2	2 1/8	17 1/2	2	18	0	5				
3 3/4	10 7/8	0	9	10	3	2 1/8	19	3	5	0	5	Price of No. 4 Socket, 14/3			
3 7/8	10 3/4	0	9	3	3	2 1/8	19	3	13	0	5				
4	11	0	10	5	3	2 1/8	20 1/2	4	0	0	5				
4 1/8	11 1/4	0	11	0	3	2 1/8	20 1/2	4	5	0	5	Price of No. 5 Socket, 40/-			
4 1/4	11 1/2	0	11	7	3	2 1/8	20 1/2	4	5	0	5				
4 1/2	11 3/4	0	12	2	3	3	22	4	10	0	5				

TWIST DRILLS AS ABOVE, IN METRICAL DIMENSIONS.

Millimetres				Price each				No. of Socket into which Shank of Drill fits, and price of Socket.			
£	s.	d.		Millimetres		£	s.	d.			
0	2	0	1	33	0	18	0	4	Price of No. 4 Socket, 14/3		
0	2	1	1	34	0	18	6	4			
0	2	2	1	35	0	19	0	4			
0	2	4	1	36	1	0	0	4	Price of No. 5 Socket, 40/-		
0	2	7	1	37	1	1	9	4			
0	2	10	1	38	1	4	0	4			
0	3	2	1	39	1	11	0	4	Price of No. 4 Socket, 14/3		
0	3	6	1	40	1	12	6	4			
0	3	11	1	41	1	13	6	4			
0	4	4	1	42	1	14	6	4	Price of No. 5 Socket, 40/-		
0	4	10	2	43	1	15	8	4			
0	5	4	2	44	1	16	8	4			
0	5	11	2	45	1	17	9	4	Price of No. 4 Socket, 14/3		
0	6	6	2	46	1	18	9	4			
0	7	1	2	47	2	0	0	4			
0	7	9	2	48	2	1	3	4	Price of No. 5 Socket, 40/-		
0	8	5	2	49	2	2	3	4			
0	9	2	2	50	2	3	0	4			
0	9	11	3	54	2	7	0	5	Price of No. 4 Socket, 14/3		
0	10	8	3	57	2	12	0	5			
0	11	5	3	60	2	18	0	5			
0	12	2	3	64	3	5	0	5	Price of No. 5 Socket, 40/-		
0	12	11	3	67	3	13	0	5			
0	13	9	3	70	4	0	0	5			
0	14	7	3	73	4	5	0	5	Price of No. 4 Socket, 14/3		
0	15	5	3	76	4	10	0	5			
0	16	3	3								

PATENT TWIST DRILLS, with taper shank and grinding line turned to Whitworth standard gauges, Fig. 3132.



Fig. 3132.

THE SHANKS OF THESE DRILLS ARE THE SAME SIZE AS THE "AMERICAN" DRILL and attention is directed to the sockets made for these drills, by using which all further fitting of the drills to the machine is saved.

PATENT TWIST DRILLS with straight shanks.



Fig. 3133.

PRICES OF PATENT TWIST DRILLS WITH STRAIGHT SHANK, Fig. 3133.

Diameter..	..	$\frac{1}{8}$	$\frac{3}{16}$	$\frac{1}{4}$	$\frac{5}{16}$	$\frac{3}{8}$	$\frac{7}{16}$	$\frac{1}{2}$	$\frac{9}{16}$	$\frac{5}{8}$	$\frac{11}{16}$	$\frac{3}{4}$	$\frac{7}{8}$	1	$1\frac{1}{8}$	inch.
Length	$2\frac{1}{2}$	$3\frac{1}{8}$	$3\frac{3}{4}$	4	$4\frac{1}{2}$	$4\frac{3}{4}$	$4\frac{1}{2}$	5	$5\frac{1}{2}$	$5\frac{3}{4}$	6	$6\frac{1}{8}$	8	8	"
Price each	..	6d.	7d.	8d.	10d.	1/2	1/3	1/4	1/7	1/11	2/1	2/3	2/5	2/8	3/4	"
Diameter	$\frac{9}{16}$	$1\frac{1}{8}$	$1\frac{1}{4}$	$1\frac{1}{2}$	$1\frac{3}{8}$	$1\frac{5}{8}$	$1\frac{3}{4}$	$1\frac{7}{8}$	$1\frac{1}{2}$	$1\frac{5}{8}$	$1\frac{3}{4}$	$1\frac{7}{8}$	$1\frac{1}{2}$	$1\frac{3}{4}$	inch.
Length	$8\frac{1}{2}$	$8\frac{1}{2}$	$8\frac{1}{2}$	9	$9\frac{1}{2}$	$9\frac{1}{2}$	$9\frac{1}{2}$	10	10	$10\frac{1}{2}$	$10\frac{1}{2}$	$10\frac{1}{2}$	$10\frac{1}{2}$	11	"
Price each	..	3/9	4/2	4/8	5/1	5/6	5/11	6/4	7/1	7/7	8/1	8/8	9/3	9/10	10/5	11/-

Cast steel of special quality	60/-	per cwt.
Best cast steel, all sections for Engineers' tools	48/-	"
Octagon cast steel for Miners' tools	36/-	"
Spring steel	24/-	"
Double shear steel	48/-	"
Steel sheets	10/6	"
Steel Forgings	20/-	"

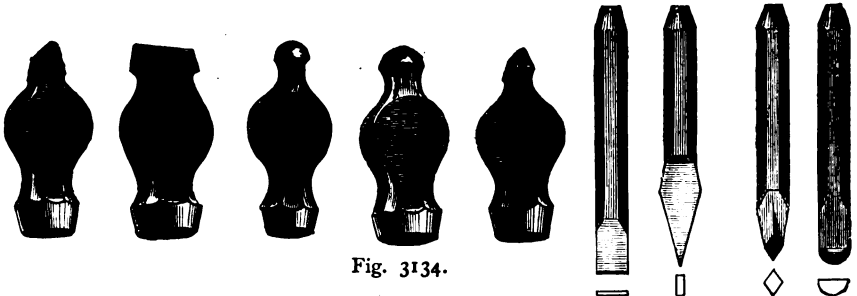

Fig. 3134.

CAST STEEL HAND HAMMERS AND CHISELS as generally used by Engineers are illustrated above, Fig. 3134, and are made of best cast steel, and well finished.

PRICES OF ENGINEERS' HAMMERS AND CHISELS, Fig. 3134.

Weight of hammers, ozs.	..	8	10	12	14	16
Price of do. per doz.	12/-	12/9	13/6	14/3	15/-
Do. do. over 1 1/2 lbs. is 1/- per lb.	..					
Do. chisels, flat, cross cut, diamond or half round is 1/- per lb.	..					

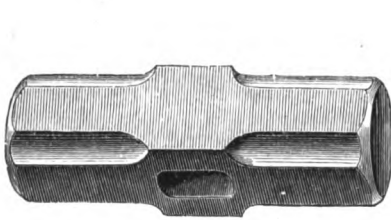
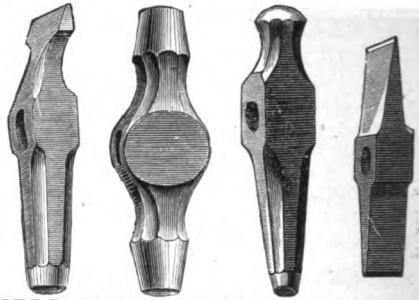

Fig. 3135.



CAST STEEL SLEDGE HAMMERS AND BOILER MAKERS' HAMMERS, Fig. 3135, are made in various shapes for special purposes, but those now illustrated are found most generally useful; the shape does not affect the price, which is 1/- per lb. for all ordinary patterns.

The price of boiler scaling hammers of the type illustrated to the right of Fig. 3135 is 12/- per doz.

PRICES OF HAMMER HANDLES.

Length of handles, inches ..	12	14	16	18	20	22	24	27	30	33	36
Price of ash do. per doz.	2/-	2/2	2/5	2/9	3/6	3/9	4/3	4/9	5/-	5/6	6/-
Do. hickory do. do.	2/4	2/6	2/10	3/6	3/11	4/3	4/6	5/6	6/3	6/9	7/-

Packed in cases of six or twelve dozen.

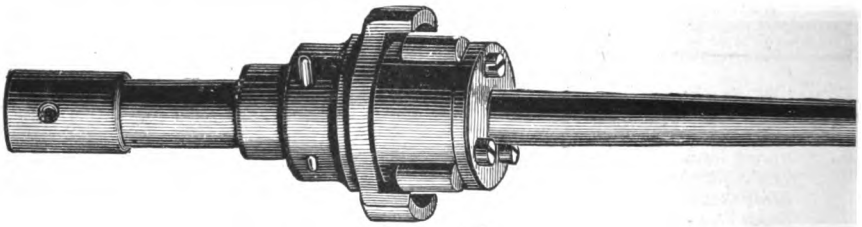

Fig. 3136 A

TUBE EXPANDERS.—The use and advantages of these handy tools, for expanding the ends of tubes are too well known to need special explanation. Those referred to below are of the latest design, are made of the best material, and all the parts are well-hardened; the dimensions given refer to the external diameter of the tubes.

PRICES OF TUBE EXPANDERS, Fig. 3136 A.

Size ins. ..	1	1½	1¾	1¾	1¾	1¾	1¾	2	2½	2½	2½
Price ..	30/-	30/-	30/-	30/-	32/6	36/3	36/3	42/-	45/-	50/-	60/-
Size ins. ..	2¾	2¾	3	3½	3½	3½	4	4½	4½	5	6
Price ..	65/-	70/-	80/-	87/6	100/-	110/-	120/-	130/-	140/-	175/-	185/-

The cost of packing for shipment and delivery f.o.b. is 6 per cent.

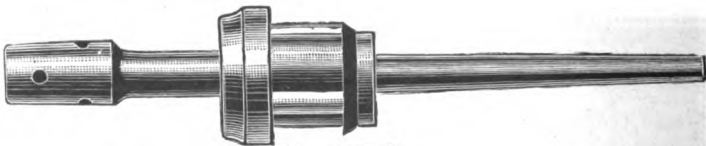

Fig. 3136 B.

THE TUBE EXPANDERS illustrated Fig. 3136 B, are provided with a ready method of changing the rolls, and although less expensive than those above referred to, the mandrils and rolls are made of the same high quality of steel.

PRICES OF TUBE EXPANDERS, Fig. 3136 B.

Size, ins.	1	1 1/4	1 3/8	1 1/2	1 5/8	1 3/4	1 7/8	2	2 1/8	2 1/4	2 1/2	2 3/4	3	3 1/4	3 1/2	3 3/4	4
Price	12/-	12/-	12/-	12/-	14/6	14/6	15/6	17/-	19/-	20/-	21/6	23/6	27/-	29/6	33/6	36/-	40/-

The cost of packing for shipment and delivery f.o.b. is 6 per cent.

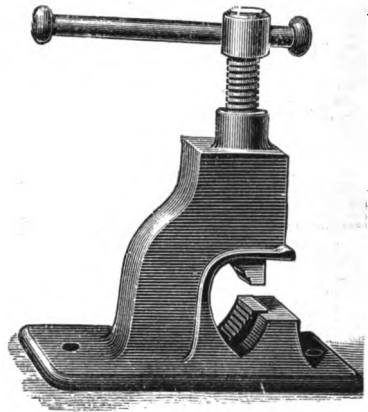
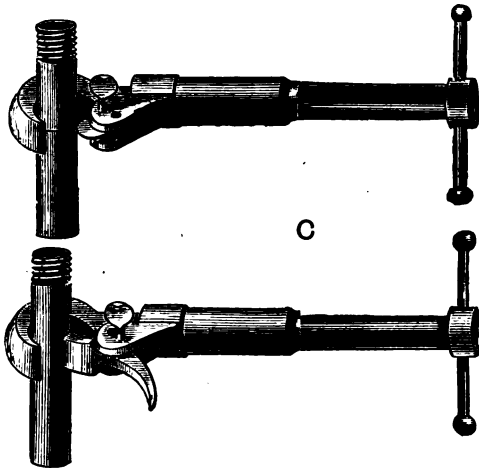

D Fig. 3136. E

TUBE CUTTER AND WRENCH COMBINED.—Fig. 3136 C shows the tool as used when cutting a pipe, and D with the gripping block inserted in the place of the cutting tool, for tightening up a joint and thus dispense with the use of two tools. The jaws are of hardened steel, and the parts giving the adjustment for pipes of different diameters are enclosed.

PRICES OF TUBE CUTTERS AND WRENCHES, Fig. 3136 C and D.

For tubes external diameter	1/2 in. to 1 in.	1 1/2 in. to 2 in.	2 1/2 in. to 3 1/2 in.
Price of tool	£0 16 0	£1 6 0	£1 16 6
Extra cutters, each	£0 1 0	£0 1 6	£0 1 6

The cost of packing for shipment and delivery f.o.b. is 6 per cent.

TUBE VICES, Fig. 3136 E represents a strong and substantial tool, intended for shop use, and constant hard wear. The frame is made of malleable iron, and is fitted with a large steel screw and steel jaws. A lighter pattern is made in the same materials suitable for tubes up to 1 1/2 inches, and may be preferred when portability is a consideration.

PRICES OF TUBE VICES, Fig. 3136 E.

For tubes	1/2 in. to 1 1/2 in.	1/2 in. to 2 in.	1/2 in. to 3 in.
Price	14/-	18/-	30/-

PRICES OF LIGHT PATTERN TUBE VICES.

For tubes	1/2 in. to 1 in.	1/2 in. to 1 1/2 in.
Price	7/6	18/6

The cost of packing for shipment and delivery f.o.b. is 6 per cent.

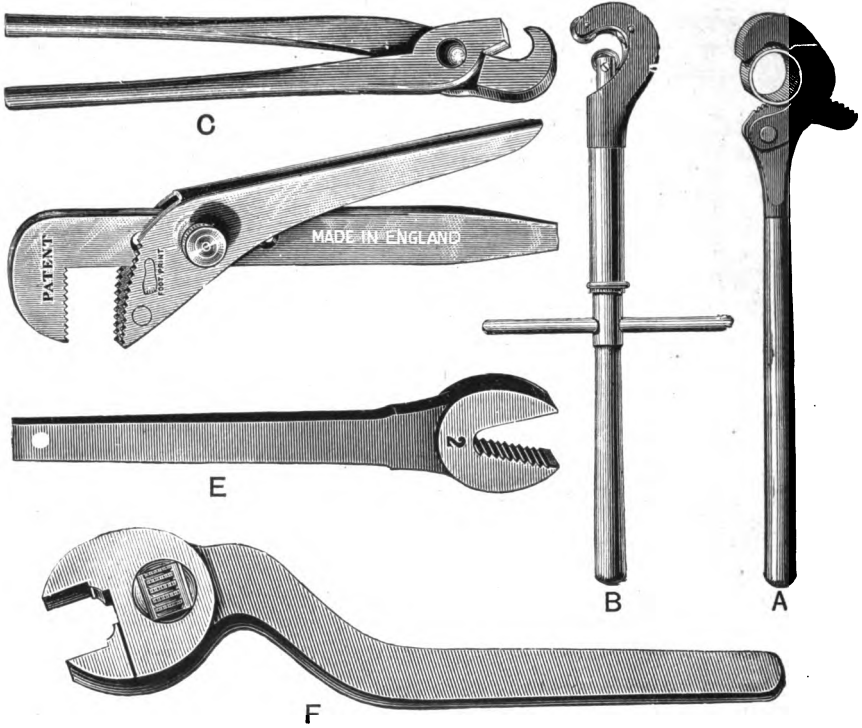

Fig. 3137.

PARROT NOSE AUTOMATIC PIPE TONGS, Fig 3137 A, are self adjusting and give a powerful grip of the tube ; they are made in wrought iron, with steel jaws.

PRICES OF PARROT NOSE PIPE TONGS, Fig. 3137 A.

For diameter of ... ins.	$\frac{1}{2}$ to $\frac{3}{4}$	$\frac{3}{4}$ to $\frac{1}{2}$	$\frac{1}{2}$ to $1\frac{1}{4}$	1 to 2	$1\frac{1}{2}$ to $2\frac{1}{2}$	$1\frac{1}{2}$ to 3	2 to 4
Price	5/6	6/6	8/6	11/6	18/6	25/-	35/-

EXTRA STRONG TUBE CUTTERS, Fig. 3137 B. These cutters are specially strong and durable, having three cutters.

PRICES OF EXTRA STRONG TUBE CUTTERS, Fig. 3137 B.

For diameter of	$\frac{1}{2}$ in. to 1 in.	1 in. to 2 in.	$1\frac{1}{2}$ in. to 3 in.
Price with 3 cutters	15/-	22/6	35/-
Do. 1 do.	12/6	18/-	30/-
Spare cutters	each	1/-	1/6	1/6
Do. pins	do.	1/-	1/6	1/6

GAS TONGS, Fig. 3137 C, represents the pattern of gas tongs in general use and are very strongly made.

PRICES OF GAS TONGS, Fig. 3137 C.

For diameter of .. ins.	$\frac{1}{2}$	$\frac{3}{8}$	$\frac{1}{2}$	$\frac{3}{4}$	1	$1\frac{1}{4}$	$1\frac{1}{2}$	$1\frac{3}{4}$	2
Price to hold pipes per doz.	17/6	20/-	27/6	28/-	32/6	39/6	52/6	56/-	61/-
Do. do. sockets ,,	23/6	24/6	28/-	32/6	39/6	49/6	55/-	60/-	67/6
If with hook part steel ,,	25/-	27/6	30/-	40/-	45/-	50/-	60/-	70/-	75/-

AUTOMATIC ADJUSTABLE PIPE TONGS, Fig. 3137 D, are made entirely of forged steel, and have an automatic grip easy to the hand.

PRICES OF ADJUSTABLE PIPE TONGS, Fig. 3137 D.

For diameter of	$\frac{1}{2}$ in. to 1 in.	$\frac{1}{2}$ in. to 2 in.	$\frac{3}{4}$ in. to 3 in.	1 in. to 4 in.
Price each	4/6	8/6	11/6	25/-

RIPLEY WRENCHES, as illustrated Fig. 3137 E, are made in best steel, hardened and finished bright; they are light simple tools and, as they have an instantaneous grip, are considered more effective than gas tongs.

PRICES OF RIPLEY WRENCHES, Fig. 3137 E.

To admit	$\frac{1}{2}$ in. to $\frac{3}{4}$ in.	$\frac{1}{2}$ in. to 1 in.	1 in. to $1\frac{1}{2}$ in.	$1\frac{1}{2}$ in. to 2 in.	2 in. to 3 in.
For tubes	$\frac{3}{8}$ in. to $\frac{1}{2}$ in.	$\frac{1}{2}$ in. to $\frac{3}{4}$ in.	$\frac{3}{4}$ in. to $1\frac{1}{4}$ in.	$1\frac{1}{4}$ in. to $1\frac{3}{4}$ in.	$1\frac{3}{4}$ in. to $2\frac{1}{2}$ in.
Price each	2/6	4/6	6/6	9/-	12/6

CLYBURN SPANNERS, Fig. 3137 F, are made in wrought iron, have case hardened jaws, and are well fitted and finished.

PRICES OF CLYBURN SPANNERS, Fig. 3137 F.

Length ins.	4	5	6	8	10	12	15	18	21	24	26	28	30
Do. span "	$\frac{3}{8}$	$\frac{1}{2}$	$\frac{5}{8}$	$\frac{3}{4}$	1	$1\frac{1}{4}$	$1\frac{1}{2}$	$1\frac{3}{4}$	2	$2\frac{1}{2}$	$2\frac{1}{2}$	$2\frac{3}{4}$	3
Price each	5/-	5/6	6/-	7/-	8/6	10/6	12/6	14/-	16/-	20/-	24/-	28/-	32/-

The cost of packing for shipment and delivery f.o.b. is 6 per cent.

THE RATCHET BRACES illustrated by Fig. 3138 A are made of wrought iron, finished bright and fitted with case hardened ratchet wheel and steel pawl spring.

PRICES OF RATCHET BRACES, Fig. 3138 A.

Size .. ins.	10	12	14	16	18	20	22	24
Price .. each	10/-	12/-	14/-	16/-	18/-	20/-	22/-	24/-

THE INTERNAL AND EXTERNAL GAUGES as illustrated by Fig. 3138 B and C respectively, are guaranteed to have been tested by a Whitworth Measuring Machine to the $\frac{1}{1000}$ th part of an inch.

PRICES OF INTERNAL AND EXTERNAL GAUGES, Fig 3138 B and C.

$\frac{1}{8}$ in. to 1 in. advancing by $\frac{1}{8}$ in., 8 sizes	£9 3 0 per set.
$1\frac{1}{8}$ in. to 2 in.	£20 3 0 .. "
$\frac{1}{2}$ in. to 1 in.	£17 1 0 .. "
$1\frac{1}{4}$ in. to 2 in.	£40 6 0 .. "
$2\frac{1}{2}$ in. to 3 in.	£18 9 0 .. "
$2\frac{1}{2}$ in. to 3 in.	£9 9 0 .. "
$3\frac{1}{2}$ in. to 4 in.	£27 3 0 .. "
$3\frac{1}{2}$ in. to 4 in.	£13 18 0 .. "

The above can be fitted into Oak or Deal Cases.

PRICES OF SINGLE SIZES, INTERNAL AND EXTERNAL.

$\frac{1}{8}$ 1/8 1/4 5/16 3/8 7/16 1/2 9/16 5/8 11/16 3/4 13/16 7/8 15/16 1 1 1/8 1 1/4 inch.	16/- 16/- 16/- 17/- 18/- 19/- 20/- 21/- 22/- 24/- 26/- 28/- 30/- 33/- 35/- 38/- 38/-	per pair.
$1\frac{1}{8}$ 1 1/2 1 5/8 1 3/4 1 7/8 1 1/2 1 9/8 1 5/8 1 11/8 1 3/4 1 13/8 1 5/8 1 15/8 2 2 1/8 inch.	41/- 41/- 44/- 44/- 47/- 47/- 50/- 50/- 56/- 56/- 61/- 61/- 66/- 66/- 69/-	per pair.
$2\frac{1}{2}$ 2 3/4 2 1/2 2 1/4 2 1/2 2 3/4 3 3 1/2 3 1/4 3 3/8 3 1/2 3 3/4 3 1/2 4 inch.	41/- 43/- 45/- 47/- 49/- 51/- 54/- 57/- 60/- 63/- 66/- 69/- 72/- 76/- 80/-	per pair

In cases where practical accuracy is required, with less expense than the internal and external gauges above referred to, those in the following lists may answer every purpose; they are made of unhardened steel, ground to an accuracy of $\frac{1}{10000}$ part of an inch, and the plug gauges above 2 inch are cored out for lightness.

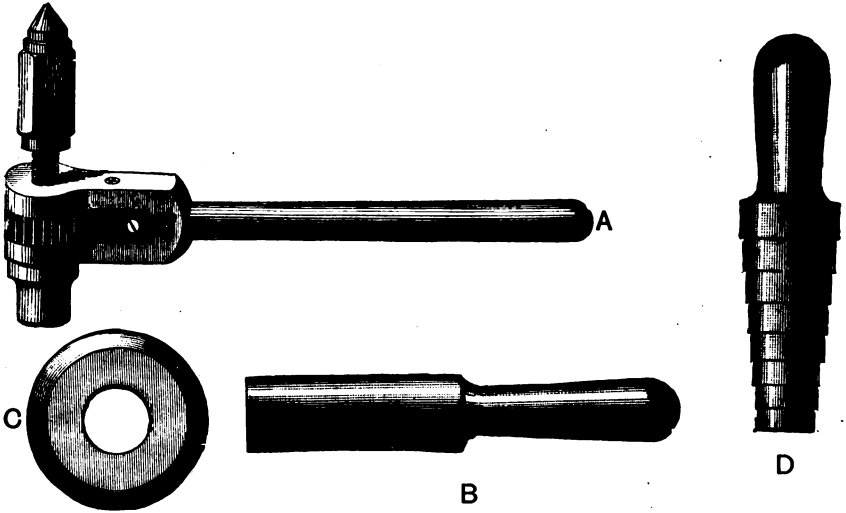

Fig. 3138.

PRICES OF INTERNAL AND EXTERNAL GAUGES AS ABOVE.

Diameter in.	$\frac{1}{8}$ and $\frac{3}{8}$	$\frac{1}{4}$ and $\frac{1}{2}$	$\frac{3}{8}$ and $\frac{5}{8}$	$1\frac{1}{8}$ and $\frac{3}{4}$	$1\frac{3}{8}$ and $\frac{7}{8}$	$1\frac{5}{8}$ and 1	$1\frac{7}{8}$ and $1\frac{1}{2}$
Total length ..	4	5	6	7	8	9	10
Price	7/-	8/-	9/-	10/-	11/-	12/-	14/-
Price of 2 rings	7/-	8/-	9/-	10/-	11/-	12/-	14/-
Diameter in.	$1\frac{3}{8}$ and $1\frac{1}{2}$	$1\frac{5}{8}$ and $1\frac{3}{4}$	$1\frac{7}{8}$ and 2	$2\frac{1}{8}$ and $2\frac{1}{4}$	$2\frac{3}{8}$ and $2\frac{1}{2}$	$2\frac{5}{8}$ and $2\frac{3}{4}$	$2\frac{7}{8}$ and 3
Total length ..	11	12	13	14	15	16	17
Price	16/-	18/-	20/-	23/-	26/-	29/-	32/-
Price of 2 rings	16/-	18/-	20/-	23/-	26/-	29/-	32/-

PRICE OF SETS OF PLUGS AND RINGS. :

$\frac{1}{8}$ in. to 1 in. diameter advancing by $\frac{1}{16}$ in., 12 sizes ..	£5 15 0	Deal case, 12/-
$1\frac{1}{8}$ in. to 2 in. " " " $\frac{1}{8}$ in., 8 sizes ..	£6 15 0	" 15/-
$2\frac{1}{8}$ in. to 3 in. " " " $\frac{1}{8}$ in., 8 sizes ..	£11 0 0	" £1

PRICES OF STEP GAUGES. Fig. 3138 D.

I Gauge, containing 6 sizes, $\frac{1}{8}$ in. to $\frac{1}{2}$ in. by $\frac{1}{16}$ in.	£1 7 0
I " " " 8 " $\frac{3}{8}$ in. to 1 in. by $\frac{1}{16}$ in.	£1 17 6
I " " " 8 " $1\frac{1}{8}$ in. to $1\frac{1}{2}$ in. by $\frac{1}{16}$ in.	£3 0 0
I " " " 8 " $1\frac{3}{8}$ in. to 2 in. by $\frac{1}{16}$ in.	£3 14 0
I " " " 7 " $\frac{1}{2}$ in. to 1 in. by $\frac{1}{8}$ in.	£1 15 0
I " " " 8 " $1\frac{1}{8}$ in. to 2 in. by $\frac{1}{8}$ in.	£3 10 0
I " " " 8 " $2\frac{1}{8}$ in. to 3 in. by $\frac{1}{8}$ in.	£3 12 0
I " " " 8 " $3\frac{1}{8}$ in. to 4 in. by $\frac{1}{8}$ in.	£5 0 0

Special quotations for larger sizes.

PRICES OF MICROMETER CALIPERS, (not illustrated).

No. ..	1	2	3	4	5	6	7	8
Capacity in.	0 to ½	0 to ½	0 to 1	0 to 1	0 to 1	0 to 1	0 to 2	0 to 2
Readings ..	1000	1000	1000	1000	1000	1000	1000	1000
Meas. points	bevelled	bevelled	bevelled	bevelled	bevelled and clampscrew	flush	bevelled	bevelled and clampscrew
Price ..	18/9	23/-	21/-	25/-	23/-	25/-	33/6	36/6
Cases extra	2/-	2/-	2/6	2/6	2/6	2/6	2/6	2/6

IMPROVED VERNIER CALIPER, (not illustrated).

These are very handy Gauges and form complete inside and outside calipers, and have points to transfer the distance. One side reads to 1000 part of an inch, and the other is marked 64ths or 50ths of an inch to read without a Vernier. The points are of tempered steel, and the jaws are ground.

These instruments are enclosed in a morocco case, and instructions for using are given with each. If desired, one side will be marked in millimetres without extra charge.

PRICE OF VERNIER CALIPERS.

6 inch	£3 3 0
12 ,,	£4 4 0
24 ,,	£5 5 0

French Vernier on back side at same prices.

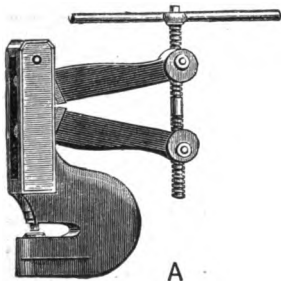

A

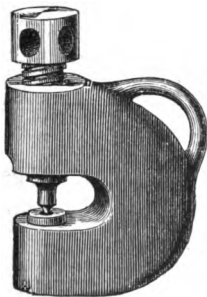

B

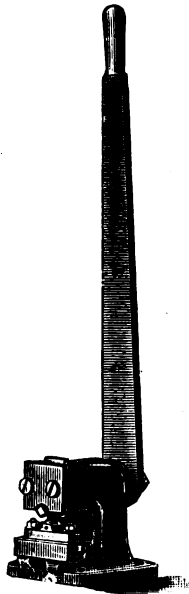

C

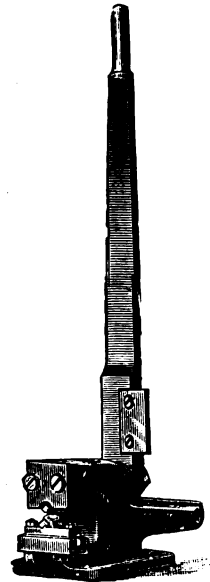

D

Fig. 3139.

PUNCHING BEARS AND LEVER PUNCHING AND SHEARING MACHINES, as illustrated by Fig. 3139, are specially adapted for use by shipbuilders, bridge and roof builders, boiler makers, plate-layers, &c. The tools are made of forged steel with steel screws or levers, the punching bears **A** and **B** being especially strong and durable, and unlikely to get out of repair.

The duplex punching bear is made with open mouth as illustrated, Fig. 3139 **A**, or with closed mouth, when it is specially suitable for punching iron or steel rails.

PRICES OF DUPLIX PUNCHING BEARS, Fig. 3139 A.

To punch holes in diameter	$\frac{1}{2}$ in.	$\frac{3}{8}$ in.	$\frac{3}{8}$ in.	$\frac{7}{8}$ in.
Do. iron plates, thick	$\frac{1}{2}$ in.	$\frac{3}{8}$ in.	$\frac{3}{8}$ in.	$\frac{7}{8}$ in.
Depth of gap	$1\frac{1}{8}$ in.	$1\frac{1}{8}$ in.	2 in.	$2\frac{1}{8}$ in.
Price with one punch and die	£3 10 0	£4 10 0	£6 10 0	£10 10 0
Approximate weight lbs	18	36	81	120
Price per pair round punches and dies ..	4/-	5/-	5/-	6/-
Do. do. oval or square do.	8/-	10/-	10/-	12/-

If punches and dies of less than $\frac{1}{2}$ in. and $\frac{3}{8}$ in. diameter respectively are used with the two smallest machines, holders will be required, and the price of these is 4/- per pair.

PRICES OF DUPLIX PUNCHING BEARS WITH CLOSED MOUTH.

To punch up to $1\frac{1}{2}$ in. diameter holes in $\frac{3}{4}$ in. iron rail	} £17. 10 0
Do. do. $1\frac{1}{2}$ in. do. do. $\frac{1}{2}$ in. steel rail	

PRICES OF EXTRA PUNCHES AND DIES FOR ABOVE.

Size of hole	$\frac{1}{2}$ in.	$\frac{3}{8}$ in.	$\frac{7}{8}$ in.	1 in.	$1\frac{1}{2}$ in.	$1\frac{1}{2}$ in.
Price per pair, round	4/-	5/-	6/-	7/-	7/6	10/-
Do. do. oval or square	8/-	10/-	12/-	14/-	15/-	20/-

A section of the rail to be punched should be sent with the order for these bears.

PRICES OF SCREW PUNCHING BEARS, Fig. 3139 B.

To punch holes in diameter	$\frac{1}{2}$ in.	$\frac{3}{8}$ in.	$\frac{7}{8}$ in.
Do. iron plates, thick	$\frac{1}{2}$ in.	$\frac{3}{8}$ in.	$\frac{7}{8}$ in.
Price with one punch and die	£2 10 0	£3 0 0	£4 10 0
Approximate weight lbs.	23	36	56
Price per pair punches and dies	10/-	11/-	12/-

PRICES OF LEVER PUNCHING MACHINES, Fig. 3139 C.

To punch holes in diameter	$\frac{1}{2}$ in.	$\frac{3}{8}$ in.	$\frac{1}{2}$ in.
Do. iron plates, thick	$\frac{1}{2}$ in.	$\frac{3}{8}$ in.	$\frac{1}{2}$ in.
Depth of gap	$1\frac{1}{2}$ in.	3 in.	4 in.
Price with one punch and die	£2 10 0	£6 0 0	£9 10 0
Approximate weight cwts.	$\frac{1}{2}$	1	2
Price per pair punches and dies	3/-	3/6	5/-

PRICES OF LEVER PUNCHING AND SHEARING MACHINES, Fig. 3139 D.

To punch holes in diameter	$\frac{1}{2}$ in.	$\frac{5}{8}$ in.
Do. iron plates, thick	$\frac{3}{8}$ in.	$\frac{1}{2}$ in.
Do. shear bars	$\frac{1}{2}$ in.	$\frac{1}{2}$ in.
Depth of gap	$1\frac{1}{2}$ in.	$2\frac{1}{8}$ in.
Price complete	£3 0 0	£4 5 0
Approximate weight cwts.	$\frac{1}{2}$	$1\frac{1}{2}$
Price per pair punches and dies	3/-	8/6
Do. do. blades	5/6	6/6

These machines are specially suited for cutting hoop iron for baling, &c.

The cost of packing for shipment and delivery is f.o.b. 10 per cent.

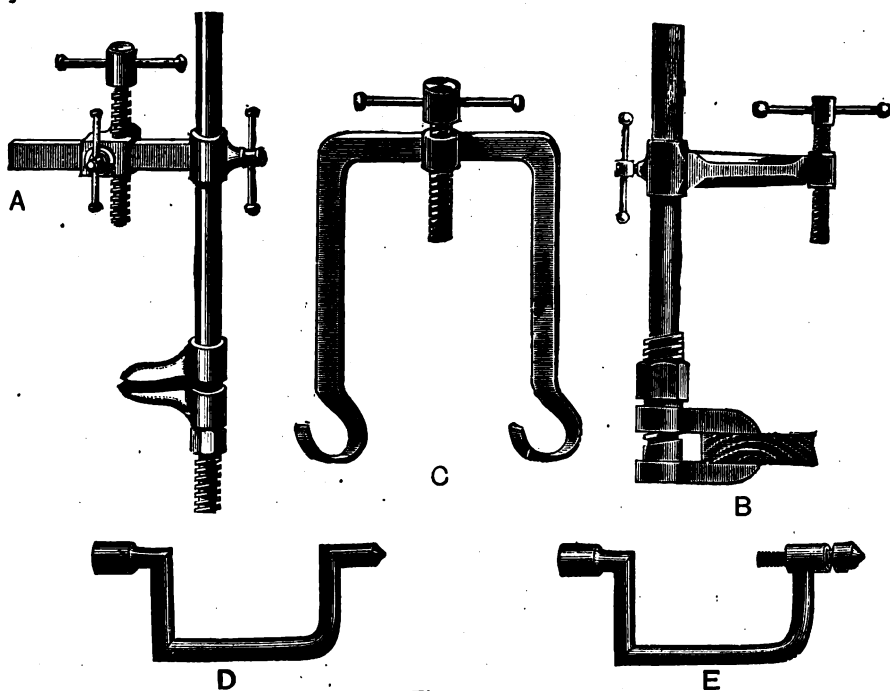

Fig. 3140.

DRILLING PILLARS AND CRAMPS. AND CRAMP BRACES, Fig. 3140, clearly illustrated by the above engravings, are so generally well known that detailed description will be unnecessary.

PRICES OF DRILLING PILLARS AND CRAMPS, AND CRANK BRACES, Fig. 3140.

Type A	Drilling Pillar, 1 1/8 in. diameter, 28 in. high	32/-
" "	do. 1 1/8 in. do. 31 in. high	38/-
" B	do. (heavier pattern than above) 31 in. high	43/-
" "	do. if fitted with slide on arm	53/-
" C	Drilling Cramps for 2 in. to 4 in. diameters	20/-
" "	do. do. 4 in. to 6 in. "	27/6
" "	do. do. 5 in. to 8 in. "	35/-
" D	Crank Brace, without drills	8/6
" "	do. with drills	20/6
" E	do. with feed screw, without drills	10/6
" "	do. do. do. with drills	22/6

The cost of packing for shipment and delivery f.o.b. is 6 per cent.

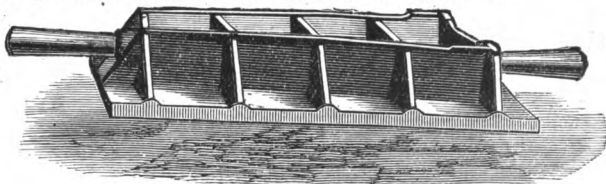

Fig. 3141.

SURFACE PLATES are made of close grained tough cast iron, strongly ribbed to guard against distortion and provided with handles as indicated in Fig. 3141.

The faces are carefully machined and scraped to a true surface, three plates of the same size being made at the same time, so that they may be tested with each other and be finished with the requisite accuracy.

PRICES OF SURFACE PLATES, Fig. 3141.

Size	in.	12 by 12	12 by 18	18 by 18	18 by 24	24 by 24	24 by 36	24 by 48
Price	..	£2 10	£3 15	£5 12 6	£7 10	£9 15	£15	£18 10

WROUGHT IRON SPANNERS, made from the best wrought iron, by special machines are produced at a cost which admits of their use instead of those made of malleable cast iron.

These spanners are not liable to break and being case hardened are very durable. The double ended pattern can be made in any combination of sizes.

PRICES OF WROUGHT IRON SPANNERS.

SINGLE ENDS.				DOUBLE ENDS.			
Size of Gap.	Length.	Price, Japanned and hardened per doz.	Price with bright jaws and hardened per doz.	Size of Gap.	Length.	Price, Japanned and hardened per doz.	Price with bright jaws and hardened per doz.
		£ s. d.	£ s. d.			£ s. d.	£ s. d.
1 in.	6 in.	0 6 0	0 12 0	1/2 by 3/8 in.	5 in.	0 5 9	0 11 6
1 in.	7 in.	0 6 6	0 13 0	3/8 by 1/2 in.	6 in.	0 6 6	0 13 0
1 in.	8 in.	0 7 6	0 15 0	1/2 by 5/8 in.	7 in.	0 7 6	0 15 0
1 in.	10 in.	0 12 0	1 0 0	3/4 by 7/8 in.	10 in.	0 15 6	1 4 0
1 in.	12 in.	0 15 6	1 5 0	1 by 1 1/8 in.	14 in.	1 1 6	1 10 0
1 1/8 in.	14 in.	0 18 0	1 6 0	1 1/4 by 1 3/8 in.	16 in.	1 9 0	1 18 0
1 1/4 in.	15 in.	1 2 0	1 10 0	1 1/2 by 1 5/8 in.	18 in.	1 15 6	2 7 6
1 1/2 in.	16 in.	1 3 0	1 11 0	1 3/4 by 1 7/8 in.	20 in.	2 4 0	2 18 0
1 3/4 in.	17 in.	1 5 0	1 14 0	2 by 2 1/8 in.	24 in.	2 15 0	3 10 0
1 in.	18 in.	1 6 0	1 16 0	2 1/4 by 2 3/8 in.	28 in.	3 8 0	4 5 0
1 in.	19 in.	1 8 0	1 17 6	2 1/2 by 2 5/8 in.	32 in.	4 5 0	5 5 0
1 1/2 in.	20 in.	1 12 0	2 5 0	2 3/4 by 3 in.	36 in.	4 15 0	5 15 0
2 in.	22 in.	1 15 0	2 10 0				
2 1/4 in.	24 in.	2 0 0	2 15 0				
2 1/2 in.	26 in.	2 4 0	3 0 0				
2 3/4 in.	28 in.	2 7 6	3 5 0				
2 1/2 in.	30 in.	2 10 0	3 7 6				
2 3/4 in.	32 in.	2 15 0	3 10 0				
2 3/4 in.	34 in.	3 5 0	4 2 0				
3 in.	36 in.	3 12 0	4 5 0				

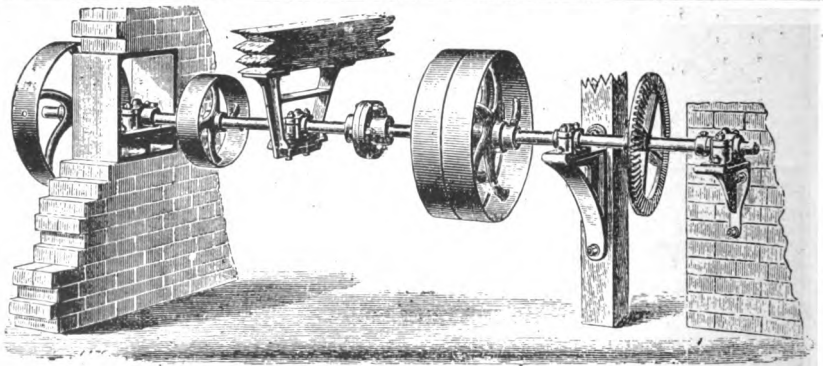

Fig. 3142.

WROUGHT IRON AND STEEL SHAFTING AND ACCESSORIES, Fig. 3142, indicates the type of shafting, bearings, couplings, pulleys, &c. in general use for transmitting power to machines of almost every kind.

Many devices have been adopted with a view of obtaining higher efficiency in the transmission of power and for reducing the loss arising from undue friction. Some of these will be referred to in detail and, as regards shafting, experience has amply proved that a small saving in the cost of shafting, bearings, &c, is very soon converted into a loss, by excessive friction, owing to imperfect proportion, workmanship or materials.

The distances between bearings necessarily vary in proportion with the work on the shaft, and other circumstances, but the average will be as indicated in the following tables.

Diameter of shaft ins.	1	1 1/4	1 1/2	1 3/4	2	2 1/4	2 1/2	2 3/4	3	3 1/4	3 1/2	4
Distance of Bearings..	5' 0"	6' 0"	7' 0"	7' 6"	8' 0"	8' 6"	9' 0"	9' 6"	10' 0"	10' 6"	11' 0"	12' 0"

PRICES OF WROUGHT IRON AND STEEL SHAFTING.

Diameter inches	1	1 1/4	1 1/2	1 3/4	2	2 1/4
Price of wrought iron shafting per foot	1/-	1/2	1/4	1/6	1/9	2/2
Weight of ditto per foot, lbs.	2.62	4.09	5.90	8.03	10.49	13.27
Price of steel shafting .. per foot	1/2	1/4	1/6	1/10	2/2	2/8
Weight of ditto .. per foot, lbs.	2.67	4.17	6.02	8.19	10.70	13.54
Diameter inches	2 1/2	2 3/4	3	3 1/4	3 1/2	4
Price of wrought iron shafting per foot	2/8	3/4	3/10	4/6	5/2	6/10
Weight of ditto per foot, lbs.	16.39	19.84	23.60	27.70	32.13	41.97
Price of steel shafting .. per foot	3/2	3/8	4/6	5/3	6/-	7/6
Weight of ditto .. per foot, lbs.	16.72	20.24	24.07	28.25	32.77	42.81

Intermediate sizes are charged at the price of the next size larger.

Fractions of six inches in length are charged as six inches.

Lengths exceeding 20 feet and less than 10 feet cost ten per cent. extra.

PRICES OF LOOSE SET COLLARS, FLANGED COUPLINGS, AND PLUMMER BLOCKS, Fig. 3142.

Diameter of shaft	1	1 1/4	1 1/2	1 3/4	2	2 1/4	2 1/2	2 3/4	3	3 1/4	3 1/2	4
Heavy wrt. iron set collars each	1/9 2/	2/3	2/6	3/-	3/6	4/-	4/6	5/-	5/6	6/-	7/-	7/-
Cast iron ditto	10d 1/-	1/2	1/4	1/6	1/9	2/-	2/3	2/6	2/9	3/-	3/6	3/6
Flanged Couplings per pair	6/- 6/6	7/6	9/6	12/-	14/-	18/-	21/-	25/-	28/-	32/-	40/-	40/-
Do. with recessed bolts ,,	8/6 9/6	10/-	13/-	16/-	20/-	23/-	27/6	32/-	37/6	42/-	50/-	50/-
Keying on and facing on ..	4/- 4/6	5/-	6/-	6/8	7/6	8/-	9/-	10/-	12/-	13/-	15/-	15/-
Plummer blocks or pedestals each	3/6 4/-	5/6	7/-	9/-	11/6	14/6	17/6	22/6	28/-	37/-	48/-	48/-

Fixed collars, welded upon the shafts and turned, cost the same as the heavy wrought iron set collars :

If the set collars are fitted with two set screws, the extra cost is 6d. each.

The Plummer blocks or pedestals are planed on the sole, bored, faced and fitted with top and bottom gunmetal bearings, of ample surface.

PRICES OF HANGERS, WALL BOXES, BRACKETS &c., Fig. 3142.

Diameter of shaft .. inches	1	1 1/4	1 1/2	1 3/4	2	2 1/4	2 1/2	2 3/4	3
Hangers each									
Wall brackets	12/-	13/6	16/-	19/6	24/-	29/6	36/-	43/6	52/-
Standards									
Slings									
Sling with detachable base ,,	13/3	15/-	17/6	21/6	26/6	32/6	39/6	48/-	57/-
Sill plate	10/-	10/9	12/3	14/6	17/6	21/3	25/9	31/-	37/-
Angle bracket									
Raised sill plate	11/-	12/-	14/-	17/-	21/-	25/-	31/-	37/-	45/-
Wall box 4 1/2 in. wide ..									
Do. 9 in. wide	12/-	13/6	16/-	19/6	24/-	29/6	36/-	43/6	52/-

PRICES OF MUFF COUPLINGS AND CLUTCH COUPLINGS.

Diameter of shaft .. in.	1	1½	1¾	1⅞	2	2½	2¾	2⅞	3
Price of muff coupling ea.	11/-	11/-	12/6	15/-	18/-	21/-	25/-	30/-	35/-
Do. clutch do. ,,	13/6	14/6	16/6	19/6	22/6	25/6	31/6	34/-	39/6

Intermediate sizes are charged at the price of the next size larger.

Packing for shipment and delivery f.o.b. costs 6 per cent.

CAST IRON SPUR OR BEVEL WHEELS, are made of high-class metal and machine moulded so that great accuracy is obtained, and the shape of tooth is specially designed to transmit the maximum power without undue friction or noise. The proportions of each wheel are as follows, unless otherwise ordered,

Width inches	2	3	4	5	6	7	8	9	10	11	12
Pitch ,,	1	1½	1¾	1⅞	2	2½	2¾	2⅞	3	3½	3¾
Spur wheels will transmit in H. P.	½	¾	1	1½	2	3½	4½	6½	8½	11½	14½
Bevil wheel do. do.	½	¾	1	1½	2	3½	4½	6½	8½	11	14

and the horse power transmitted is for every hundred feet of circumferential velocity per minute.

Double flanged wheels are one third stronger than unflanged gear wheels.

Helical gear wheels are one fifth stronger than unflanged gear wheels.

Mortice gear wheels are one fourth weaker than unflanged gear wheels.

PRICES OF SPUR AND BEVEL WHEELS.

Diameter in inches.	Width of face in inches.										
	2	3	4	5	6	7	8	9	10	11	12
6	28/9	32/6
9	31/3	36/3	42/6	50/-	57/6
12	33/9	40/-	47/6	55/-	63/9	72/6	82/6	93/9
15	36/3	43/9	52/6	61/3	71/3	81/3	93/9	106/3	120/-	135/-	151/3
18	38/9	47/6	57/6	67/6	78/9	90/-	105/-	120/-	136/3	153/9	172/6
21	41/3	51/3	62/6	73/9	86/3	100/-	116/3	133/9	152/6	172/6	193/9
24	45/-	55/-	67/6	80/-	93/9	110/-	127/6	147/6	168/9	191/3	215/-
27	48/9	60/-	72/6	86/3	102/6	120/-	138/9	116/3	185/-	210/-	236/3
30	52/6	65/-	78/9	93/9	111/3	130/-	150/-	175/-	201/3	228/9	257/6
33	56/3	70/-	85/-	101/3	120/-	140/-	162/6	190/-	217/6	247/6	280/-
36	60/-	75/-	91/3	108/9	128/9	150/-	175/-	205/-	235/-	267/6	302/6
39	65/-	80/-	97/6	116/3	137/6	161/3	187/6	220/-	252/6	287/6	325/-
42	70/-	85/-	103/9	123/9	146/3	172/6	200/-	235/-	270/-	307/6	347/6
45	75/-	90/-	110/-	131/3	155/-	183/9	213/9	250/-	287/6	327/6	370/-
48	80/-	95/-	116/3	138/9	165/-	195/-	227/6	265/-	305/-	347/6	393/9
51	85/-	101/3	122/6	146/3	175/-	206/3	241/3	280/-	322/6	367/6	417/6
54	90/-	107/6	128/9	155/-	185/-	217/6	255/-	295/-	340/-	387/6	441/3
57	95/-	113/9	136/3	163/9	195/-	228/9	268/9	311/3	357/6	408/9	465/-
60	100/-	120/-	143/9	172/6	205/-	241/3	282/6	327/6	376/3	430/9	488/9
63	..	126/3	151/3	181/3	216/3	253/9	297/6	343/9	395/-	452/6	512/6
66	..	132/6	160/-	191/3	227/6	266/3	312/6	360/-	413/9	475/-	537/6
69	..	140/-	168/9	201/3	238/9	280/-	327/6	377/6	433/9	497/6	562/6
72	..	147/6	177/6	211/3	250/-	293/9	342/6	395/-	453/9	520/-	588/9

Gear wheels of intermediate diameters are priced in proportion.

Gear wheels of intermediate width are charged at the price of the next size larger.

Gear wheels made in halves cost 20 per cent extra.

Gear wheels made with flange on one side cost 15 per cent extra.

Gear wheels made with flanges on both sides cost 25 per cent extra.

Gear wheels made with double helical gear cost 25 per cent extra.

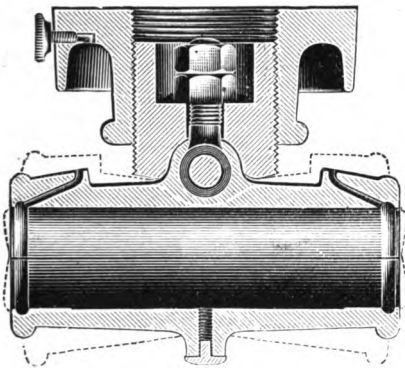

Fig. 3143.

ADJUSTABLE BEARINGS FOR SHAFTING. If users of machinery recognised the constant loss of power caused by bearings being out of line with driving shaft, adjustable bearings would unquestionably be used much more generally than they are. Many arrangements have been devised for easily and quickly adjusting bearings vertically and horizontally and that illustrated by Fig. 3143, may be taken as a favourable example of them.

As indicated in the engraving, the bottom half of the bearing and the top part of the socket form a knuckle joint connected by eye bolt. This admits of the bearing being readily adjusted in a vertical direction; the horizontal adjustment is affected by simply revolving the screwed plug which carries the above named socket.

Another advantage of these bearings is their length relatively with the diameter of the shaft and, a minor one is, that the bearing is provided with oil passage through which the waste oil is conducted into the cups formed in the base and is drawn off by removing a screwed plug. Larger sizes than are referred to below are subject to special quotation.

PRICES OF ADJUSTABLE BEARINGS, Fig. 3143.

Bore	1½ in.	1¾ in.	2 in.	2¼ in.	2½ in.	2¾ in.	3 in.
Length of bearing ..	6 in.	7 in.	8 in.	9 in.	10 in.	11 in.	12 in.
Do. sole	8½ in.	8¾ in.	11¼ in.	11½ in.	15¼ in.	15½ in.	16½ in.
Width of sole.. ..	2½ in.	2¾ in.	3¼ in.	3½ in.	4½ in.	4¾ in.	5 in.
Price each	10/-	11/6	12/6	15/-	17/6	22/6	27/6

HANGERS WITH ADJUSTABLE BEARINGS, as Fig. 3143, are made of the dimensions and at the prices given in the list, or larger sizes are made if desired.

Either open (J) or double side (sling) hangers are supplied at the undernamed prices and orders should state which type is required.

PRICES OF HANGERS WITH ADJUSTABLE BEARINGS.

Diameter of shaft	1½ in.	1¾ in.	2 in.	2¼ in.	2½ in.	2¾ in.	3 in.
Depth 10 in. to centre of shaft ..	13/-	14/-
Do. 13 in. do. do. ..	14/6	15/6	20/-	21/-	25/6	28/-	..
Do. 16 in. do. do. ..	16/-	17/-	21/-	22/-	27/-	30/-	37/6
Do. 19 in. do. do. ..	18/6	19/6	22/-	23/-	29/-	31/6	40/-
Do. 22 in. do. do.	31/6	33/-	42/6
Do. 25 in. do. do.	45/-

WALL BRACKETS WITH ADJUSTABLE BEARINGS, as Fig. 3143, are usually made of the undernamed sizes, but any other dimension can be supplied.

Diameter of shaft	1½ in.	1¾ in.	2 in.	2¼ in.	2½ in.	2¾ in.	3 in.
Overhang 10 in. to centre of shaft	15/-	16/6
Do. 13 in. do. do. ..	16/6	18/-	21/-	23/6	30/-	35/-	..
Do. 16 in. do. do. ..	18/6	20/-	22/6	25/-	32/6	37/6	42/6
Do. 19 in. do. do. ..	20/6	22/-	25/-	27/6	35/-	40/-	45/-
Do. 22 in. do. do.	37/6	42/-	47/6
Do. 25 in. do. do.	40/-	45/-	50/-

WALL BOXES WITH ADJUSTABLE BEARINGS AS Fig. 3143.

Diameter of shaft	1½ in.	1¾ in.	2 in.	2½ in.	2¾ in.	3 in.	3 in.
Price of box 4½ in. wide with bearing ..	16/-	17/6	20/6	23/-	29/-	34/-	..
Do. 9 in. do. do.	27/6	30/-	35/-	40/-	50/-

DRIVING PULLEYS. The following information relates to the types of pulleys in general use and it may be well to point out that pulleys for **non shifting belts** should be ½ an inch wider than the driving belt and be rounded on the face. Those for **shifting belts** should be flat on the face and ½ an inch wider than **double** the width of the belt.

Much delay and inconvenience will be avoided if orders are accompanied by accurate information on the following points:—

Whether the pulleys are to be “split” or “whole.”

The exact diameter of the shafts or (by preference) templates for these.

Whether they are to be flat or round faced.

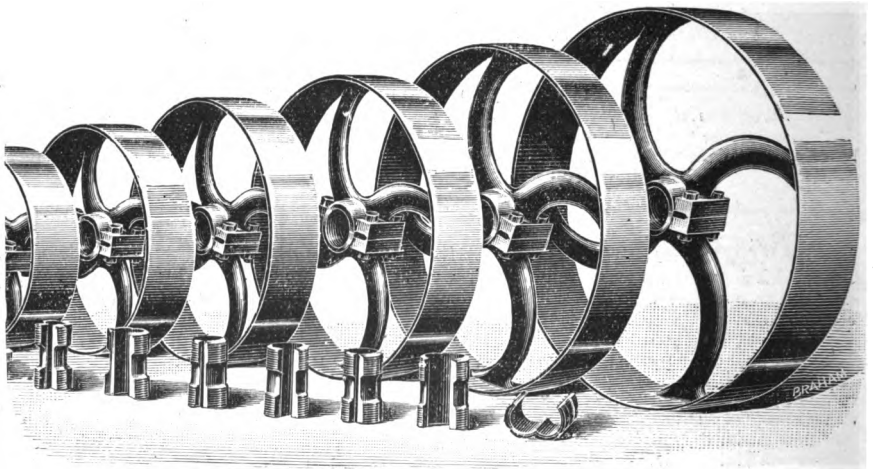

Fig. 3144.

CAST IRON PULLEYS WITH SCREW BOSSES as Fig. 3144, can be fixed on a shaft of almost any diameter, without keys and key seats, but pulleys with ordinary bosses, bored and key seated will also be supplied at the undernamed prices.

The cost of pulleys of widths between those given in the list, will be ascertained by adding half the difference between the price of the next narrower and the next wider pulley, thus—one 20 in. diameter and 11 in. wide costs 30/-. Pulleys exceeding 12 in. wide, or if extra strong are subject to special quotations

The subjoined prices refer to pulleys with bosses bored to from 1½ in. to 3 in. diameter for sizes up to 36 in. diameter. From 38 in. to 72 in. diameter the bosses are bored to from 1½ in. to 4½ in. diameter. If these dimensions are exceeded the cost of boring the first named up to 4½ diameter and the last named up to 6 in. diameter is 2/- and 3/6 respectively.

It should be stated whether a screw or ordinary boss is required, also see remarks under the heading “driving pulleys.”

PRICES OF SCREW BOSS PULLEYS, Fig. 3144.

WHOLE PULLEYS							SPLIT PULLEYS							
Diam. in Inches.	WIDTH ON FACE, IN INCHES.						Diam. in Inches.	WIDTH ON FACE, IN INCHES.						Diam. in Inches.
	4	5	6	8	10	12		4	5	6	8	10	12	
7	9/	10/	11/	7	12/6	13/6	14/6	7
8	9/	10/	11/	13/	8	12/6	13/6	14/6	16/6	8
9	10/	11/	12/	14/	9	13/6	14/6	15/6	17/6	9
10	11/	12/	13/	15/	18/	..	10	14/6	15/6	16/6	18/6	21/6	..	10
11	11/	12/	13/	15/	18/	..	11	14/6	15/6	16/6	18/6	21/6	..	11
12	11/	12/	13/	15/	18/	22/	12	15/6	16/6	17/6	19/6	22/6	26/6	12
13	12/	13/	14/	16/	19/	23/	13	16/6	17/6	18/6	20/6	23/6	27/6	13
14	13/	14/	15/	18/	20/	24/	14	17/6	18/6	19/6	22/6	24/6	28/6	14
15	14/	15/	16/	19/	22/	26/	15	18/6	19/6	20/6	23/6	26/6	30/6	15
16	15/	16/	17/	20/	24/	28/	16	19/6	20/6	21/6	24/6	28/6	32/6	16
17	16/	17/	18/	21/	25/	29/	17	20/6	21/6	22/6	25/6	29/6	33/6	17
18	16/	17/	18/	22/	26/	30/	18	20/6	21/6	22/6	26/6	30/6	34/6	18
19	17/	18/	19/	23/	27/	31/	19	21/6	22/6	23/6	27/6	31/6	35/6	19
20	17/	18/	20/	24/	28/	32/	20	22/6	23/6	25/6	29/6	33/6	37/6	20
21	18/	20/	21/	25/	29/	33/	21	23/6	25/6	26/6	30/6	34/6	38/6	21
22	18/	20/	22/	26/	30/	34/	22	23/6	25/6	27/6	31/6	35/6	39/6	22
23	20/	22/	24/	28/	32/	36/	23	25/6	27/6	29/6	33/6	37/6	41/6	23
24	20/	23/	25/	29/	33/	38/	24	25/6	28/6	30/6	34/6	38/6	43/6	24
25	21/	24/	26/	31/	35/	40/	25	26/6	29/6	31/6	36/6	40/6	45/6	25
26	22/	25/	28/	32/	36/	42/	26	27/6	30/6	33/6	37/6	41/6	47/6	26
27	23/	26/	29/	33/	38/	44/	27	28/6	31/6	34/6	38/6	43/6	49/6	27
28	24/	27/	30/	35/	40/	46/	28	29/6	32/6	35/6	40/6	45/6	51/6	28
29	25/	28/	31/	36/	41/	47/	29	30/6	33/6	36/6	41/6	46/6	52/6	29
30	26/	29/	32/	37/	42/	48/	30	32/6	35/6	38/6	43/6	48/6	54/6	30
31	27/	30/	33/	39/	44/	50/	31	33/6	36/6	39/6	45/6	50/6	56/6	31
32	28/	31/	34/	40/	45/	51/	32	34/6	37/6	40/6	46/6	51/6	57/6	32
33	29/	32/	35/	41/	47/	53/	33	35/6	38/6	41/6	47/6	53/6	59/6	33
34	30/	33/	36/	42/	49/	55/	34	36/6	39/6	42/6	48/6	55/6	61/6	34
35	31/	34/	37/	44/	50/	56/	35	37/6	40/6	43/6	50/6	56/6	62/6	35
36	32/	35/	38/	45/	51/	57/	36	38/6	41/6	44/6	51/6	57/6	63/6	36
38	35/	38/	41/	49/	55/	62/	38	41/6	44/6	47/6	55/6	61/6	68/6	38
39	36/	39/	43/	51/	59/	69/	39	43/6	46/6	50/6	58/6	66/6	76/6	39
40	38/	41/	45/	53/	62/	72/	40	45/6	48/6	52/6	60/6	69/6	79/6	40
42	41/	45/	49/	57/	66/	78/	42	48/6	52/6	56/6	64/6	73/6	85/6	42
44	43/	47/	51/	59/	69/	81/	44	50/6	54/6	58/6	66/6	76/6	88/6	44
45	45/	49/	53/	61/	71/	84/	45	52/6	56/6	60/6	68/6	78/6	91/6	45
46	48/	52/	56/	64/	74/	87/	46	55/6	59/6	63/6	71/6	81/6	94/6	46
48	50/	54/	58/	66/	77/	90/	48	57/6	61/6	65/6	73/6	84/6	97/6	48
50	61/	70/	81/	93/	50	70/6	79/6	90/6	102/6	50
51	63/	73/	84/	96/	51	72/6	82/6	93/6	105/6	51
54	68/	78/	90/	104/	54	77/6	87/6	99/6	113/6	54
57	74/	84/	96/	112/	57	83/6	93/6	105/6	121/6	57
60	80/	90/	102/	120/	60	89/6	99/6	111/6	129/6	60
63	96/	101/	112/	130/	63	108/6	113/6	124/6	142/6	63
66	104/	109/	120/	140/	66	116/6	121/6	132/6	152/6	66
69	112/	117/	130/	150/	69	124/6	129/6	142/6	162/6	69
72	120/	125/	140/	160/	72	132/6	137/6	152/6	172/6	72

CAST IRON PULLEYS, with ordinary bosses, indicated in Fig. 3142, are suitable for general engineering purposes, and are turned flat or round on face as may be preferred but unless otherwise ordered they are finished flat.

PRICES OF STRONG CAST IRON PULLEYS, Fig. 3142.

Diam. in Inches.	WHOLE PULLEYS						SPLIT PULLEYS						
	WIDTH ON FACE, IN INCHES.						WIDTH ON FACE, IN INCHES.						
	4	5	6	8	10	12	3	4	5	6	8	10	12
6	5/6	6/0	5/9	6/6	7/0
7	6/0	6/6	7/0	6/0	7/0	7/6	8/0
8	6/6	7/0	7/6	6/6	7/6	8/0	8/6
9	7/0	7/6	8/6	11/0	7/0	8/0	8/6	9/6	12/6
10	7/6	8/0	9/0	11/6	7/6	8/6	9/0	10/0	13/0
11	8/0	9/0	10/0	12/6	15/6	..	8/0	9/0	10/6	11/6	14/6	17/6	..
12	8/6	9/6	10/6	13/0	16/0	..	8/6	9/6	11/0	12/0	15/0	18/0	..
13	9/0	10/0	11/0	14/0	17/0	21/0	9/0	10/6	11/6	12/6	16/0	19/0	23/6
14	9/6	10/6	11/6	14/6	18/0	22/0	9/6	11/0	12/0	13/0	16/6	20/0	24/6
15	10/0	11/0	12/0	15/0	19/0	23/0	10/0	11/6	12/6	13/6	17/0	21/0	25/6
16	10/6	11/6	12/6	15/6	19/6	24/6	10/6	12/0	13/0	14/0	17/6	21/6	27/0
17	11/0	12/0	13/0	16/0	20/0	25/0	11/0	12/6	13/6	14/6	18/0	22/0	27/6
18	12/0	13/0	14/0	17/0	21/0	26/0	11/6	14/6	16/0	17/0	20/0	25/0	30/6
19	13/0	14/0	15/0	18/0	22/6	27/6	..	15/6	17/0	18/0	21/6	26/6	32/0
20	14/0	15/0	16/0	19/6	24/0	29/0	..	16/6	18/0	19/0	23/0	28/0	33/6
21	15/0	16/0	17/0	20/6	25/0	30/0	..	17/6	19/0	20/0	24/0	29/0	34/6
22	16/0	17/0	18/0	21/6	26/0	31/0	..	18/6	20/0	21/0	25/0	30/0	35/6
23	17/0	18/0	19/6	23/6	28/0	33/0	..	19/6	21/0	22/6	27/0	32/0	37/6
24	18/0	19/0	20/6	24/6	29/6	34/6	..	20/6	22/0	23/6	28/0	33/6	39/0
25	19/0	20/0	21/6	26/0	31/0	36/0	..	21/6	23/0	24/6	29/6	35/0	40/6
26	20/0	21/6	23/6	28/0	33/0	39/0	..	23/0	25/0	27/0	32/0	37/6	44/0
27	21/0	22/6	24/6	29/0	34/6	41/0	..	24/0	26/0	28/0	33/0	39/0	46/0
28	22/0	23/6	25/6	30/0	36/0	42/6	..	25/0	27/0	29/0	34/0	40/6	47/6
29	23/0	24/6	26/6	31/0	37/0	44/0	..	26/0	28/0	30/0	35/0	41/6	49/0
30	24/0	25/6	27/6	32/0	38/0	46/0	..	27/0	29/0	31/0	36/0	42/6	51/0
31	25/0	26/6	28/6	33/0	40/0	48/0	..	28/0	30/0	32/0	37/0	44/6	53/0
32	27/0	29/0	31/0	35/0	42/0	50/0	..	30/6	33/0	35/0	39/6	47/0	56/0
33	28/0	30/0	32/0	37/0	44/0	52/6	..	31/6	34/0	36/0	41/6	49/0	58/6
34	29/0	31/0	33/0	38/0	45/6	55/0	..	32/6	35/0	37/0	42/6	50/6	61/0
36	31/0	33/0	35/0	40/0	47/6	57/6	..	34/6	37/0	39/0	44/6	52/6	63/6
38	..	35/0	37/6	43/0	50/0	60/0	39/6	42/0	48/0	56/0	67/6
39	..	36/0	38/6	44/0	52/6	62/6	40/6	43/0	49/0	58/6	70/0
40	..	37/6	40/0	46/0	55/0	65/0	42/0	44/6	51/0	61/0	72/6
42	..	41/0	44/0	51/0	60/0	70/0	45/6	48/6	56/0	66/0	77/6
44	..	44/0	47/6	56/0	65/0	75/0	48/6	52/0	61/0	72/6	85/0
45	..	46/0	48/0	58/0	67/6	77/6	50/6	52/6	63/0	75/0	87/6
46	..	47/0	50/0	60/0	70/0	80/0	51/6	54/6	65/0	77/6	90/0
48	..	50/0	55/0	65/0	75/0	85/0	54/6	59/6	70/0	82/6	95/0
50	69/0	80/0	90/0	75/0	90/0	102/6
52	72/6	85/0	95/0	78/6	95/0	107/6
54	75/0	87/6	100/0	81/0	97/6	112/6
56	80/0	92/6	105/0	87/6	102/6	117/6
58	85/0	97/6	110/0	92/6	107/6	122/6
60	90/0	102/6	117/6	97/6	112/6	130/0

These pulleys are cast from well proportioned iron patterns, the bosses are bored to suit shafting from 1½ in. to 3 in. for sizes up to 38 ins. diameter, and the larger sizes can be bored for 4 in. shafting if desired. For extra large bosses a charge is made for altering the pattern.

All the prices include the cost of cutting key-ways, and fitting with set screws.

Pulleys narrower than those priced above are charged the same as the next size wider.

Cast iron pulleys if with flange on one side the cost is 15 per cent extra.

Cast iron pulleys if with flange on both sides the cost is 20 per cent extra.

Cast iron pulleys if with one flange in middle the cost is 20 per cent extra.

Cast iron pulleys made suitable for running fast and loose cost 10 per cent extra.

In measuring the width of flanged pulleys both sides of flange or flanges must be included.

HAULAGE ROPE PULLEYS, with steel arms cast solid into the rim and boss which are of cast iron, are usually made 4½ ins. wide with a groove 3 ins. deep, so that any rope not exceeding 1½ in. diameter will run freely in the bottom of the groove clear of the sides.

PRICES OF HAULING ROPE PULLEYS.

Diameter at bottom of groove	18in.	24in.	30in.	36in.	42in.	48in.	60in.	72in.
Price, bored and slotted including key ..	33/-	42/-	57/-	72/-	104/-	133/-	182/-	208/-

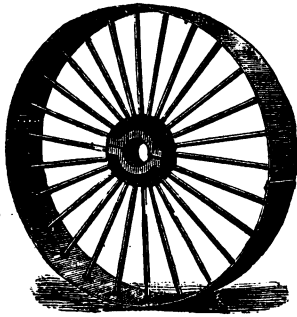

Fig. 3145

WROUGHT IRON PULLEYS, Fig. 3145 with ordinary bosses. The subjoined prices refer to pulleys with single arms turned true on the face.

Orders for pulleys should state whether they are to have rounded or flat faces and whether whole or in halves.

Double armed pulleys are made of any size between 12 in. diameter by 12 in. wide and 60 in. by 24 in. wide and the prices may be ascertained by taking the cost of two pulleys of the diameter required one half the width.

The hole in the boss is assumed to be 1 in. diameter for each foot diameter of pulley.

The extra cost of larger holes is 2/- for each inch or fraction of an inch in excess of the above named proportions.

PRICES OF WROUGHT IRON PULLEYS, Fig. 3145.

Diam. in Inches.	WIDTH ON FACE, IN INCHES.										Diam. in Inches.
	3	4	5	6	7	8	9	10	11	12	
12	14/0	15/6	16/6	18/0	20/0	22/0	24/0	26/6	30/0	33/0	12
14	15/0	16/6	17/6	19/0	21/0	22/6	25/0	27/6	31/0	34/0	14
16	17/0	18/0	19/0	20/6	22/6	24/0	26/6	29/0	32/6	35/6	16
18	18/0	20/0	22/0	24/0	25/6	27/6	29/6	30/6	34/0	36/6	18
20	19/6	22/0	24/6	26/6	28/6	30/0	31/6	33/0	35/0	38/0	20
22	22/6	24/0	27/0	29/6	31/6	33/0	35/0	37/0	39/0	41/0	22
24	25/0	27/6	29/6	32/0	34/0	36/0	38/0	40/0	42/0	44/0	24
26	28/0	30/0	32/6	35/0	37/0	39/0	41/6	43/6	45/6	48/0	26
28	31/6	34/0	35/6	37/6	40/0	42/6	44/6	47/6	49/6	51/6	28
30	33/0	35/6	38/0	40/0	42/6	44/6	46/6	49/0	51/6	55/0	30
32	35/6	37/6	40/0	42/6	45/0	47/6	50/0	52/6	55/0	57/6	32
34	37/6	40/0	42/6	45/0	47/6	50/0	52/6	55/0	57/6	60/0	34
36	40/0	42/6	45/0	47/6	50/0	52/6	55/0	57/6	60/0	63/0	36
38	45/0	48/0	51/0	52/6	55/0	57/6	60/0	63/0	67/0	70/0	38
40	47/0	50/0	53/0	56/0	59/0	62/0	65/0	68/0	72/0	75/0	40

PRICES OF WROUGHT IRON PULLEYS, Fig. 3145—Continued.

Diam. in Inches.	WIDTH ON FACE, IN INCHES.										Diam. in Inches.
	3	4	5	6	7	8	9	10	11	12	
42	49/0	52/6	56/0	59/6	62/6	65/6	68/6	72/6	75/6	80/0	42
44	55/6	59/0	63/0	66/0	69/0	72/0	75/0	79/0	83/0	86/0	44
46	60/0	63/0	66/0	69/0	72/0	75/0	78/0	82/0	86/0	90/0	46
48	62/6	65/6	68/6	71/0	74/0	77/0	80/0	84/0	88/0	92/0	48
50	67/6	70/6	73/6	76/0	79/0	82/0	85/0	89/0	93/0	97/0	50
52	72/6	75/6	78/6	81/0	84/0	87/0	90/0	94/0	98/0	102/0	52
54	77/6	80/6	83/6	86/0	89/0	92/0	95/0	99/0	103/0	107/0	54
56	82/6	85/6	88/6	91/0	94/0	97/0	100/0	104/0	108/0	112/0	56
58	87/6	90/6	93/6	96/0	99/0	102/0	105/0	109/0	113/0	117/0	58
60	92/6	95/6	98/6	101/0	104/0	107/0	110/0	114/0	119/0	122/0	60
62	98/6	101/6	104/6	107/0	110/0	113/0	116/0	120/0	124/0	128/0	62
64	104/6	107/6	110/6	113/0	116/0	119/0	122/0	126/0	130/0	134/0	64
66	110/6	113/6	116/6	119/0	122/0	125/0	128/0	132/0	136/0	140/0	66
68	116/6	119/6	122/6	125/0	128/0	131/0	134/0	138/0	142/0	146/0	68
70	122/6	125/6	128/6	131/0	134/0	137/0	140/0	144/0	148/0	152/0	70
72	128/6	131/6	134/6	137/0	140/0	143/0	146/0	150/0	154/0	158/0	72
74	134/6	137/6	140/6	143/0	146/0	149/0	152/0	156/0	160/0	164/0	74
76	140/6	143/6	146/6	149/0	152/0	155/0	158/0	162/0	166/0	170/0	76
78	148/0	151/0	154/0	156/6	159/6	162/6	165/6	169/6	173/6	177/6	78
80	158/0	161/0	164/0	167/6	169/6	172/6	175/6	179/6	183/6	187/6	80
82	168/0	171/0	174/0	177/0	179/6	182/6	185/6	189/6	193/6	197/6	82
84	178/0	181/0	184/0	187/0	189/6	192/6	195/6	199/6	203/6	207/6	84
86	188/0	191/0	194/0	197/0	199/6	202/6	205/6	209/6	213/6	217/6	86
88	198/0	201/0	204/0	207/0	209/6	212/6	215/6	219/6	223/6	227/6	88
90	210/0	213/0	216/0	219/0	221/6	224/6	227/6	231/6	235/6	239/6	90
92	222/0	225/0	228/0	231/0	233/6	236/6	239/6	243/6	247/6	251/6	92
94	234/0	237/0	240/0	243/0	245/6	248/6	251/6	255/6	259/6	263/6	94
96	246/0	249/0	252/0	255/0	257/6	260/6	263/6	267/6	271/6	275/6	96
98	260/0	263/0	266/0	269/0	271/6	274/6	277/6	281/6	285/6	289/6	98
100	274/0	277/0	280/0	283/0	285/6	288/6	291/6	295/6	299/6	303/6	100

FAST AND LOOSE PULLEYS are supplied at the same prices as above, a small extra charge being made for preparing boss pattern and facing each pulley, drilling hole, &c., which amounts to 3/6 for pulleys up to 36ins. diameter and 5/6 up to 48ins. diameter.

WROUGHT IRON PULLEYS with screw bosses as described under Fig. 3144 with wrought iron arms as Fig. 3145.

Diam. in Inches.	WIDTH ON FACE, IN INCHES.										Diam. in Inches.
	4	5	6	7	8	9	10	11	12		
16	20/6	22/0	23/0	25/0	26/6	29/0	31/0	32/6	34/6	16	
18	22/6	24/6	26/6	28/0	29/6	31/0	33/0	35/0	37/0	18	
20	24/6	27/0	29/0	31/0	32/6	34/0	35/6	37/6	39/6	20	
22	26/6	30/0	32/0	34/0	36/0	38/0	40/0	42/0	44/0	22	
24	30/0	32/0	34/6	36/6	38/6	40/6	42/6	44/6	46/6	24	
26	32/6	35/0	37/6	39/6	41/6	44/0	46/0	48/0	50/6	26	
28	36/6	38/0	40/0	42/6	45/0	47/0	50/0	52/0	54/0	28	
30	38/0	41/0	42/6	45/0	47/0	49/0	51/6	54/0	57/6	30	

PRICES OF WROUGHT IRON PULLEYS WITH SCREW BOSSES—Continued.

Diam. in Inches.	WIDTH ON FACE, IN INCHES.										Diam. in Inches.
	4	5	6	7	8	9	10	11	12		
32	40/0	43/0	45/0	47/6	50/0	52/6	55/0	57/6	60/0	32	
34	42/6	45/0	47/6	50/0	52/6	55/0	57/6	60/0	62/6	34	
36	45/0	47/6	50/0	52/6	55/0	57/6	60/0	62/6	65/6	36	
38	50/6	54/0	56/0	57/6	60/0	62/6	65/6	69/6	72/6	38	
40	52/6	56/0	58/6	61/6	64/6	67/6	71/6	74/6	77/6	40	
42	55/0	59/0	62/0	65/0	68/0	71/0	75/0	78/0	82/6	42	
44	61/6	66/0	68/6	72/6	74/6	77/6	81/6	85/6	88/6	44	
46	65/6	68/6	71/6	74/6	77/6	80/6	84/6	88/6	92/6	46	
48	68/6	71/6	74/0	76/6	79/6	82/6	86/6	90/6	94/6	48	
50	71/6	75/6	78/6	81/6	84/6	87/6	91/6	95/6	99/6	50	
52	75/6	79/6	82/6	86/6	89/6	92/6	96/6	100/6	104/6	52	
54	78/6	83/6	86/6	90/6	94/6	97/6	101/6	105/6	109/6	54	
56	83/6	87/6	91/6	95/6	99/6	102/6	106/6	110/6	114/6	56	
58	87/6	91/6	95/6	100/6	104/6	108/6	112/6	115/6	119/6	58	
60	92/6	96/6	100/6	105/6	109/6	114/6	118/6	122/6	126/6	60	
62	97/6	101/6	105/6	110/6	114/6	119/6	123/6	128/6	132/6	62	
64	102/6	107/6	111/6	116/6	120/6	125/6	129/6	134/6	138/6	64	
66	108/6	113/6	117/6	122/6	126/6	131/6	135/6	140/6	144/6	66	
68	115/6	119/6	123/6	128/6	132/6	137/6	141/6	146/6	150/6	68	
70	121/6	125/6	129/6	133/6	138/6	143/6	147/6	152/6	156/6	70	
72	127/6	131/6	136/6	141/6	145/6	149/6	154/6	158/6	162/6	72	
74	134/6	138/6	142/6	147/6	152/6	156/6	160/6	164/6	168/6	74	
76	142/6	146/6	150/6	155/6	159/6	162/6	167/6	170/6	174/6	76	
78	151/6	155/6	158/6	162/6	166/6	170/6	174/6	177/6	181/6	78	
80	159/6	163/6	166/6	170/6	174/6	178/6	181/6	184/6	188/6	80	
82	167/6	171/6	174/6	178/6	182/6	186/6	189/6	192/6	196/6	82	
84	175/6	179/6	182/6	186/6	190/6	194/6	198/6	201/6	205/6	84	
86	183/6	186/6	190/6	194/6	198/6	202/6	206/6	210/6	214/6	86	
88	190/6	194/6	198/6	203/6	207/6	211/6	215/6	219/6	223/6	88	
90	198/6	202/6	206/6	211/6	215/6	219/6	224/6	228/6	232/6	90	
92	206/6	210/6	214/6	219/6	224/6	228/6	233/6	238/6	242/6	92	
94	214/6	218/6	222/6	227/6	232/6	237/6	242/6	247/6	252/6	94	
96	222/6	226/6	230/6	236/6	241/6	246/6	252/6	257/6	262/6	96	
98	230/6	234/6	238/6	244/6	250/6	255/6	261/6	266/6	272/6	98	
100	238/6	242/6	246/6	252/6	258/6	264/6	270/6	276/6	282/6	100	
102	245/6	249/6	254/6	261/6	267/6	273/6	280/6	286/6	292/6	102	
104	252/6	257/6	262/6	269/6	276/6	282/6	289/6	296/6	302/6	104	
106	260/6	265/6	270/6	278/6	285/6	292/6	299/6	306/6	313/6	106	
108	267/6	272/6	278/6	286/6	294/6	301/6	309/6	316/6	324/6	108	
110	274/6	280/6	286/6	294/6	303/6	311/6	319/6	327/6	335/6	110	
112	282/6	288/6	294/6	303/6	312/6	320/6	329/6	337/6	346/6	112	
114	290/6	296/6	302/6	312/6	321/6	330/6	339/6	348/6	357/6	114	
116	298/6	304/6	310/6	320/6	330/6	340/6	349/6	359/6	368/6	116	
118	306/6	313/6	320/6	331/6	341/6	350/6	360/6	370/6	380/6	118	
120	315/6	324/6	332/6	342/6	352/6	361/6	371/6	382/6	392/6	120	

Wrought iron pulleys supplied up to 20 ft. diameter.

Prices from 10 ft. diameter on application.

PATENT WOOD SPLIT PULLEYS are much lighter than iron pulleys and, the inventors claim that they transmit more power by reason of the greater grip the strap has on them. By using the patent bushes any pulley can be fixed to almost any size of shaft.

PRICES OF WOOD SPLIT PULLEYS.

Diam. in Inches.	WIDTH OF FACE, IN INCHES.											
	3	4	5	6	7	8	9	10	12	14	16	18
9	10/3	11/0	12/1	13/2	13/9	14/0
10	10/10	11/6	12/7	13/7	14/3	14/10	15/6	16/3
11	11/8	12/4	13/4	14/9	15/5	16/1	17/0	17/11	21/3
13	12/1	12/11	14/2	15/8	16/8	17/9	18/11	20/0	23/4
14	12/6	13/7	15/2	17/1	18/4	19/7	20/11	22/4	25/0	27/6
15	12/11	14/5	16/1	18/2	19/10	21/3	22/10	24/5	27/1	30/2
16	13/9	15/3	16/11	19/2	21/1	22/11	24/7	26/3	29/2	32/1
17	14/7	16/1	17/9	20/3	22/4	24/5	26/3	27/11	31/6	34/5
18	15/5	16/11	19/0	21/4	23/7	25/10	28/7	29/9	33/1	37/6	44/8	..
19	..	17/9	20/0	22/11	25/7	28/2	29/10	31/3	35/10	40/10	48/9	..
20	..	18/8	21/8	25/0	27/6	29/10	31/9	33/4	39/7	45/10	52/6	..
22	..	20/8	24/7	28/8	31/1	33/4	36/3	39/2	46/8	54/2	59/2	..
24	..	22/7	26/6	30/6	33/7	36/8	40/4	43/8	53/0	62/11	73/0	..
26	..	26/6	29/3	33/2	36/9	40/0	41/10	47/6	59/3	73/0	86/9	100/6
28	..	30/0	32/6	35/10	39/9	43/0	46/9	50/6	63/8	79/3	95/10	112/0
30	..	33/4	35/10	39/3	43/8	48/0	51/9	55/3	68/9	87/6	105/10	125/0
32	..	36/8	39/3	43/0	48/6	53/9	58/3	62/6	74/9	94/9	115/9	134/6
34	..	40/0	4/9	48/0	54/3	60/6	65/9	71/0	83/6	102/0	125/0	143/9
36	..	44/3	49/6	54/3	60/6	66/9	73/3	79/9	93/9	110/6	135/0	154/6
38	..	54/3	57/3	60/6	66/9	73/6	79/9	86/3	103/4	118/9	143/9	163/6
40	..	53/6	60/9	66/6	73/0	79/3	86/6	93/9	111/6	129/6	151/0	173/0
42	..	64/9	66/9	73/0	81/3	89/9	98/0	104/6	121/0	139/6	160/6	182/6
44	..	70/6	73/0	81/3	90/0	99/0	106/9	114/9	131/0	150/0	169/9	192/0
46	..	79/0	81/6	92/0	99/6	109/0	117/0	125/0	139/9	161/0	179/9	200/0
48	..	87/0	91/6	102/0	110/6	117/0	127/0	135/6	149/6	172/0	189/0	210/0
50	113/0	124/0	131/6	139/9	148/0	162/6	183/0	209/0	235/0
52	129/0	135/6	141/6	150/0	158/6	175/0	192/0	219/0	250/0
54	139/6	148/0	156/0	163/6	171/0	187/6	206/6	239/6	269/0
56	154/0	161/6	169/0	177/0	185/6	202/0	223/0	250/0	290/0
58	169/0	176/0	181/6	191/0	198/0	218/0	241/0	268/0	308/0
60	177/0	186/0	196/0	205/6	215/0	234/0	259/0	285/6	325/0
66	196/0	206/0	215/0	224/0	239/0	265/0	298/0	334/0	371/0
72	215/0	224/0	239/0	250/0	267/0	298/0	335/0	375/0	417/0

The prices of intermediate widths are in proportion.

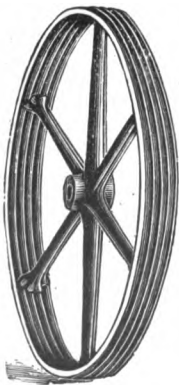

Fig. 3146.

PATENT WROUGHT IRON PULLEYS WITH PERFORATED RIMS are not illustrated but are similar in construction to the wrought iron pulley shewn by Fig. 3145 with the exception that the rim, instead of being plain on the face, is perforated with a number of small holes to give the belt a better grip and thus avoid loss in the transmission of power arising from slip; another important feature is that the belt does not get overheated.

The price of these pulleys whether solid or split, flat or round on the face of the rim, is the same as the wrought iron pulleys with single arms, Fig. 3145.

CAST IRON PULLEYS FOR ROPE DRIVING, Fig. 3146, with grooves for ropes turned and the bosses bored and key-seated, are supplied at the prices given in the following table.

GROOVED FLY WHEELS and pulleys exceeding 6 ft. in diameter are made to special quotations.

PRICES OF CAST IRON ROPE PULLEYS, Fig. 3146.

Diameter—Inches.	18	24	30	36	42	48	56	60	66	72
1 groove for lin. dia. rope	24/0	30/0	39/0	48/0	57/0	66/0	78/0	84/0	93/0	102/0
2 grooves " "	34/0	40/0	53/6	67/0	80/6	94/0	112/0	121/0	134/6	148/0
3 " " "	44/0	50/0	68/0	86/0	104/0	122/0	146/0	158/0	176/0	194/0
4 " " "	48/0	60/0	82/6	105/0	127/6	150/0	180/0	195/0	217/6	240/0
5 " " "	58/0	70/0	97/0	124/0	151/0	178/0	214/0	232/0	259/0	286/0
6 " " "	68/0	80/0	111/6	143/0	174/6	206/0	248/0	269/0	300/6	332/0
1 " 1½ in. "	60/0	75/0	90/0	110/0	120/0	135/0	150/0
2 " " "	77/0	98/0	119/0	147/0	161/0	182/0	203/0
3 " " "	97/0	124/0	151/0	187/0	205/0	232/0	259/0
4 " " "	120/0	153/0	186/0	230/0	252/0	285/0	318/0
5 " " "	145/0	184/0	223/0	275/0	301/0	340/0	379/0
6 " " "	173/0	218/0	263/0	323/0	353/0	398/0	443/0
1 " 2 in. "	120/0	144/0	156/0	174/0	192/0
2 " " "	150/0	182/0	198/0	222/0	246/0
3 " " "	185/0	225/0	245/0	275/0	305/0
4 " " "	225/0	273/0	297/0	353/0	369/0
5 " " "	270/0	326/0	354/0	396/0	438/0
6 " " "	320/0	384/0	416/0	464/0	512/0

The prices of intermediate sizes are in proportion.

The prices of pulleys suitable for 1½ in. or 1¾ in. ropes are midway between those of 1 in. and 1½ in., and 1½ in. and 2 in. respectively.

Pulleys cast in halves cost 10 per cent extra, and 5/- in addition

DRIVING BELTS made of leather, hair, india-rubber, and cotton, all possess advantages when used under different conditions, but leather continues to be much the most generally used; in tropical climates, highly saturated with moisture, or for use in wet places anywhere, hair or rubber belting is usually found very satisfactory, and in hot dry climates cotton belting gives excellent results

In order to obtain the combined advantages of these belts, they may be made of two or more substances sewn together in any combination, and the approximate cost of such a belt may be obtained by adding the price of the separate belts together; this kind of belt is however not recommended except under special conditions.

All belts are sewn with hemp, thong, or copper wire as may be preferred, without any difference in the cost, but unless otherwise specified, hemp sewing is supplied.

All these belts can be made more or less impervious to wet, but for working under the worst conditions, and for heavy driving, a patent belt composed of gutta percha, canvas, and balata is recommended, and the prices of such belts will be found below.

Link leather belting effectually grips the pulleys, but the cost is considerably higher than that of most other belting as will be seen from the list of prices given below.

PRICES PER FOOT OF BEST SINGLE AND DOUBLE LEATHER BELTING.

Width .. inches	1	1½	1¾	2	2	2½	2¾	2¾	3	3½	3½
Price single belting ..	-/4	-/5½	-/7	8/-	-/9	-/10	1/-	1/2	1/4	1/5½	1/7½
Do. double do.	1/9	2/-	2/2	2/6	2/7	2/10	3/2
Width .. inches	3¾	4	4½	4½	4¾	5	5½	6	6½	7	7½
Price single belting ..	1/9	1/11	2/-	2/2	2/3½	2/6	2/8½	2/11	3/3	3/7	3/11
Do. double do. ..	3/5	3/7	3/10	4/1	4/3	4/6	4/10	5/4	6/-	6/6	7/2
Width .. inches	8	8½	9	9½	10	10½	11	11½	12	13	14
Price single belting ..	4/3	4/6	4/10	5/1	5/5	5/8	6/-	6/3	6/6	7/-	7/6
Do. double do. ..	7/11	8/5	8/11	9/5	10/-	10/10	11/6	12/1	12/7	13/6	15/-
Width .. inches	15	16	17	18	19	20	22	24	26	30	36
Price double belting ..	16/-	17/6	18/6	20/-	21/-	22/-	24/-	26/-	28/-	33/-	39/-

PRICES OF ENDLESS LEATHER BANDS FOR PORTABLE ENGINES.

	STOUT SINGLE BELTS.			STOUT DOUBLE BELTS.			LIGHT DOUBLE BELTS.		
	60ft.	65ft.	70ft.	60ft.	65ft.	70ft.	60ft.	65ft.	70ft.
Length ..	60ft.	65ft.	70ft.	60ft.	65ft.	70ft.	60ft.	65ft.	70ft.
Width, 4½ ins.	£6 5	£6 15	£7 6	£12 0	£13 0	£14 6	£11 0	£11 19	£12 17
Do. 5 "	£7 5	£7 17	£8 9	£13 10	£14 12	£15 15	£12 0	£13 0	£14 0
Do. 5½ "	£7 15	£8 8	£9 0	£14 10	£15 14	£16 18	£13 1	£14 3	£15 4
Do. 6 "	£8 5	£8 19	£9 12	£15 15	£17 2	£18 13	£14 8	£15 12	£16 16

PRICES PER FOOT OF HAIR BELTING.

Width inches	2	2½	2¾	2⅞	3	3¼	3½	3¾	4	4¼	4½	4¾
Price ..	-/7	-/8	-/9	-/10	1/-	1/1½	1/3	1/4½	1/6	1/7½	1/9	1/10½
Width inches	5	5½	6	6½	7	7½	8	8½	9	9½	10	11
Price ..	2/-	2/3	2/6	2/9	3/-	3/4	3/8	4/-	4/4	4/8	5/-	5/8
Width inches	12	13	14	15	16	18	20	22	24	26	28	30
Price ..	6/4	7/-	7/8	8/4	9/-	10/4	12/-	14/-	16/-	18/-	20/-	22/-

PRICES PER FOOT OF COTTON SEWN DUCK BELTING.

Width inches	1½	1¾	2	2¼	2½	2¾	3	3¼	4	5	6	7	8
Price, 4 ply. ..	-/4½	-/5½	-/6	-/6½	-/7½	-/8½	-/9	-/10½	1/-	1/3	1/6
Do. 6 " "	1/-	1/2	1/4	1/8	2/-	2/4	2/8
Do. 8 " "	2/6	2/11	3/4
Width inches	9	10	12	15	18	24	30	36	40	44	48	54	60
Price, 6 ply. ..	3/-	3/4	4/-
Do. 8 " " ..	3/9	4/2	5/-	6/3	6/3	10/-	12/6
Do. 10 " "	6/-	7/6	9/-	12/-	15/-	18/-	20/-	22/-	24/-	27/-	30/-

PRICES PER FOOT OF GUTTA PERCHA, CANVAS, AND BALATA BELTING.

Width inches	1	1½	2	2½	3	3½	4	4½	5	5½	6	7	8	10	12
Price, 3 ply. ..	-/2	-/3	-/4	-/6½	-/7½	-/9½	-/10½	1/-	1/1½	1/3	1/4	1/5½	1/9½	2/5	3/1½
Do. 4 " "	-/8½	-/10½	1/-	1/2	1/4	1/5½	1/7½	1/9½	2/1½	2/7	3/2½	3/10
Do. 5 " "	1/4	1/6	1/9	1/9	2/1½	2/3	2/7	3/1	3/10	4/5½
Do. 6 " "	2/8	2/11½	3/7	4/10	6/1	..

All endless belts are charged at 3 feet extra.

PRICES PER FOOT OF LINK LEATHER BELTING.

Width inches	2	2½	3	3½	4	4½	5	5½	6	6½	7	7½	8	8½	9
Price, No. 1	-/11	1/2	1/4	1/6	1/9	2/1	2/4
Do. " 2	1/2	1/6	1/10	2/2	2/6	2/9	3/-	3/4	3/9
Do. " 3	1/8	2/-	2/5	2/10	3/2	3/7	4/1	4/5	4/9	5/2	5/7	6/-	6/5	6/10	7/2
Do. " 4	1/10	2/2	2/7	3/-	3/5	3/10	4/4	4/9	5/2	5/7	6/-	6/6	6/11	7/4	7/10
Width inches	9½	10	10½	11	11½	12	15	18	21	24	27	30	33	36	
Price, No. 3	7/7	8/-	8/4	8/9	9/1	9/6	12/-	14/4	16/9	19/-	21/6	24/-	26/4	28/8	
Do. " 4	8/3	8/9	9/2	9/6	10/-	10/4	12/10	15/6	18/-	20/9	23/6	26/2	28/10	30/5	

PRICE PER FOOT OF INDIA RUBBER BELTING.

Width inches	1	1½	1¾	1⅞	2	2½	2¾	2⅞	3
Price, 2 ply.	-/3½	-/4½	-/5	-/6	-/6½	-/7½	-/7¾	-/8½	-/9½
Do. 3	-/4½	-/5½	-/6½	-/7½	-/8½	-/9½	-/10½	-/11½	1/3½
Do. 4
Do. 5
Do. 6
Width inches	3½	3¾	3⅞	4	4½	5	5½	6	6½
Price, 2 ply.	-/10½	-/10¾	-/11½	1/0½	1/1½	1/3	1/4½	1/6	1/7½
Do. 3	1/1	1/1½	1/3	1/3½	1/6	1/7½	1/9½	1/11½	2/1½
Do. 4	1/4½	1/6	1/7½	1/8½	1/11	2/1½	2/4	2/6½	2/9
Do. 5	2/6	2/9	3/-	3/3
Do. 6	2/10½	3/2½	3/5½	3/8½
Width inches	7	8	9	10	11	12	13	14	16
Price, 2 ply.	1/9	2/-	2/3½	2/6	2/9	3/-	3/3	3/6	4/-
Do. 3	2/3½	2/7½	2/10½	3/3	3/7½	3/10½	4/2½	4/6	5/1½
Do. 4	2/11½	3/4½	3/9	4/2½	4/7½	5/0½	5/5½	5/10	6/8½
Do. 5	3/6	4/-	4/6	5/-	5/6	6/-	6/6	7/-	8/-
Do. 6	4/-	4/6½	5/1½	5/8½	6/3	6/9½	7/4½	7/11½	9/1½
Do. 8	7/2½	7/10½	8/7½	9/3½	10/-	11/6
Do. 10	10/4½	11/3½	12/2½	14/-
Width inches	18	20	22	24	26	28	30	48	
Price, 2 ply.	4/6	5/1½	5/6½	6/-	6/6	7/-	7/6	12/-	
Do. 3	5/9½	6/4½	7/0½	7/8½	8/4	9/-	9/8½	15/9½	
Do. 4	7/6	8/4½	9/3	10/1½	10/11½	11/9½	12/7½	20/7½	
Do. 5	9/-	10/-	11/-	12/-	13/-	14/-	15/-	24/-	
Do. 6	10/3½	11/6	12/7½	13/9½	15/-	16/1½	17/3½	28/-	
Do. 8	12/10½	14/4½	15/9½	17/2½	18/7½	20/1½	21/7½	35/-	
Do. 10	15/9½	17/7½	19/5	21/2½	23/0½	24/10½	26/9½	43/9½	

The belting is made in rolls of 300 ft.

PRICES OF LEATHER LACES AND ACCESSORIES.

Length	2ft.	2½ft.	3ft.	3½ft.	4ft.	4½ft.	5ft.	5½ft.	6ft.
" Helvetia " laces, sewing, per gross	9/-	14/-	19/-	26/-	28/-	36/-	46/-	62/-	73/-
Do. do. lashing ..	9/-	14/-	23/-	29/-	36/-	44/-	56/-	68/-	78/-
White ox hide laces, sewing	4/4	7/6	9/-	11/6	17/-	22/-	24/-	30/-	32/-
Do. do. lashing ..	6/6	10/-	12/6	17/6	25/-	30/-	35/-	45/-	50/-
Hooks and eyes	¼in.	⅝in.	¾in.	⅞in.	1in.	1¼in.	1½in.	1¾in.	2in.
Price per pair	-/7	-/10	1/2	1/7	2/5	3/3	5/-	5/-	5/-
Patent Belt Fasteners	½in.	1in.	1½in.	2in.	2½in.	2¾in.	3in.	3½in.	4in.
Price per gross	4/-	6/-	8/-	10/-	11/-	12/-	13/-	14/-	16/-

FILES AND RASPS—Flat, Half-round, Square, Round, Entering, Taper Cotter, Horse Shoe, Flat, and Half-round Rasps. Mill Saws, one or two Square Edges, Single and Double Cut. Topping Files, Single and Double, left at point, and Safe Edges as List A.

Three-Square, Hand. Equaling one Safe Edge, Parallel Cotter, Pillar, Needle, Round off, Bone, Pottance, Round Edged Flat, Extra Thin Flat, and Flat and High-back Half-round as List B.

PRICES OF FILES AND RASPS.

LIST A.	Rough and Bastard.	2nd Cut Flat and 1-Edged Gun- stockers and Round Rasps.		Smooth and Cabinet Files and Rasps.	Dead Smooth and Extra Smooth Cabinets.
		Per Dozen.	Per Dozen.		
Inches. 1 to 4	£ s. d.	£ s. d.	£ s. d.	£ s. d.	£ s. d.
4	0 4 9	0 5 6	0 6 9	0 10 3	0 11 3
5	0 5 8	0 6 0	0 7 3	0 11 3	0 12 6
6	0 6 9	0 6 9	0 8 0	0 12 6	0 13 6
7	0 7 0	0 7 8	0 9 0	0 13 6	0 14 6
8	0 7 6	0 8 9	0 10 6	0 15 9	0 16 6
9	0 8 6	0 9 9	0 11 6	0 17 6	0 18 6
10	0 9 6	0 10 9	0 12 3	0 18 6	0 19 6
11	0 10 6	0 12 0	0 13 6	1 0 0	1 1 0
12	0 11 0	0 12 9	0 14 6	1 2 0	1 3 0
13	0 12 0	0 13 6	0 15 6	1 3 6	1 4 6
14	0 13 6	0 15 3	0 17 0	1 5 6	1 6 6
15	0 15 0	0 17 0	0 19 0	1 6 6	1 8 0
16	0 16 6	0 18 6	1 0 0	1 8 0	1 9 0
17	0 18 0	1 0 0	1 1 0	1 10 0	2 0 0
18	1 0 0	1 2 0	1 2 0	1 12 0	2 1 0
19	1 1 6	1 4 0	1 3 6	1 14 0	2 2 0
20	1 3 0	1 5 6	1 5 0	1 16 0	2 3 0
21	1 4 6	1 7 0	1 6 6	1 18 0	2 4 0
22	1 6 0	1 8 6	1 8 0	2 0 0	2 5 0
23	1 7 6	2 0 0	2 0 0	2 2 0	2 6 0
24	1 9 0	2 1 6	2 1 6	2 4 0	2 7 0

LIST B.	Rough and Bastard.	2nd Cut.		Smooth.	Dead Smooth.
		Per Dozen.	Per Dozen.		
Inches. 1 to 4	£ s. d.	£ s. d.	£ s. d.	£ s. d.	£ s. d.
4	0 5 3	0 6 0	0 7 6	0 11 3	0 12 3
5	0 6 3	0 7 6	0 9 0	0 12 6	0 13 6
6	0 7 0	0 8 3	0 9 9	0 13 6	0 14 6
7	0 7 6	0 9 9	0 11 6	0 14 6	0 15 6
8	0 8 6	0 10 9	0 13 6	0 15 6	0 16 6
9	0 9 6	0 12 0	0 14 6	0 16 6	0 17 6
10	0 10 6	0 13 6	0 16 6	0 17 6	0 18 6
11	0 11 6	0 15 3	0 18 6	0 18 6	0 19 6
12	0 12 6	0 17 0	0 20 0	0 19 6	0 20 6
13	0 13 6	0 18 6	0 21 6	0 20 6	0 21 6
14	0 14 6	0 20 0	0 23 0	0 21 6	0 22 6
15	0 15 6	0 21 6	0 24 6	0 22 6	0 23 6
16	0 16 6	0 23 0	0 26 0	0 23 6	0 24 6
17	0 17 6	0 24 6	0 27 6	0 24 6	0 25 6
18	0 18 6	0 26 0	0 29 0	0 25 6	0 26 6
19	0 19 6	0 27 6	0 30 6	0 26 6	0 27 6
20	0 20 6	0 29 0	0 32 0	0 27 6	0 28 6
21	0 21 6	0 30 6	0 33 6	0 28 6	0 29 6
22	0 22 6	0 32 0	0 35 0	0 29 6	0 30 6
23	0 23 6	0 33 6	0 36 6	0 30 6	0 31 6
24	0 24 6	0 35 0	0 38 0	0 31 6	0 32 6

EXTRAS TO LIST A.

All above 24 inches, 20/- per inch extra. Flat Files, Double Cut on the Edge, to advance half inch. Topping Square Cut Edges, advance ½ inch. Mill Saw, 2 Round Edges, advance ½ inch. Feather Edge and Knife Files, to advance 3 inches.

EXTRAS TO LIST B.

All above 24 inches, 20/- per inch extra. Pin Files and Tanged Horse Rasps, to advance 1 inch. Round off with points, to advance 1 inch. Needle exceeding breadth of Hand Files, as equalling cut on both Edges. Equalling and Cotter Files, extra thin, to advance 1 inch.

Hand and Equalling Cut both Edges, or with one Double Cut Edge. Lock, Arch, Riffler, Tumbler, Oval Saw Files, Cant, Taper Cross, Bellied Three Square. Double Tanged Mill Saw, Topping, two Round Edges as List C.

LIST C.	Rough and Bastard.	2nd Cut.		Smooth.	Dead Smooth.
		Per Dozen.	Per Dozen.		
Inches 1 to 4	£ s. d.	£ s. d.	£ s. d.	£ s. d.	£ s. d.
4	0 6 8	0 7 6	0 9 0	0 13 6	0 14 6
5	0 7 0	0 8 3	0 9 6	0 14 6	0 15 9
6	0 7 6	0 8 9	0 10 6	0 15 9	0 16 6
7	0 8 6	0 9 9	0 11 6	0 17 6	0 18 6
8	0 9 6	0 10 9	0 12 3	0 18 6	0 19 6
9	0 10 6	0 12 0	0 13 6	1 0 0	1 1 0
10	0 11 0	0 12 9	0 14 6	1 2 0	1 3 0
11	0 12 0	0 13 6	0 15 6	1 3 6	1 4 6
12	0 13 6	0 15 3	0 17 0	1 5 6	1 6 6
13	0 15 0	0 17 0	0 19 0	1 6 6	1 8 0
14	0 16 6	0 18 6	1 0 0	1 8 0	1 9 0
15	0 18 0	1 0 0	1 1 0	1 10 0	2 0 0
16	1 0 0	1 2 0	1 2 0	1 12 0	2 1 0
17	1 1 6	1 4 0	1 3 6	1 14 0	2 2 0
18	1 3 0	1 5 6	1 5 0	1 16 0	2 3 0
19	1 4 6	1 7 0	1 6 6	1 18 0	2 4 0
20	1 6 0	1 8 6	1 8 0	2 0 0	2 5 0
21	1 7 6	2 0 0	2 0 0	2 2 0	2 6 0
22	1 9 0	2 1 6	2 1 6	2 4 0	2 7 0

LIST C.	Rough and Bastard.	2nd Cut.		Smooth.	Dead Smooth.
		Per Dozen.	Per Dozen.		
Inches 1 to 4	£ s. d.	£ s. d.	£ s. d.	£ s. d.	£ s. d.
11	1 5 0	1 7 0	1 10 0	2 5 0	2 6 0
12	1 7 0	1 10 0	1 13 0	2 7 0	2 8 0
13	1 10 0	1 13 0	1 16 0	2 9 0	3 0 0
14	1 12 0	1 16 0	1 19 0	3 1 0	3 2 0
15	1 19 0	2 3 0	2 6 0	3 3 0	3 4 0
16	2 6 0	2 11 0	2 18 0	3 5 0	3 6 0
17	2 15 0	3 0 0	3 7 0	3 7 0	3 8 0
18	3 4 0	3 10 0	3 19 0	3 9 0	4 0 0
19	3 14 0	4 2 0	4 11 0	4 1 0	4 2 0
20	4 7 0	4 15 0	5 5 0	4 3 0	4 4 0
21	5 0 0	5 8 0	6 0 0	4 5 0	4 6 0
22	5 14 0	6 3 0	6 15 0	4 7 0	4 8 0
23	6 11 0	7 1 0	7 16 0	4 9 0	5 0 0
24	7 10 0	8 1 0	8 2 0	5 1 0	5 2 0
	8 8 0	9 2 0	10 8 0	5 3 0	5 4 0

EXTRAS TO LIST C.

All above 24 inches, 20/- per inch extra. Hand and Equalling with Round Edges, advance 1 inch; if Double Cut, 2 inches. Two-tanged Mill Saw, 2 Round Edges, advance ½ inch.

PRICES OF FILES AND RASPS—Continued.

TAPER SAW FILES.				FRAME SAW FILES & GULLETING.		Blunt Segment Saw Files and Taper Cut to Point.	Blunt 2nd Cut Double and Bandsaw 2nd Cut Single.
	2nd Cut Single.	2nd Cut Double.	Smooth Single.	2nd Cut Single.	2nd Cut Double.	2nd Cut Single.	
Inches.	Per Doz. £ s. d.	Per Doz. £ s. d.	Per Doz. £ s. d.	Per Doz. £ s. d.	Per Doz. £ s. d.	Per Doz. £ s. d.	Per Doz. £ s. d.
1 to 3½	0 4 0	0 4 9	0 5 6	0 4 9	0 5 9	0 5 0	0 6 6
4	0 4 6	0 5 3	0 6 0	0 5 3	0 6 3	0 5 6	0 7 6
4½	0 5 0	0 6 0	0 6 3	0 5 9	0 6 9	0 6 6	0 8 6
5	0 5 6	0 6 6	0 7 0	0 6 6	0 7 6	0 7 6	0 9 6
5½	0 6 6	0 7 6	0 8 0	0 7 6	0 8 6	0 8 6	0 10 6
6	0 7 6	0 8 6	0 9 0	0 8 6	0 9 6	0 9 6	0 12 0
6½	0 8 6	0 9 6	0 10 0	0 9 6	0 10 6	0 10 6	0 13 6
7	0 9 6	0 11 0	0 11 0	0 10 6	0 12 0	0 12 0	0 15 6
7½	0 10 6	0 12 0	0 12 6	0 12 0	0 13 0	0 13 6	0 17 6
8	0 12 0	0 13 6	0 14 0	0 13 6	0 14 6	0 15 6	0 19 6
8½	0 13 6	0 15 0	0 15 6	0 14 6	0 16 0	0 17 6	1 1 6
9	0 15 6	0 17 0	0 17 0	0 16 0	0 17 6	0 19 6	1 4 0
9½	0 17 6	0 19 6	0 19 6	0 18 0	0 19 6	1 1 6	1 6 6
10	0 19 6	1 1 0	1 1 0	1 0 0	1 2 0	1 4 0	1 9 0
11	1 4 0	1 6 0	1 6 0	1 5 0	1 7 0	1 9 0	1 14 0
12	1 9 0	1 11 0	1 11 0	1 10 0	1 12 0	1 14 0	2 0 0
13	1 14 0	1 17 0	1 17 0	1 16 0	1 19 0	2 0 0	..
14	2 0 0	2 3 0	2 3 0	2 3 0	2 6 0

Inch.	PLAIN & SWAGED.		KNIFE SHAPE.		CANT SHAPE.	
	SINGLE.	DOUBLE.	SINGLE.	DOUBLE.	SINGLE.	DOUBLE.
	Per Doz. £ s. d.	Per Doz. £ s. d.	Per Doz. £ s. d.	Per Doz. £ s. d.	Per Doz. £ s. d.	Per Doz. £ s. d.
7	0 8 6	0 9 0	0 8 6	0 9 6	0 12 6	0 13 6
8	0 9 3	0 10 0	0 9 6	0 10 6	0 13 6	0 14 9
9	0 11 6	0 12 9	0 11 9	0 13 3	0 16 3	0 17 6
10	0 13 6	0 15 6	0 13 9	0 16 0	0 19 0	1 1 3

Taper saw files, double cut smooth, to advance half-inch, on single smooth. Frame equalling saw files, 3 inches on the frame saw price.

EXTRAS.

Rubbers, rough and bastard	1/3 per lb.
Do. second cut	1/5 "
Do. smooth	1/7 "
	ROUGH AND BASTARD.		2ND CUT.		SMOOTH.	
1 lb rubber	..	1/8 per lb.	..	1/9 per lb.	..	1/10 per lb.
2 lb. do.	..	1/5 "	..	1/6 "	..	1/7 "
3 lb. do.	..	1/4 "	..	1/5 "	..	1/6 "
Strong flat files, and half-thicks, rough and bastard	1/5 "
Do. do. second cut	1/7 "
Do. do. smooth	1/9 "

Three-square id. per lb. extra to flat files.

Horse mouth rasps, 5/- each. Bread rasps, handled, 30/- per doz. Single improved shoe rasps, ½ in. on flat prices. Double improved shoe rasps, 1 in. on flat prices. Last makers' rasps, to advance 2 in. Saddle tree rasps, to advance 3 in. All parallel files to advance 1 in. on their respective descriptions. All ½ in. the price of the next size above. Round, half-round, and cross files, double cut second cut to advance ½ in. Do. double cut smooth, to advance 1 in. Flat, three-square, and hand files, rough and middle cut, above 1 ¼ in., 6d. per dozen extra to bastard cut. New cut files to advance 1 in.

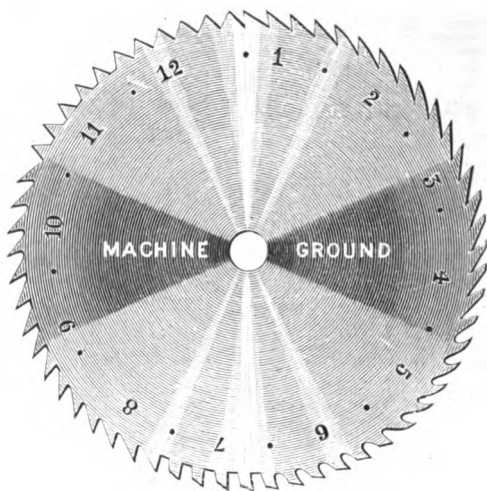

Fig. 3147.

PRICES OF CAST STEEL CIRCULAR SAWS, Fig. 3147.

4	4½	4	6	7	8	9	10	12	14	16	18	20	22	24	26	28	inch
4/6	5/-	6/-	7/-	8/-	9/6	11/-	13/-	16/-	20/-	24/-	40/-	36/-	42/-	48/-	56/-	66/-	each
								17	17t	16	15	14	14t	13	13	12	gauge
30	32	34	36	38	40	42	44	46	48	50	52	54	56	58	60	inch	
76/	88/	104/	120/	145/	160/	180/	215/	240/	270/	380/	420/	480/	570/	620/	680/	each	
12	12	12t	11	11	11t	10e	10	9e	9	8e	8	7	6	5e	5	gauge	

Circular saws stronger than the gauges named, the price advances proportionately.

CAST STEEL CIRCULAR SAWS for sawing iron and steel and
CAST STEEL CIRCULAR SAWS for sawing slate. Prices on application.

PRICES OF CAST STEEL GROOVING SAWS.

The teeth are sawn out, and the saw turned thinner to the centre.

½	⅝	¾	⅞	8	⅞	1	1⅛	1⅜	1½	1⅝	1⅞	2	2⅛	2¼	2½	2⅝	2¾	3	3⅛	3¼	3½	3¾	4	4½	5	5½	6	6½	7	7½	8	8½	9	9½	10	inch thick
1/6	1/10	2/-	2/2	2/5	2/7	2/9	3/-	3/2	3/5	3/7	3/10	4/8	per inch diam.																							

PRICES OF MILL SAWS.

		7½	8	8	8½	8½	9	9½	in. wide
		5	5½	6	6½	7	7½	8	8 feet
Cast steel ...		26/-	28/-	30/-	33/-	37/-	42/-	48/-	each
German steel		22/-	24/-	26/-	29/-	33/-	38/-	44/-	"

Cast steel mill saws, hardened and tempered, stronger than the 10 gauge, to 5½ft., charged 2/-; above 5½ft., 3/- per gauge extra, gross.

Mill saws stronger than the 8 gauge, not hardened and tempered, to 5½ft., charged 2/-; and above 5½ft., 3/- per gauge extra.

PRICES OF PIT AND FRAME SAWS.

	4	4½	5	5½	6	6½	7	7½	8	8½	9	9½	10	feet
German steel	15/-	16/-	18/-	19/6	22/-	24/-	26/-	30/-	36/-	46/-	58/-	66/-	76/-	each
Cast steel ..	16/6	17/6	19/6	21/-	24/-	26/-	28/-	33/-	39/-	49/-	61/-	70/-	80/-	"
London spring	19/-	21/-	23/-	26/-	29/-	32/-	35/-	40/-	46/-	56/-	68/-	76/-	86/-	"

If exceeding 11in. heel, to advance 3/- per inch extra.

PRICES OF BEST WOOD FRAMES FOR ABOVE.

Sizes	5½	6	6½	7	7½	8	feet
Price	13/6	14/6	15/6	16/6	17/6	18/6	each

PRICES OF PERIN'S PATENT FRENCH BAND SAWS.

Length .. feet	12	13	14	15	16	17	18	19	20	21	22	23	24
Width, $\frac{1}{8}$, $\frac{1}{4}$, $\frac{3}{8}$ in.	5/8	6/3	6/9	7/3	7/9	8/3	9/-	9/9	10/3	10/9	11/3	11/9	12/3
Do. $\frac{1}{4}$ in.	6/-	6/9	7/3	7/9	8/3	9/-	9/9	10/3	10/9	11/3	11/9	12/3	12/9
Do. $\frac{3}{8}$ in.	6/9	7/6	8/-	8/6	9/-	9/9	10/3	11/-	11/6	12/3	12/6	13/-	13/9
Do. $\frac{1}{2}$ in.	7/3	8/-	8/3	9/-	9/9	10/3	11/-	11/9	12/3	12/9	13/6	14/-	14/9
Do. $\frac{5}{8}$ in.	8/-	8/3	9/-	9/9	10/3	11/-	11/9	12/3	12/9	13/6	14/3	14/9	15/6
Do. $\frac{3}{4}$ in.	8/3	9/-	9/9	10/3	11/-	11/9	12/3	12/9	13/6	14/3	15/-	15/6	16/3
Do. 1 in.	9/-	9/9	10/3	11/-	11/9	12/6	13/-	13/9	14/6	15/3	15/9	16/6	17/-
Do. $1\frac{1}{4}$ in.	10/-	10/9	11/9	12/6	13/3	14/3	15/3	15/9	16/9	17/6	18/6	19/6	20/3
Do. $1\frac{1}{2}$ in.	11/9	12/6	13/6	14/6	15/6	16/6	17/6	18/6	19/6	20/3	21/6	22/3	23/3
Width 2in. of any length up to 50ft. 1/5 per ft.							Width, 3in. of any length up to 50ft. 2/3 per ft.						
Do. $2\frac{1}{2}$ in. do. do. do. 1/10 ,,							Do. 4in. do. do. 3/5 ,,						

PRICES OF FRET SAWS.

Length	9 inches	12 inches	14 inches
Price per dozen	6/6	7/6	9/6

PRICES OF BILLET, CANADA, OR WOODCUTTERS' WEBS.

	28	30	32	34	36	39	42	45	48	51	54	57	60 inch
Cast steel..	35/-	39/-	44/-	46/-	54/-	61/-	66/-	79/-	103/-	109/-	113/-	123/-	140/- doz.
German do.	31/-	35/-	40/-	42/-	50/-	55/-	60/-	73/-	94/-	100/-	104/-	114/-	130/- ,,

Setting and sharpening to 28in., 6/-; above 28 to 34in., 6/6 doz. extra, gross.

PRICES OF CROSS CUT SAWS.

	4	4½	5	5½	6	6½	7	7½	8	8½	9	9½	10 feet
German steel..	12/-	14/-	17/-	18/-	20/-	22/-	24/-	28/-	36/-	42/-	50/-	58/-	68/- each
Cast steel ..	13/-	15/-	18/-	19/-	22/-	24/-	26/-	31/-	39/-	45/-	54/-	62/-	72/- ,,
London spring	14/-	16/-	19/-	20/-	24/-	26/-	28/-	34/-	42/-	48/-	58/-	66/-	76/- ,,

PRICES OF HAND SAWS.

	10	12	14	16	18	20	22	24	26	28	30 inch
German steel ..	24/-	28/-	30/-	40/-	46/-	50/-	56/-	62/-	64/-	70/-	76/- doz.
Cast steel ..	28/-	34/-	42/-	48/-	54/-	58/-	64/-	72/-	74/-	80/-	86/- ,,
London spring steel	32/-	38/-	46/-	54/-	60/-	66/-	74/-	84/-	90/-	96/-	108/- ,,

Mahogany handles, 8/- doz. extra; French polished handles, 8/- doz. extra; Polished plates, to 26in. 54/-; to 28in. 66/-; 30in. 76/- doz. extra. Fine tooth saws, 10 to 12 points, 2/-; above 12 points, 3/- extra gross.

IRON AND BRASS BACK SAWS.

	10	12	14	16	18	20	22	24	inch
German steel, iron backs	48/-	52/-	56/-	62/-	66/-	68/-	86/-	110/-	doz.
Do. do. blue do.	50/-	54/-	58/-	64/-	68/-	70/-	88/-	112/-	,,
Cast steel, blued do.	56/-	60/-	64/-	72/-	76/-	78/-	96/-	120/-	,,
Warranted London spring, blued	64/-	68/-	72/-	82/-	86/-	88/-	106/-	130/-	,,
Cast steel, brass backs ..	72/-	80/-	90/-	104/-	112/-	118/-	144/-	175/-	,,
Warranted London Spring, brass	84/-	96/-	108/-	120/-	132/-	144/-	180/-	225/-	,,

Polished plates and backs, to 20in., 36/-, above 20in., 54/- doz. extra; Mahogany handles to 12in. 4/-, above 12in., 6/- doz. extra; French polished handles, to 12in., 6/-, above 12in., 8/- doz. extra.

CAST STEEL COMPASS OR LOCK SAWS.

	10	12	14	16	18	20 inch
	20/-	21/-	22/-	24/-	26/-	28/- doz.

PRICES OF AUGERS AND BRACE BITS.

Size in.	$\frac{3}{8}$	$\frac{7}{16}$	$\frac{1}{2}$	$\frac{9}{16}$	$\frac{5}{8}$	$1\frac{1}{8}$	$1\frac{3}{8}$	$1\frac{5}{8}$	$1\frac{7}{8}$	2	$2\frac{1}{8}$	$2\frac{1}{4}$	$2\frac{1}{2}$	$2\frac{3}{4}$	3
Bolt and trenail augers per doz.	9/-	9/-	9/-	10/6	10/6	13/6	13/6	15/-	15/-	17/-	17/-	17/-	17/-	17/-	17/-
American single twist trenail augers	2/5	2/8	2/11	3/3	3/6	3/9	4/1	4/3	4/3	4/3	4/3	4/3
Carpenter's tanged shell augers ea.	8d.	..	10d.	..	1/-	..	1/2	..	1/4	..	1/4	..	1/4
Eyed shell augers	1/2	..	1/4	..	1/6	..	1/9	..	2/-	..	2/-	..	2/-
Long bright eyed Scotch screw do.	2/-	..	2/3	..	2/6	..	2/10	..	3/3	..	3/3	..	3/3
Gedge's Patent tanged screw do.	1/8	1/8	1/8	1/10	1/11	2/-	2/1	2/2	2/5	..	2/5	..	2/5
Size in.	$1\frac{1}{2}$	$1\frac{3}{8}$	$1\frac{1}{4}$	$1\frac{5}{8}$	$1\frac{3}{4}$	$1\frac{7}{8}$	$1\frac{1}{2}$	$1\frac{5}{8}$	$1\frac{3}{4}$	$1\frac{7}{8}$	2	$2\frac{1}{8}$	$2\frac{1}{4}$	$2\frac{3}{4}$	3
Bolt and trenail augers per doz.	18/6	..	23/-	..	25/-	..	30/-
American single twist trenail augers	4/6	5/3	5/6	5/9	6/4	6/7	6/10
Carpenter's tanged shell augers ea.	1/6	..	1/8	..	1/10	..	2/3	2/6	2/9	3/3	3/6	3/6	3/6	3/6	3/6
Eyed shell augers	2/3	..	2/6	..	2/9	..	3/-	..	4/-	..	4/6	..	4/6	..	4/6
Long bright eyed Scotch screw do.	3/9	..	4/3	..	4/6	..	5/-	5/6	6/-	6/6	7/-	7/-	7/-	7/-	7/-
Gedge's patent tanged screw do.	2/9	3/2	3/2	..	3/4	..	3/10	4/4	4/10	5/5	6/-	6/-	6/-	6/-	6/-
Centre bits from $\frac{1}{8}$ in. to 3 in.	4 $\frac{1}{2}$ d.	to 4/6 each.
Shell	4 $\frac{1}{2}$ d.	to 1/3
Nose	4 $\frac{1}{2}$ d.	to 1/3
Spoon	5d.	to 1/6
Complete set of 36 bits, black 15/- bright 17/- per set.															

PRICES OF CARPENTERS' AND JOINERS' TOOLS.

Best wood braces	9/- each.					
Scotch wrought iron braces	14/- ..					
Malleable iron braces	6/6 ..					
Black bits	from 4 $\frac{1}{2}$ d. ..					
Joiners' chisels, handled	7/6 per set.					
Joiners' gouges, handled	8/9 ..					
Mortice chisels, handled	14/6 ..					
Axes	1/- per lb.					
Carpenters' Adzes	1 2 3 4 inch.					
Boxes and taps for cutting wood screws	$\frac{3}{8}$	$\frac{1}{2}$	$\frac{5}{8}$	$\frac{3}{4}$	$\frac{7}{8}$	1	$1\frac{1}{8}$	$1\frac{1}{4}$	$1\frac{1}{2}$	$1\frac{3}{4}$	2	$2\frac{1}{4}$	$2\frac{1}{2}$	inch.
Best shell gimlets	3/6 per doz.					
Best twisted gimlets	4/6 ..					
Wing compasses	from 1/7 each					
Millwrights' compasses	4/- to 5/- ..					
Best joiners' squares	3	4 $\frac{1}{2}$	6	7 $\frac{1}{2}$	9	12	15	18	inch.				
Plated squares	1/10	2/-	2/6	3/-	3/6	4/6	6/6	7/6	each.				
Spokeshaves beech	1/-	1/2	1/4	1/6	2/-	..	each.				
Do. box	1/6	1/9	2/-	2/6				
Carpenters' saw sets	8d.	1/-	1/6				
Patent do.	5/-				
Screwdrivers	6d. to 3/-				
Gedge's screw bits	$\frac{1}{2}$	$\frac{9}{16}$	$\frac{5}{8}$	$\frac{3}{4}$	$\frac{7}{8}$	1	$1\frac{1}{8}$	$1\frac{1}{4}$	inch.				
Spring dividers	1/5	1/6	1/7	1/8	1/10	1/11	2/2	2/7	each.				
Hand screws	2/4 to 4/3				
Bench screws	10d. to 2/-				
Do. iron	1/9 to 2/-				
..	12/6				

PRICES OF JOINERS' AND CARPENTERS' TOOLS—Continued.

Glass paper	9d.	per quire.
Scrapers	6d.	each.
Carpenters' pincers	1/- to 3/-	„
Spirit levels, single plated	6 7 8 9 10 12	inch.
										2/6 2/9 3/6 3/6 4/- 5/-	each.
Spirit levels, double plated	6 7 8 9 10 12 14 16 18	inch.
										4/- 4/3 4/6 5/- 5/6 6/6 8/6 9/6 10/6	each.
Pocket levels, double plated, 12 inches	2/6	„
Mitre squares	4/6	„
Washita oilstones	1/9	per lb.
Charley Forest do.	10d.	„
Tape measures	1/- to 12/-	each.
Joiners' cramps	10/- to 25/-	„
Do. patent	16/- to 37/-	„
Floor dogs	21/- to 30/-	per pair.

ENGINEERS' STORES.—The articles used in different branches of construction vary so widely that—from mere lack of space—some will not be enumerated in the various sections of this book or in the subjoined schedule of approximate prices. Reference is however made to the stores in general demand but (although prices fluctuate to some extent) those given will serve as a basis for estimates.

Steel Wire to 20 W.G. 8d. per lb.

Brass Wire „ „ 8½d. „

Copper Wire „ „ 10d. „

Iron Wire „ „ 3d. „

Sheet Lead up to ⅜ in. thick 16/6 per cwt. Lead Wire 8d. per lb.

Sheet Copper up to ½ in. thick, 75/- per cwt.

Copper Wire gauze 50 mesh 3d. per lb.

Ingot Metal for bearings :—

Brass 1/- per lb. Phosphor Bronze 1/3 per lb.

Magnolia Metal 1/4 per lb. Anti-friction (Babbitt's) Metal 8d. to 1/3 per lb.

Sheet India Rubber 7/6 per lb. India Rubber Washers 1/3 to 7/6 per lb.

Sheet Asbestos 3/6 to 6/- per lb. Asbestos Washers 2/- to 9/- per lb.

Spun Yarn 40/- per cwt. Tarred Yarn 36/- per cwt.

Coloured Waste 27/- per cwt. Best White Cotton Waste 34/- per cwt.

White Lead about 23/- per cwt. Red Lead 17/- per cwt. Tallow 32/- per cwt.

Oils, &c. in metallic kegs, approximate prices :—

Lard Oil 4/4, Linseed Oil. 2/8, Turpentine 2/8 per gallon.

Muriatic Acid 3d. per lb. Borax 6d. per lb.

Cyanide of Potassium from 2/8 to 3/- per lb.

Spelter 3d. per lb. Solder 8d. per lb. Copper Soldering Bits 1/4 per lb.

Best Hide Leather 2/- per lb.

Emery 28/- per cwt. Emery Cloth 56/- per ream.

CUPOLAS, FURNACES, AND SMITHS' TOOLS.

FOUNDRY CUPOLAS.—Of the four types referred to in the following remarks, that indicated as type **A** (not illustrated) is unquestionably the most perfect in construction and fairly entitles the patentee to claim for it, great purity in the quality of metal and economy in the quantity brought down by a given weight of fuel.

The Cupolas **B** and **C** come next in order of perfection, whilst type **D**—which is not surrounded by an air belt and has a single tuyere—answers every purpose where the work is intermittent and economy in the consumption of fuel is, relatively of small importance.

As regards construction, the shells, in each type are built of wrought iron plates and rivetted together, the heads being flat on the inside so as not to interfere with the fire brick lining.

The approximate output of metals stated in tons per hour. The prices—as well as all the rest in the book—are subject to fluctuations in the prices of materials and labour.

THE CUPOLA TYPE

A is surrounded by an air belt through which the blast from the tuyeres is distributed to all parts of the circumference of the furnace.

In lieu of the deep hearth commonly used, the cupola has a receiver into which the metal flows from the furnace and has capacity for storing the product of half-an-hours melting.

The cupola is provided with drop bottoms for instantly clearing it and affording access for examination and repairs, the whole being supported by an entablature with cast iron columns and base plate.

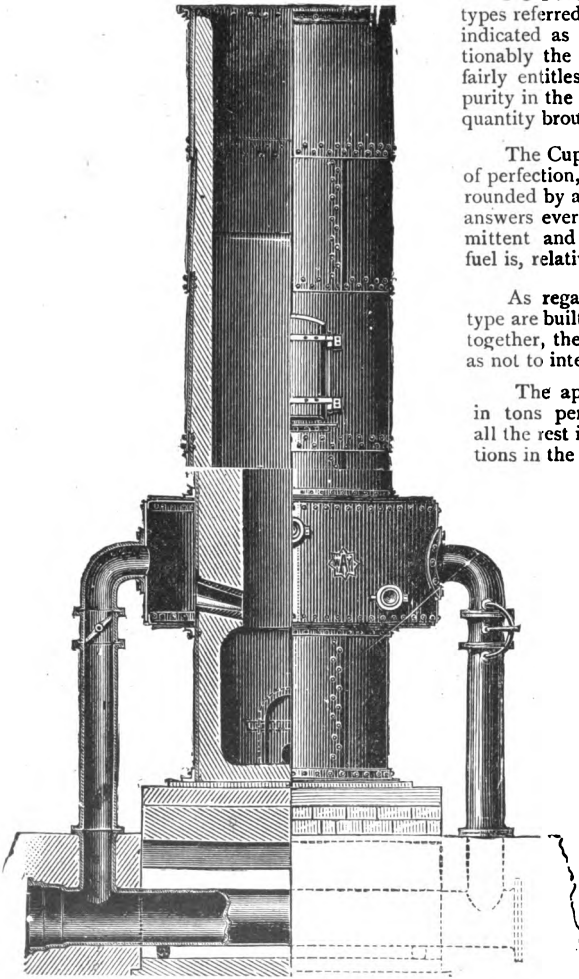

Fig. 3148.

CUPOLA TYPE B.—The blast pipes are connected with an annular air belt as shown in Fig. 3148, and is provided with drop bottoms and carried on columns as above described.

The tuyeres are fitted with sight holes and there is a door, for use in case of need, to clear the hearth or give access to the interior. The charging door is at a convenient height and inexpensive metal hoists can be supplied, if desired, to work by steam, hydraulic or manual power.

THE CUPOLA TYPE C, illustrated by Fig. 3148, is of the construction generally used and has a door for cleaning out, &c., but not a drop bottom.

The arrangements of the blast pipes, valves, air belt, &c., are as described above and shown in the engraving.

CUPOLAS OF THE TYPE D—like many which have been in regular and successful use for many years—are made without the air belt, and the blast is conveyed to the furnace by a single tuyere

PRICES OF CUPOLAS, TYPE A.

Capacity, tons melted per hour	1	2	4	6	8
Price of cupola	£60	£70	£115	£155	£195
Do. Root's blower	£31	£42	£60	£84	£96
H.P. to drive blower	2	4	6	8	8
Approximate weight tons	2½	2½	4½	7½	9½
Do. measurement cubic feet	125	210	360	670	930
Price of fire brick lining	£14	£16	£28	£40	£55
Approximate weight of do. tons	3½	4	8	13	16

The cost of packing for shipment and delivery f.o.b. varies from 3 to 5 per cent.

PRICES OF CUPOLAS, TYPE B.

Capacity, tons melted per hour	1	2	4	6	8
Price of cupola	£44 5	£51 5	£84 5	£120 10	£147
Do. Root's blower	£31	£42	£60	£84	£96
H.P. to drive blower	2	4	6	8	8
Approximate weight of cupola tons	2½	2½	4½	6½	7½
Price of fire brick lining	£11 15	£13 15	£20 15	£27 15	£35 15
Approximate weight tons	2½	3½	6	9½	12

The cost of packing &c. as above.

PRICES OF CUPOLAS, TYPE C.

Capacity, tons melted per hour	1	2	4	6	8
Price of cupola	£43	£50	£83	£115	£140
Do. Root's blower	£31	£42	£60	£84	£96
H.P. to drive blower	2	4	6	8	8
Approximate weight of cupola tons	1½	2½	3½	5½	7
Price of fire brick lining	£12 5	£16	£22	£29	£37
Approximate weight tons	2½	3½	6	9½	12

The cost of packing &c. same as for Type A.

PRICES OF CUPOLAS, TYPE D.

Capacity, tons melted per hour	½	1	2	4	5
Price of cupola	£32	£41 10	£52	£81 15	£105
Do. Root's blower	£25	£31	£42	£60	£69
H.P. to drive blower	½	2	4	6	6
Approximate weight of cupola tons	1	1½	1½	3	4
Price of fire brick lining	£9	£12 5	£16	£22	£25
Approximate weight of do.	1½	1½ 5	2½	5	6½

Cost of packing &c. same as for Type A.

CUPOLA HOISTS are usually constructed of wrought iron or steel of suitable sections, strongly braced and provided with top and bottom frames. The rising platform is made of wrought iron and fitted with steadying rollers in the corners.

In some cases, however, the frame work is built in timber by the purchasers, the machinery and ironwork only being sent out.

The frame is usually vertical but, if desired, it can be fixed at an angle and the rising table arranged for the barrow or truck to be run off to the charging platform.

These hoists are worked by steam, hydraulic or hand power as may be most convenient.

FOUNDRY LADLES.—Both types of the ladles referred to in the subjoined list of prices are made of wrought iron plates and the trunnions of the crane ladles are accurately fitted and adjusted for balance.

The advantages of the patent ladles, invented by Messrs. Goodwin and How, are that the speed of teeming can be easily and completely regulated and that the slag and impurities are retained in the ladle and cannot pass out into the casting. It is well known that metal is not always properly skimmed, even by experienced workmen, and it is estimated that immunity from wasters—even in only one large casting—more than compensates the extra cost of these appliances.

PRICES OF WROUGHT IRON CRANE LADLES.

Capacity of ladle	5	10	15	20
Price of crane ladle	£4 6 0	£5 18 0	£6 10 0	£6 17 6
Do. patent do.	£9 7 6	£12 0 0	£13 2 6	£13 15 0

The cost of packing for shipment and delivery f.o.b. varies but may be assumed to be about 5 per cent.

HAND LADLES are forged out of one plate of iron of superior quality and are guaranteed to be sound and well finished.

PRICES OF WROUGHT IRON HAND LADLES.

Capacity of ladle	30	40	56
Price of do.	£0 10 6	£0 12 6	£0 16 9

THE UNIVERSAL MELTING FURNACE, invented and patented by Mr. Piat, is invaluable for melting (in the same furnace, if desired,) brass, bronze, gunmetal, alloys of every kind, iron, steel, or malleable cast iron. The fact that more than 500 of these furnaces have been put up within the last four years, in some of the largest and best equipped works on the Continent of Europe and elsewhere, is sufficient evidence of their practical utility.

Amongst the advantages derived from the use of these furnaces may be mentioned :—

High efficiency and economy in fuel and in labour.

The production from the same furnace of castings, in any of the above-named metals, of excellent quality and great tensile strength.

That they can be used intermittently without appreciable increase in the cost of working.

The crucible is not taken out for each cast, so that neither the metal or the crucible are cooled by contact with the air, lifting tongs, &c.

The absence of danger from the crucible bursting whilst being handled.

Portability and the small space (usually about 3 ft. 6 in. by 10 ft.) which the furnace occupies.

Increase in strength of castings—10 to 20 per cent.

Decrease in waster castings—usually less than 2 per cent.

Some data relating to time for melting, consumption of fuel, &c., is given later on, but unfortunately space does not admit of giving full details in regard to the mode of working, output and many other facts, full information on these and other matters will, however, be gladly given by the Writer.

As the "Universal" furnace melts all metals commonly used and produces castings of exceptionally good quality. limited in quantity only by the number of furnaces employed, it is evident that they may be used with advantage, continuously in large establishments, or intermittently in smaller ones, where it would be out of the question to have a foundry of the usual type for each kind of metal required, or perhaps for any of them.

This remark applies equally to many factories which are remote from well equipped foundries and, where the loss of time involved in replacing one broken part in metal of suitable quality, causes a pecuniary loss far exceeding the whole cost of the furnace.

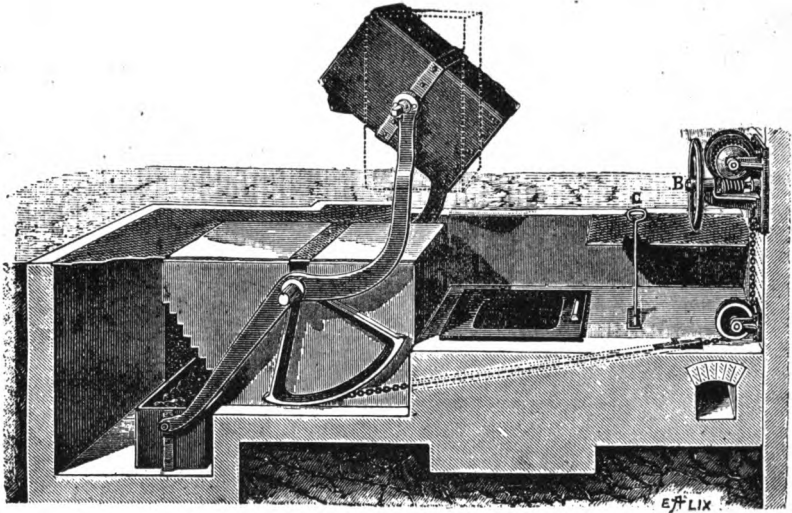

Fig. 3149.

FURNACES FOR MELTING BRASS, BRONZE, &c. are constructed as shown in Fig. 3149 and consist of a rectangular box made of steel plates and lined with fire bricks. The external steel band, with trunnions on opposite sides, is adjusted to the height which admits of the furnace being easily turned and controlled by a hand lever, when suspended on the quadrant arms in position for teeming the molten metal. The bottom of the furnace is provided with steel fire bars which support the fire brick stool and crucible, this being held in position by a fire brick lip and wedge piece on opposite sides.

When in position for melting, the furnace rests over the rectangular hole in the base plate below which the blast is admitted at a pressure equal to 6 to 8 inches column of water, and is regulated or shut off by the damper C, Fig. 3149. The blast having been shut off and the metal skimmed, the furnace is raised by the arms, quadrant piece, and winch B, and turned over to the position required for teeming the metal into the previously heated ladles.

As soon as the cast has been teemed, the hauling chain is slacked out from the winch until the furnace again rests on its base plate, when everything is ready for the next charge.

It will be seen on reference to the engravings, that the mode of working is extremely safe and simple and that, the blast being admitted through the grate bars, the metal at the bottom of the crucible must always be the hottest.

This is contrary to what takes place in the ordinary furnaces and is a feature of considerable practical value because, as is well known to brass founders, there is a sensible loss of zinc and some other alloys, when certain temperatures are exceeded and that this has to be reduced—just when it ought not to be—by the addition of an old runner or other piece of solid metal.

The materials included in the following prices comprise, the furnace constructed of steel plates with strengthening band and trunnions, fire brick lining with lip, wedge piece and stool, plumbago crucible and cover, furnace base plate and damper, two lifting levers with bearings for trunnions, cross shaft and bearings, quadrant piece and chain, chain guide sheave and bracket, winch for lifting the furnace, box for counter weight to balance the furnace, poker and tongs.

PRICES OF FURNACES TO MELT BRASS, BRONZE, &c., Fig. 3149.

Capacity of crucible lbs.	220	330	670
Price of furnace	£60	£68	£73

The cost of packing for shipment and delivery f.o.b. is 5 per cent.

THE INTENSIFIER.—This valuable improvement, also patented by Mr. Piat, was invented with a view to reduce the quantity of coke as well as the time required to melt brass, copper and its alloys, and to add materially to the life of the crucible. All these conditions have been completely fulfilled.

It is now made in two parts and rests on the top of the furnace, over the crucible, during melting time. The lower part is perforated with holes of suitable size and shape and the metal to be melted is charged into the intensifier, not into the crucible. The blast, which has been heated in passing through the furnace is directed through the holes above referred to, and causes the flame to impinge on the metal after the manner of a blow pipe. The effect of this is that the metal is brought into complete fusion much more rapidly than by any other method of melting, and falls into the crucible for teeming in the manner already described.

There is no deterioration in quality and, until they saw it, many founders have been unable to believe that gun metal, bronze, and brass castings of the highest quality and weighing 200 to 300 lbs. or more, could be produced in about 20 minutes with a consumption of coke of less than 14 per cent of the weight of castings.

In further illustration of the rapidity with which the universal melting furnace with intensifier, brings the metal into fusion, it may be mentioned that two furnaces, each having a capacity of 3 to 4 cwt. (150 to 200 kilos.) have turned out perfect castings weighing 12 cwt. (600 kilos.), the metal not having time to cool between the consecutive turnings.

PRICES OF FURNACES, Fig. 3149, WITH INTENSIFIERS.

Capacity of furnace lbs.	220	330	670
Price of furnace and intensifier	£80	£88	£93
Do. bottom for intensifier	£1 0 0	£1 5 0	£1 10 0
Do. tops do.	£1 5 0	£1 10 0	£1 15 0

The cost of packing for shipment and delivery f.o.b. costs 6 per cent.

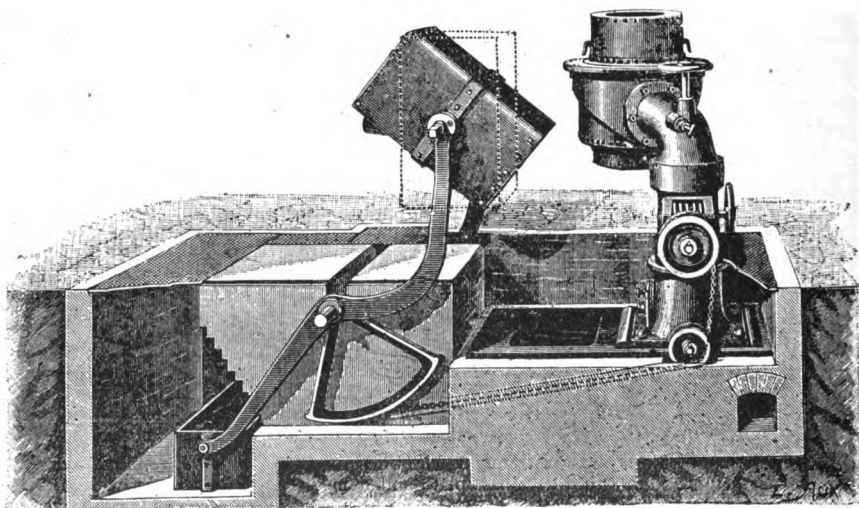

Fig. 3152.

THE UNIVERSAL FURNACE TO MELT IRON, STEEL, MALLEABLE IRON, &c., as shown in Fig. 3152, is adapted for melting any or all of the above-named metals, or any desired alloys, and to produce castings of greater density and tensile strength than can be obtained by any other system of melting.

The furnace is precisely similar to Fig. 3149 and, with the following additions, the same description applies to this arrangement.

The additions consist of the cupola which is supported by the column with swivelling head as shown in Fig. 3152. The winch gear and valves for regulating the blast, as will be seen, are carried in the column.

The cupola is constructed in the usual way and is surrounded by an air belt with apertures which admit the blast, but the metal is not allowed to remain in the bosh as will be shortly described.

The charge consists of the usual alternate layers of coke and metal and, when the bottom of the cupola has been brought over the centre of the furnace, the blast (equal to 6 to 8 inches water column) is admitted simultaneously to the cupola and the furnace, so that the crucible may be at the proper heat to receive the metal.

An aperture in the bottom of the cupola allows the metal to fall into the crucible as quickly as it is melted, and so avoids the deterioration in quality which is imparted by contact with coke in combustion.

For making common castings the cupola may be turned to one side and the metal run direct into the foundry ladle and, when in this position, the furnace is available for melting brass or gun metal.

STEEL OR MALLEABLE IRON CASTINGS.—A further advantage derived from this system of melting is, that the temperature of the metal is so easily maintained at the degree requisite to give it complete fluidity; the result is that the strength of the metal, melted by this process, exceeds that produced from similar metal melted in the ordinary way, by 10 to 20 per cent, with far smaller proportion of waste castings and lower cost of production.

One furnace of the larger size easily gives 5 or 6 cwt. (250 to 300 kilos.) of castings per hour and the weight of single castings or the total output in a given time is limited only by the number and size of furnaces employed.

If the metal is run from the cupola into the ladle the wear and tear of crucibles and the cost of the coke for the furnace are saved, and the consumption of fuel is only about 16 per cent. of the weight of metal melted, but when melting steel or malleable iron the consumption is of course larger.

The materials included in the following prices comprise the wrought iron cupola with air belt and fire brick lining, the cast iron column with swivelling head and base plate and complete with valves for regulating the admission of blast, worm and wheel winch with chain barrel, chain, chain sheave, and sector. Also the steel furnace casing with strengthening band and trunnions, fire brick lining, lip, wedge piece and stool, plumbago crucible and cover, furnace plate and damper, two lifting levers with bearings for trunnions, cross shaft and bearings, box for counterweight to balance furnace, &c.

PRICES OF FURNACES TO MELT IRON, STEEL, &c, Fig. 3152.

Capacity of furnace cwt.	2	3	6
Price of furnace	£98	£110	£120

The cost of packing for shipment and delivery f.o.b is 5 per cent.

TESTS WITH FURNACE AND INTENSIFIER.—The tests referred to below were made with a uniform charge of 74 lbs. of bronze and the average shows that the consumption of coke is equivalent to about 16 per cent. of the weight of metal melted, the average time occupied in charging and melting each cast being 25 minutes.

No of test	1	2	3	4	5	6	7	8
Consumption coke .. lbs.	25½	16½	12½	11	10	17½	7	7
Time occupied .. minutes	38	27	25	21	22	28	26	23

Following these tests, 56 lbs. of phosphor bronze was melted in 14 minutes and the consumption of coke was 7 lbs.

FURNACE FOR MELTING GOLD, SILVER, &c.—The construction of furnaces for dealing with the precious metals, is similar to that shown in Fig. 3149, but some modifications are made in the form of the crucible and in the appliances for teeming, specially adapted for minting and similar purposes.

CARR'S CRUCIBLE MELTING FURNACE, not illustrated, consists of a rectangular casing of wrought or cast iron, mounted on feet and provided with an improved form of grate bars and bearers, are made to carry one or two crucibles.

PRICES OF CARR'S CRUCIBLE FURNACES FOR BRASS, &c.

Capacity of crucible .. lbs.	30	50	70	100	120
Price of single furnace ..	£7 17 6	£8 8 0	£10	£12	£13
Do. double do. ..	£13	£14	£16 15 0	£20 5 0	£21 15 0
Space occupied .. inches	24 by 40	25 by 46	24 by 48	27 by 50	29 by 51

PRICES OF FURNACES FOR MALLEABLE OR COMMON IRON.

Capacity of crucible .. lbs.	40	60	80	100	120
Price of single furnace ..	£9 10 0	£11	£12	£13	£15
Do. double do. ..	£15 15 0	£18 5 0	£20 5 0	£21 15 0	£25
Space occupied .. inches	28 by 49	29 by 53	30 by 55	31 by 57	32 by 57

The cost of packing for shipment and delivery f.o.b. averages about $7\frac{1}{2}$ per cent.

Foundry Accessories such as **Moulding Tools, Sieves, Rammers, Moulding Boxes**, fitted or unfitted, **Crucibles, Tongs, &c.**, also **Fire Bricks and Specials, Fire Clay, &c.**, for furnace linings, will be supplied to specification and special quotation.

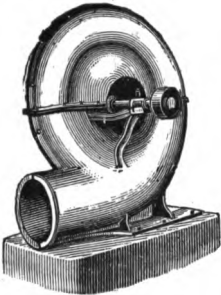

Fig. 3153.

BLAST FANS of the type Fig. 3153, originally designed for supplying the strong and continuous current of air required for melting metals in cupolas, for smiths' hearths, &c., are now, to some extent superseded for those purposes by blowers of the type referred to later on.

They are however largely used where a steady supply of cold or hot air is required for drying wool, yarns, textile fabrics, grain, vegetable matter, &c.; also for forcing fresh air into mines, shafts, wells, tunnels, and for ventilation generally, see Mining Machinery, Section VI.

All these fans will deliver or exhaust the volume of air mentioned in the subjoined lists and the data, as regards the number of smiths' fires they will serve, is based on the assumption that the tuyeres do not exceed 1 inch diameter and that the pressure is conveyed in mains suitable for the volume of air to be transmitted. For heavy fires, with tuyeres exceeding 1 inch diameter, the dimensions of the fan must be increased in proportion with the area of the tuyeres.

PRICES OF BLAST FANS, Fig. 3153.

Diameter of disc .. inches	9	12	16	20	25	30	40	50
„ discharge ..	4½	6	8	10	12½	15	22	25
„ pulley ..	2½	3	3½	4	5	6	9	12
Width of pulley ..	2½	3	3½	4	4½	5	7	8
Revolutions per minute ..	4500	4000	3500	2500	2000	1600	1200	1000
Delivers cubic feet of air per minute ..	1000	2000	4000	7000	9000	12000	19000	29000
Cupolas melting tons per hour	1½	1½	2½	3½	5	10	20
Smiths' hearths served ..	6	7	10	14	22	30	70	160
Price of fan ..	£4	£5 10	£9	£11	£15 10	£20	£35	£54

The cost of packing for shipment and delivery f.o.b. is 5 per cent.

EXHAUST FANS closely resemble blast fans in external appearance but the discs &c. are arranged to exhaust or draw off, so that the effect is precisely the reverse of that last described.

These fans are used to exhaust cold or hot air or gases from tunnels, the fumes from chemical and other works, and are indispensable for drawing out the small particles of dust, and impalpable matter which are generated in many industries such as in flour, woollen, flax and cotton mills, grinding rooms, &c.

PRICES OF EXHAUST FANS.

Diameter of disc .. inches	9	12	16	20	25	30	40	50
„ discharge .. „	4½	6	8	10	12½	15	22	25
„ pulley .. „	2½	3	3½	4	5	6	9	10
Width of pulley .. „	2½	3	3½	4	4½	5	7	8
Revolutions per minute ..	4500	4000	3500	2500	2000	1600	1200	1000
Exhaust cubic feet of air per minute ..	1000	2000	4000	7000	9000	12000	19000	29000
Price of fan ..	£5 5	£6 15	£10 10	£14	£19	£23 10	£42	£68

The cost of packing for shipment and delivery f.o.b. is 5 per cent

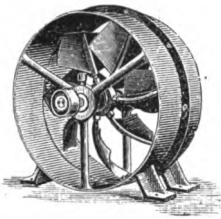

Fig. 3154.

AIR PROPELLORS, Fig. 3154, are also used for ventilating mills, factories, breweries, hospitals, laundries, restaurants, theatres, public buildings, &c. The fans are so arranged that the air is drawn away from the sides of the tube towards the centre and in this way the friction of the moving air is greatly reduced and the driving power required minimised; they are found to work most economically when registering a water gauge of 1½ to 2 inches and in this respect are an improvement on most other fans. They are constructed with a view to lightness and strength and to work with equal efficiency whether bolted to a base, roof, ceiling, or wall, or fixed in any desired position or at any angle. The propeller can be coupled direct to machines where a moderate suction is required. The wings of the propeller can at any time be renewed at a trifling cost and are easily replaced.

Some of the advantages claimed for the air propeller are:—

- It will work against pressure.
- It is unequalled for economy and efficiency.
- It gives large volume at low pressure.

The speeds given are usually adopted but they may be increased if desired.

PRICES OF AIR PROPELLORS, Fig. 3154.

Diameter	12	18	27	36	45	54
Speed	1000 to 1600	700 to 1150	450 to 800	400 to 650	350 to 600	300 to 500
Quantity cubic feet ..	3000	5000	11000	18000	33000	50000
Horse power	0.25	0.50	1.25	2.00	2.50	4.00
Diam. of pulleys ins.	3	4½	6	9	12	15
Price	£5	£7	£12	£17	£25	£36

The cost of packing for shipment and delivery f.o.b. is 5 per cent.

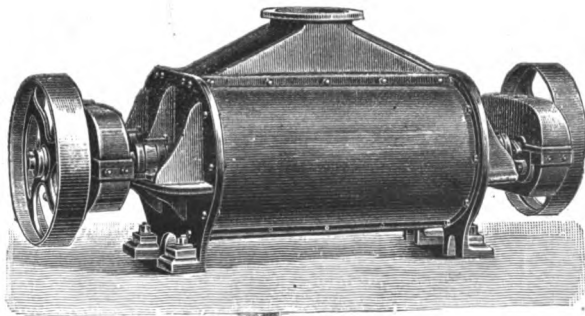

Fig. 3155.

ROOT'S BLOWERS OR EXHAUSTERS, illustrated by Fig. 3155, work at a much lower speed than blast fans and maintain a positive pressure, the force of which can be graduated to suit the widely varying conditions which these machines fulfil, such as supplying the blast for cupolas, smiths' hearths, ventilating mines and for many other purposes. They are also used for exhausting foul air, dust, &c., from factories or from special machines, gasses from chemical works, &c.

Being constructed entirely of metal they are unaffected by heat, cold or moisture, and the proportions, bearing surfaces, &c., are ample in all cases. The outer cover encloses two revolving arms which are accurately balanced; this ensures steady running, and they are so arranged that all the air which enters is forced out at each revolution, without waste of driving power.

Blowers which are not driven direct by an engine are fitted with a pulley and gear at each end

It is desirable that the discharge outlet should be at the bottom and is always in that position unless otherwise ordered.

The volume of blast at each revolution will be found in the subjoined tables, from which it will be seen that, for cupolas, an allowance of 30,000 cubic feet of air is provided for each ton of iron melted per hour.

The revolutions per minute are the maximum the blowers should make.

For smiths' hearths an escape valve should be used, the cost of which will be found in the subjoined list of prices. The duty is calculated on hearths of usual size and the necessary increase in power should be provided for the proportion (if any) of large hearths required.

The power required to drive the blowers is given in I.H.P., and for a pressure of blast equal to $\frac{1}{2}$ -lb. per square inch.

PRICES OF ROOTS BLOWERS, Fig. 3155.

Diameter, discharge outlet .. in.	6	8	10	12	14	16	20
Revolutions per minute	400	350	350	325	310	275	260
Volume blast per revolution, cub. ft.	1 $\frac{1}{2}$	3	5	8	13	22	37
Tons melted per hour	1	2	3 $\frac{1}{2}$	5	8	12	20
Smith's fires served	8	14	23	35	53	80	130
Power required, I.H.P.	2	4	6 $\frac{1}{2}$	10	15	23	36
Price, belt driven blower	£31	£42	£55	£69	£96	£138	£190
„ blower with engine	£63	£81	£115	£161	£207	£287	£362
„ escape valve	£1 15	£2	£2 12	£2 15	£3 10	£3 15	£4 5
Approximate weight blower .. cwt.	6	12	17	24	41	57	97
„ „ „ with engine	9	20	25	37	60	78	125

The cost of packing for shipment and delivery f.o.b. is 5 per cent.

ROOT'S BLOWERS FOR SMITHS, metal workers, chemists, &c., are similar in construction to those last referred to and can be used with advantage where driving power is available.

The price of a blower for one ordinary smith's hearth is	£7	0	0
Ditto ditto large ditto	£9	0	0
Ditto ditto two large or three small hearths is	£15	0	0

HAND POWER ROOT'S BLOWERS as above described, but worked by manual power are made in two sizes, which give a continuous blast, equal, respectively, to that given by 30 to 36 inch bellows.

The price of the smaller size is	£7	0	0
Ditto larger do.	£9	0	0

The cost of packing for shipment and delivery f.o.b. is 6 per cent.

PORTABLE HEARTH WITH ROOT'S BLOWERS, as above. The blower is fixed to the legs which support the hearth and is driven by a pitch chain. This is worked by a rotary motion so that the strength of the blast is under complete control and the coal can be charred in less than half the time usually required; the metal also is evenly heated with a minimum consumption of coal.

The price of the blower with hearth 2 ft. 6 in. by 1 ft. 9 in. is ..	£11	0	0
Ditto ditto 3 ft. 4 in. by 2 ft. 2 in. is ..	£13	15	0

The cost of packing for shipment and delivery f.o.b. is 6 per cent.

SMITHS' HEARTHES of the type indicated in Fig. 3156 are easily removed and for other reasons are much to be preferred to the brick-built hearths which, until recently have been generally used; they occupy less space, and being built throughout of iron, are not liable to deterioration. Each hearth is supplied with water bosh and tue iron, poker, rake and shovel; for shipment these hearths are built in sections, and the packages are thus reduced to a convenient size for transport.

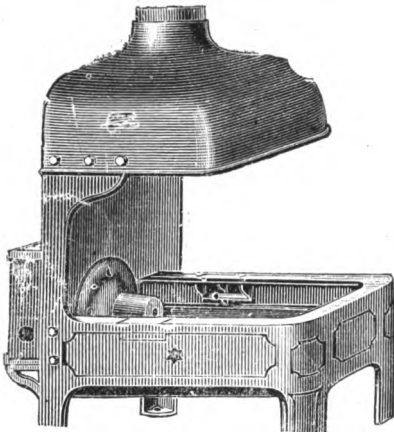

Fig. 3156.

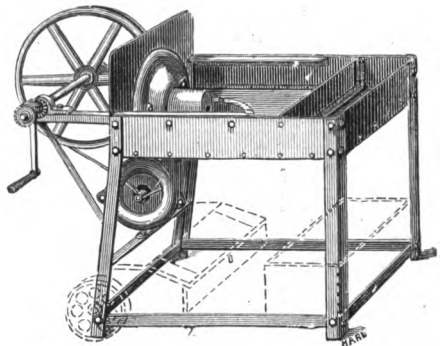

Fig. 3157.

PRICES OF SMITHS' HEARTHES, Fig. 3156.

Size of hearth	3 ft. by 3 ft.	3½ ft. by 3½ ft.	4 ft. by 4 ft.
Height with hood	6 ft.	6 ft.	6 ft.
Price	£11 0 0	£13 0 0	£15 0 0

The cost of packing for shipment and delivery f.o.b. is 5 per cent.

PORTABLE FAN FORGES as illustrated, Figs. 3157 and 3158 are made of wrought iron, and are provided with a powerful rotary fan, easily worked by hand or foot lever; the working parts are as few as possible, and the construction throughout renders them compact, simple, and durable.

PRICES OF SQUARE PORTABLE FAN FORGES, Fig. 3157.

Size of hearth	2ft 2in. by 1ft. 10in.	2 ft. 6 in. by 2 ft.	2ft. 10in. by 2ft. 6in.
Height	2ft. 6in.	2 ft. 6 in.	2ft. 6in.
Price	£5 10 0	£6 1 0	£7 0 0
Extra for hood	25/-	27/6	30/-
„ wheels and handles	12/6	15/-	17/6

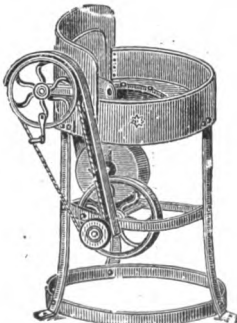

Fig. 3158

PRICES OF CIRCULAR PORTABLE FAN FORGES, Fig. 3158.

Diameter of hearth	20 in.	24 in.
Height	30 in.	32 in.
Price	£3 5 0	£3 19 0
Extra for fire screen	8/6	10/6
Do. water cistern	4/6	5/6
Do. tool chest	5/-	6/-

The cost of packing for shipment and delivery f.o.b. is 10 per cent.

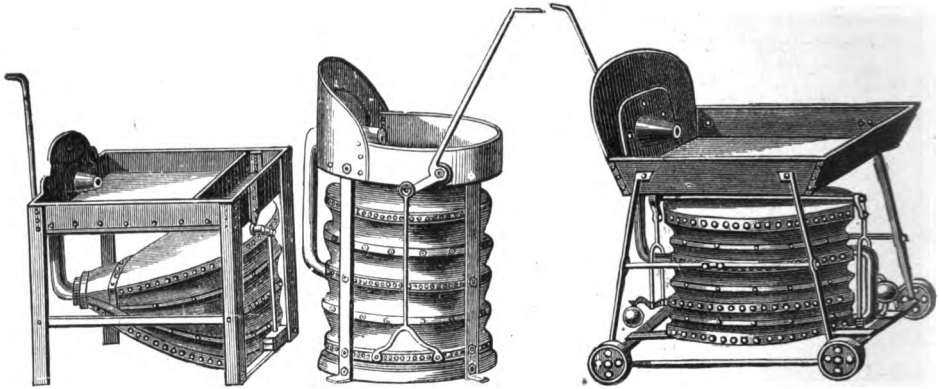

Fig. 3159.

Fig. 3160.

Fig. 3161.

THE PORTABLE FORGES above illustrated are the patterns found most generally useful; Fig. 3159 is especially suitable for shipment, being strong and light, and easily packed into small compass; Fig. 3160 is fitted with double blast bellows ensuring great and rapid heat, and Fig. 3161 represents the single blast rivet forge universally used. Forges to fulfil the same or similar conditions as the above, vary so much in design and construction that it is impossible to enumerate them all, but prices of such variations as may be desired from the types herein referred to may be obtained upon application, and it will suffice to say that all the forges are made, as far as possible, in wrought iron, and embody recent improvements.

PRICES OF WROUGHT IRON PORTABLE FORGES, Fig. 3159.

Size of hearth	29 in. by 24 in.	33 in. by 27 in.	34 in. by 30 in.
Height	2 ft. 10 in.	2 ft. 10 in.	3 ft.
Size of bellows	24 in.	26 in.	28 in.
Price	£4 0 6	£5 4 6	£6 10 0
Extra, if mounted on wheels ..	25/-	27/6	30/-
Do. fitted with vice ..	17/6	20/-	25/-

PRICES OF DOUBLE BLAST PORTABLE FORGES, Fig. 3160.

Diameter of bellows ins.	18	20	22	24	26
Price	£8	£9	£10 6	£11 12	£14 10
Extra, if mounted on wheels as shewn ..	20/-	22/-	24/-	26/-	30/-

PRICES OF SINGLE BLAST RIVET FORGES, Fig. 3161.

Diam. of bellows in.	16	18	20	22	24
Price	£2 8	£2 10	£2 15	£3 5	£3 15

PRICES OF DOUBLE BLAST CIRCULAR BELLOWS, Fig. 3162.

Diam. of bellows in.	18	20	22	24	26
Price	£5 15	£6 12	£7 14	£8 16	£9 18
Weights	4/6	4/6	5/6	5/6	6/6

Diam. of bellows in.	28	30	32	34	36
Price	£11 10	£13 8	£15	£17 10	£20
Weights	6/6	6/6	10/-	10/-	10/-

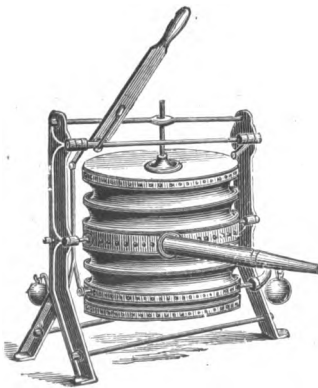

Fig 3162.

PRICES OF SINGLE BLAST CIRCULAR BELLOWS.

Diam. of bellows in.	16	18	20	22	24	26	28	30
Price	£3 14	£4	£4 10	£5 5	£6	£7	£8 8	£100

The cost of packing for shipment and delivery f.o.b. is 5 per cent.

SMITHS' BELLOWS WITH REVERSIBLE PIPE are specially adapted for exportation because, by reversing or inserting the pipe in the bellows, the shipping measurement is reduced by one half: they are so constructed internally that the blast is considerably greater, and they are not so liable to damage as those of the ordinary kind.

PRICES OF SMITHS' BELLOWS WITH REVERSIBLE PIPE.

Length ins.	16	18	20	22	24	26	28	30	32
Price	32/-	38/-	46/-	54/-	64/-	75/-	84/-	100/-	115/-

The price of ordinary long shape Smiths' Bellows is 2½ per cent., and of London Pattern Smiths' Bellows 5 per cent. less than the prices above given.

The cost of packing for shipment and delivery f.o.b. is 5 per cent.

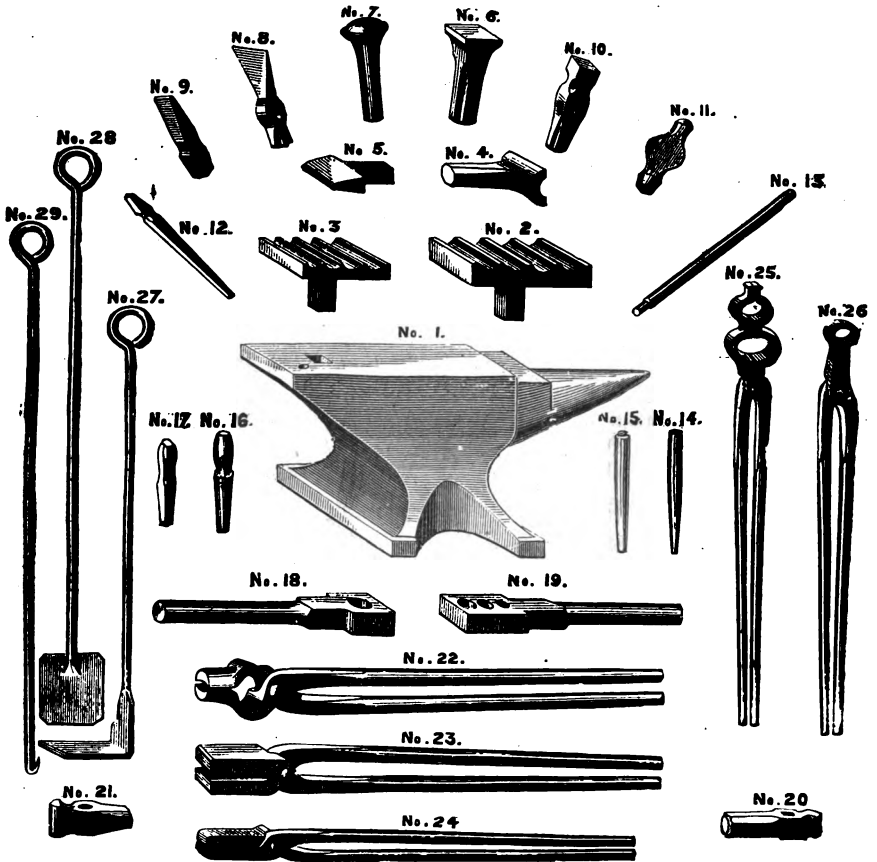

Fig. 3163.

SMITHS' TOOLS.—Fig. 3163 illustrates a set of these as found most generally useful, and below they are enumerated in detail, viz. :—

- No. 1, anvil, best warranted, steel faced, about 3½ cwt.
 - Nos. 2 and 3, bottom swages, eight sizes, viz. : ½, ¾, 1, 1¼, 1½, 1¾, 2 in.
 - No. 4, top swage, eight sizes, viz. : ½, ¾, 1, 1¼, 1½, 1¾, 2 in.
 - No. 5, bottom or anvil fuller.
 - No. 6, flatter.
 - No. 7, two snap tools, hand and rod.
 - No. 8, two hot sets for rod and anvil.
 - No. 9, cast steel cold set.
 - No. 10, square faced set hammer.
 - No. 11, smith's hand hammer.
 - No. 12, Cast steel flat rod punch, three sizes.
 - No. 13, nut mandrils, four sizes.
 - Nos. 14 and 15, hand punches.
 - No. 16, round rod punch, three sizes
 - No. 17, Square rod punch, three sizes.
 - Nos. 18 and 19, bolt tools.
 - No. 20, sledge hammer, 14 lbs. ; flogging hammer, 7 lbs.
 - No. 21, top fuller.
 - No. 22, round mouthed tongs, four pairs assorted.
 - No. 23, open " " " "
 - No. 24, close " " " "
 - No. 25, smiths' pliers.
 - No. 26, bolt tongs, two sizes.
 - Nos. 27, 28 and 29, smiths' firing tools.
- The price of the above set of Smiths' Tools is £19 10 0.
 The cost of packing for shipment and delivery f.o.b. is 3 per cent.



Fig. 3164.

Anvils, best warranted, London pattern, Fig. 3164, made from best selected scrap and well steels, with single or double beak, 28/- per cwt. A useful size for ordinary smiths' work is about 3½ cwt. Anvil stands (Fig. 3164) in cast iron, 12/- per cwt. Usual weight about 1½ cwt.

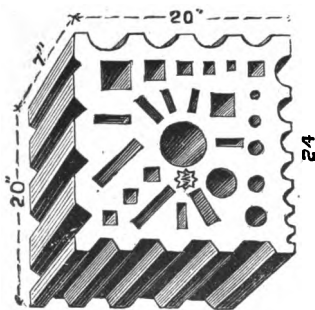

Fig. 3165.

Swage blocks (Fig. 3165) and stands, 12/- per cwt.

The largest size, illustrated, weighs about 6 cwt. complete.

Conical mandrils, cast iron 12 in. to 24 in., 36/- each.

Do. do. do. 3 in. to 12 in., 12/- each.

Vice benches on wrought iron tripod stand, Fig. 3166, with best warranted solid box vices are very handy for ordinary purposes.



Fig. 3166.

PRICES OF VICE BENCHES, Fig. 3166.

Width of jaws ..	4 in.	5 in.	5½ in.	6 in.
Price .. each	£2 10	£3 10	£5	£6 5



Fig. 3167.

Vice benches on wrought iron square stands, Fig. 3167, with best solid box vices, mounted on four wheels, with or without tool chests.

PRICES OF VICE BENCHES, Fig. 3167.

Width of jaws in.	3½	4	4½	5	5½	6
Price, without tool chest ..	£3	£3 5	£3 15	£4 5	£6	£7 10
Do with do. ..	£3 10	£3 15	£4 5	£4 15	£6 15	£8 15

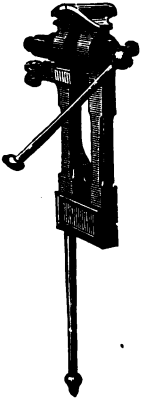

Fig. 3168.

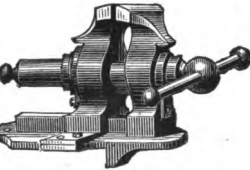

Fig. 3169.

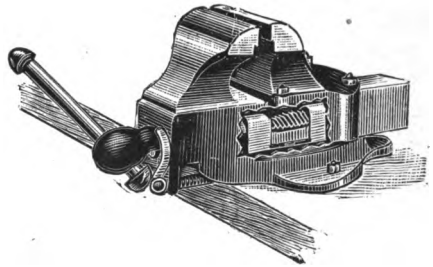

Fig. 3170.

VICES, as most generally used are illustrated by Fig. 3168, and are made of wrought iron throughout, finished bright, or left black as may be preferred.

The price of best bright staple vices is 33/- per cwt.

If left black 30/- per cwt.

The weight of an ordinary smiths' vice with 6 in. jaws is about 100 lbs.

PARALLEL BENCH VICES, Figs. 3169 and 3170 are made entirely of wrought iron ; Fig. 3169 is the ordinary type and the prices are as follows:—

Width of jaw, Fig. 3166 .. in.	3	4	4½	5	6	7	8
Price, with wrought iron jaws.. each	27/-	32/-	39/6	47/-	62/-	80/-	96/-
Extra for swivel in socket for taper grip	12/-	12/-	13/-	13/-	15/-

If fitted with steel jaws, add 5 per cent.

The parallel vice, illustrated by Fig. 3170, combines all the advantages of the continuous screw vice with the quickness and economy of the sudden-grip vice, giving at the same time increased gripping power with less wear and tear.

PRICES OF PATENT PARALLEL VICE, Fig. 3170.

Width of jaw in.	3½	3¾	4½	5½	6½	7	8½
Opening in.	4	4½	5	6½	8½	9½	12
Price each	28/-	34/-	40/-	46/-	58/-	80/-	150/-

Packing for shipment and delivery f.o.b. costs 5 per cent.

Nottingham:

PRINTED BY R. B. EARP & SONS, LTD., GOLDSMITH STREET.

